

CITY OF ANN ARBOR
INVITATION TO BID



Hoover, Greene, & Hill Improvement Project

ITB No. 4563

Due Date: February 22, 2019 2:00 p.m. (Local Time)

Engineering
Public Services Area

Issued By:

City of Ann Arbor
Procurement Unit
301 E. Huron Street
Ann Arbor, MI 48104

TABLE OF CONTENTS

TABLE OF CONTENTS.....	TC-1
NOTICE OF PRE-BID CONFERENCE.....	NP-1
INSTRUCTIONS TO BIDDERS.....	IB-1 to 6
INVITATION TO BID.....	ITB-1 to 3
BID FORMS.....	BF-1 to 9
CONTRACT.....	C-1 to 4
BOND FORMS.....	B-1 to 2
GENERAL CONDITIONS.....	GC-1 to 16
STANDARD SPECIFICATIONS.....	SS-17
DETAILED SPECIFICATION.....	DS-1 to 137
Certified Payroll Compliance and Reporting.....	DS-1 - 2
General Conditions Max. \$ _____	DS-3 - 5
Audio-Visual Recording.....	DS-6 - 9
Material and Supplies Certifications	DS-10
Progress Schedule.....	DS-11 - 13
Utility Clause	DS-14 - 15
Railroad Requirements	DS-16 - 17
Vacuum Type Cleaning Equipment	DS-18
Maintaining Traffic and Construction Sequencing	DS-19 - 53
Temporary Pedestrian Barrier with Fence	DS-54 - 55
Temporary Pedestrian Type II Barricade.....	DS-56 - 57
Temporary Pedestrian Type II Channelizer	DS-58 - 59
Temporary Pedestrian Path.....	DS-60 - 61
Temporary Pedestrian Ramp.....	DS-62 - 64
Permanent Pavement Markings.....	DS-65 - 66
Minor Traffic Devices, Max \$ _____	DS-67 - 68
Parking Meters	DS-69 - 70
Soil Erosion Control Inlet Filter.....	DS-71
Sewer, Any Size or Depth, Rem; Dr. Structure, Any Size or Depth, Rem.....	DS-72
Removing Pavement and Concrete Items	DS-73 - 74
Machine Grading, Modified.....	DS-75 - 81
Subgrade Undercutting	DS-82
Structure Covers.....	DS-83 - 84
Subgrade Underdrain.....	DS-85 - 86
Subbase and Aggregate Base	DS-87 - 88
Maintenance Gravel, 21AA Modified	DS-89 - 90
Flowable Fill	DS-91 - 92
Concrete Placement and Protection.....	DS-93 - 94
Concrete Curb and Driveway Openings	DS-95 - 96
Concrete Sidewalk, ADA Ramps, and Driveway Approaches	DS-97 - 99
Detectable Warning Surface	DS-100 - 101
Removal and Reinstallation of Concrete or Clay Brick Pavers	DS-102 - 103

HMA Pavement Repair.....	DS-104
Acceptance of HMA Mixtures	DS-105 - 113
HMA Paving	DS-114 - 117
No Parking Signs.....	DS-118 - 119
Protecting and Preserving Irrigation Systems.....	DS-120 - 121
Project Clean-Up and Restoration, Special.....	DS-122 - 123
Turf Establishment	DS-124 - 126
Storm Control Structure.....	DS-127
Pedestrian Light Remove and Re-install	DS-128
Electrical and Communication Handholes.....	DS-129 - 131
Water Main and Appurtenances.....	DS-132 - 155
Temporary Water Main Line Stop	DS-156 - 161
Water Main and Appurtenances, Remove or Abandon.....	DS-162 - 163

APPENDIX.....	APDX-1
---------------	--------

Geotechnical Information

- Tetra Tech boring information 05/18
- TTL Core Log 12/18

ATTACHMENTS

- City of Ann Arbor Prevailing Wage Declaration Form*
- City of Ann Arbor Living Wage Forms*
- City of Ann Arbor Vendor Conflict of Interest Disclosure Form*
- City of Ann Arbor Non-Discrimination Ordinance Notice and Declaration Form*

NOTICE OF PRE-BID CONFERENCE

A pre-bid conference for this project will be held on **Friday, February 8, 2019 at 2:00 p.m.** in the **6th Floor Conference Room** of the Guy C. Larcom Municipal Building (formerly known as City Hall), 301 E. Huron Street, Ann Arbor, Michigan 48104.

Attendance at this conference is highly recommended. Administrative and technical questions regarding this project will be answered at this time. The pre-bid conference is for information only. Any answers furnished will not be official until verified in writing by the Financial Service Area, Procurement Unit. Answers that change or substantially clarify the bid will be affirmed in an addendum.

INSTRUCTIONS TO BIDDERS

General

Work to be done under this Contract is generally described through the detailed specifications and must be completed fully in accordance with the contract documents. All work to be done under this Contract is located in or near the City of Ann Arbor.

Any Bid which does not conform fully to these instructions may be rejected.

Preparation of Bids

Bids should be prepared providing a straight-forward, concise description of the Bidder's ability to meet the requirements of the ITB. Bids shall be written in ink or typewritten. No erasures are permitted. Mistakes may be crossed out and corrected and must be initialed and dated in ink by the person signing the Bid.

Bids must be submitted on the "Bid Forms" provided with each blank properly filled in. If forms are not fully completed it may disqualify the bid. No alternative bid will be considered unless alternative bids are specifically requested. If alternatives are requested, any deviation from the specification must be fully described, in detail on the "Alternate" section of Bid form.

Each person signing the Bid certifies that he/she is the person in the Bidder's firm/organization responsible for the decision as to the fees being offered in the Bid and has not and will not participated in any action contrary to the terms of this provision.

Questions or Clarifications / Designated City Contacts

All questions regarding this ITB shall be submitted via email. Emailed questions and inquires will be accepted from any and all prospective Bidders in accordance with the terms and conditions of the ITB.

All questions shall be due on or before 2:00 p.m. (Local Time) Wednesday, February 13, 2019 and should be addressed as follows:

Specification/Scope of Work questions emailed to **cwall@a2gov.org**
Bid Process and Compliance questions emailed to **cspencer@a2gov.org**

Any error, omissions or discrepancies in the specification discovered by a prospective contractor and/or service provider shall be brought to the attention of **Christopher Wall, P.E., Project Manager** at **cwall@a2gov.org** after discovery as possible. Further, the contractor and/or service provide shall not be allowed to take advantage of errors, omissions or discrepancies in the specifications.

Addenda

If it becomes necessary to revise any part of the ITB, notice of the Addendum will be posted to Michigan Inter-governmental Trade Network (MITN) www.mitn.info and/or City of Ann Arbor web site www.A2gov.org for all parties to download.

Each Bidder must in its Bid, to avoid any miscommunications, acknowledge all addenda which it has received, but the failure of a Bidder to receive, or acknowledge receipt of; any addenda shall not relieve the Bidder of the responsibility for complying with the terms thereof.

The City will not be bound by oral responses to inquiries or written responses other than written addenda.

Bid Submission

All Bids are due and must be delivered to the City of Ann Arbor Procurement Unit on or before **2:00 p.m. local time, Friday, February 22, 2019**. Bids submitted late or via oral, telephonic, telegraphic, electronic mail or facsimile **will not** be considered or accepted.

Each Bidder must submit one (1) original Bid and **one (1)** Bid copy in a sealed envelope clearly marked: **ITB No. 4563 Hoover, Greene, & Hill Improvement Project**.

Bids must be addressed and delivered to:

City of Ann Arbor
Procurement Unit,
c/o Customer Services, 1st Floor
301 East Huron Street
Ann Arbor, MI 48107

All Bids received on or before the Due Date will be publicly opened and recorded immediately. No immediate decisions are rendered.

The following forms provided within this ITB Document must be included in submitted bids.

- **City of Ann Arbor Prevailing Wage Declaration of Compliance**
- **City of Ann Arbor Living Wage Ordinance Declaration of Compliance**
- **Vendor Conflict of Interest Disclosure Form**
- **City of Ann Arbor Non-Discrimination Ordinance Declaration of Compliance**

Bids that fail to provide these completed forms listed above upon bid opening will be rejected as non-responsive and will not be considered for award.

Hand delivered bids will be date/time stamped/signed by the Procurement Unit at the address above in order to be considered. Normal business hours are 9:00 a.m. to 3:00 p.m. Monday through Friday, excluding Holidays. The City will not be liable to any Bidder for any unforeseen circumstances, delivery or postal delays. Postmarking to the Due Date will not substitute for receipt of the Bid. Each Bidder is responsible for submission of their Bid.

Additional time for submission of bids past the stated due date and time will not be granted to a single Bidder; however, additional time may be granted to all Bidders when the City determines in its sole discretion that circumstances warrant it.

Award

The City intends to award a Contract(s) to the lowest responsible Bidder(s). On multi-divisional contracts, separate divisions may be awarded to separate Bidders. The City may also utilize alternatives offered in the Bid Forms, if any, to determine the lowest responsible Bidder on each division, and award multiple divisions to a single Bidder, so that the lowest total cost is achieved for the City. For unit price bids, the Contract will be awarded based upon the unit prices and the lump sum prices stated by the bidder for the work items specified in the bid documents, with consideration given to any alternates selected by the City. If the City determines that the unit price

for any item is materially different for the work item bid than either other bidders or the general market, the City, in its sole discretion, in addition to any other right it may have, may reject the bid as not responsible or non-conforming.

The acceptability of major subcontractors will be considered in determining if a Bidder is responsible. In comparing Bids, the City will give consideration to alternate Bids for items listed in the bid forms. All key staff and subcontractors are subject to the approval by the City.

Official Documents

The City of Ann Arbor officially distributes bid documents from the Procurement Unit or through the Michigan Intergovernmental Trade Network (MITN). Copies of the bid documents obtained from any other source are not Official copies. Addenda and other bid information will only be posted to these official distribution sites. If you obtained City of Ann Arbor Bid documents from other sources, it is recommended that you register on www.MITN.info and obtain an official Bid. Bidders do not need to be shown on the plan holders list provided by MITN to be considered an official plan holder.

Bid Security

Each bid must be accompanied by a certified check or Bid Bond by a surety licensed and authorized to do business within the State of Michigan, in the amount of 5% of the total of the bid price.

Withdrawal of Bids

After the time of opening, no Bid may be withdrawn for the period of sixty (60) days.

Contract Time

Time is of the essence in the performance of the work under this Contract. The available time for work under this Contract is indicated on page C-1, Article III of the Contract. If these time requirements can not be met, the Bidder must stipulate on Bid Form Section 3 - Time Alternate its schedule for performance of the work. Consideration will be given to time in evaluating bids.

Liquidated Damages

A liquidated damages clause, as given on page C-2, Article III of the Contract, provides that the Contractor shall pay the City as liquidated damages, and not as a penalty, a sum certain per day for each and every day that the Contractor may be in default of completion of the specified work, within the time(s) stated in the Contract, or written extensions.

Liquidated damages clauses, as given in the General Conditions, provide further that the City shall be entitled to impose and recover liquidated damages for breach of the obligations under Chapter 112 of the City Code.

The liquidated damages are for the non-quantifiable aspects of any of the previously identified events and do not cover actual damages that can be shown or quantified nor are they intended to preclude recovery of actual damages in addition to the recovery of liquidated damages.

Human Rights Information

All contractors proposing to do business with the City shall satisfy the contract compliance administrative policy adopted by the City Administrator in accordance with the Section 9:158 of the Ann Arbor City Code. Breach of the obligation not to discriminate as outlined in Section 5, beginning at page GC-2 shall be a material breach of the contract. Contractors are required to

post a copy of Ann Arbor's Non-Discrimination Ordinance attached at all work locations where its employees provide services under a contract with the City.

Wage Requirements

Section 4, beginning at page GC-1, outlines the requirements for payment of prevailing wages and for payment of a "living wage" to employees providing service to the City under this contract. The successful bidder and its subcontractors must comply with all applicable requirements and provide proof of compliance.

Pursuant to Resolution R-16-469 all public improvement contractors are subject to prevailing wage and will be required to provide to the City payroll records sufficient to demonstrate compliance with the prevailing wage requirements. Use of the Prevailing Wage Form provided in the Appendix section or a City-approved equivalent will be required along with wage rate interviews.

For laborers whose wage level are subject to federal, state and/or local prevailing wage law the appropriate Davis-Bacon wage rate classification is identified based upon the work including within this contract. **The wage determination(s) current on the date 10 days before bids are due shall apply to this contract.** The U.S. Department of Labor (DOL) has provided explanations to assist with classification in the following resource link: www.wdol.gov.

For the purposes of this ITB the Construction Type of Heavy and Highway will apply.

Conflict Of Interest Disclosure

The City of Ann Arbor Purchasing Policy requires that prospective Vendors complete a Conflict of Interest Disclosure form. A contract may not be awarded to the selected Vendor unless and until the Procurement Unit and the City Administrator have reviewed the Disclosure form and determined that no conflict exists under applicable federal, state, or local law or administrative regulation. Not every relationship or situation disclosed on the Disclosure Form may be a disqualifying conflict. Depending on applicable law and regulations, some contracts may awarded on the recommendation of the City Administrator after full disclosure, where such action is allowed by law, if demonstrated competitive pricing exists and/or it is determined the award is in the best interest of the City. A copy of the Vendor Conflict of Interest Disclosure Form is attached.

Major Subcontractors

The Bidder shall identify on Bid Form Section 4 each major subcontractor it expects to engage for this Contract if the work to be subcontracted is 15% or more of the bid sum or over \$50,000, whichever is less. The Bidder also shall identify the work to be subcontracted to each major subcontractor. The Bidder shall not change or replace a subcontractor without approval by the City.

Debarment

Submission of a Bid in response to this ITB is certification that the Bidder is not currently debarred, suspended, proposed for debarment, and declared ineligible or voluntarily excluded from participation in this transaction by any State or Federal departments or agency. Submission is also agreement that the City will be notified of any changes in this status.

Disclosures

After bids are opened, all information in a submitter's bid is subjected to disclosure under the provisions of Michigan Public Act No. 442 of 1976, as amended (MCL 15.231 et seq.) known as

the "Freedom of Information Act." The Freedom of Information Act also provides for the complete disclosure of contracts and attachments thereto except where specifically exempted.

Bid Protest

All Bid protests must be in writing and filed with the Purchasing Agent within five (5) business days of the award action. The bidder must clearly state the reasons for the protest. If a bidder contacts a City Service Area/Unit and indicates a desire to protest an award, the Service Area/Unit shall refer the bidder to the Purchasing Agent. The Purchasing Agent will provide the bidder with the appropriate instructions for filing the protest. The protest shall be reviewed by the City Administrator or designee whose decision shall be final.

Any inquiries or requests regarding this procurement should be only submitted in writing to the Designated City Contacts provided herein. Attempts by any prospective bidder to initiate contact with anyone other than the Designated City Contacts provided herein that the bidder believes can influence the procurement decision, e.g., Elected Officials, City Administrator, Selection Committee Members, Appointed Committee Members, etc., may lead to immediate elimination from further consideration.

Cost Liability

The City of Ann Arbor assumes no responsibility or liability for costs incurred by the Bidder prior to the execution of a contract with the City. By submitting a bid, a bidder agrees to bear all costs incurred or related to the preparation, submission and selection process for the bid.

Reservation of Rights

The City of Ann Arbor reserves the right to accept any bid or alternative bid proposed in whole or in part, to reject any or all bids or alternatives bids in whole or in part and to waive irregularity and/or informalities in any bid and to make the award in any manner deemed in the best interest of the City.

Idlefree Ordinance

The City of Ann Arbor adopted an idling reduction Ordinance that goes into effect July 1, 2017. The full text of the ordinance (including exemptions) can be found at: www.a2gov.org/idlefree.

Under the ordinance, No Operator of a Commercial Vehicle shall cause or permit the Commercial Vehicle to Idle:

- (a) For any period of time while the Commercial Vehicle is unoccupied; or
- (b) For more than 5 minutes in any 60-minute period while the Commercial Vehicle is occupied.

In addition, generators and other internal combustion engines are covered

(1) Excluding Motor Vehicle engines, no internal combustion engine shall be operated except when it is providing power or electrical energy to equipment or a tool that is actively in use.

Environmental Commitment

The City of Ann Arbor recognizes its responsibility to minimize negative impacts on human health and the environment while supporting a vibrant community and economy. The City further recognizes that the products and services the City buys have inherent environmental and economic impacts and that the City should make procurement decisions that embody, promote, and encourage the City's commitment to the environment.

The City encourages potential vendors to bring forward emerging and progressive products and services that are best suited to the City's environmental principles.

INVITATION TO BID

City of Ann Arbor
Guy C. Larcom Municipal Building
Ann Arbor, Michigan 48107

Ladies and Gentlemen:

The undersigned, as Bidder, declares that this Bid is made in good faith, without fraud or collusion with any person or persons bidding on the same Contract; that this Bidder has carefully read and examined the bid documents, including City Nondiscrimination requirements and Declaration of Compliance Form, Living Wage requirements and Declaration of Compliance Form, Prevailing Wage requirements and Declaration of Compliance Form, Vendor Conflict of Interest Form, Notice of Pre-Bid Conference, Instructions to Bidders, Bid, Bid Forms, Contract, Bond Forms, General Conditions, Standard Specifications, Detailed Specifications, all Addenda, and the Plans (if applicable) and understands them. The Bidder declares that it conducted a full investigation at the site and of the work proposed and is fully informed as to the nature of the work and the conditions relating to the work's performance. The Bidder also declares that it has extensive experience in successfully completing projects similar to this one.

The Bidder acknowledges that it has not received or relied upon any representations or warrants of any nature whatsoever from the City of Ann Arbor, its agents or employees, and that this Bid is based solely upon the Bidder's own independent business judgment.

The undersigned proposes to perform all work shown on the plans or described in the bid documents, including any addenda issued, and to furnish all necessary machinery, tools, apparatus, and other means of construction to do all the work, furnish all the materials, and complete the work in strict accordance with all terms of the Contract of which this Bid is one part.

In accordance with these bid documents, and Addenda numbered _____, the undersigned, as Bidder, proposes to perform at the sites in and/or around Ann Arbor, Michigan, all the work included herein for the amounts set forth in the Bid Forms.

The Bidder declares that it has become fully familiar with the liquidated damage clauses for completion times and for compliance with City Code Chapter 112, understands and agrees that the liquidated damages are for the non-quantifiable aspects of non-compliance and do not cover actual damages that may be shown and agrees that if awarded the Contract, all liquidated damage clauses form part of the Contract.

The Bidder declares that it has become fully familiar with the provisions of Chapter 14, Section 1:320 (Prevailing wages) and Chapter 23 (Living Wage) of the Code of the City of Ann Arbor and that it understands and agrees to comply, to the extent applicable to employees providing services to the City under this Contract, with the wage and reporting requirements stated in the City Code provisions cited. Bidder certifies that the statements contained in the City Prevailing Wage and Living Wage Declaration of Compliance Forms are true and correct. Bidder further agrees that the cited provisions of Chapter 14 and Chapter 23 form a part of this Contract.

The Bidder declares that it has become familiar with the City Conflict of Interest Disclosure Form and certifies that the statement contained therein is true and correct.

The Bidder encloses a certified check or Bid Bond in the amount of 5% of the total of the Bid Price. The Bidder agrees both to contract for the work and to furnish the necessary Bonds and insurance documentation within 10 days after being notified of the acceptance of the Bid.

If this Bid is accepted by the City and the Bidder fails to contract and furnish the required Bonds and insurance documentation within 10 days after being notified of the acceptance of this Bid, then the Bidder shall be considered to have abandoned the Contract and the certified check or Bid Bond accompanying this Bid shall become due and payable to the City.

If the Bidder enters into the Contract in accordance with this Bid, or if this Bid is rejected, then the accompanying check or Bid Bond shall be returned to the Bidder.

In submitting this Bid, it is understood that the right is reserved by the City to accept any Bid, to reject any or all Bids, to waive irregularities and/or informalities in any Bid, and to make the award in any manner the City believes to be in its best interest.

SIGNED THIS _____ DAY OF _____, 2019.

Bidder's Name

Authorized Signature of Bidder

Official Address

(Print Name of Signer Above)

Telephone Number

Email Address for Award Notice

LEGAL STATUS OF BIDDER

(The Bidder shall fill out the appropriate form and strike out the other three.)

Bidder declares that it is:

* A corporation organized and doing business under the laws of the State of _____, for whom _____, bearing the office title of _____, whose signature is affixed to this Bid, is authorized to execute contracts.

NOTE: If not incorporated in Michigan, please attach the corporation's Certificate of Authority

• A limited liability company doing business under the laws of the State of _____, whom _____ bearing the title of _____ whose signature is affixed to this proposal, is authorized to execute contract on behalf of the LLC.

* A partnership, organized under the laws of the state of _____ and filed in the county of _____, whose members are (list all members and the street and mailing address of each) (attach separate sheet if necessary):

* An individual, whose signature with address, is affixed to this Bid: _____ (initial here)

Authorized Official

_____ **Date** _____, 2019

(Print) Name _____ Title _____

Company: _____

Address: _____

Contact Phone () _____ Fax () _____

Email _____

BID FORM

Section 1 – Schedule of Prices

Company: _____

Project: **Hoover, Greene, & Hill Improvement Project**

City of Ann Arbor File No.: 2018-031

<u>Item</u>	<u>Description</u>	<u>Unit</u>	<u>Quantity</u>	<u>Unit Price</u>	<u>Total Price</u>
130	Protective Fencing	Ft	2,000	_____	_____
140	Exploratory Excavation, (0-10 ft. deep) (Trench Det 1, Modified)	Ea	16	_____	_____
201	Certified Payroll Compliance and Reporting	LSUM	1	_____	_____
202	General Conditions, Max <u>\$370,000.00</u>	LSUM	1	_____	_____
203	Audio-visual Recording	LSUM	1	_____	_____
204	Traffic Regulator Control	LSUM	1	_____	_____
205	Barricade, Type III, High Intensity, Lighted, Furn & Oper	Ea	20	_____	_____
206	Channelizing Device, 42 inch, High Intensity, Furn & Oper	Ea	225	_____	_____
207	Plastic Drum, High Intensity, Furn & Oper	Ea	55	_____	_____
208	Sign, Type B, Temp, Prismatic, Special, Furn & Oper	Sft	500	_____	_____
209	Sign, Type A, Temp, Prismatic, Furn & Oper	Sft	60	_____	_____
210	Sign, Type B, Temp, Prismatic, Furn & Oper	Sft	1,400	_____	_____
211	Lighted Arrow, Type C, Furn & Oper	Ea	4	_____	_____
212	Sign, Portable, Changeable Message, NTFCIP- Compliant, Furn & Oper	Ea	4	_____	_____
213	Remove Special Marking	Sft	300	_____	_____
214	Concrete Barrier, Temp, Furn & Oper	Ft	100	_____	_____
215	Sign Cover	Ea	10	_____	_____
216	Pedestrian Barrier with Fence, Temp	Ft	100	_____	_____
217	Pedestrian Type II Barricade, Temp	Ea	30	_____	_____
218	Pedestrian Type II Channelizer, Temp	Ft	300	_____	_____
219	Pedestrian Path, Temp	Ft	100	_____	_____
220	Pedestrian Ramp, Temp	Ea	6	_____	_____
221	Pavt Mrkg, Sprayable Thermopl, 4 inch, Yellow	Ft	8,000	_____	_____
221	Pavt Mrkg, Sprayable Thermopl, 4 inch, White	Ft	4,200	_____	_____
222	Pavt Mrkg, Thermoplastic, 24 inch Stop Bar	Ft	400	_____	_____
223	Pavt Mrkg, Thermopl, 12 inch Crosswalk	Ft	2,300	_____	_____

Sub-Total This Page \$ _____

BID FORM

Section 1 – Schedule of Prices

Company: _____

Project: **Hoover, Greene, & Hill Improvement Project**

City of Ann Arbor File No.: 2018-031

<u>Item</u>	<u>Description</u>	<u>Unit</u>	<u>Quantity</u>	<u>Unit Price</u>	<u>Total Price</u>
224	Pavt Mrkg, Ovly Cold Plastic, Railroad Sym	Ea	4	_____	_____
224	Pavt Mrkg, Ovly Cold Plastic, Bike Arrow Sym	Ea	11	_____	_____
224	Pavt Mrkg, Ovly Cold Plastic, Bike Sym	Ea	11	_____	_____
224	Pavt Mrkg, Ovly Cold Plastic, Sharrow Sym	Ea	10	_____	_____
224	Pavt Mrkg, Ovly Cold Plastic, Rt Arrow Sym	Ea	7	_____	_____
224	Pavt Mrkg, Ovly Cold Plastic, Lt Arrow Sym	Ea	7	_____	_____
226	Minor Traffic Devices, Max <u>\$180,000.00</u>	LSUM	1	_____	_____
228	Parking Meters, Remove	Ea	7	_____	_____
229	Erosion Control, Inlet Filter	Ea	65	_____	_____
230	Sewer, Any Size or Depth, Rem	Ft	2,500	_____	_____
231	Dr Structure, Any Size or Depth, Rem	Ea	21	_____	_____
233	Curb and Gutter, Any Type or Size, Rem	Ft	4,000	_____	_____
234	Sidewalk and Ramps, Remove	Sft	10,300	_____	_____
235	Driveway Approach, Remove	Sft	2,600	_____	_____
236	Pavement, Remove	Syd	16,400	_____	_____
238	Machine Grading, Modified, Greene	Sta	13.5	_____	_____
238	Machine Grading, Modified, Hill	Sta	5.75	_____	_____
238	Machine Grading, Modified, Hoover	Sta	27	_____	_____
241	Subgrade Undercutting, Type IIB	Cyd	200	_____	_____
242	Structure Covers, Special	Lbs	39,800	_____	_____
243	6 inch, Wrapped Underdrain	Ft	3,500	_____	_____
244	Aggregate Base Course, 21AA, Modified	Ton	6,350	_____	_____
245	Maintenance Gravel, 21AA, Modified	Ton	500	_____	_____
246	Flowable Fill (Backfill)	Cyd	30	_____	_____
250	Curb and Gutter, Conc, Match Existing, Special	Ft	1,550	_____	_____
251	Curb and Gutter, Conc, AA Det SD-R-1, Special	Ft	1,800	_____	_____

Sub-Total This Page \$ _____

BID FORM

Section 1 – Schedule of Prices

Company: _____

Project: **Hoover, Greene, & Hill Improvement Project**

City of Ann Arbor File No.: 2018-031

<u>Item</u>	<u>Description</u>	<u>Unit</u>	<u>Quantity</u>	<u>Unit Price</u>	<u>Total Price</u>
252	Driveway Opening, Conc, Detail M, P-NC	Ft	650	_____	_____
255	Sidewalk, Concrete, 4 inch, Special	Sft	2,850	_____	_____
255	Sidewalk, Concrete, 6 inch, Special	Sft	80	_____	_____
256	Sidewalk Ramp, Concrete, 6 inch, Special	Sft	1,000	_____	_____
257	Sidewalk, Concrete, 8 inch, S2 Special	Sft	5,280	_____	_____
258	Sidewalk Ramp, Concrete, 8 inch, S2 Special	Sft	1,090	_____	_____
259	Drive Approach, Conc, 6 inch, Non-Reinf	Sft	2,000	_____	_____
260	Concrete Drive Approach, 8 inch, Non-Reinf, P-NC	Sft	600	_____	_____
261	Detectable Warning Surface, Modified	Ft	341	_____	_____
263	Sidewalk, Conc or Clay Brick Pavers, Rem and Reinstall	Sft	360	_____	_____
264	Cold Milling HMA Surface, Modified	Syd	1,050	_____	_____
265	Hand Patching, Modified	Ton	50	_____	_____
266	HMA, 3E1	Ton	2,790	_____	_____
267	HMA, 4E1	Ton	1,370	_____	_____
268	HMA, 5E1	Ton	1,860	_____	_____
270	No Parking Sign	Ea	120	_____	_____
272	Irrigation System, Protection and Maintenance	LSUM	1	\$10,000.00	\$10,000.00
274	Project Clean-Up and Restoration, Special - Greene	LSUM	1	_____	_____
274	Project Clean-Up and Restoration, Special - Hill	LSUM	1	_____	_____
274	Project Clean-Up and Restoration, Special - Hoover	LSUM	1	_____	_____
276	Topsoil Surface, 4 inch	Syd	1,200	_____	_____
277	Seeding and Mulching	Syd	1,200	_____	_____
278	Storm Control Structure, R1	Each	1	_____	_____
278	Storm Control Structure, R2	Each	1	_____	_____
278	Storm Control Structure, R3	Each	1	_____	_____
278	Storm Control Structure, R97-51067	Each	1	_____	_____

Sub-Total This Page \$ _____

BID FORM

Section 1 – Schedule of Prices

Company: _____

Project: **Hoover, Greene, & Hill Improvement Project**

City of Ann Arbor File No.: 2018-031

<u>Item</u>	<u>Description</u>	<u>Unit</u>	<u>Quantity</u>	<u>Unit Price</u>	<u>Total Price</u>
281	Pedestrian Light, Remove and Re-Install	Each	2	_____	_____
282	Handhole Assembly, 12 inch x 18 inch	Ea	17	_____	_____
283	Conduit, Directional Bore, 3 inch	Ft	2,815	_____	_____
284	D.I., CI-56, Water Main, w/Poly Wrap, 12 inch, Bored in Steel Casing	Ft	232	_____	_____
285	PC 350, D.I. Water Main, w/Poly Wrap, 12 inch, Tr Det I, Mod	Ft	3,297	_____	_____
285	PC 350, D.I. Water Main, w/Poly Wrap, 4 inch, Tr Det I, Mod	Ft	17	_____	_____
285	PC 350, D.I. Water Main, w/Poly Wrap, 8 inch, Tr Det I, Mod	Ft	105	_____	_____
286	90 deg Bend, 12 inch	Ea	2	_____	_____
286	45 deg Bend, 12 inch	Ea	80	_____	_____
286	22.5 deg Bend, 12 inch	Ea	2	_____	_____
286	11.25 deg Bend, 12 inch	Ea	2	_____	_____
286	90 deg Bend, 4 Inch	Ea	1	_____	_____
287	Reducer, 12 inch x 6 inch	Ea	14	_____	_____
287	Reducer, 8 inch x 6 inch	Ea	8	_____	_____
288	Tee, 12 inch x 12 inch x 12 inch	Ea	12	_____	_____
288	Tee, 12 inch x 12 inch x 10 inch	Ea	1	_____	_____
288	Tee, 12 inch x 12 inch x 4 inch	Ea	1	_____	_____
288	Tee, 12 inch x 12 inch x 6 inch	Ea	1	_____	_____
288	Tee, 12 inch x 12 inch x 8 inch	Ea	8	_____	_____
289	Fire Hydrant Assy, w/Extensions, Complete	Ea	9	_____	_____
290	Gate Valve-in-Box, 12 inch	Ea	6	_____	_____
290	Gate Valve-in-Box, 4 inch	Ea	1	_____	_____
291	Gate Valve-in-Well, 12 inch	Ea	14	_____	_____
292	Tapping Sleeve, 16 inch x 16 inch x 12 inch, Valve and Box	Ea	1	_____	_____
292	Tapping Sleeve, 10 inch x 10 inch x 4 inch, Valve and Box	Ea	1	_____	_____
293	Line Stop, Ductile Iron Pipe, 8 inch	Ea	1	_____	_____
293	Line Stop, Ductile Iron Pipe, 6 inch	Ea	7	_____	_____
294	6 inch Water Main, Abandon	Lft	4,966	_____	_____

Sub-Total This Page \$ _____

BID FORM

Section 1 – Schedule of Prices

Company: _____

Project: **Hoover, Greene, & Hill Improvement Project**

City of Ann Arbor File No.: 2018-031

<u>Item</u>	<u>Description</u>	<u>Unit</u>	<u>Quantity</u>	<u>Unit Price</u>	<u>Total Price</u>
295	Water Main, Abandon w/Flowable Fill	Lft	145	_____	_____
296	Gate Valve-in-Box, Abandon	Ea	13	_____	_____
297	Gate Valve-in-Well, Abandon	Ea	10	_____	_____
298	Fire Hydrant, Rem	Ea	7	_____	_____
299	Tapping Sleeve, Valve and Well, Remove	Ea	1	_____	_____
320	RCP, Sewer, C76, CL-IV, 12 inch, Tr Det I	Ft	12	_____	_____
321	RCP, Sewer, C76, CL-IV, 15 inch, Tr Det I	Ft	40	_____	_____
322	RCP, Sewer, C76, CL- IV, 36 inch, Tr Det I	Ft	754	_____	_____
323	RCP, Sewer, C76, CL- IV, 48 inch, Tr Det I	Ft	491	_____	_____
335	SDR35, PVC Tee	Ea	2	_____	_____
350	SDR 35 PVC Riser	Vft	10	_____	_____
353	SDR 35 PVC Service Lead	Ft	40	_____	_____
360	Type I Manhole (0-10 ft. Deep)	Ea	2	_____	_____
361	Type I Manhole Add'l Depth	Vf	10	_____	_____
362	Type II Manhole (6' Dia.) (0-10 ft. deep)	Ea	8	_____	_____
363	Type II Manhole (6' Dia.) Add'l Depth	Vf	9	_____	_____
367	Single Inlet	Ea	6	_____	_____
460	Excavate & Backfill for Water Service Tap and Lead	Lft	400	_____	_____
564	Reconstruct Structure	Ea	3	_____	_____
566	Adjust Structure Cover	Ea	75	_____	_____
567	Adjust Monument Box or Gate Valve Box	Ea	4	_____	_____
568	Additional Depth Structure-Adjustment/Repair	Vft	20	_____	_____
703	Silt Fence	Ft	1,000	_____	_____

Sub-Total This Page \$ _____

Sub-Total Page BF-1 \$ _____

Sub-Total Page BF-2 \$ _____

Sub-Total Page BF-3 \$ _____

Sub-Total Page BF-4 \$ _____

Grand Total Bid \$ _____

BID FORM

Section 2 – Material, Equipment and Environmental Alternates

The Base Bid proposal price shall include materials and equipment selected from the designated items and manufacturers listed in the bidding documents. This is done to establish uniformity in bidding and to establish standards of quality for the items named.

If the Contractor wishes to quote alternate items for consideration by the City, it may do so under this Section. A complete description of the item and the proposed price differential must be provided. Unless approved at the time of award, substitutions where items are specifically named will be considered only as a negotiated change in Contract Sum.

If an environmental alternative is bid the City strongly encourages bidders to provide recent examples of product testing and previous successful use for the City to properly evaluate the environmental alternative. Testing data from independent accredited organizations are strongly preferred.

<u>Item Number</u>	<u>Description</u>	<u>Add/Deduct Amount</u>
--------------------	--------------------	--------------------------

If the Bidder does not suggest any material or equipment alternate, the Bidder **MUST** complete the following statement:

For the work outlined in this request for bid, the bidder does NOT propose any material or equipment alternate under the Contract.

Signature of Authorized Representative of Bidder _____ Date _____

BID FORM

Section 3 - Time Alternate

If the Bidder takes exception to the time stipulated in Article III of the Contract, Time of Completion, page C-2, it is requested to stipulate below its proposed time for performance of the work. Consideration will be given to time in evaluating bids.

If the Bidder does not suggest any time alternate, the Bidder **MUST** complete the following statement:

For the work outlined in this request for bid, the bidder does NOT propose any time alternate under the Contract.

Signature of Authorized Representative of Bidder _____ Date _____

BID FORM

Section 4 - Major Subcontractors

For purposes of this Contract, a Subcontractor is anyone (other than the Contractor) who performs work (other than or in addition to the furnishing of materials, plans or equipment) at or about the construction site, directly or indirectly for or on behalf of the Contractor (and whether or not in privity of Contract with the Contractor), but shall not include any individual who furnishes merely the individual's own personal labor or services.

Contractor agrees that all subcontracts entered into by the Contractor shall contain similar wage provision to Section 4 of the General Conditions covering subcontractor's employees who perform work on this contract.

For the work outlined in these documents the Bidder expects to engage the following major subcontractors to perform the work identified:

<u>Subcontractor (Name and Address)</u>	<u>Work</u>	<u>Amount</u>
---	-------------	---------------

If the Bidder does not expect to engage any major subcontractor, the Bidder **MUST** complete the following statement:

For the work outlined in this request for bid, the bidder does NOT expect to engage any major subcontractor to perform work under the Contract.

Signature of Authorized Representative of Bidder _____ Date _____

CONTRACT

THIS AGREEMENT is made on the _____ day of _____, 201_, between the CITY OF ANN ARBOR, a Michigan Municipal Corporation, 301 East Huron Street, Ann Arbor, Michigan 48104 ("City") and _____ ("Contractor")

(An individual/partnership/corporation, include state of incorporation)

(Address)

Based upon the mutual promises below, the Contractor and the City agree as follows:

ARTICLE I - Scope of Work

The Contractor agrees to furnish all of the materials, equipment and labor necessary; and to abide by all the duties and responsibilities applicable to it for the project titled [Insert Title of Bid and Bid Number] in accordance with the requirements and provisions of the following documents, including all written modifications incorporated into any of the documents, which are incorporated as part of this Contract:

Non-discrimination and Living Wage
Declaration of Compliance Forms (if
applicable)
Vendor Conflict of Interest Form
Prevailing Wage Declaration of
Compliance Form (if applicable)
Bid Forms
Contract and Exhibits
Bonds

General Conditions
Standard Specifications
Detailed Specifications
Plans
Addenda

ARTICLE II - Definitions

Administering Service Area/Unit means **Public Services Area, Engineering.**

Project means **Hoover, Greene, & Hill Improvement Project; City of Ann Arbor File No. 2018-031.**

ARTICLE III - Time of Completion

- (A) The work to be completed under this Contract shall begin immediately on the date specified in the Notice to Proceed issued by the City.
- (B) The entire work for this Contract shall be completed within One Hundred Twenty (120) consecutive calendar days.
- (C) Failure to complete all the work within the time specified above, including any extension granted in writing by the Supervising Professional, shall obligate the Contractor to pay the City, as liquidated damages and not as a penalty, an amount equal to \$2,500.00 for each calendar day of delay in the completion of all the work. If any liquidated damages are unpaid by the Contractor, the City shall be entitled to deduct these unpaid liquidated damages from the monies due the Contractor.

The liquidated damages are for the non-quantifiable aspects of any of the previously identified events and do not cover actual damages that can be shown or quantified nor are they intended to preclude recovery of actual damages in addition to the recovery of liquidated damages.

ARTICLE IV - The Contract Sum

- (A) The City shall pay to the Contractor for the performance of the Contract, the unit prices as given in the Bid Form for the estimated bid total of:

_____ Dollars (\$_____)

- (B) The amount paid shall be equitably adjusted to cover changes in the work ordered by the Supervising Professional but not required by the Contract Documents. Increases or decreases shall be determined only by written agreement between the City and Contractor.

ARTICLE V - Assignment

This Contract may not be assigned or subcontracted any portion of any right or obligation under this contract without the written consent of the City. Notwithstanding any consent by the City to any assignment, Contractor shall at all times remain bound to all warranties, certifications, indemnifications, promises and performances, however described, as are required of it under this contract unless specifically released from the requirement, in writing, by the City.

ARTICLE VI - Choice of Law

This Contract shall be construed, governed, and enforced in accordance with the laws of the State of Michigan. By executing this agreement, the Contractor and the City agree to venue in a court of appropriate jurisdiction sitting within Washtenaw County for purposes of any action arising under this Contract. The parties stipulate that the venue referenced in this Contract is for convenience and waive any claim of non-convenience.

Whenever possible, each provision of the Contract will be interpreted in a manner as to be effective and valid under applicable law. The prohibition or invalidity, under applicable law, of any provision will not invalidate the remainder of the Contract.

ARTICLE VII - Relationship of the Parties

The parties of the Contract agree that it is not a Contract of employment but is a Contract to accomplish a specific result. Contractor is an independent Contractor performing services for the City. Nothing contained in this Contract shall be deemed to constitute any other relationship between the City and the Contractor.

Contractor certifies that it has no personal or financial interest in the project other than the compensation it is to receive under the Contract. Contractor certifies that it is not, and shall not become, overdue or in default to the City for any Contract, debt, or any other obligation to the City including real or personal property taxes. City shall have the right to set off any such debt against compensation awarded for services under this agreement.

ARTICLE VIII - Notice

All notices given under this Contract shall be in writing, and shall be by personal delivery or by certified mail with return receipt requested to the parties at their respective addresses as specified in the Contract Documents or other address the Contractor may specify in writing. Notice will be deemed given on the date when one of the following first occur: (1) the date of actual receipt; or (2) three days after mailing certified U.S. mail.

ARTICLE IX - Indemnification

To the fullest extent permitted by law, Contractor shall indemnify, defend and hold harmless the City, its officers, employees and agents harmless from all suits, claims, judgments and expenses including attorney's fees resulting or alleged to result, in whole or in part, from any act or omission, which is in any way connected or associated with this Contract, by the Contractor or anyone acting on the Contractor's behalf under this Contract. Contractor shall not be responsible to indemnify the City for losses or damages caused by or resulting from the City's sole negligence. The provisions of this Article shall survive the expiration or earlier termination of this contract for any reason.

ARTICLE X - Entire Agreement

This Contract represents the entire understanding between the City and the Contractor and it supersedes all prior representations, negotiations, agreements, or understandings whether written or oral. Neither party has relied on any prior representations in entering into this Contract. No terms or conditions of either party's invoice, purchase order or other administrative document shall modify the terms and conditions of this Contract, regardless of the other party's failure to object to such form. This Contract shall be binding on and shall inure to the benefit of the parties to this Contract and their permitted successors and permitted assigns and nothing in this Contract, express or implied, is intended to or shall confer on any other person or entity any legal or equitable right, benefit, or remedy of any nature whatsoever under or by reason of this Contract. This Contract may be altered, amended or modified only by written amendment signed by the City and the Contractor.

FOR CONTRACTOR

By _____

Its: _____

FOR THE CITY OF ANN ARBOR

By _____
Christopher Taylor, Mayor

By _____
Jacqueline Beaudry, City Clerk

Approved as to substance

By _____
Howard S. Lazarus, City Administrator
City Administrator

By _____
Craig Hupy,
Public Services Area Administrator

Approved as to form and content

Stephen K. Postema, City Attorney

PERFORMANCE BOND

- (1) _____(referred to as "Principal"), and _____, a corporation duly authorized to do business in the State of Michigan (referred to as "Surety"), are bound to the City of Ann Arbor, Michigan (referred to as "City"), for \$ _____, the payment of which Principal and Surety bind themselves, their heirs, executors, administrators, successors and assigns, jointly and severally, by this bond.
- (2) The Principal has entered a written Contract with the City dated _____, 2019, for: The Hoover, Greene, & Hill Improvement Project; City of Ann Arbor File No. 2018-031; and this bond is given for that Contract in compliance with Act No. 213 of the Michigan Public Acts of 1963, as amended, being MCL 129.201 et seq.
- (3) Whenever the Principal is declared by the City to be in default under the Contract, the Surety may promptly remedy the default or shall promptly:
- (a) complete the Contract in accordance with its terms and conditions; or
 - (b) obtain a bid or bids for submission to the City for completing the Contract in accordance with its terms and conditions, and upon determination by Surety of the lowest responsible bidder, arrange for a Contract between such bidder and the City, and make available, as work progresses, sufficient funds to pay the cost of completion less the balance of the Contract price; but not exceeding, including other costs and damages for which Surety may be liable hereunder, the amount set forth in paragraph 1.
- (4) Surety shall have no obligation to the City if the Principal fully and promptly performs under the Contract.
- (5) Surety agrees that no change, extension of time, alteration or addition to the terms of the Contract or to the work to be performed thereunder, or the specifications accompanying it shall in any way affect its obligations on this bond, and waives notice of any such change, extension of time, alteration or addition to the terms of the Contract or to the work, or to the specifications.

SIGNED AND SEALED this _____ day of _____, 2019.

(Name of Surety Company)

By _____
(Signature)

Its _____
(Title of Office)

Approved as to form:

Stephen K. Postema, City Attorney

(Name of Principal)

By _____
(Signature)

Its _____
(Title of Office)

Name and address of agent:

LABOR AND MATERIAL BOND

- (1) _____
of _____(referred to as "Principal"), and _____, a corporation duly authorized to do business in the State of Michigan, (referred to as "Surety"), are bound to the City of Ann Arbor, Michigan (referred to as "City"), for the use and benefit of claimants as defined in Act 213 of Michigan Public Acts of 1963, as amended, being MCL 129.201 et seq., in the amount of \$ _____, for the payment of which Principal and Surety bind themselves, their heirs, executors, administrators, successors and assigns, jointly and severally, by this bond.
- (2) The Principal has entered a written Contract with the City, dated _____, 2019, for the Hoover, Greene, & Hill Improvement Project; City of Ann Arbor File No. 2018-031; and this bond is given for that Contract in compliance with Act No. 213 of the Michigan Public Acts of 1963 as amended;
- (3) If the Principal fails to promptly and fully repay claimants for labor and material reasonably required under the Contract, the Surety shall pay those claimants.
- (4) Surety's obligations shall not exceed the amount stated in paragraph 1, and Surety shall have no obligation if the Principal promptly and fully pays the claimants.

SIGNED AND SEALED this _____ day of _____, 2019

(Name of Surety Company)

By _____
(Signature)

Its _____
(Title of Office)

Approved as to form:

Stephen K. Postema, City Attorney

(Name of Principal)

By _____
(Signature)

Its _____
(Title of Office)

Name and address of agent:

GENERAL CONDITIONS

Section 1 - Execution, Correlation and Intent of Documents

The contract documents shall be signed in 2 copies by the City and the Contractor.

The contract documents are complementary and what is called for by any one shall be binding. The intention of the documents is to include all labor and materials, equipment and transportation necessary for the proper execution of the work. Materials or work described in words which so applied have a well-known technical or trade meaning have the meaning of those recognized standards.

In case of a conflict among the contract documents listed below in any requirement(s), the requirement(s) of the document listed first shall prevail over any conflicting requirement(s) of a document listed later.

(1) Addenda in reverse chronological order; (2) Detailed Specifications; (3) Standard Specifications; (4) Plans; (5) General Conditions; (6) Contract; (7) Bid Forms; (8) Bond Forms; (9) Bid.

Section 2 - Order of Completion

The Contractor shall submit with each invoice, and at other times reasonably requested by the Supervising Professional, schedules showing the order in which the Contractor proposes to carry on the work. They shall include the dates at which the Contractor will start the several parts of the work, the estimated dates of completion of the several parts, and important milestones within the several parts.

Section 3 - Familiarity with Work

The Bidder or its representative shall make personal investigations of the site of the work and of existing structures and shall determine to its own satisfaction the conditions to be encountered, the nature of the ground, the difficulties involved, and all other factors affecting the work proposed under this Contract. The Bidder to whom this Contract is awarded will not be entitled to any additional compensation unless conditions are clearly different from those which could reasonably have been anticipated by a person making diligent and thorough investigation of the site.

The Bidder shall immediately notify the City upon discovery, and in every case prior to submitting its Bid, of every error or omission in the bidding documents that would be identified by a reasonably competent, diligent Bidder. In no case will a Bidder be allowed the benefit of extra compensation or time to complete the work under this Contract for extra expenses or time spent as a result of the error or omission.

Section 4 - Wage Requirements

Under this Contract, the Contractor shall conform to Chapter 14 of Title I of the Code of the City of Ann Arbor as amended; which in part states "...that all craftsmen, mechanics and laborers employed directly on the site in connection with said improvements, including said employees of subcontractors, shall receive the prevailing wage for the corresponding classes of craftsmen,

mechanics and laborers, as determined by statistics for the Ann Arbor area compiled by the United States Department of Labor. At the request of the City, any contractor or subcontractor shall provide satisfactory proof of compliance with the contract provisions required by the Section.

Pursuant to Resolution R-16-469 all public improvement contractors are subject to prevailing wage and will be required to provide to the City payroll records sufficient to demonstrate compliance with the prevailing wage requirements. A sample Prevailing Wage Form is provided in the Appendix herein for reference as to what will be expected from contractors. Use of the Prevailing Wage Form provided in the Appendix section or a City-approved equivalent will be required along with wage rate interviews.

Where the Contract and the Ann Arbor City Ordinance are silent as to definitions of terms required in determining contract compliance with regard to prevailing wages, the definitions provided in the Davis-Bacon Act as amended (40 U.S.C. 278-a to 276-a-7) for the terms shall be used.

If the Contractor is a "covered employer" as defined in Chapter 23 of the Ann Arbor City Code, the Contractor agrees to comply with the living wage provisions of Chapter 23 of the Ann Arbor City Code. The Contractor agrees to pay those employees providing Services to the City under this Agreement a "living wage," as defined in Section 1:815 of the Ann Arbor City Code, as adjusted in accordance with Section 1:815(3); to post a notice approved by the City of the applicability of Chapter 23 in every location in which regular or contract employees providing services under this Agreement are working; to maintain records of compliance; if requested by the City, to provide documentation to verify compliance; to take no action that would reduce the compensation, wages, fringe benefits, or leave available to any employee or person contracted for employment in order to pay the living wage required by Section 1:815; and otherwise to comply with the requirements of Chapter 23.

Contractor agrees that all subcontracts entered into by the Contractor shall contain similar wage provision covering subcontractor's employees who perform work on this contract.

Section 5 - Non-Discrimination

The Contractor agrees to comply, and to require its subcontractor(s) to comply, with the nondiscrimination provisions of MCL 37.2209. The Contractor further agrees to comply with the provisions of Section 9:158 of Chapter 112 of Title IX of the Ann Arbor City Code, and to assure that applicants are employed and that employees are treated during employment in a manner which provides equal employment opportunity.

Section 6 - Materials, Appliances, Employees

Unless otherwise stipulated, the Contractor shall provide and pay for all materials, labor, water, tools, equipment, light, power, transportation, and other facilities necessary or used for the execution and completion of the work. Unless otherwise specified, all materials incorporated in the permanent work shall be new, and both workmanship and materials shall be of the highest quality. The Contractor shall, if required, furnish satisfactory evidence as to the kind and quality of materials.

The Contractor shall at all times enforce strict discipline and good order among its employees, and shall seek to avoid employing on the work any unfit person or anyone not skilled in the work assigned.

Adequate sanitary facilities shall be provided by the Contractor.

Section 7 - Qualifications for Employment

The Contractor shall employ competent laborers and mechanics for the work under this Contract. For work performed under this Contract, employment preference shall be given to qualified local residents.

Section 8 - Royalties and Patents

The Contractor shall pay all royalties and license fees. It shall defend all suits or claims for infringements of any patent rights and shall hold the City harmless from loss on account of infringement except that the City shall be responsible for all infringement loss when a particular process or the product of a particular manufacturer or manufacturers is specified, unless the City has notified the Contractor prior to the signing of the Contract that the particular process or product is patented or is believed to be patented.

Section 9 - Permits and Regulations

The Contractor must secure and pay for all permits, permit or plan review fees and licenses necessary for the prosecution of the work. These include but are not limited to City building permits, right-of-way permits, lane closure permits, right-of-way occupancy permits, and the like. The City shall secure and pay for easements shown on the plans unless otherwise specified.

The Contractor shall give all notices and comply with all laws, ordinances, rules and regulations bearing on the conduct of the work as drawn and specified. If the Contractor observes that the contract documents are at variance with those requirements, it shall promptly notify the Supervising Professional in writing, and any necessary changes shall be adjusted as provided in the Contract for changes in the work.

Section 10 - Protection of the Public and of Work and Property

The Contractor is responsible for the means, methods, sequences, techniques and procedures of construction and safety programs associated with the work contemplated by this contract. The Contractor, its agents or sub-contractors, shall comply with the "General Rules and Regulations for the Construction Industry" as published by the Construction Safety Commission of the State of Michigan and to all other local, State and National laws, ordinances, rules and regulations pertaining to safety of persons and property.

The Contractor shall take all necessary and reasonable precautions to protect the safety of the public. It shall continuously maintain adequate protection of all work from damage, and shall take all necessary and reasonable precautions to adequately protect all public and private property from injury or loss arising in connection with this Contract. It shall make good any damage, injury or loss to its work and to public and private property resulting from lack of reasonable protective precautions, except as may be due to errors in the contract documents, or caused by agents or employees of the City. The Contractor shall obtain and maintain sufficient insurance to cover damage to any City property at the site by any cause.

In an emergency affecting the safety of life, or the work, or of adjoining property, the Contractor is, without special instructions or authorization from the Supervising Professional, permitted to act at its discretion to prevent the threatened loss or injury. It shall also so act, without appeal, if authorized or instructed by the Supervising Professional.

Any compensation claimed by the Contractor for emergency work shall be determined by agreement or in accordance with the terms of Claims for Extra Cost - Section 15.

Section 11 - Inspection of Work

The City shall provide sufficient competent personnel for the inspection of the work.

The Supervising Professional shall at all times have access to the work whenever it is in preparation or progress, and the Contractor shall provide proper facilities for access and for inspection.

If the specifications, the Supervising Professional's instructions, laws, ordinances, or any public authority require any work to be specially tested or approved, the Contractor shall give the Supervising Professional timely notice of its readiness for inspection, and if the inspection is by an authority other than the Supervising Professional, of the date fixed for the inspection. Inspections by the Supervising Professional shall be made promptly, and where practicable at the source of supply. If any work should be covered up without approval or consent of the Supervising Professional, it must, if required by the Supervising Professional, be uncovered for examination and properly restored at the Contractor's expense.

Re-examination of any work may be ordered by the Supervising Professional, and, if so ordered, the work must be uncovered by the Contractor. If the work is found to be in accordance with the contract documents, the City shall pay the cost of re-examination and replacement. If the work is not in accordance with the contract documents, the Contractor shall pay the cost.

Section 12 - Superintendence

The Contractor shall keep on the work site, during its progress, a competent superintendent and any necessary assistants, all satisfactory to the Supervising Professional. The superintendent will be responsible to perform all on-site project management for the Contractor. The superintendent shall be experienced in the work required for this Contract. The superintendent shall represent the Contractor and all direction given to the superintendent shall be binding as if given to the Contractor. Important directions shall immediately be confirmed in writing to the Contractor. Other directions will be confirmed on written request. The Contractor shall give efficient superintendence to the work, using its best skill and attention.

Section 13 - Changes in the Work

The City may make changes to the quantities of work within the general scope of the Contract at any time by a written order and without notice to the sureties. If the changes add to or deduct from the extent of the work, the Contract Sum shall be adjusted accordingly. All the changes shall be executed under the conditions of the original Contract except that any claim for extension of time caused by the change shall be adjusted at the time of ordering the change.

In giving instructions, the Supervising Professional shall have authority to make minor changes in the work not involving extra cost and not inconsistent with the purposes of the work, but otherwise, except in an emergency endangering life or property, no extra work or change shall be made unless in pursuance of a written order by the Supervising Professional, and no claim for an addition to the Contract Sum shall be valid unless the additional work was ordered in writing.

The Contractor shall proceed with the work as changed and the value of the work shall be determined as provided in Claims for Extra Cost - Section 15.

Section 14 - Extension of Time

Extension of time stipulated in the Contract for completion of the work will be made if and as the Supervising Professional may deem proper under any of the following circumstances:

- (1) When work under an extra work order is added to the work under this Contract;
- (2) When the work is suspended as provided in Section 20;
- (3) When the work of the Contractor is delayed on account of conditions which could not have been foreseen, or which were beyond the control of the Contractor, and which were not the result of its fault or negligence;
- (4) Delays in the progress of the work caused by any act or neglect of the City or of its employees or by other Contractors employed by the City;
- (5) Delay due to an act of Government;
- (6) Delay by the Supervising Professional in the furnishing of plans and necessary information;
- (7) Other cause which in the opinion of the Supervising Professional entitles the Contractor to an extension of time.

The Contractor shall notify the Supervising Professional within 7 days of an occurrence or conditions which, in the Contractor's opinion, entitle it to an extension of time. The notice shall be in writing and submitted in ample time to permit full investigation and evaluation of the Contractor's claim. The Supervising Professional shall acknowledge receipt of the Contractor's notice within 7 days of its receipt. Failure to timely provide the written notice shall constitute a waiver by the Contractor of any claim.

In situations where an extension of time in contract completion is appropriate under this or any other section of the contract, the Contractor understands and agrees that the only available adjustment for events that cause any delays in contract completion shall be extension of the required time for contract completion and that there shall be no adjustments in the money due the Contractor on account of the delay.

Section 15 - Claims for Extra Cost

If the Contractor claims that any instructions by drawings or other media issued after the date of the Contract involved extra cost under this Contract, it shall give the Supervising Professional written notice within 7 days after the receipt of the instructions, and in any event before proceeding to execute the work, except in emergency endangering life or property. The procedure shall then be as provided for Changes in the Work-Section 13. No claim shall be valid unless so made.

If the Supervising Professional orders, in writing, the performance of any work not covered by the contract documents, and for which no item of work is provided in the Contract, and for which no unit price or lump sum basis can be agreed upon, then the extra work shall be done on a Cost-Plus-Percentage basis of payment as follows:

- (1) The Contractor shall be reimbursed for all reasonable costs incurred in doing the work, and shall receive an additional payment of 15% of all the reasonable costs to cover both its indirect overhead costs and profit;
- (2) The term "Cost" shall cover all payroll charges for employees and supervision required under the specific order, together with all worker's compensation, Social Security, pension and retirement allowances and social insurance, or other regular payroll charges on same; the cost of all material and supplies required of either temporary or permanent character; rental of all power-driven equipment at agreed upon rates, together with cost of fuel and supply charges for the equipment; and any costs incurred by the Contractor as a direct

result of executing the order, if approved by the Supervising Professional;

- (3) If the extra is performed under subcontract, the subcontractor shall be allowed to compute its charges as described above. The Contractor shall be permitted to add an additional charge of 5% percent to that of the subcontractor for the Contractor's supervision and contractual responsibility;
- (4) The quantities and items of work done each day shall be submitted to the Supervising Professional in a satisfactory form on the succeeding day, and shall be approved by the Supervising Professional and the Contractor or adjusted at once;
- (5) Payments of all charges for work under this Section in any one month shall be made along with normal progress payments. Retainage shall be in accordance with Progress Payments-Section 16.

No additional compensation will be provided for additional equipment, materials, personnel, overtime or special charges required to perform the work within the time requirements of the Contract.

When extra work is required and no suitable price for machinery and equipment can be determined in accordance with this Section, the hourly rate paid shall be 1/40 of the basic weekly rate listed in the Rental Rate Blue Book published by Dataquest Incorporated and applicable to the time period the equipment was first used for the extra work. The hourly rate will be deemed to include all costs of operation such as bucket or blade, fuel, maintenance, "regional factors", insurance, taxes, and the like, but not the costs of the operator.

Section 16 - Progress Payments

The Contractor shall submit each month, or at longer intervals, if it so desires, an invoice covering work performed for which it believes payment, under the Contract terms, is due. The submission shall be to the City's Finance Department - Accounting Division. The Supervising Professional will, within 10 days following submission of the invoice, prepare a certificate for payment for the work in an amount to be determined by the Supervising Professional as fairly representing the acceptable work performed during the period covered by the Contractor's invoice. To insure the proper performance of this Contract, the City will retain a percentage of the estimate in accordance with Act 524, Public Acts of 1980. The City will then, following the receipt of the Supervising Professional's Certificate, make payment to the Contractor as soon as feasible, which is anticipated will be within 15 days.

An allowance may be made in progress payments if substantial quantities of permanent material have been delivered to the site but not incorporated in the completed work if the Contractor, in the opinion of the Supervising Professional, is diligently pursuing the work under this Contract. Such materials shall be properly stored and adequately protected. Allowance in the estimate shall be at the invoice price value of the items. Notwithstanding any payment of any allowance, all risk of loss due to vandalism or any damages to the stored materials remains with the Contractor.

In the case of Contracts which include only the Furnishing and Delivering of Equipment, the payments shall be; 60% of the Contract Sum upon the delivery of all equipment to be furnished, or in the case of delivery of a usable portion of the equipment in advance of the total equipment delivery, 60% of the estimated value of the portion of the equipment may be paid upon its delivery in advance of the time of the remainder of the equipment to be furnished; 30% of the Contract Sum upon completion of erection of all equipment furnished, but not later than 60 days after the date of delivery of all of the equipment to be furnished; and payment of the final 10% on final completion of erection, testing and acceptance of all the equipment to be furnished; but not later than 180 days after the date of delivery of all of the equipment to be furnished, unless testing has been completed and shows the equipment to be unacceptable.

With each invoice for periodic payment, the Contractor shall enclose a Contractor's Declaration - Section 43, and an updated project schedule per Order of Completion - Section 2.

Section 17 - Deductions for Uncorrected Work

If the Supervising Professional decides it is inexpedient to correct work that has been damaged or that was not done in accordance with the Contract, an equitable deduction from the Contract price shall be made.

Section 18 - Correction of Work Before Final Payment

The Contractor shall promptly remove from the premises all materials condemned by the Supervising Professional as failing to meet Contract requirements, whether incorporated in the work or not, and the Contractor shall promptly replace and re-execute the work in accordance with the Contract and without expense to the City and shall bear the expense of making good all work of other contractors destroyed or damaged by the removal or replacement.

If the Contractor does not remove the condemned work and materials within 10 days after written notice, the City may remove them and, if the removed material has value, may store the material at the expense of the Contractor. If the Contractor does not pay the expense of the removal within 10 days thereafter, the City may, upon 10 days written notice, sell the removed materials at auction or private sale and shall pay to the Contractor the net proceeds, after deducting all costs and expenses that should have been borne by the Contractor. If the removed material has no value, the Contractor must pay the City the expenses for disposal within 10 days of invoice for the disposal costs.

The inspection or lack of inspection of any material or work pertaining to this Contract shall not relieve the Contractor of its obligation to fulfill this Contract and defective work shall be made good. Unsuitable materials may be rejected by the Supervising Professional notwithstanding that the work and materials have been previously overlooked by the Supervising Professional and accepted or estimated for payment or paid for. If the work or any part shall be found defective at any time before the final acceptance of the whole work, the Contractor shall forthwith make good the defect in a manner satisfactory to the Supervising Professional. The judgment and the decision of the Supervising Professional as to whether the materials supplied and the work done under this Contract comply with the requirements of the Contract shall be conclusive and final.

Section 19 - Acceptance and Final Payment

Upon receipt of written notice that the work is ready for final inspection and acceptance, the Supervising Professional will promptly make the inspection. When the Supervising Professional finds the work acceptable under the Contract and the Contract fully performed, the Supervising Professional will promptly sign and issue a final certificate stating that the work required by this Contract has been completed and is accepted by the City under the terms and conditions of the Contract. The entire balance found to be due the Contractor, including the retained percentage, shall be paid to the Contractor by the City within 30 days after the date of the final certificate.

Before issuance of final certificates, the Contractor shall file with the City:

- (1) The consent of the surety to payment of the final estimate;
- (2) The Contractor's Affidavit in the form required by Section 44.

In case the Affidavit or consent is not furnished, the City may retain out of any amount due the Contractor, sums sufficient to cover all lienable claims.

The making and acceptance of the final payment shall constitute a waiver of all claims by the City except those arising from:

- (1) unsettled liens;
- (2) faulty work appearing within 12 months after final payment;
- (3) hidden defects in meeting the requirements of the plans and specifications;
- (4) manufacturer's guarantees.

It shall also constitute a waiver of all claims by the Contractor, except those previously made and still unsettled.

Section 20 - Suspension of Work

The City may at any time suspend the work, or any part by giving 5 days notice to the Contractor in writing. The work shall be resumed by the Contractor within 10 days after the date fixed in the written notice from the City to the Contractor to do so. The City shall reimburse the Contractor for expense incurred by the Contractor in connection with the work under this Contract as a result of the suspension.

If the work, or any part, shall be stopped by the notice in writing, and if the City does not give notice in writing to the Contractor to resume work at a date within 90 days of the date fixed in the written notice to suspend, then the Contractor may abandon that portion of the work suspended and will be entitled to the estimates and payments for all work done on the portions abandoned, if any, plus 10% of the value of the work abandoned, to compensate for loss of overhead, plant expense, and anticipated profit.

Section 21 - Delays and the City's Right to Terminate Contract

If the Contractor refuses or fails to prosecute the work, or any separate part of it, with the diligence required to insure completion, ready for operation, within the allowable number of consecutive calendar days specified plus extensions, or fails to complete the work within the required time, the City may, by written notice to the Contractor, terminate its right to proceed with the work or any part of the work as to which there has been delay. After providing the notice the City may take over the work and prosecute it to completion, by contract or otherwise, and the Contractor and its sureties shall be liable to the City for any excess cost to the City. If the Contractor's right to proceed is terminated, the City may take possession of and utilize in completing the work, any materials, appliances and plant as may be on the site of the work and useful for completing the work. The right of the Contractor to proceed shall not be terminated or the Contractor charged with liquidated damages where an extension of time is granted under Extension of Time - Section 14.

If the Contractor is adjudged a bankrupt, or if it makes a general assignment for the benefit of creditors, or if a receiver is appointed on account of its insolvency, or if it persistently or repeatedly refuses or fails except in cases for which extension of time is provided, to supply enough properly skilled workers or proper materials, or if it fails to make prompt payments to subcontractors or for material or labor, or persistently disregards laws, ordinances or the instructions of the Supervising Professional, or otherwise is guilty of a substantial violation of any provision of the Contract, then the City, upon the certificate of the Supervising Professional that sufficient cause exists to justify such action, may, without prejudice to any other right or remedy and after giving the Contractor 3 days written notice, terminate this Contract. The City may then take possession of the premises and of all materials, tools and appliances thereon and without prejudice to any other remedy it may have, make good the deficiencies or finish the work by whatever method it may deem expedient, and deduct the cost from the payment due the Contractor. The Contractor shall not be entitled to receive any further payment until the work is finished. If the expense of finishing the work, including compensation for additional managerial and administrative services exceeds the unpaid balance of the Contract Sum, the Contractor and its surety are liable to the City for any

excess cost incurred. The expense incurred by the City, and the damage incurred through the Contractor's default, shall be certified by the Supervising Professional.

Section 22 - Contractor's Right to Terminate Contract

If the work should be stopped under an order of any court, or other public authority, for a period of 3 months, through no act or fault of the Contractor or of anyone employed by it, then the Contractor may, upon 7 days written notice to the City, terminate this Contract and recover from the City payment for all acceptable work executed plus reasonable profit.

Section 23 - City's Right To Do Work

If the Contractor should neglect to prosecute the work properly or fail to perform any provision of this Contract, the City, 3 days after giving written notice to the Contractor and its surety may, without prejudice to any other remedy the City may have, make good the deficiencies and may deduct the cost from the payment due to the Contractor.

Section 24 - Removal of Equipment and Supplies

In case of termination of this Contract before completion, from any or no cause, the Contractor, if notified to do so by the City, shall promptly remove any part or all of its equipment and supplies from the property of the City, failing which the City shall have the right to remove the equipment and supplies at the expense of the Contractor.

The removed equipment and supplies may be stored by the City and, if all costs of removal and storage are not paid by the Contractor within 10 days of invoicing, the City upon 10 days written notice may sell the equipment and supplies at auction or private sale, and shall pay the Contractor the net proceeds after deducting all costs and expenses that should have been borne by the Contractor and after deducting all amounts claimed due by any lien holder of the equipment or supplies.

Section 25 - Responsibility for Work and Warranties

The Contractor assumes full responsibility for any and all materials and equipment used in the construction of the work and may not make claims against the City for damages to materials and equipment from any cause except negligence or willful act of the City. Until its final acceptance, the Contractor shall be responsible for damage to or destruction of the project (except for any part covered by Partial Completion and Acceptance - Section 26). The Contractor shall make good all work damaged or destroyed before acceptance. All risk of loss remains with the Contractor until final acceptance of the work (Section 19) or partial acceptance (Section 26). The Contractor is advised to investigate obtaining its own builders risk insurance.

The Contractor shall guarantee the quality of the work for a period of one year. The Contractor shall also unconditionally guarantee the quality of all equipment and materials that are furnished and installed under the contract for a period of one year. At the end of one year after the Contractor's receipt of final payment, the complete work, including equipment and materials furnished and installed under the contract, shall be inspected by the Contractor and the Supervising Professional. Any defects shall be corrected by the Contractor at its expense as soon as practicable but in all cases within 60 days. Any defects that are identified prior to the end of one year shall also be inspected by the Contractor and the Supervising Professional and shall be corrected by the Contractor at its expense as soon as practicable but in all cases within 60 days. The Contractor shall assign all manufacturer or material supplier warranties to the City prior to final payment. The assignment shall not relieve the Contractor of its obligations under this paragraph to correct defects.

Section 26 - Partial Completion and Acceptance

If at any time prior to the issuance of the final certificate referred to in Acceptance and Final Payment - Section 19, any portion of the permanent construction has been satisfactorily completed, and if the Supervising Professional determines that portion of the permanent construction is not required for the operations of the Contractor but is needed by the City, the Supervising Professional shall issue to the Contractor a certificate of partial completion, and immediately the City may take over and use the portion of the permanent construction described in the certificate, and exclude the Contractor from that portion.

The issuance of a certificate of partial completion shall not constitute an extension of the Contractor's time to complete the portion of the permanent construction to which it relates if the Contractor has failed to complete it in accordance with the terms of this Contract. The issuance of the certificate shall not release the Contractor or its sureties from any obligations under this Contract including bonds.

If prior use increases the cost of, or delays the work, the Contractor shall be entitled to extra compensation, or extension of time, or both, as the Supervising Professional may determine.

Section 27 - Payments Withheld Prior to Final Acceptance of Work

The City may withhold or, on account of subsequently discovered evidence, nullify the whole or part of any certificate to the extent reasonably appropriate to protect the City from loss on account of:

- (1) Defective work not remedied;
- (2) Claims filed or reasonable evidence indicating probable filing of claims by other parties against the Contractor;
- (3) Failure of the Contractor to make payments properly to subcontractors or for material or labor;
- (4) Damage to another Contractor.

When the above grounds are removed or the Contractor provides a Surety Bond satisfactory to the City which will protect the City in the amount withheld, payment shall be made for amounts withheld under this section.

Section 28 - Contractor's Insurance

- (1) The Contractor shall procure and maintain during the life of this Contract, including the guarantee period and during any warranty work, such insurance policies, including those set forth below, as will protect itself and the City from all claims for bodily injuries, death or property damage which may arise under this Contract; whether the act(s) or omission(s) giving rise to the claim were made by the Contractor or by any subcontractor or anyone employed by them directly or indirectly. In the case of all contracts involving on-site work, the Contractor shall provide to the City, before the commencement of any work under this contract, certificates of insurance and other documentation satisfactory to the City demonstrating it has obtained the policies and endorsements required on behalf of itself, and when requested, any subcontractor(s). The certificates of insurance endorsements and/or copies of policy language shall document that the Contractor satisfies the following minimum requirements.

- (a) Worker's Compensation Insurance in accordance with all applicable state and federal statutes. Further, Employers Liability Coverage shall be obtained in the following minimum amounts:

Bodily Injury by Accident - \$500,000 each accident
Bodily Injury by Disease - \$500,000 each employee
Bodily Injury by Disease - \$500,000 each policy limit

- (b) Commercial General Liability Insurance equivalent to, as a minimum, Insurance Services Office form CG 00 01 07 98 or current equivalent. The City of Ann Arbor shall be named as an additional insured. There shall be no added exclusions or limiting endorsements specifically for the following coverages: Products and Completed Operations, Explosion, Collapse and Underground coverage or Pollution. Further there shall be no added exclusions or limiting endorsements which diminish the City's protections as an additional insured under the policy. The following minimum limits of liability are required:

\$1,000,000	Each occurrence as respect Bodily Injury Liability or Property Damage Liability, or both combined.
\$2,000,000	Per Job General Aggregate
\$1,000,000	Personal and Advertising Injury
\$2,000,000	Products and Completed Operations Aggregate

- (c) Motor Vehicle Liability Insurance, including Michigan No-Fault Coverages, equivalent to, as a minimum, Insurance Services Office form CA 00 01 07 97 or current equivalent. Coverage shall include all owned vehicles, all non-owned vehicles and all hired vehicles. The City of Ann Arbor shall be named as an additional insured. There shall be no added exclusions or limiting endorsements which diminish the City's protections as an additional insured under the policy. Further, the limits of liability shall be \$1,000,000 for each occurrence as respects Bodily Injury Liability or Property Damage Liability, or both combined.

- (d) Umbrella/Excess Liability Insurance shall be provided to apply excess of the Commercial General Liability, Employers Liability and the Motor Vehicle coverage enumerated above, for each occurrence and for aggregate in the amount of \$1,000,000.

- (2) Insurance required under subsection (1)(b) and (1)(c) above shall be considered primary as respects any other valid or collectible insurance that the City may possess, including any self-insured retentions the City may have; and any other insurance the City does possess shall be considered excess insurance only and shall not be required to contribute with this insurance. Further, the Contractor agrees to waive any right of recovery by its insurer against the City.
- (3) Insurance companies and policy forms are subject to approval of the City Attorney, which approval shall not be unreasonably withheld. Documentation must provide and demonstrate an unconditional 30 day written notice of cancellation in favor of the City of Ann Arbor. Further, the documentation must explicitly state the following: (a) the policy number; name of insurance company; name and address of the agent or authorized representative; name and address of insured; project name; policy expiration date; and specific coverage amounts; (b) any deductibles or self-insured retentions which shall be approved by the City, in its sole discretion; (c) that the policy conforms to the requirements specified Contractor shall furnish the City with satisfactory certificates of insurance and endorsements prior to commencement of any work. Upon request, the Contractor shall provide within 30 days a copy of the policy(ies) to the City. If any of the above coverages expire by their terms during the term of this Contract, the Contractor shall deliver proof of

renewal and/or new policies and endorsements to the Administering Service Area/Unit at least ten days prior to the expiration date.

- (4) Any Insurance provider of Contractor shall be admitted and authorized to do business in the State of Michigan and shall carry and maintain a minimum rating assigned by A.M. Best & Company's Key Rating Guide of "A-" Overall and a minimum Financial Size Category of "V". Insurance policies and certificates issued by non-admitted insurance companies are not acceptable unless approved in writing by the City.
- (5) City reserves the right to require additional coverage and/or coverage amounts as may be included from time to time in the Detailed Specifications for the Project.
- (6) The provisions of General Condition 28 shall survive the expiration or earlier termination of this contract for any reason.

Section 29 - Surety Bonds

Bonds will be required from the successful bidder as follows:

- (1) A Performance Bond to the City of Ann Arbor for the amount of the bid(s) accepted;
- (2) A Labor and Material Bond to the City of Ann Arbor for the amount of the bid(s) accepted.

Bonds shall be executed on forms supplied by the City in a manner and by a Surety Company authorized to transact business in Michigan and satisfactory to the City Attorney.

Section 30 - Damage Claims

The Contractor shall be held responsible for all damages to property of the City or others, caused by or resulting from the negligence of the Contractor, its employees, or agents during the progress of or connected with the prosecution of the work, whether within the limits of the work or elsewhere. The Contractor must restore all property injured including sidewalks, curbing, sodding, pipes, conduit, sewers or other public or private property to not less than its original condition with new work.

Section 31 - Refusal to Obey Instructions

If the Contractor refuses to obey the instructions of the Supervising Professional, the Supervising Professional shall withdraw inspection from the work, and no payments will be made for work performed thereafter nor may work be performed thereafter until the Supervising Professional shall have again authorized the work to proceed.

Section 32 - Assignment

Neither party to the Contract shall assign the Contract without the written consent of the other. The Contractor may assign any monies due to it to a third party acceptable to the City.

Section 33 - Rights of Various Interests

Whenever work being done by the City's forces or by other contractors is contiguous to work covered by this Contract, the respective rights of the various interests involved shall be established by the Supervising Professional, to secure the completion of the various portions of the work in general harmony.

The Contractor is responsible to coordinate all aspects of the work, including coordination of, and with, utility companies and other contractors whose work impacts this project.

Section 34 - Subcontracts

The Contractor shall not award any work to any subcontractor without prior written approval of the City. The approval will not be given until the Contractor submits to the City a written statement concerning the proposed award to the subcontractor. The statement shall contain all information the City may require.

The Contractor shall be as fully responsible to the City for the acts and omissions of its subcontractors, and of persons either directly or indirectly employed by them, as it is for the acts and omissions of persons directly employed by it.

The Contractor shall cause appropriate provisions to be inserted in all subcontracts relative to the work to bind subcontractors to the Contractor by the terms of the General Conditions and all other contract documents applicable to the work of the subcontractors and to give the Contractor the same power to terminate any subcontract that the City may exercise over the Contractor under any provision of the contract documents.

Nothing contained in the contract documents shall create any contractual relation between any subcontractor and the City.

Section 35 - Supervising Professional's Status

The Supervising Professional has the right to inspect any or all work. The Supervising Professional has authority to stop the work whenever stoppage may be appropriate to insure the proper execution of the Contract. The Supervising Professional has the authority to reject all work and materials which do not conform to the Contract and to decide questions which arise in the execution of the work.

The Supervising Professional shall make all measurements and determinations of quantities. Those measurements and determinations are final and conclusive between the parties.

Section 36 - Supervising Professional's Decisions

The Supervising Professional shall, within a reasonable time after their presentation to the Supervising Professional, make decisions in writing on all claims of the City or the Contractor and on all other matters relating to the execution and progress of the work or the interpretation of the contract documents.

Section 37 - Storing Materials and Supplies

Materials and supplies may be stored at the site of the work at locations agreeable to the City unless specific exception is listed elsewhere in these documents. Ample way for foot traffic and drainage must be provided, and gutters must, at all times, be kept free from obstruction. Traffic on streets shall be interfered with as little as possible. The Contractor may not enter or occupy with agents, employees, tools, or material any private property without first obtaining written permission from its owner. A copy of the permission shall be furnished to the Supervising Professional.

Section 38 - Lands for Work

The Contractor shall provide, at its own expense and without liability to the City, any additional land and access that may be required for temporary construction facilities or for storage of

materials.

Section 39 - Cleaning Up

The Contractor shall, as directed by the Supervising Professional, remove at its own expense from the City's property and from all public and private property all temporary structures, rubbish and waste materials resulting from its operations unless otherwise specifically approved, in writing, by the Supervising Professional.

Section 40 - Salvage

The Supervising Professional may designate for salvage any materials from existing structures or underground services. Materials so designated remain City property and shall be transported or stored at a location as the Supervising Professional may direct.

Section 41 - Night, Saturday or Sunday Work

No night or Sunday work (without prior written City approval) will be permitted except in the case of an emergency and then only to the extent absolutely necessary. The City may allow night work which, in the opinion of the Supervising Professional, can be satisfactorily performed at night. Night work is any work between 8:00 p.m. and 7:00 a.m. No Saturday work will be permitted unless the Contractor gives the Supervising Professional at least 48 hours but not more than 5 days notice of the Contractor's intention to work the upcoming Saturday.

Section 42 - Sales Taxes

Under State law the City is exempt from the assessment of State Sales Tax on its direct purchases. Contractors who acquire materials, equipment, supplies, etc. for incorporation in City projects are not likewise exempt. State Law shall prevail. The Bidder shall familiarize itself with the State Law and prepare its Bid accordingly. No extra payment will be allowed under this Contract for failure of the Contractor to make proper allowance in this bid for taxes it must pay.

Section 43

CONTRACTOR'S DECLARATION

I hereby declare that I have not, during the period _____, 20____, to _____, 20____, performed any work, furnished any materials, sustained any loss, damage or delay, or otherwise done anything in addition to the regular items (or executed change orders) set forth in the Contract titled _____, for which I shall ask, demand, sue for, or claim compensation or extension of time from the City, except as I hereby make claim for additional compensation or extension of time as set forth on the attached itemized statement. I further declare that I have paid all payroll obligations related to this Contract that have become due during the above period and that all invoices related to this Contract received more than 30 days prior to this declaration have been paid in full except as listed below.

There is/is not (Contractor please circle one and strike one as appropriate) an itemized statement attached regarding a request for additional compensation or extension of time.

Contractor

Date

By _____
(Signature)

Its _____
(Title of Office)

Past due invoices, if any, are listed below.

STANDARD SPECIFICATIONS

All work under this contract shall be performed in accordance with the Public Services Department Standard Specifications in effect at the date of availability of the contract documents stipulated in the Bid. All work under this Contract which is not included in these Standard Specifications, or which is performed using modifications to these Standard Specifications, shall be performed in accordance with the Detailed Specifications included in these contract documents.

Standard Specifications are available online:

<http://www.a2gov.org/departments/engineering/Pages/Engineering-and-Contractor-Resources.aspx>

DETAILED SPECIFICATIONS

CITY OF ANN ARBOR
DETAILED SPECIFICATION
FOR
CERTIFIED PAYROLL COMPLIANCE AND REPORTING

WT:VCM

1 of 2

01/17/19

a. Description.- This specification covers all administrative requirements, payroll reporting procedures to be followed by Contractors performing work on City-sponsored public improvements projects, and all other miscellaneous and incidental costs associated with complying with the applicable sections of the City of Ann Arbor Code of Ordinances with regard to payment of prevailing wages and its Prevailing Wage Compliance policy.

This specification is **not** intended to include the actual labor costs associated with the payment of prevailing wages as required. Those costs should be properly incorporated in all other items of work bid.

b. General.- The Contractor is expected to comply with all applicable sections of Federal and State prevailing wage laws, duly promulgated regulations, the City of Ann Arbor Code of Ordinances, and its Prevailing Wage Compliance Policy as defined within the contract documents. The Contractor shall provide the required certified payrolls, city-required declarations, and reports requested elsewhere in the contract documents within the timeline(s) stipulated therein.

The Contractor shall also provide corrected copies of any submitted documents that are found to contain errors, omissions, inconsistencies, or other defects that render the report invalid. The corrected copies shall be provided when requested by the Supervising Professional.

The Contractor shall also attend any required meetings as needed to fully discuss and ensure compliance with the contract requirements regarding prevailing wage compliance. The Contractor shall require all employees engaged in on-site work to participate in, provide the requested information to the extent practicable, and cooperate in the interview process. The City of Ann Arbor will provide the needed language interpreters in order to perform wage rate interviews or other field investigations as needed.

Certified Payrolls may be submitted on City-provided forms or forms used by the Contractor, as long as the Contractor's forms contain all required payroll information. If the Contractor elects to provide their own forms, the forms shall be approved by the Supervising Professional prior to the beginning of on-site work.

c. Unbalanced Bidding.- The City of Ann Arbor will examine the submitted cost for this item of work prior to contract award. If the City determines, in its sole discretion, that the costs bid by the Contractor for complying with the contract requirements are not

reasonable, accurately reported, or may contain discrepancies, the City reserves the right to request additional documentation that fully supports and justifies the price as bid. Should the submitted information not be determined to be reasonable or justify the costs, the City reserves the right to pursue award of the contract to the second low bidder without penalty or prejudice to any other remedies that it may have or may elect to exercise with respect to the original low-bidder.

The Contract Completion date will not be extended as a result of the City's investigation of the as-bid amount for this item of work, even if the anticipated contract award date must be adjusted. The only exception will be if the Contractor adequately demonstrates that their costs were appropriate and justifiable. If so, the City will adjust the contract completion date by the number of calendar days commensurate with the length of the investigation, if the published Notice to Proceed date of the work cannot be met. The contract unit prices for all other items of work will not be adjusted regardless of an adjustment of the contract completion date being made.

d. Measurement and Payment.- The completed work as measured for this item of work will be paid for at the Contract Unit Price for the following Contract (Pay) Item:

<u>Contract Item (Pay Item)</u>	<u>Pay Unit</u>
Item 201: Certified Payroll Compliance and Reporting	Lump Sum

The unit price for this item of work shall include all supervisory, accounting, administrative, and equipment costs needed to monitor and perform all work related to maintaining compliance with the tasks specified in this Detailed Specification, the City of Ann Arbor Code of Ordinances, its Prevailing Wage Compliance policy and the applicable Federal and State laws.

Payment for this work will be made with each progress payment, on a pro-rata basis, based on the percentage of construction completed. When all of the work of this contract has been completed, the measurement of this item shall be 1.0 times the Lump Sum bid amount. This amount will not be increased for any reason, including extensions of time, extra work, and/or adjustments to existing items of work.

CITY OF ANN ARBOR
DETAILED SPECIFICATION
FOR
GENERAL CONDITIONS, MAX. \$_____

WT:VCM	1 of 3	01/17/19
--------	--------	----------

a. **Description.**- This work shall consist of performing all needed preparatory work and operations needed to begin the work of the project. All elements of this item of work are to be performed in accordance with the City of Ann Arbor Standard Specifications for Construction (current edition), as shown on the plans, and as directed by the Engineer.

b. **Materials.**- None specified.

c. **Methods of Construction.**- This item shall include all work described and required by the Plans and Specifications for which no item of work is listed in the Bid Form, including but not limited to:

- Scheduling and organization of all work, subcontractors, suppliers, material testing, inspection, and construction surveying and staking;
- Coordination of, and cooperation with, other contractors, agencies, departments, and utilities;
- Coordination with City forces to stockpile and load used castings on City vehicles;
- Protection and maintenance of all existing utilities, including support, protection, capping, repair, replacement, connection or re-connection of existing pipes, and utilities damaged by the Contractor's operations;
- Maintaining and removing all soil erosion and sedimentation controls (as specified herein or as shown on project plans) for which no pay item exists;
- Maintaining the site, and all areas within the Construction Influence Area, in a well-graded and drained state at all times during the course of the project. De-watering and drainage of all excavations as required to maintain a stable, open hole;
- The continuous maintenance of the temporary road surface within the Construction Influence Area throughout the duration of the construction. This includes any needed grading to maintain the surface in a smooth condition free of potholes, ruts, bumps, or other objectionable conditions.
- Temporary sheeting, bracing, and shoring of excavations in accordance with the applicable MIOSHA Standards;
- Maintaining driveway openings, sidewalks, bike paths, mail deliveries, and solid waste/recycle pick-ups. This includes the placement and maintenance of maintenance aggregate in driveway openings and across sidewalk ramps all

- as needed and as directed by the Engineer;
- Using quantities of dust palliative, maintenance aggregate, and hot patching mixture for use as temporary base, surfacing, and dust control at utility crossings, side roads and driveways;
 - Storing all materials and equipment off lawn areas;
 - Temporary removal/re-location, storage, and re-installation/re-setting of existing street name, guide, and regulatory signs, mailboxes, newspaper tubes, etc. which conflict with the proposed construction;
 - Site clean-up on a daily basis during the course of the project's construction;
 - Coordination efforts to furnish the various required HMA mixtures as directed by the Engineer;
 - Coordination efforts to furnish and operate various-size vehicles/equipment as directed by the Engineer
 - Furnishing and operating vacuum-type street cleaning equipment a minimum of once per week, or more frequently, if directed by the Engineer;
 - Furnishing and operating vacuum-type utility structure cleaning equipment,
 - Furnishing and operating both vibratory plate and pneumatic-type ("pogo-stick") compactors;
 - Furnishing and operating a backhoe during all work activities;
 - Furnishing and operating a jackhammer and air compressor during all work activities;
 - Noise and dust control in accordance with the applicable City of Ann Arbor Ordinances;
 - Mobilization(s) and demobilization(s) of all needed materials, equipment, and personnel;
 - Furnishing of all required shop drawings, informational submittals, and material certifications for all needed materials and supplies incorporated into the project;
 - The proper off-site disposal of all excavated materials and debris;
 - Removal of shrubs, brush, and trees less than 6" diameter (DBH) as shown on the plan sheets or as directed by Engineer;
 - Trimming of trees and brush to accommodate intersection sight distance as shown on plans;

- Fencing to protect excavation over 1' in depth during non-work hours. The fencing must be a minimum of 36" high, be constructed of orange HDPE material, and reasonably secured to prevent unwanted access;
- All miscellaneous and incidental items such as overhead, insurance, and permits; and,
- Meeting all requirements relating to Debarment Certification, Davis Bacon Act, and Disadvantaged Business Enterprise, and providing the necessary documentation.

d. **Measurement and Payment.**- This item of work will be paid for on a pro-rata basis at the time of each progress payment. Measurement will be based on the ratio between work completed during the payment period and the total contract amount. When all of the work of this Contract has been completed, the measurement of this item shall be 1.0 Lump Sum, minus any deductions incurred for inadequate performance. This amount will not be increased for any reason, including extensions of time, extras, and/or additional work.

The completed work as measured for this item of work will be paid for at the contract unit price for the following contract item (pay item):

<u>Contract Item (Pay Item)</u>	<u>Pay Unit</u>
Item 202: General Conditions, Max. \$ _____ Lump Sum

The unit price for this item of work shall include all labor, material, and equipment costs to perform all the work specified in the City of Ann Arbor Standard Specifications for Construction and as modified by this Detailed Specification.

CITY OF ANN ARBOR
SPECIAL PROVISION
FOR
AUDIO-VISUAL RECORDING

WT:VCM

1 of 4

01/17/19

a. Description.- This work shall include providing a recording of the physical, structural, and aesthetic conditions of the construction site and adjacent areas as provided herein.

The audio-visual recording shall be:

1. Of professional quality, providing a clear and accurate audio and visual record of existing conditions.
2. Prepared during the three (3) week period immediately prior to the preconstruction meeting.
3. Furnished to the Engineer a minimum of two (2) weeks prior to bringing any materials or equipment within the areas described in this special provision.
4. Furnished to the Engineer either at, or prior to, the preconstruction meeting.
5. Carried-out under the supervision of the Engineer.

The Contractor shall furnish two (2) copies of the completed recording to the Engineer at, or prior to, the preconstruction meeting. An index of the recording, which will enable any area of the project to be easily found on the recording, shall be included. The Contractor shall retain a third copy of the recording for his/her own use.

Any portion of the recording determined by the Engineer to be unacceptable for the documentation of existing conditions shall be recorded again, at the Contractor's sole expense, and submitted to the Engineer prior to mobilizing onto the site.

b. Production.- The audio-visual recording shall be completed in accordance with the following minimum requirements:

1. DVD Format / No Editing.- The audio-visual recording shall be performed using equipment that allows audio and visual information to be recorded simultaneously and in color. The recording shall be provided on compact discs in DVD format. The quality of the recording shall be equal to or better than the standard in the industry. The recording shall not be edited.
2. Perspective / Speed / Pan / Zoom.- To ensure proper perspective, the distance from the ground to the camera lens shall not be less than 12 feet and the recording must proceed in the general direction of travel at a speed not to exceed 48 feet per minute (0.55 miles per hour). Pan and zoom rates shall be controlled sufficiently so that playback will ensure quality of the object viewed.

3. Display.- The recording equipment shall have transparent time, date stamp and digital annotation capabilities. The final copies of the recording shall continuously and simultaneously display the time (hours:minutes:seconds) and the date (month/date/year) in the upper left-hand corner of the frame. Accurate project stationing shall be included in the lower half of the frame in standard station format (i.e. 1+00). Below the stationing periodic information is to be shown, including project name, name of area shown, direction of travel, viewing direction, etc.

On streets or in areas where there is no project stationing, assumed stationing shall be used, starting with 0+00 and progressing from west to east or from north to south.

4. Audio Commentary / Visual Features. Locations relative to project limits and landmarks must be identified by both audio and video means at intervals no longer than 100 feet along the recording route. Additional audio commentary shall be provided as necessary during the recording to describe streets, buildings, landmarks, and other details, which will enhance the record of existing conditions.
5. Visibility / Ground Cover.- The recording shall be performed during a time of good visibility. The recording shall not be performed during periods of precipitation or when snow, leaves, or other natural debris obstruct the area being recorded.

c. Coverage.- The audio-visual recording coverage shall include the following:

1. General Criteria.- This general criteria shall apply to all recording and shall include all areas where construction activities will take place or where construction vehicles or equipment will be operated or parked and/or where materials will be stored or through which they will be transported. The recording shall extend an additional 50 feet outside of all areas. The recording shall include all significant, existing man-made and natural features such as driveways, sidewalks, utility covers, utility markers, utility poles, other utility features, traffic signal structures and features, public signs, private signs, fences, landscaping, trees, shrubs, other vegetation, and other similar or significant features.
2. Private Property.- Record all private property that may be utilized by the Contractor in conjunction with this project. These project areas must be disclosed by the Contractor prior to using them for the work of this project.
3. Road Construction Area.- The recording coverage shall:
 - a. Extend to 50 feet outside of the right-of-way and easements area as shown on the plans.
 - b. Extend 50 feet outside the construction limits on all streets, including side streets.

Both sides of each street shall be recorded separately.

4. Detour Route / Maintenance of Traffic Areas. The entire detour route, if one is provided for on the project plans, and maintenance of traffic areas shall be recorded as indicated in this special provision except as follows:
 - a. The recording must proceed in the general direction of travel at a speed not exceeding 176 feet per minute (2 miles per hour).
 - b. The coverage area shall include the street and not go beyond the curb except in areas where there is a fair possibility that the detoured traffic will drive over the curb, such as at intersections.
 - c. The recording shall focus in particular at sidewalk ramps and other features likely to have been damaged or likely to be damaged as a result of existing traffic, temporary detoured traffic and or construction traffic. In these areas, recording may need to proceed much more slowly.

Only the side of street with the detoured traffic must be recorded. However, the Contractor is advised that portions of the detour routes may operate in opposite directions at different times. In these cases, both sides of the street shall be recorded separately.

5. Private Property bordering the project limits or work areas – Hoover Ave from S. Main St. to S. State St.; Hill St. from Brown St. to S. Fifth Ave.; and Greene St. from Keech Ave. to Hill St. Record all areas bordering the project where work is scheduled to occur or where construction traffic could damage the private property. This is to including buildings, driveways, decks, landscaping, trees, lawns, and all other similar features.
6. Other Areas.- The Contractor shall record at his sole expense other areas where, in his/her opinion, the establishment of a record of existing conditions is warranted. The Contractor shall notify the Engineer in writing of such areas.

The Engineer may direct the recording of other minor areas not specified herein at the Contractor's sole expense.

d. Audio-Visual Recording Services.- The following companies are known to be capable of providing the recording services required by this special provision and shall be utilized, unless the Contractor receives prior written approval from the Engineer to utilize another company of comparable or superior qualifications.

Construction Video Media
Midwest Company
Topo Video, Inc.
Video Media Corp.
Paradigm 2000, Inc.
Finishing Touch Photo and Video

e. Measurement and Payment.- The completed work shall be paid for at the contract unit price for the following contract item (pay item):

<u>Contract Item (Pay Item)</u>	<u>Pay Unit</u>
Item 203: Audio-visual Recording	Lump Sum

Audio-visual Recording shall include all labor, equipment, and materials required to perform the recording and to provide the finished recording the Engineer.

Payment will be made for Audio-visual Recording following the review and acceptance of the recording by the Engineer. Within 21 days following the receipt of the recording, the Engineer will either accept it and authorize payment or require that any discrepancies in the recording be addressed prior to making payment.

CITY OF ANN ARBOR
DETAILED SPECIFICATION
FOR
MATERIAL AND SUPPLIES CERTIFICATIONS

WT:VCM

1 of 1

01/17/19

a. Description. This work includes furnishing certifications to the Engineer for review and approval a minimum of three business days prior to any scheduled delivery, installation, and/or construction of same. The following materials and supplies shall be certified by the manufacturer or supplier as having been tested for compliance with the Specifications:

- HMA materials
- Hot-poured Joint Sealants
- Cements, coatings, admixtures and curing materials
- Sands and Aggregates
- Steel and Fabricated metal
- Portland Cement Concrete Mixtures
- Reinforcing Steel for Concrete
- Reinforcing Fibers for Concrete
- Pre-cast Concrete products
- Storm Sewer Pipe
- Water Main Pipe and related materials
- Line stop materials
- Edge Drain and Underdrain Pipe
- Conduit
- Handholes
- Turf establishment materials
- Erosion Control materials

b. Materials. None specified.

c. Construction. Not specified.

d. Measurement and Payment. Costs for this work will not be paid for separately but shall be included in the Contract pay Item "General Conditions, Max. \$_____".

CITY OF ANN ARBOR
DETAILED SPECIFICATION
FOR
PROGRESS SCHEDULE

WT:VCM

1 of 3

01/17/19

a. Description.- Examination of Plans, Specifications, and Work Site: Bidders shall carefully examine the Bid Form, plans, specifications and the work site until the Bidder is satisfied as to all local conditions affecting the contract and the detailed requirements of construction. The submission of the bid shall be considered prima facie evidence that the Bidder has made such examination and is satisfied as to the conditions to be encountered in performing the work and all requirements of the contract.

The entire work under this Contract shall be completed in accordance with, and subject to, the scheduling requirements as outlined below, and all other requirements of the Contract Documents.

1. By no later than **April 8, 2019** the Contractor shall submit a detailed schedule (Gantt chart) of work for the Engineer's review and approval. The proposed schedule must fully comply with the scheduling requirements contained in this Detailed Specification. The Contractor shall update the approved work schedule each week and present it to the Engineer at the weekly progress meeting.
2. The Contractor will receive two (2) copies of the Contract, for his/her execution, on or before **April 8, 2019**. The Contractor shall properly execute both copies of the Contract and return them, with the required Bonds and Insurance Certificate, to the City by **April 15, 2019**.
3. Contractor may begin construction on the project on or before **April 22, 2019** and only after receiving the copy of executed contract documents and the Notice to Proceed from the City. Appropriate time extensions shall be granted if the Notice to Proceed is delayed due to the circumstances controlled by the City.
4. By **August 20, 2019** or within **one-hundred and twenty (120)** calendar days from the date of Notice to Proceed for the work on Hoover, Greene and Hill Improvement Project, the Contractor must install the new water main; all of the required service leads to the water main; all storm sewer and related work; and complete all the remaining work under this Contract for Hoover, Greene, & Hill Improvement Project including, but not limited to installation of the storm water structures, the restoration of all disturbed areas, permanent placement of hot mix asphalt and/or concrete, turf restoration, pavement markings, and the removal of any and all traffic control devices. Failure to complete all work as specified herein within the times specified herein, including time extensions granted thereto as determined by the Engineer, shall entitle the City to deduct from the payments due the Contractor "Liquidated Damages", and not as a penalty, for each and every calendar day beyond the allowed number of calendar days to complete the above specified work.

b. Phasing Sequence.- The work of this Contract is separated into three phases. The construction sequence for this project shall be as follows:

Phase I shall consist of Hoover Street, from Main Street to State Street, and Greene, from Hill Street to Keech Street constructed as part-width in two stages, with WB Hoover, EB Keech, and NB Greene traffic detoured at all times.

Phase IA shall consist of the full road closure of Hoover Street, from Greene Street to west of the Division Street. Closure shall begin on or after May 5, 2019 and be no longer than four (4) weeks in duration.

Phase IB shall consist of the full road closure of Hill Street, from near Adams Street to Fifth Avenue. Closure shall begin after completion of Phase IA and can occur simultaneously with Phase I work. Closure can be no longer than three (3) weeks in duration.

In order to allow sufficient time to complete the road construction of the project, any water main installation not begun by July 14, 2019 may, at the sole discretion of the Engineer, be postponed until the following construction season, or eliminated from this Contract entirely. If any portion of the project is postponed or eliminated, the Contractor must still complete all work on the remaining portion of the project, including paving up through the wearing course, within the current construction season. The Contractor will not be entitled to receive any additional compensation for the elimination or postponement of work from the enactment of this contract clause.

The Contractor may propose to adjust the limits or sequencing of construction in order to complete the work more efficiently. Changes to the recommended construction sequence must be approved in writing by the Engineer prior to construction and must assure all required coordination with other projects and time lines.

The City will not allow any shut down of existing water mains without prior written approval of construction methods and timing of shut down, by the City of Ann Arbor and the Engineer. All water main valves are to be operated by City of Ann Arbor personnel.

Time is of the essence in the performance of the work of this contract. The Contractor is expected to mobilize sufficient personnel and equipment, and work throughout all authorized hours in order to complete the project by the final completion date. Costs for the Contractor to organize, coordinate, and schedule all of the work of the project, will not be paid for separately, but shall be included in the bid price of the Contract Item "General Conditions, Max. \$_____"

Failure to complete all work as specified herein within the times specified herein, including time extensions granted thereto as determined by the Engineer, shall entitle the City to deduct from the payments due the Contractor, "Liquidated Damages", and not as a penalty, for delays in the completion of the work for each and every calendar day beyond the completion date for each sub-phase, as detailed in the phasing above.

Liquidated Damages will be assessed until the required work is completed in the current construction season. If, with the Engineer's approval, work is extended beyond seasonal limitations, the assessment of Liquidated Damages will be discontinued until the work is resumed in the following construction season.

MEASUREMENT AND PAYMENT

If the construction contract is not completed within the estimated 120 consecutive calendar days, and any extensions of time granted thereto, at the sole discretion of the City of Ann Arbor, this Contract may be terminated with no additional compensation due to the Contractor, and the Contractor may be forbidden to bid on future City of Ann Arbor projects for a period of at least three (3) years. If the Engineer elects to terminate the Contract, contract items paid for on a Lump Sum basis shall be paid up to a maximum percentage equal to the percentage of the contract work that has been completed.

Costs for the Contractor to organize, coordinate, and schedule all of the work of the project, will not be paid for separately, but shall be included in the bid price of the Contract Item "**General Conditions, Max.\$_____**" If the City elects to terminate this Construction Contract due to non-performance, contract items paid for on a Lump Sum basis will be pro-rated based on percentage equal to the percentage of the contract work completed.

CITY OF ANN ARBOR
DETAILED SPECIFICATION
FOR
UTILITY CLAUSE

WT:VCM

1 of 2

01/10/19

Utilities Coordination

The Contractor shall cooperate and coordinate construction activities with the owners of utilities as stated in subsection 104.08 of the Standard Specifications for Construction. In addition, for the protection of underground utilities, the Contractor shall follow the requirements in subsection 107.12 of the Standard Specifications for Construction. Contractor delay claims resulting from a utility will be determined based upon subsection 108.09 of the Standard Specifications for Construction.

The following Utility Owners, together with others, may have facilities located within the Right-of-Way:

<u>Utility</u>	<u>Type of Service</u>
City of Ann Arbor W.R. Wheeler Service Center 4251 Stone School Road Ann Arbor, MI 48108 734 794-6351	Sanitary Sewer (Pat Maino - ext. 43817) Water (Daniel Wooden - ext. 43324) Storm Sewer (Matthew Waldsmith - ext. 43321) Communications/Signs/Signals/Street Lighting (Chuck Fojtik - ext. 43322)
AT&T 550 South Maple Ann Arbor, MI 48103 Attn: Debora Renner 734-996-5485 debora.a.renner@att.com	Telephone/Fiber Optic
Comcast 27800 Franklin Road Southfield, MI 48034 Attn: Ron Southerland 248-359-6544 ronald_southerland@cable.comcast.com	Cable/Fiber Optic
DTE Energy 2000 2 nd Ave, Room 518 S.B. Detroit, MI 48226 Attn: Julie Gottardi 734-884-0585 gottardij@dteenergy.com	Electric
DTE Energy (Michcon) 17150 Allen Road Melvindale, MI 48122 Attn: Laurie Forrester 313-389-7261 forresterl@dteentergy.com	Gas

<u>Utility</u>	<u>Type of Service</u>
MCI/Verizon 5688 W Grand River Avenue Lansing, MI 48906 Attn: Rick Chalmers 517-318-8064 rick.chalmers@verizonbusiness.com	Telephone/Fiber Optic
Washtenaw County Water Resource Commissioner 705 N Zeeb Road P.O. Box 8645 Ann Arbor, MI 48107 734-222-6860	Allen Creek Drain

For protection of underground utilities, the Contractor shall call "MISS DIG" toll free at 1-800-482-7171 or call 811 a minimum of three (3) working days prior to excavation within the project limits. The Contractor must also notify utility owners who may not be part of the "MISS DIG" system.

The Contractor shall notify the City of Ann Arbor a minimum of three (3) days prior to beginning construction.

The Owners of public or private utilities which will not interfere with the completed project and which do not present a hazard to the public or an extraordinary hazard to the Contractor's operations will not be required to move their facilities on or from the street right-of-way.

The Contractor shall verify the location and depth of all utilities through Miss Dig and coordinate with the utilities to ensure that all utilities are protected during the project.

Protection of existing utility facilities is necessary during the project. Protection may include: holding utility poles, supporting underground facilities, temporary sheeting, bracing, poles, cables, sand fill or other means to complete the work. The Contractor is responsible for furnishing all labor, equipment and materials required to protect existing facilities during construction. Costs associated with protecting existing utilities will not be paid for separately, but shall be included in the bid price of the Contract Item "**General Conditions, Max \$_____**".

The following is a listing of known road and utility construction projects within the local vicinity that may have an impact on this project. Please note that this listing may not be complete and the Contractor shall verify any other projects within the local vicinity that may impact this project.

- Division Street Resurfacing
- DTE gas line relocation on Hoover
- Private site developments (151 E. Hoover, 327 E. Hoover, & 132 Hill)
- City of Ann Arbor Sidewalk Program on Hoover and Greene

CITY OF ANN ARBOR
DETAILED SPECIFICATION
FOR
RAILROAD REQUIREMENTS

WT:VCM

1 of 2

01/23/19

a. Description - This work consists of providing Railroad Protective Liability Insurance before work is commenced and kept in effect until all work required to be performed under the terms of the contract is satisfactorily completed as evidenced by the formal acceptance by the City of Ann Arbor (City).

b. Insurance Requirements- The Contractor shall maintain a policy of commercial general liability and for at least \$5,000,000.00 combined single limit, bodily injury and property damage per occurrence, \$5,000,000.00 aggregate. The policy shall include:

1. Completed operations liability
2. Contractual liability which would cover liabilities assumed under the contract with The Railroad
3. An endorsement deleting all exclusions for work performed near a railroad
4. An endorsement adding The Railroad as an additional insured and providing the Railroad 30 days' Notice of Cancellation or intent not to renew.

Further Contractor shall maintain a policy of railroad protective liability insurance for the benefit of Railroad in the amount of at least \$2,000,000.00 single limit and \$6,000,000.00 aggregate.

Contractor shall furnish certificates to Railroad and Owner and provide not less than 30 days' notice of cancellation or materials change in coverage. Certificate to Railroad shall be issued to:

ANN ARBOR RAILROAD, INC.
315 WEST 3RD STREET
PITTSBURG, KS 66762

The insurance herein specified must be with an acceptable insurance company authorized to do business in the State of Michigan and must be taken out before work is commenced and kept in effect until all work required to be performed under the terms of the contract is satisfactorily completed as evidenced by the formal acceptance by the City.

If any of the insurance is canceled, the Contractor and all subcontractors must cease operations as of the date of cancellation and cannot resume operations until new insurance is in force.

d. Measurement and Payment.- The Contractor must pay for railroad liability insurance. Insurance costs as described in this special provision will be included as part of “General Conditions, Max \$_____” pay item.

CITY OF ANN ARBOR
DETAILED SPECIFICATION
FOR
VACUUM TYPE CLEANING EQUIPMENT

WT:VCM

1 of 1

01/17/19

a. Description. This work includes furnishing and operating throughout the construction period, vacuum type street cleaning and utility structure cleaning equipment (Vac-All, Vactor, etc.) approved by the Engineer, as and when directed by the Engineer for dust control, for dirt/debris control, and for street cleaning immediately prior to paving, and for street and utility structure cleaning after any and all paving.

b. Materials. None specified.

c. Construction. The Contractor shall furnish and operate throughout the construction period, vacuum type street cleaning and utility structure cleaning equipment (Vac-All, Vactor, etc.) approved by the Engineer. When directed by the Engineer, the Contractor shall use this equipment to control dust, dirt, and other debris within the project limits and beyond as required, to clean streets surfaces immediately prior to placing HMA pavement mixtures, and for street and utility structure cleaning after any and all paving. The cleaning equipment shall be of sufficient power to remove dust, dirt, and debris from the pavement and from utility structures in and adjacent to the construction area.

d. Measurement and Payment. Costs for this work will not be paid for separately but shall be included in the Contract pay Item "General Conditions, Max \$_____".

CITY OF ANN ARBOR
DETAILED SPECIFICATION
FOR
**MAINTAINING TRAFFIC
AND
CONSTRUCTION SEQUENCING**

WT:VCM/CEW

1 of 9

01/28/19

General.- Traffic shall be maintained in accordance with Sections 104.11, 810, 811, 812, 919, and 920 of the Michigan Department of Transportation (MDOT) 2012 Standard Specifications for Construction, the 2011 edition of the Michigan Manual of Uniform Traffic Control Devices (MMUTCD) as amended, applicable supplemental specifications, as directed by the Engineer, except as herein provided.

The following, and herein included, Michigan Department of Transportation (MDOT) Maintaining Traffic Typical and Work Zone Device Details apply to the project: M0020a, M0040a, M0110a, M0140a, M0231a, M0240a, WZD-100-A, and WZD-125-E.

These maintaining traffic provisions are subject to change in the event of special community activities.

The Contractor shall furnish, erect, maintain and upon completion of the work remove all traffic control devices and warning lights within the project and around the perimeter of the project for the safety and protection of through and local traffic. This includes, but is not limited to; advance, regulatory, and warning signs; barricades and channeling devices at intersecting streets on which traffic is to be maintained; barricades at the ends of the project and at right-of-way lines of intersecting streets, temporary concrete barriers, temporary pedestrian paths and ramps, and moving traffic control devices for construction operations.

Materials.- The materials and equipment shall meet the requirements specified in the sections designated of the MDOT 2012 Standard Specifications for Construction, the MMUTCD, and all Special Provisions contained in these Contract Documents.

All signs shall be of sizes shown on the plans, unless otherwise directed by the Engineer. Install temporary signs that are to remain in the same place for 14 days or more on driven posts. Install all other temporary signs on portable supports. All signs shall have a minimum bottom height of 7.0 feet.

Channelizing devices required for all lane closures shall be plastic drums. 42 inch channelizing devices are permissible with approval from the Engineer.

Cold Patching Material shall meet the requirements of the City of Ann Arbor Standard Specifications for Construction and as approved by the Engineer.

Permits.- Prior to the start of construction, the Contractor shall obtain a "Right-of-Way" Permit from City of Ann Arbor Planning and Development Services and a "Lane Closure"

Permit from City of Ann Arbor Project Management Services Unit. The fees for these permits will be waived. The lane closure permit must be obtained at least 48 hours in advance of any proposed street or lane closing. Other permits are required.

Work Restrictions.- Only perform work on Sunday if it is of an emergency nature or if it is necessary to ensure vehicular and pedestrian traffic safety, and only perform it with prior approval by the City.

Perform no construction activities or interruptions to traffic, including lane closures, on Sundays and during the Memorial Day, U-M Graduations, Independence Day, and Labor Day holiday periods unless otherwise authorized by the Engineer. Contractor to coordinate with City and U-M on these and other restricted dates and provide detailed Gantt chart detailing work schedule. All streets and sidewalks that can be open shall be open to motorized and non-motorized traffic. The Engineer will also not permit any trucking on or off site during these times.

During non-working periods, any area with uncompleted work shall have plastic drums at specific locations and protective fencing, as directed by the Engineer, and at no additional cost to the project.

Do not impact traffic on major streets between the hours of 7:00 a.m. to 9:00 a.m. and from 3:30 p.m. to 6:00 p.m. unless otherwise approved by the Engineer or as specified on the Lane Closure Permit. Make all major changes in traffic control either between 9:00 a.m. and 3:30 p.m. or between 6:00 p.m. and 7:00 a.m. in order to minimize interference with rush hour traffic. All traffic controls must be in place and ready for traffic each day by 7:00 a.m. and 3:30 p.m. The Engineer will permit temporary obstruction of traffic for loading and unloading of trucks if the Contractor provides traffic regulators (flag persons) in conformance with Part VI of the MMUTCD. During temporary obstructions, a minimum of two traffic regulators are required.

Maintain access to businesses, residences, and side street(s) within the CIA for the duration of the project. The Contractor shall make every effort to coordinate its operations to minimize interruptions that may impact this access. The Contractor shall notify the Engineer forty-eight (48) hours in advance of any work planned on or near business or residential driveways, and stage work so that it is part-width when it is necessary to work in these areas. The Engineer will not allow the Contractor to prohibit access to businesses and residences during any phase of construction, unless agreed upon with the property owner(s). The Engineer may require traffic regulator (flag) control at its discretion and will direct the Contractor to provide it when necessary to maintain safe access to businesses, residences, and side street(s).

Construction Influence Area (CIA).- The CIA shall include the area from POB to POE within the Right-of-way of Greene St., Hoover Ave., and Hill St. The CIA shall also include the affected portions of the driveways along and contiguous with these roadways.

In addition, the CIA shall include the rights-of-way of all roadway segments used for detours and all locations that contain advance warning and/or regulatory signs, pavement markings, plastic drums, traffic delineators, and all other project related traffic maintenance items. The CIA shall also include those portions of private property outside of the roadway Rights-of-way as shown in the plans within the "Water Main Easement" areas.

Police and Fire.- The Contractor shall notify local police, fire departments and emergency response units a minimum of three business days (72 hours) prior to the closure of any roads, or traffic shifts causing restricted movements of traffic or restricted access.

Work Performed by City of Ann Arbor Signs and Signals Unit.- No additional or extra compensation will be paid for any delays caused by City of Ann Arbor Signs and Signals.

Signal Modifications

Signal timing and phasing modifications are anticipated for construction at the State Street and Hoover Avenue intersection. Modifications may also be required at the Main Street and Hill Street intersection, and the Main Street and Pauline Street intersection. Contractor shall coordinate work with the City ahead of changes in the traffic control.

Sign Reinstallation

As necessary during construction, the Contractor shall be responsible for logging the legend and location of any signs that:

1. Must be removed to facilitate the construction process;
2. Are to be permanently removed, or;
3. Are to be permanently relocated.

City of Ann Arbor Signs and Signals will remove and store the signs. After construction is complete, but before opening any roadway to traffic, Signs and Signals will reinstall all signs in their proper, permanent location. To coordinate sign removal and installation/reinstallation, the Contractor shall notify the Signs and Signals Unit at least five (5) working days (Monday-Friday) in advance of when the sign work will need to be completed. It is the responsibility of the Contractor to ensure that City of Ann Arbor Signs and Signals Unit is scheduled, kept apprised of the progress of construction, and notified a second time immediately (4 working hours) prior to the need to complete the sign work. The removal and installation/reinstallation of all signs shall be completed by the City of Ann Arbor Signs and Signals Unit.

Maintenance of Traffic, General.- Unless otherwise indicated on the drawings, residential side streets shall not be closed to through traffic except during construction operations of short duration and only with written approval of the Engineer.

The Contractor shall maintain at least one lane of through traffic along each street during the course of the Project's construction during non-working hours. Lane width

shall be a minimum of 10 feet wide. Contractor shall schedule work in order to maintain traffic flow and under no circumstances stop traffic for prolonged periods as determined by the Engineer. The Contractor shall suspend work within the CIA during peak traffic hours and/or when construction activities are unduly hampering or delaying traffic flow as determined by the Engineer.

Mailboxes requiring relocation due to construction shall be removed and reset immediately by the Contractor in a temporary location approved by the Engineer and meeting the requirements of the United States Postal Service. This work shall be included in the contract pay item "General Conditions, Max. \$_____".

The Contractor shall coordinate his operations with all Utilities, Contractors and/or sub-Contractors performing work on this and other projects within, or adjacent to, the Construction Influence Area (CIA). The contractor shall avoid conflicts in maintaining traffic operations, signing, and orderly progress of other contract work.

Maintenance.- A minimum of one (1) driveway shall be maintained at all times to all residences and businesses. Walks, driveways, and entrances to houses shall not be blocked. Vehicular and pedestrian access shall be maintained to all properties.

Exploratory Excavations, utility crossings, and all other openings created by the Work over which vehicular traffic will be maintained shall receive a minimum cover of 3 inches of Cold-Patching material that is thoroughly compacted in place.

Signs and Pavement Markings.- When lane closures are in place, the Contractor shall completely cover all conflicting warning, regulatory and guide signs in accordance with Section 812.03.D.2 of the Standard Specifications for Construction, 2012 edition, and all applicable details therein.

Construction.- This provision does not detail all the project work. It is intended to indicate major project requirements and assist the Contractor in developing, for the review and approval of the Engineer, the Progress Schedule for the project.

The Contractor shall notify the Engineer a minimum of 5 working days prior to the implementation of any detours, road closures, ramp or lane closures, and major traffic shifts. The Contractor shall also notify City of Ann Arbor Signs and Signals regarding signal work as specified in the section entitled "Work Performed by City of Ann Arbor Signs and Signals Unit."

Contractor required to perform dewatering required to construct utilities. All storm sewer on mainline systems shall be reconnected prior to leaving the work site each day to maintain drainage flows. If contractor cannot reconnect the piping system at the end of each day, then the Contractor shall provide, install, and maintain bypass pumping equipment, operations and related supervision at no additional cost.

Phase I: Hoover Avenue and Keech/Greene Street Work & Detour Routes

Hoover, Greene and Keech work shall be performed using part-width construction and maintain one-lane of one-way traffic operations.

Hoover Avenue will maintain eastbound traffic and detour westbound traffic. The westbound detour will utilize State Street to Packard to Hill Street to Main Street.

Channelizing devices will be used to close the left turn lane (with sign R3-2) NB State St and right turn lane (with sign R3-1) on SB State St to prevent wrong way traffic on Hoover.

Greene and Keech will maintain southbound and westbound traffic and detour northbound and eastbound traffic, respectively. The detour will utilize Main Street to Hoover Ave for Keech, and Main Street to Hill Street for Greene. The contractor will remove and reinstall the westbound stop bar at Hill Street and Main Street intersection, as directed by the Engineer, to accommodate right turns by large vehicles.

Westbound Hoover is closed at all times with construction in two stages – one stage to construct each bound of traffic.

Northbound Greene and eastbound Keech is closed at all times with construction in two stages – one stage to construct each bound of traffic.

Coordinate maintenance of traffic with Division resurfacing project.

Maintain traffic operations at the Hoover/Greene/Keech intersection, Main Street/Hoover intersection, and State Street/Hoover intersection at all times.

The Main Street/Hoover intersection work will require a closure of NB Main Street traffic for one weekend. The detour will be to Pauline Boulevard, to Seventh Street, to Madison Street. SB Main Street traffic will be reduced to one lane. All lanes must be open to traffic by the end of the day.

The State Street/Hoover Ave intersection work will be completed in one weekend will require a full closure of EB Hoover Ave at this intersection. State Street will maintain one lane in each direction. EB Hoover Ave will be detoured to Division Street, to Hill Street, to State Street.

Phase IA: Hoover Avenue Full-Closure & Detour Routes

Hoover Avenue will be closed down for four (4) weeks between Greene Road and Division Street to allow for the water main jack-and-bore installation, water main work, storm sewer work, gas line installation, 3-inch conduit installation, and related road and sidewalk construction.

Hoover Closure shall begin on or after May 5, 2019. Hoover Closure and related work cannot overlap with Hill Street Closure and related work.

Division Street must be open to 2-way traffic flow from Hill Street to Hoover Avenue.

The detours for Hoover Avenue, Greene Street, and Keech Street will remain in effect. An additional detour will be required along Greene (south of Hoover) to Keech, to Main Street, to Hill Street, to Division and returning to Hoover Avenue.

Maintain traffic operations at the Hoover/Greene/Keech intersection, Main Street/Hoover intersection, and State Street/Hoover intersection at all times.

Phase IB: Hill Street Full-Closure & Detour Routes

Hill Street will be closed down for three (3) weeks between Adams Avenue and Fifth Avenue to allow for the water main jack-and-bore installation, water main work, 3-inch conduit installation, and related road and sidewalk construction.

Hill Closure shall begin after the Phase IA work is completed and reopened to one-way traffic. Hill Closure and related work cannot overlap with Hoover Avenue Closure and related work. Phase IB work shall occur simultaneously with Phase I work.

Maintain traffic operations at the Hoover/Greene/Keech intersection, Main Street/Hoover intersection, and State Street/Hoover intersection at all times.

The detours for Hoover Avenue, Greene Street, and Keech Street will remain in effect with the following modifications. The detour route for westbound Hoover will route on State Street, to Stadium, to Hill, to Fifth, to Madison, to Main Street and return to Hoover.

Eastbound and westbound Hill detours will be routed on Hill-Madison-Main Street.

The intersection at Hill and Fifth shall remain open to traffic at all times. The contractor will be allowed to close the Hill/Fifth intersection for one weekend (within the 3-week closure) to perform pavement removals, water main, service, and connection installations, aggregate placement, paving, restorations, and related work. Detours to be modified and routed on Hill, Division, Madison, and Main Street during this intersection closure.

Pedestrians and Bicyclists

If the work involves closing a bicycle lane, BICYCLE (sym) W11-1 and SHARE THE ROAD W16-1P will be used to direct bicycle traffic into the vehicular lane.

For work on the north side of Hoover, a pedestrian detour is used and detours pedestrians to the south side of Hoover. When the south side of Hoover is under construction, every other pedestrian crossing must be maintained. Use the included typical to close the appropriate crossings.

For work affecting pedestrian crossings, use the included typical details to maintain pedestrian traffic.

Major Work Tasks - The following major work tasks are included in each stage of work:

1. Implement the traffic control as shown on the project plans, and as directed by the Engineer for this stage of the construction. Coordinate with the City of Ann Arbor Signs and Signals Unit as needed.
2. Install all needed soil erosion and sedimentation control measures. The Contractor shall install only those devices necessary to perform the work of this particular stage or to meet the appropriate Federal, State, or Local regulations.
3. Remove only road and sidewalk surfaces necessary to facilitate utility construction using part-width construction. Maintain HMA road surface for travel and pedestrian sidewalk access.
4. Install water main, test, accept, connect to system and install leads. The Contractor shall provide reasonable access for vehicles and pedestrians to all residences at all times during construction.
5. Install water services. The Contractor is to maintain traffic at all times. The lead trench shall be backfilled and compacted to asphalt surface and maintained.
6. Coordinate with DTE gas line installation.
7. Install storm water sewer and manholes and related sanitary sewer improvements.
8. Install 3-inch conduit, handholes, and related work.
9. Place and compact aggregate base course as directed by the Engineer.
10. Fine grade aggregate base course.
11. Construction of bituminous base course. Place HMA material as shown on the plans and as directed by the Engineer. Provide the needed traffic control devices to perform this work and maintain traffic as approved by the Engineer.
12. Completion of restoration and all other construction activities, except as indicated in the following line item.
13. Coordinate with City and install all signing. Temporarily cover signs in conflict with construction maintenance of traffic.
14. Construction of the bituminous wearing course:

- a. Immediately prior to paving the wearing course, adjust structure covers.
- b. Place bituminous wearing course. Provide the needed traffic control devices to perform this work and maintain traffic as approved by the Engineer.
- c. Place any required pavement markings.

15. Install pavement markings.

16. Reasonable access to all side streets and driveways shall be maintained at all times. The Contractor is to coordinate construction in front of driveways, and the actual driveway construction (where applicable), with affected property owners as detailed elsewhere herein.

Bituminous Paving.- The Contractor shall perform the work of this Contract while maintaining traffic in accordance with Contract Documents as specified herein. No traffic shall be allowed on newly placed asphalt surfaces until rolling has been satisfactorily completed and the surface has cooled sufficiently to prevent damage from traffic. This is to be accomplished by traffic regulators (flag persons) and by relocating traffic control devices to prevent traffic from entering the work area until such time that traffic can be safely maintained without damaging the new construction. The Contractor shall provide traffic regulators in sufficient number to maintain traffic as described herein, and to keep traffic off sections being surfaced, and provide for safe travel at all times as directed by the Engineer.

Each pressure distributor, paver and roller shall be equipped with at least one approved flasher light which shall be mounted on the equipment so as to give a warning signal ahead and behind.

The paving of the top course shall be conducted under traffic by utilizing traffic regulators (flag persons), channelizing devices and signs in accordance with Part VI of the current edition of the Michigan Manual of Uniform Traffic Control devices (MMUTCD) as amended. The installation and removal of minor traffic control devices needed for the maintenance of traffic during the paving of final wearing course and the furnishing of traffic regulators shall be paid as "Minor Traffic Devices" and "Traffic Regulator Control" as appropriate.

Measurement and Payment.- The estimated quantities for maintaining traffic is based on the maintenance of traffic plans. Any additional signing, traffic control devices, pavement markings, or the like required to expedite the construction, beyond that which is specified, shall be at the Contractor's sole expense.

The completed work as measured shall be paid at the contract unit price for the following contract pay items:

Contract Pay Item

Pay Unit

Item 204: Traffic Regulator Control	Lump Sum
Item 205: Barricade, Type III, High Intensity, Lighted, Furn & Oper	Each
Item 206: Channelizing Device, 42 inch, High Intensity, Furn & Oper	Each
Item 207: Plastic Drums, High Intensity, Furn & Oper	Each
Item 208: Sign, Type B, Temp, Prismatic, Special, Furn & Oper.....	Square Foot
Item 209: Sign Type A, Temp, Prismatic, Furn & Oper	Square Foot
Item 210: Sign, Type B, Temp, Prismatic, Furn & Oper	Square Foot
Item 211: Lighted Arrow, Type C, Furn & Oper	Each
Item 212: Sign, Portable, Changeable Message, NTFCIP-Compliant, Furn & Oper .	Each
Item 213: Remove Special Marking.....	Square Foot
Item 214: Concrete Barrier, Temp, Furn & Oper	Feet
Item 215: Sign Cover.....	Each

The unit price for this item of work shall include all labor, material, and equipment costs required to perform the work specified herein and includes both furnishing and operating the devices.

MINIMUM MERGING TAPER LENGTH "L" (FEET)

OFFSET FEET	POSTED SPEED LIMIT, MPH (PRIOR TO WORK AREA)									
	25	30	35	40	45	50	55	60	65	70
1	10	15	20	27	45	50	55	60	65	70
2	21	30	41	53	90	100	110	120	130	140
3	31	45	61	80	135	150	165	180	195	210
4	42	60	82	107	180	200	220	240	260	280
5	52	75	102	133	225	250	275	300	325	350
6	63	90	123	160	270	300	330	360	390	420
7	73	105	143	187	315	350	385	420	455	490
8	83	120	163	213	360	400	440	480	520	560
9	94	135	184	240	405	450	495	540	585	630
10	104	150	204	267	450	500	550	600	650	700
11	115	165	225	293	495	550	605	660	715	770
12	125	180	245	320	540	600	660	720	780	840
13	135	195	266	347	585	650	715	780	845	910
14	146	210	286	374	630	700	770	840	910	980
15	157	225	307	400	675	750	825	900	975	1050

TAPER LENGTH "L" IN FEET

THE FORMULAS FOR THE MINIMUM LENGTH OF A MERGING TAPER IN DERIVING THE "L" VALUES SHOWN IN THE ABOVE TABLES ARE AS FOLLOWS:

"L" = $\frac{W \times S^2}{60}$ WHERE POSTED SPEED PRIOR TO THE WORK AREA IS 40 MPH OR LESS

"L" = S x W WHERE POSTED SPEED PRIOR TO THE WORK AREA IS 45 MPH OR GREATER

- L = MINIMUM LENGTH OF MERGING TAPER
- S = POSTED SPEED LIMIT IN MPH PRIOR TO WORK AREA
- W = WIDTH OF OFFSET

TYPES OF TAPERS

UPSTREAM TAPERS

- MERGING TAPER
- SHIFTING TAPER
- SHOULDER TAPER
- TWO-WAY TRAFFIC TAPER

DOWNSTREAM TAPERS

(USE IS OPTIONAL)

TAPER LENGTH

- L - MINIMUM
- 1/2 L - MINIMUM
- 1/3 L - MINIMUM
- 100' - MAXIMUM
- 100' - MINIMUM (PER LANE)

 TRAFFIC AND SAFETY MAINTAINING TRAFFIC TYPICAL	TABLES FOR "L", "D" AND "B" VALUES		
	DRAWN BY: CON:AE:djf CHECKED BY: BMM	JUNE 2006 PLAN DATE:	M0020a
FILE: C:\CON\TSR\STDS\ENGLISH\MNTTRF\M0020a.dgn REV. 08/21/2006			

DS-28

DISTANCE BETWEEN TRAFFIC CONTROL DEVICES "D"
AND LENGTH OF LONGITUDINAL BUFFER SPACE ON
"WHERE WORKERS PRESENT" SEQUENCES

"D" DISTANCES	POSTED SPEED LIMIT, MPH (PRIOR TO WORK AREA)									
	25	30	35	40	45	50	55	60	65	70
D (FEET)	250	300	350	400	450	500	550	600	650	700

GUIDELINES FOR LENGTH OF
LONGITUDINAL BUFFER SPACE "B"

SPEED* MPH	LENGTH FEET
20	33
25	50
30	83
35	132
40	181
45	230
50	279
55	329
60	411
65	476
70	542

* POSTED SPEED, OFF PEAK 85TH PERCENTILE SPEED PRIOR TO WORK STARTING, OR THE ANTICIPATED OPERATING SPEED

1 BASED UPON AMERICAN ASSOCIATION OF STATE HIGHWAY AND TRANSPORTATION OFFICIALS (AASHTO) BRAKING DISTANCE PORTION OF STOPPING SIGHT DISTANCE FOR WET AND LEVEL PAVEMENTS (A POLICY ON GEOMETRIC DESIGN OF HIGHWAY AND STREETS), AASHTO. THIS AASHTO DOCUMENT ALSO RECOMMENDS ADJUSTMENTS FOR THE EFFECT OF GRADE ON STOPPING AND VARIATION FOR TRUCKS.

 TRAFFIC AND SAFETY MAINTAINING TRAFFIC TYPICAL	TABLES FOR "L", "D" AND "B" VALUES		
	DRAWN BY: CON:AE:djf CHECKED BY: BMM	JUNE 2006 PLAN DATE:	M0020a
FILE: \\snp\tsr\stds\english\mnttrf\M0020a.dgn REV. 08/21/2006			

DS-29

SIGN PLACEMENT IS THE SAME FOR BOTH DIRECTIONS

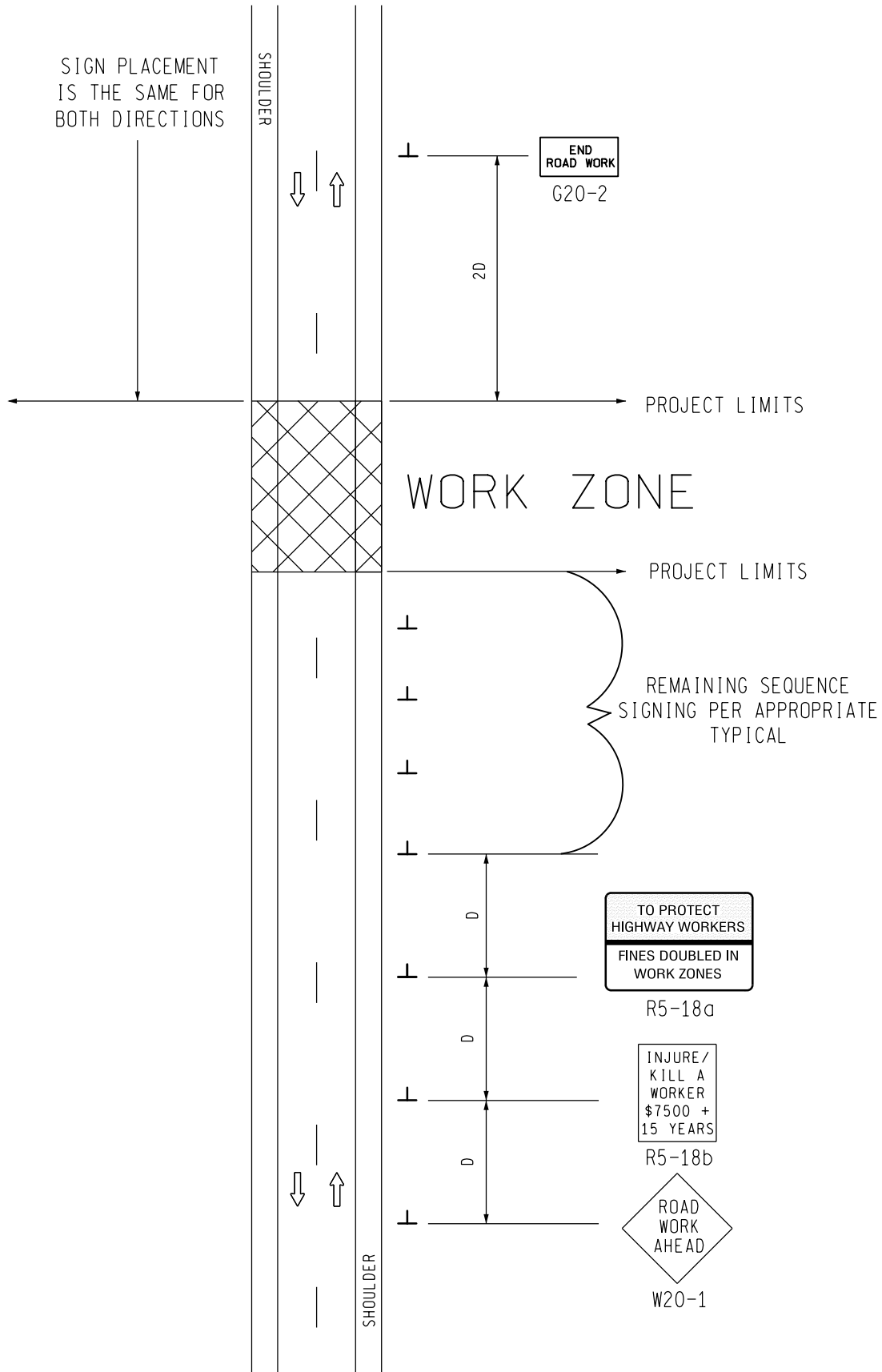

SIGN = 68 f+2 - TYPE B
 FOR ONE DIRECTION OF TRAFFIC
 W20-1 QUANTITY INCLUDED
 WITH APPROPRIATE TYPICAL
 FOR SEQUENCE SIGNING

MDOT
 Michigan Department of Transportation
 TRAFFIC AND SAFETY
 MAINTAINING TRAFFIC
 TYPICAL

TYPICAL ADVANCE SIGNING TREATMENT FOR LONG, INTERMEDIATE AND SHORT TERM STATIONARY WORK ZONE OPERATIONS OF LESS THAN TWO MILES IN LENGTH WHERE TRAFFIC CONTROL DEVICES MAY REMAIN AT END OF WORK DAY ON AN UNDIVIDED TWO-WAY ROADWAY

DRAWN BY: CON:AE:djf
 CHECKED BY: BMM:CRB
 DS-30

OCTOBER 2011
 PLAN DATE:

M0040a

SHEET
 1 OF 2

NOT TO SCALE

NOTES

30. THE APPROPRIATE ADVANCE SIGNING SEQUENCE(S), (M0030a THROUGH M0080a) SHALL BE USED ON ALL PROJECTS.
32. THESE SIGNS SHALL BE LEFT IN PLACE AT THEIR PRESCRIBED LOCATIONS FOR THE DURATION OF THE PROJECT AND UNTIL ALL TEMPORARY TRAFFIC CONTROL HAS BEEN REMOVED.
35. THESE SIGNS ARE INTENDED TO BE USED WITHIN THE LIMITS OF THE TEMPORARY SEQUENCE SIGNING AS IS SHOWN ON 1 OF 2. THESE SIGNS ARE NOT TO BE INTERMINGLED WITH ANY OTHER TEMPORARY SEQUENCE SIGNING EXCEPT AS SHOWN.



SIGN SIZES

G20-2	-	48" x 24"
R5-18a	-	96" x 60"
R5-18b	-	48" x 60"
W20-1	-	48" x 48"

 TRAFFIC AND SAFETY MAINTAINING TRAFFIC TYPICAL	TYPICAL ADVANCE SIGNING TREATMENT FOR LONG, INTERMEDIATE AND SHORT TERM STATIONARY WORK ZONE OPERATIONS OF LESS THAN TWO MILES IN LENGTH WHERE TRAFFIC CONTROL DEVICES MAY REMAIN AT END OF WORK DAY ON AN UNDIVIDED TWO-WAY ROADWAY	
	DRAWN BY: CON:AE:djf	OCTOBER 2011
CHECKED BY: BMM:CRB	PLAN DATE:	2 OF 2
FILE: PW RD/TS/Typicals/Signs/MT NON FWY/M0040a.dgn		REV. 10/13/2011

NOT TO SCALE

KEY

- • • CHANNELIZING DEVICES
-  LIGHTED ARROW PANEL (CAUTION MODE)
-  TRAFFIC FLOW
- REFLECTS EXISTING SPEED LIMIT
- * USE THE "NEXT -- MILES" SIGN WHEN SHOULDER CLOSURE EXCEEDS 1 MILE IN LENGTH

SIGN = 120 ft± - TYPE B
 W/PLAQUE = 132 ft± - TYPE B
 PLUS ADDITIONAL R2-1's
 THROUGHOUT WORK AREA

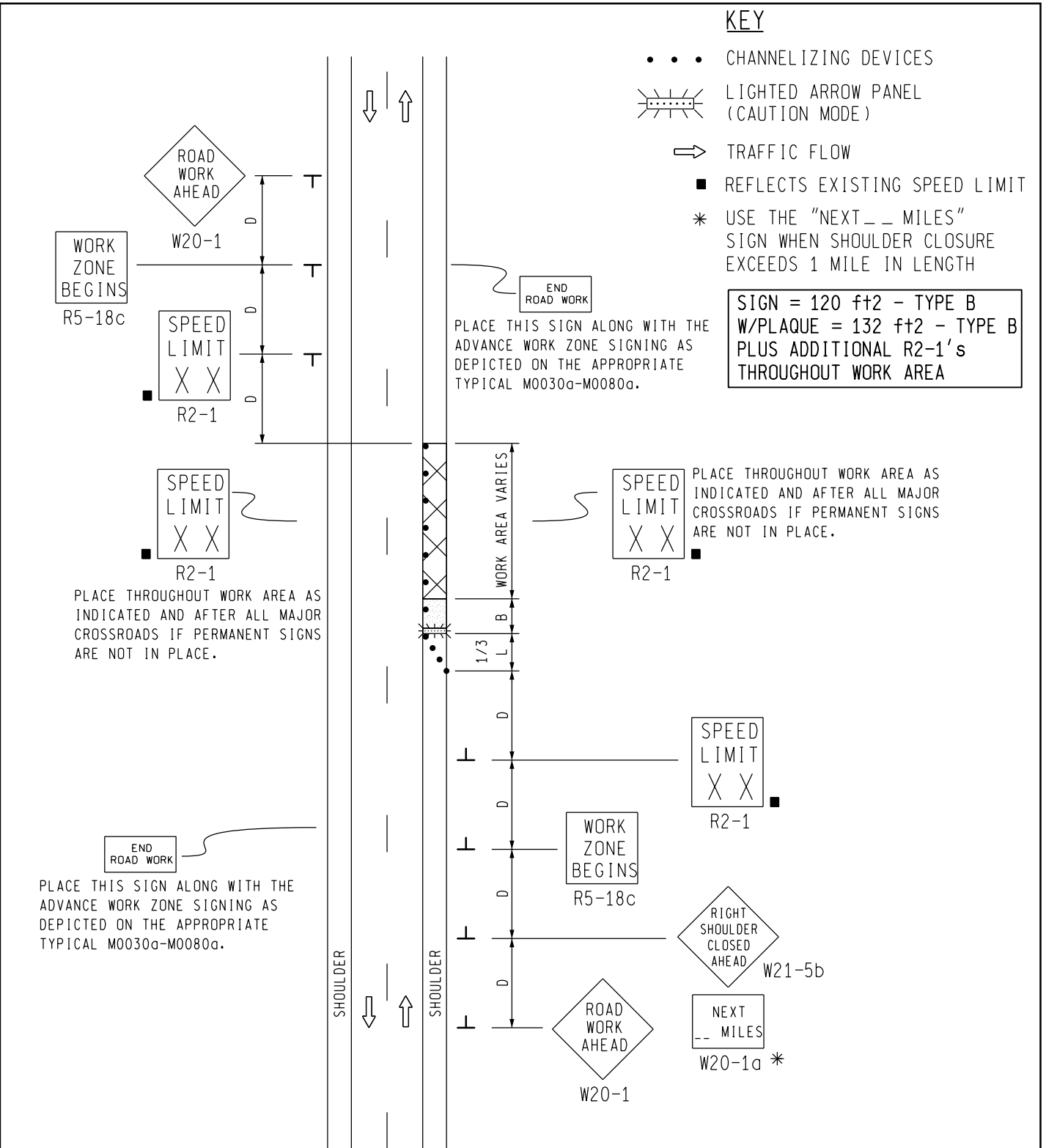

 Michigan Department of Transportation TRAFFIC AND SAFETY MAINTAINING TRAFFIC TYPICAL	TYPICAL TEMPORARY TRAFFIC CONTROL FOR A SHOULDER CLOSURE ON A TWO LANE TWO-WAY ROADWAY NO SPEED REDUCTION	
	DRAWN BY: CON:AE:djf CHECKED: DS-32 BMM:CRB	OCTOBER 2011 PLAN DATE:
FILE: PW RD/TS/Typicals/Signs/MT NON FWY/M0110a.dgn REV. 10/04/2011		

NOT TO SCALE

NOTES

1. D = DISTANCE BETWEEN TRAFFIC CONTROL DEVICES
 $1/3 L$ = MINIMUM LENGTH OF TAPER
 B = LENGTH OF LONGITUDINAL BUFFER
 SEE **M0020a** FOR "D," "L," AND "B" VALUES
2. ALL NON-APPLICABLE SIGNING WITHIN THE CIA SHALL BE MODIFIED TO FIT CONDITIONS, COVERED OR REMOVED.
3. DISTANCES BETWEEN SIGNS, THE VALUES FOR WHICH ARE SHOWN IN TABLE D, ARE APPROXIMATE AND MAY NEED ADJUSTING AS DIRECTED BY THE ENGINEER.
- 3A. THE "WORK ZONE BEGINS" (R5-18c) SIGN SHALL BE USED ONLY IN THE INITIAL SIGNING SEQUENCE IN THE WORK ZONE. SUBSEQUENT SEQUENCES IN THE SAME WORK ZONE SHALL OMIT THIS SIGN AND THE QUANTITIES SHALL BE ADJUSTED APPROPRIATELY.
- 4E. THE MAXIMUM RECOMMENDED DISTANCE(S) BETWEEN CHANNELIZING DEVICES SHOULD BE EQUAL IN FEET TO THE POSTED SPEED IN MILES PER HOUR ON TAPER(S) AND TWICE THE POSTED SPEED IN THE PARALLEL AREA(S).
5. FOR OVERNIGHT CLOSURES, TYPE III BARRICADES SHALL BE LIGHTED.
6. WHEN CALLED FOR IN THE FHWA ACCEPTANCE LETTER FOR THE SIGN SYSTEM SELECTED, THE TYPE A WARNING FLASHER, SHOWN ON THE WARNING SIGNS, SHALL BE POSITIONED ON THE SIDE OF THE SIGN NEAREST THE ROADWAY.
7. ALL TEMPORARY SIGNS, TYPE III BARRICADES, THEIR SUPPORT SYSTEMS AND LIGHTING REQUIREMENTS SHALL MEET NCHRP 350 CRASHWORTHLY REQUIREMENTS STIPULATED IN THE CURRENT EDITION OF THE MICHIGAN MANUAL ON UNIFORM TRAFFIC CONTROL DEVICES, THE CURRENT EDITION OF THE STANDARD SPECIFICATIONS FOR CONSTRUCTION, THE STANDARD PLANS AND APPLICABLE SPECIAL PROVISIONS. ONLY DESIGNS AND MATERIALS APPROVED BY MDOT WILL BE ALLOWED.
8. WHEN BUFFER AREAS ARE ESTABLISHED, THERE SHALL BE NO EQUIPMENT OR MATERIALS STORED OR WORK CONDUCTED IN THE BUFFER AREA.
- 29A. THE TYPE OF REFLECTIVE SHEETING USED FOR THE W20-1a PLAQUE SHALL BE THE SAME AS THE TYPE USED FOR THE PARENT SIGN.

SIGN SIZES

DIAMOND WARNING	- 48" x 48"
W20-1a PLAQUE	- 48" x 36"
R2-1 REGULATORY	- 48" x 60"
R5-18c REGULATORY	- 48" x 48"

NOT TO SCALE

 TRAFFIC AND SAFETY MAINTAINING TRAFFIC TYPICAL	TYPICAL TEMPORARY TRAFFIC CONTROL FOR A SHOULDER CLOSURE ON A TWO LANE TWO-WAY ROADWAY NO SPEED REDUCTION	
	DRAWN BY: CON:AE:djf CHECKED BY: BMM:CRB DS-33	OCTOBER 2011 PLAN DATE:
FILE: PW RD/TS/Typicals/Signs/MT NON FWY/M0110a.dgn REV. 10/04/2011		





PLACE THROUGHOUT WORK AREA AS INDICATED AND AFTER ALL MAJOR CROSSROADS IF PERMANENT SIGNS ARE NOT IN PLACE.

PLACE THIS SIGN ALONG WITH THE ADVANCE WORK ZONE SIGNING AS DEPICTED ON THE APPROPRIATE TYPICAL M0030a-M0080a.

PLACE THROUGHOUT WORK AREA AS INDICATED AND AFTER ALL MAJOR CROSSROADS IF PERMANENT SIGNS ARE NOT IN PLACE.

PLACE THIS SIGN ALONG WITH THE ADVANCE WORK ZONE SIGNING AS DEPICTED ON THE APPROPRIATE TYPICAL M0030a-M0080a.

KEY

-  TRAFFIC REGULATOR
-  CHANNELIZING DEVICES
-  LIGHTED ARROW PANEL (CAUTION MODE)
-  TRAFFIC FLOW
-  REFLECTS EXISTING SPEED LIMIT

SIGN = 200 ft± - TYPE B PLUS ADDITIONAL R2-1's THROUGHOUT WORK AREA

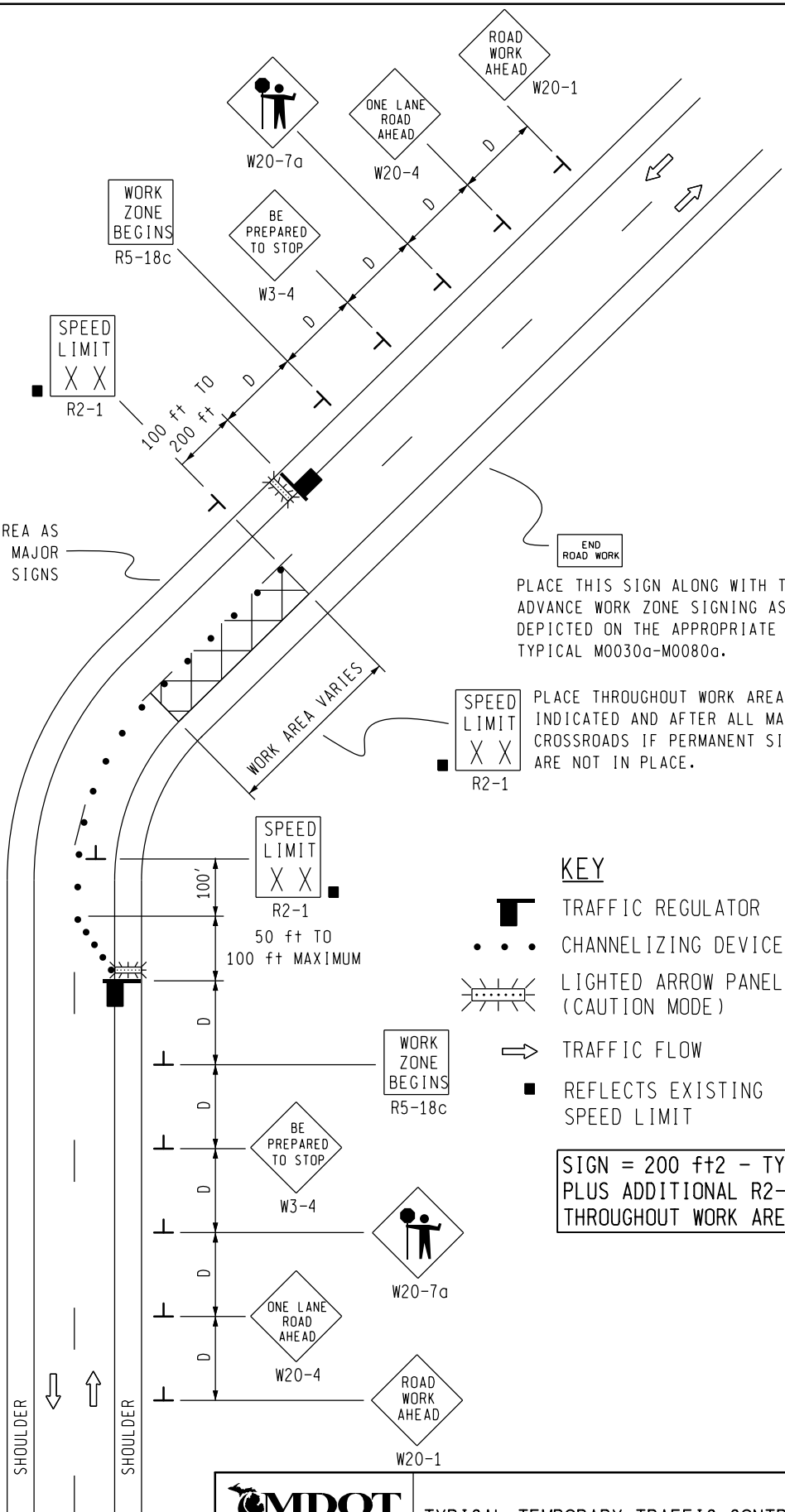

TRAFFIC AND SAFETY
MAINTAINING TRAFFIC
TYPICAL

TYPICAL TEMPORARY TRAFFIC CONTROL FOR A TWO-LANE TWO-WAY ROADWAY WHERE ONE LANE IS CLOSED UTILIZING TRAFFIC REGULATORS, NO SPEED REDUCTION

DRAWN BY: CON:AE:djf
CHECKED BY: BMM:CRB
DS-34

OCTOBER 2011
PLAN DATE:

M0140a

SHEET 1 OF 2

NOT TO SCALE

NOTES

- 1H. D = DISTANCE BETWEEN TRAFFIC CONTROL DEVICES AND LENGTH OF LONGITUDINAL BUFFERS
SEE **M0020a** FOR "D" VALUES.
2. ALL NON-APPLICABLE SIGNING WITHIN THE CIA SHALL BE MODIFIED TO FIT CONDITIONS, COVERED OR REMOVED.
3. DISTANCES BETWEEN SIGNS, THE VALUES FOR WHICH ARE SHOWN IN TABLE D, ARE APPROXIMATE AND MAY NEED ADJUSTING AS DIRECTED BY THE ENGINEER.
- 3A. THE "WORK ZONE BEGINS" (R5-18c) SIGN SHALL BE USED ONLY IN THE INITIAL SIGNING SEQUENCE IN THE WORK ZONE. SUBSEQUENT SEQUENCES IN THE SAME WORK ZONE SHALL OMIT THIS SIGN AND THE QUANTITIES SHALL BE ADJUSTED APPROPRIATELY.
- 4A. THE MAXIMUM RECOMMENDED DISTANCE(S) BETWEEN CHANNELIZING DEVICES IN THE TAPER AREA(S) SHOULD BE 15 FEET AND SHOULD BE EQUAL IN FEET TO TWICE THE POSTED SPEED IN MILES PER HOUR IN THE PARALLEL AREA(S).
5. FOR OVERNIGHT CLOSURES, TYPE III BARRICADES SHALL BE LIGHTED.
6. WHEN CALLED FOR IN THE FHWA ACCEPTANCE LETTER FOR THE SIGN SYSTEM SELECTED, THE TYPE A WARNING FLASHER, SHOWN ON THE WARNING SIGNS, SHALL BE POSITIONED ON THE SIDE OF THE SIGN NEAREST THE ROADWAY.
7. ALL TEMPORARY SIGNS, TYPE III BARRICADES, THEIR SUPPORT SYSTEMS AND LIGHTING REQUIREMENTS SHALL MEET NCHRP 350 CRASHWORTHLY REQUIREMENTS STIPULATED IN THE CURRENT EDITION OF THE MICHIGAN MANUAL ON UNIFORM TRAFFIC CONTROL DEVICES, THE CURRENT EDITION OF THE STANDARD SPECIFICATIONS FOR CONSTRUCTION, THE STANDARD PLANS AND APPLICABLE SPECIAL PROVISIONS. ONLY DESIGNS AND MATERIALS APPROVED BY MDOT WILL BE ALLOWED.
9. ALL TRAFFIC REGULATORS SHALL BE PROPERLY TRAINED AND SUPERVISED.
- 9A. IN ANY OPERATION INVOLVING MORE THAN ONE TRAFFIC REGULATOR, ONE PERSON SHOULD BE DESIGNATED AS HEAD TRAFFIC REGULATOR.
10. ALL TRAFFIC REGULATORS' CONDUCT, THEIR EQUIPMENT, AND TRAFFIC REGULATING PROCEDURES SHALL CONFORM TO THE CURRENT EDITION OF THE MICHIGAN MANUAL OF UNIFORM TRAFFIC CONTROL DEVICES (MMUTCD) AND THE CURRENT EDITION OF THE MDOT HANDBOOK ENTITLED "TRAFFIC REGULATORS INSTRUCTION MANUAL."
11. WHEN TRAFFIC REGULATING IS ALLOWED DURING THE HOURS OF DARKNESS, APPROPRIATE LIGHTING SHALL BE PROVIDED TO SUFFICIENTLY ILLUMINATE THE TRAFFIC REGULATOR'S STATIONS.
- 12E. THE MAXIMUM DISTANCE BETWEEN THE TRAFFIC REGULATORS SHALL BE NO MORE THAN 2 MILES IN LENGTH UNLESS RESTRICTED FURTHER IN THE SPECIAL PROVISIONS FOR MAINTAINING TRAFFIC. ALL SEQUENCES OF MORE THAN 2 MILES IN LENGTH WILL REQUIRE WRITTEN PERMISSION FROM THE ENGINEER BEFORE PROCEEDING.
13. WHEN INTERSECTING ROADS OR SIGNIFICANT TRAFFIC GENERATORS (SHOPPING CENTERS, MOBILE HOME PARKS, ETC.) OCCUR WITHIN THE ONE-LANE TWO-WAY OPERATION, INTERMEDIATE TRAFFIC REGULATORS AND APPROPRIATE SIGNING SHALL BE PLACED AT THESE LOCATIONS.
14. ADDITIONAL SIGNING AND/OR ELONGATED SIGNING SEQUENCES SHOULD BE USED WHEN TRAFFIC VOLUMES ARE SIGNIFICANT ENOUGH TO CREATE BACKUPS BEYOND THE W3-4 SIGNS.
15. THE HAND HELD (PADDLE) SIGNS REQUIRED BY THE MMUTCD TO CONTROL TRAFFIC WILL BE PAID FOR AS PART OF FLAG CONTROL.
- 28E. THE TRAFFIC REGULATORS SHOULD BE POSITIONED AT OR NEAR THE SIDE OF THE ROAD SO THAT THEY ARE SEEN CLEARLY AT A MINIMUM DISTANCE OF 500 FEET. THIS MAY REQUIRE EXTENDING THE BEGINNING OF THE LANE CLOSURE TO OVERCOME VIEWING PROBLEMS CAUSED BY HILLS AND CURVES.

SIGN SIZES

DIAMOND WARNING - 48" x 48"
 R2-1 REGULATORY - 48" x 60"
 R5-18c REGULATORY - 48" x 48"

NOT TO SCALE

 Michigan Department of Transportation TRAFFIC AND SAFETY MAINTAINING TRAFFIC TYPICAL	TYPICAL TEMPORARY TRAFFIC CONTROL FOR A TWO-LANE TWO-WAY ROADWAY WHERE ONE LANE IS CLOSED UTILIZING TRAFFIC REGULATORS, NO SPEED REDUCTION		
DRAWN BY: CON:AE:djf	OCTOBER 2011	M0140a	
CHECKED BY: BMM:CRB	PLAN DATE:		
FILE: PW RD/TS/Typicals/Signs/MT NON FWY/M0140a.dgn REV. 10/04/2011			

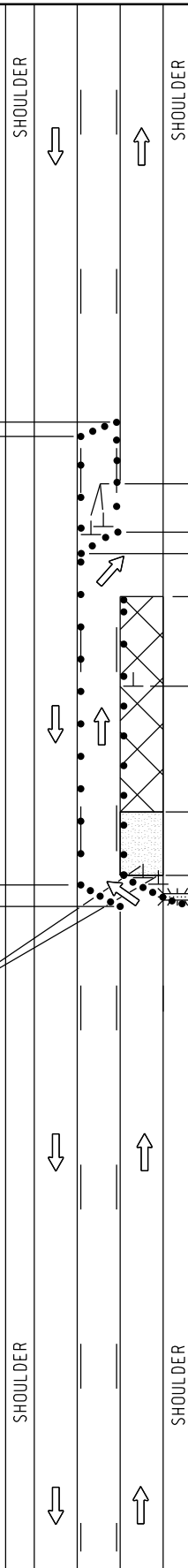
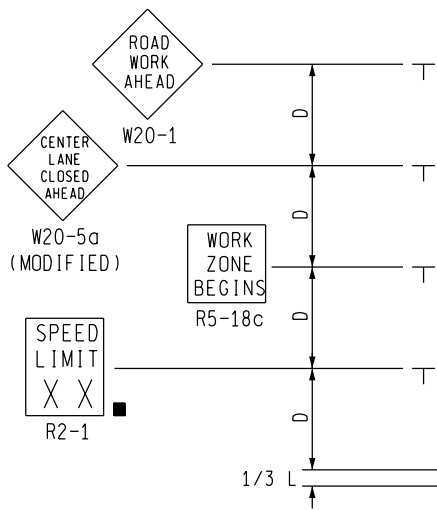

END ROAD WORK

PLACE THIS SIGN ALONG WITH THE ADVANCE WORK ZONE SIGNING AS DEPICTED ON THE APPROPRIATE TYPICAL M0030a-M0050a.

SPEED LIMIT XX R2-1

PLACE THROUGHOUT WORK AREA AS INDICATED AND AFTER ALL MAJOR CROSSROADS IF PERMANENT SIGNS ARE NOT IN PLACE.

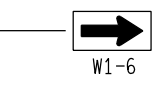

1/2 L
1/2 D

D

WORK AREA VARIES



W1-4

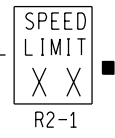

R2-1

PLACE THROUGHOUT WORK AREA AS INDICATED AND AFTER ALL MAJOR CROSSROADS IF PERMANENT SIGNS ARE NOT IN PLACE.

1/2 L



W1-6

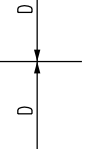

R2-1



R5-18c



W1-4

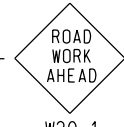

W20-1

END ROAD WORK

PLACE THIS SIGN ALONG WITH THE ADVANCE WORK ZONE SIGNING AS DEPICTED ON THE APPROPRIATE TYPICAL M0030a-M0050a.

KEY

- • • CHANNELIZING DEVICES
- ⚡ LIGHTED ARROW PANEL (CAUTION MODE)
- ➡ TRAFFIC FLOW
- REFLECTS EXISTING SPEED LIMIT

SIGN = 184 ft± - TYPE B PLUS ADDITIONAL R2-1's THROUGHOUT WORK AREA

NOT TO SCALE

MDOT
Michigan Department of Transportation

TRAFFIC AND SAFETY
MAINTAINING TRAFFIC
TYPICAL

DS-36

DRAWN BY: CON:AE:DJF
CHECKED BY: BMM:CRB

TYPICAL TEMPORARY TRAFFIC CONTROL FOR CLOSING ONE LANE OF A THREE LANE ROADWAY WITH CLFLT0 AND SHIFTING ONE THROUGH LANE INTO THE CLFLT0 NO SPEED REDUCTION

OCTOBER 2011
PLAN DATE:

M0231a

SHEET 1 OF 2

FILE: PW: RD/T&S/Typicals/Signs/MT/MT nonFwy/M0231a REV. 10/18/2011

NOTES

- 1F. D = DISTANCE BETWEEN TRAFFIC CONTROL DEVICES
 $1/2 L$, AND $1/3 L$ = MINIMUM LENGTH OF TAPER
 B = LENGTH OF LONGITUDINAL BUFFER
 SEE M0020a FOR "D," "L," AND "B" VALUES
2. ALL NON-APPLICABLE SIGNING WITHIN THE CIA SHALL BE MODIFIED TO FIT CONDITIONS, COVERED OR REMOVED.
3. DISTANCES BETWEEN SIGNS, THE VALUES FOR WHICH ARE SHOWN IN TABLE D, ARE APPROXIMATE AND MAY NEED ADJUSTING AS DIRECTED BY THE ENGINEER.
- 3A. THE "WORK ZONE BEGINS" (R5-18c) SIGN SHALL BE USED ONLY IN THE INITIAL SIGNING SEQUENCE IN THE WORK ZONE. SUBSEQUENT SEQUENCES IN THE SAME WORK ZONE SHALL OMIT THIS SIGN AND THE QUANTITIES SHALL BE ADJUSTED APPROPRIATELY.
- 4E. THE MAXIMUM RECOMMENDED DISTANCE(S) BETWEEN CHANNELIZING DEVICES SHOULD BE EQUAL IN FEET TO THE POSTED SPEED IN MILES PER HOUR ON TAPER(S) AND TWICE THE POSTED SPEED IN THE PARALLEL AREA(S).
5. FOR OVERNIGHT CLOSURES, TYPE III BARRICADES SHALL BE LIGHTED.
6. THE TYPE A WARNING FLASHER SHOWN ON THE WARNING SIGNS SHALL BE POSITIONED ON THE SIDE OF THE SIGN NEAREST THE ROADWAY.
7. ALL TEMPORARY SIGNS, TYPE III BARRICADES, THEIR SUPPORT SYSTEMS AND LIGHTING REQUIREMENTS SHALL MEET NCHRP 350 CRASHWORTHY REQUIREMENTS STIPULATED IN THE CURRENT EDITION OF THE MICHIGAN MANUAL ON UNIFORM TRAFFIC CONTROL DEVICES, THE CURRENT EDITION OF THE STANDARD SPECIFICATIONS FOR CONSTRUCTION, THE STANDARD PLANS AND APPLICABLE SPECIAL PROVISIONS. ONLY DESIGNS AND MATERIALS APPROVED BY MDOT WILL BE ALLOWED.
8. WHEN BUFFER AREAS ARE ESTABLISHED, THERE SHALL BE NO EQUIPMENT OR MATERIALS STORED OR WORK CONDUCTED IN THE BUFFER AREA.
21. ALL EXISTING PAVEMENT MARKINGS WHICH ARE IN CONFLICT WITH EITHER PROPOSED CHANGES IN TRAFFIC PATTERNS OR PROPOSED TEMPORARY TRAFFIC MARKINGS, SHALL BE REMOVED BEFORE ANY CHANGE IS MADE IN THE TRAFFIC PATTERN. EXCEPTION WILL BE MADE FOR DAYTIME-ONLY TRAFFIC PATTERNS THAT ARE ADEQUATELY DELINEATED BY OTHER TRAFFIC CONTROL DEVICES.

SIGN SIZES

DIAMOND WARNING	- 48" x 48"
W1-6 WARNING	- 48" x 24"
R2-1 REGULATORY	- 48" x 60"
R5-18c REGULATORY	- 48" x 48"

NOT TO SCALE

 MDOT Michigan Department of Transportation TRAFFIC AND SAFETY MAINTAINING TRAFFIC TYPICAL	TYPICAL TEMPORARY TRAFFIC CONTROL FOR CLOSING ONE LANE OF A THREE LANE ROADWAY WITH CLFLTO AND SHIFTING ONE THROUGH LANE INTO THE CLFLTO NO SPEED REDUCTION		
DRAWN BY: CON:AE:DJF CHECKED BY: DS-37 BMM:CRB	OCTOBER 2011 PLAN DATE:	M0231a	SHEET 2 OF 2
FILE: PW: RD/T&S/Typicals/Signs/MT/MT nonFwy/M0231a REV. 10/18/2011			

KEY

- • • CHANNELIZING DEVICES
- ⚡ LIGHTED ARROW PANEL
- ➡ TRAFFIC FLOW
- REFLECTS EXISTING SPEED LIMIT

SIGN = 136 ft±2 - TYPE B PLUS ADDITIONAL R2-1's THROUGHOUT WORK AREA

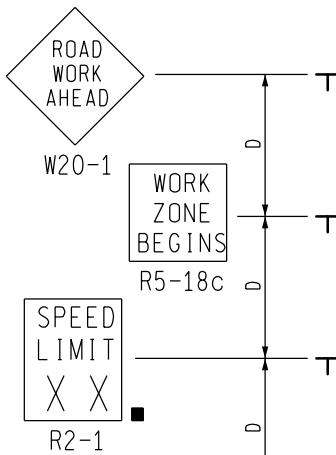

END ROAD WORK
PLACE THIS SIGN ALONG WITH THE ADVANCE WORK ZONE SIGNING AS DEPICTED ON THE APPROPRIATE TYPICAL M0030a-M0080a.



PLACE THROUGHOUT WORK AREA AS INDICATED AND AFTER ALL MAJOR CROSSROADS IF PERMANENT SIGNS ARE NOT IN PLACE.

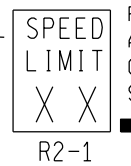

PLACE THROUGHOUT WORK AREA AS INDICATED AND AFTER ALL CROSSROADS IF PERMANENT SIGNS ARE NOT IN PLACE.

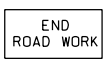

PLACE THIS SIGN ALONG WITH THE ADVANCE WORK ZONE SIGNING AS DEPICTED ON THE APPROPRIATE TYPICAL M0030a-M0080a.

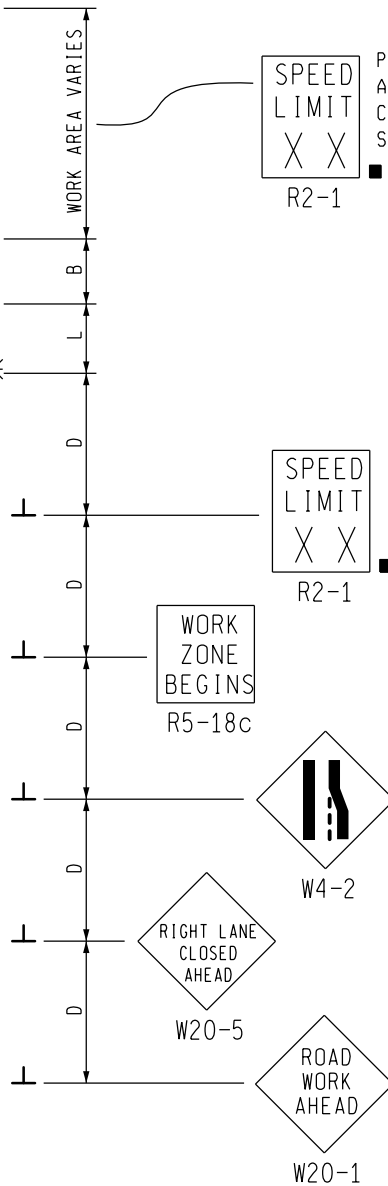
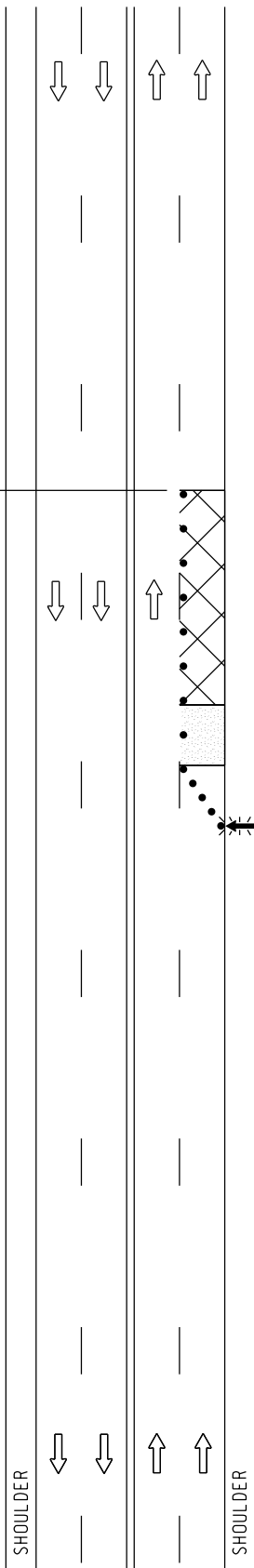

MDOT
Michigan Department of Transportation
TRAFFIC AND SAFETY
MAINTAINING TRAFFIC
TYPICAL

TYPICAL TEMPORARY TRAFFIC CONTROL
FOR A ONE-LANE CLOSURE ON AN
UNDIVIDED MULTI-LANE ROADWAY,
NO SPEED REDUCTION

DRAWN BY: CON:AE:djf
CHECKED BY: BMM:CRB

OCTOBER 2011
PLAN DATE:

M0240a

SHEET
1 OF 2

NOT TO SCALE

NOTES

- 1B. D = DISTANCE BETWEEN TRAFFIC CONTROL DEVICES
L = MINIMUM LENGTH OF TAPER
B = LENGTH OF LONGITUDINAL BUFFER
SEE **M0020a** FOR "D," "L," AND "B" VALUES
2. ALL NON-APPLICABLE SIGNING WITHIN THE CIA SHALL BE MODIFIED TO FIT CONDITIONS, COVERED OR REMOVED.
3. DISTANCES BETWEEN SIGNS, THE VALUES FOR WHICH ARE SHOWN IN TABLE D, ARE APPROXIMATE AND MAY NEED ADJUSTING AS DIRECTED BY THE ENGINEER.
- 3A. THE "WORK ZONE BEGINS" (R5-18c) SIGN SHALL BE USED ONLY IN THE INITIAL SIGNING SEQUENCE IN THE WORK ZONE. SUBSEQUENT SEQUENCES IN THE SAME WORK ZONE SHALL OMIT THIS SIGN AND THE QUANTITIES SHALL BE ADJUSTED APPROPRIATELY.
- 4E. THE MAXIMUM RECOMMENDED DISTANCE(S) BETWEEN CHANNELIZING DEVICES SHOULD BE EQUAL IN FEET TO THE POSTED SPEED IN MILES PER HOUR ON TAPER(S) AND TWICE THE POSTED SPEED IN THE PARALLEL AREA(S).
5. FOR OVERNIGHT CLOSURES, TYPE III BARRICADES SHALL BE LIGHTED.
6. WHEN CALLED FOR IN THE FHWA ACCEPTANCE LETTER FOR THE SIGN SYSTEM SELECTED, THE TYPE A WARNING FLASHER, SHOWN ON THE WARNING SIGNS, SHALL BE POSITIONED ON THE SIDE OF THE SIGN NEAREST THE ROADWAY.
7. ALL TEMPORARY SIGNS, TYPE III BARRICADES, THEIR SUPPORT SYSTEMS AND LIGHTING REQUIREMENTS SHALL MEET NCHRP 350 CRASHWORTHLY REQUIREMENTS STIPULATED IN THE CURRENT EDITION OF THE MICHIGAN MANUAL ON UNIFORM TRAFFIC CONTROL DEVICES, THE CURRENT EDITION OF THE STANDARD SPECIFICATIONS FOR CONSTRUCTION, THE STANDARD PLANS AND APPLICABLE SPECIAL PROVISIONS. ONLY DESIGNS AND MATERIALS APPROVED BY MDOT WILL BE ALLOWED.
8. WHEN BUFFER AREAS ARE ESTABLISHED, THERE SHALL BE NO EQUIPMENT OR MATERIALS STORED OR WORK CONDUCTED IN THE BUFFER AREA.
21. ALL EXISTING PAVEMENT MARKINGS WHICH ARE IN CONFLICT WITH EITHER PROPOSED CHANGES IN TRAFFIC PATTERNS OR PROPOSED TEMPORARY TRAFFIC MARKINGS, SHALL BE REMOVED BEFORE ANY CHANGE IS MADE IN THE TRAFFIC PATTERN. EXCEPTION WILL BE MADE FOR DAYTIME-ONLY TRAFFIC PATTERNS THAT ARE ADEQUATELY DELINEATED BY OTHER TRAFFIC CONTROL DEVICES.
26. THE LIGHTED ARROW PANEL SHALL BE LOCATED AT THE BEGINNING OF THE TAPER AS SHOWN. WHEN PHYSICAL LIMITATIONS RESTRICT ITS PLACEMENT AS INDICATED, THEN IT SHALL BE PLACED AS CLOSE TO THE BEGINNING OF THE TAPER AS POSSIBLE.

SIGN SIZES

DIAMOND WARNING - 48" x 48"
R2-1 REGULATORY - 48" x 60"
R5-18c REGULATORY - 48" x 48"

NOT TO SCALE

 MDOT Michigan Department of Transportation TRAFFIC AND SAFETY MAINTAINING TRAFFIC TYPICAL	TYPICAL TEMPORARY TRAFFIC CONTROL FOR A ONE-LANE CLOSURE ON AN UNDIVIDED MULTI-LANE ROADWAY, NO SPEED REDUCTION
DRAWN BY: CON:AE:djf CHECKED: DS-39 BMM:CRB	OCTOBER 2011 PLAN DATE:
FILE: PW RD/TS/Typicals/Signs/MT NON FWY/M0240a.dgn REV. 10/11/2011	M0240a SHEET 2 OF 2

SIGN MATERIAL SELECTION TABLE

SIGN SIZE	SIGN MATERIAL TYPE		
	TYPE I	TYPE II	TYPE III
≤ 36" X 36"		X	X
>36" X 36" ≤ 96" TO WIDE		X	
> 96" WIDE TO 144" WIDE	X	X	
> 144" WIDE	X		

TYPE I ALUMINUM EXTRUSION
 TYPE II PLYWOOD
 TYPE III ALUMINUM SHEET

ROUNDING OF CORNERS IS NOT REQUIRED FOR TYPE I OR II SIGNS.
 VERTICAL JOINTS ARE NOT PERMITTED.
 HORIZONTAL JOINTS THROUGH SIGN LEGEND OR SYMBOLS ARE NOT PERMITTED.

POST SIZE REQUIREMENTS TABLE

SIGN AREA (ft ²)	POST TYPE		
	U-CHANNEL STEEL	SQUARE TUBULAR STEEL	WOOD
≤ 9	1 - 3 lb/ft*	1 - 2" 12 or 14 GA*	N/A
9 ≤ 20	2 - 3 lb/ft	2 - 2" 12 or 14 GA	1 - 4" X 6"*
> 20 ≤ 30	N/A	N/A	2 - 4" X 6"
> 30 ≤ 60	N/A	N/A	2 - 6" X 8"
> 60 ≤ 84	N/A	N/A	3 - 6" X 8"

*SIGNS 4 FEET AND GREATER IN WIDTH REQUIRE 2 POSTS.
 SIGNS GREATER THAN 8 FEET IN WIDTH REQUIRE 2 OR 3 WOOD
 POSTS DEPENDING ON AREA OF SIGN.
 A MAXIMUM OF 2 POSTS WITHIN A 7' PATH IS PERMITTED.

 PREPARED BY DESIGN DIVISION	DEPARTMENT DIRECTOR Kirk T. Steudle APPROVED BY: _____ DIRECTOR, BUREAU OF FIELD SERVICES	MICHIGAN DEPARTMENT OF TRANSPORTATION BUREAU OF DEVELOPMENT STANDARD PLAN FOR GROUND DRIVEN SIGN SUPPORTS FOR TEMP SIGNS		
	DRAWN BY: CON/ECH CHECKED BY: AUG	APPROVED BY: _____ DIRECTOR, BUREAU OF DEVELOPMENT	_____ F.H.W.A. APPROVAL	11/2/2017 PLAN DATE

2 POST SIGN SUPPORT SPACING

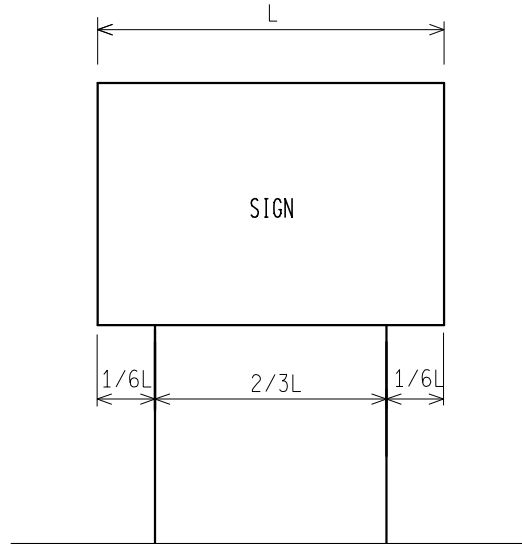

3 POST SIGN SUPPORT SPACING

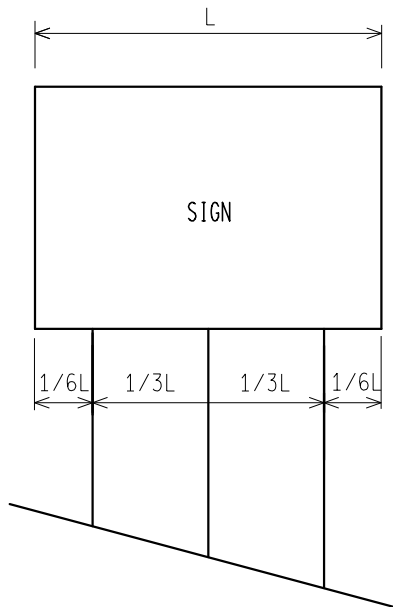

* FOR ALL 11' AND 12' LONG SIGNS ON 3 WOOD SUPPORTS, SPREAD POSTS SO AS TO HAVE A 8' MIN. TO 9' MAX. DISTANCE BETWEEN OUTSIDE POSTS.

NOT TO SCALE

MICHIGAN DEPARTMENT OF TRANSPORTATION
BUREAU OF DEVELOPMENT STANDARD PLAN

F.H.W.A. APPROVAL

11/2/2017
PLAN DATE

WZD-100-A

SHEET
2 OF 11

NOTE: THE ORIGINAL SIGNED COPY IS KEPT ON FILE AT THE MICHIGAN DEPARTMENT OF TRANSPORTATION.

DS-41

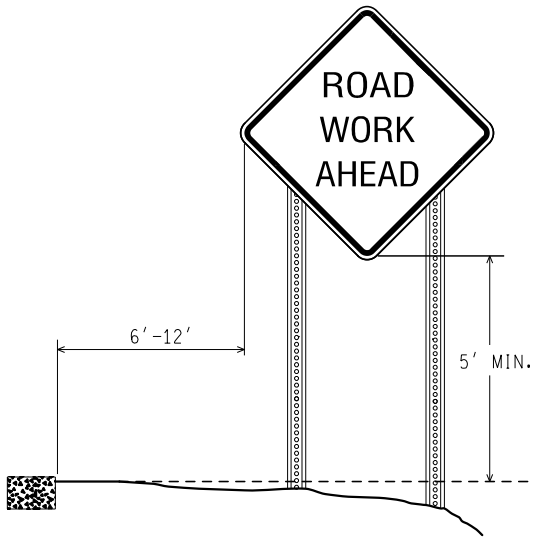

RURAL

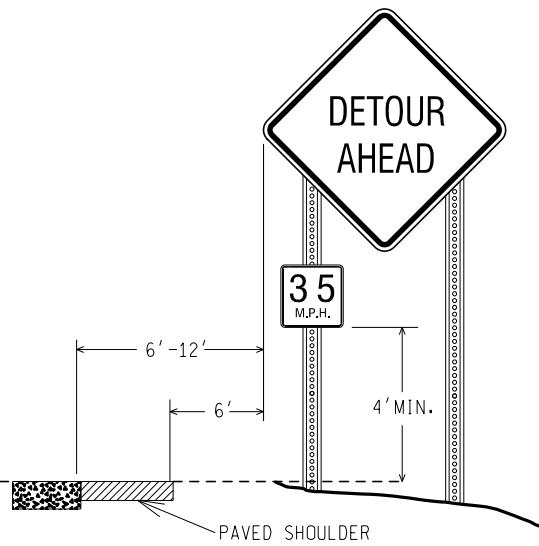

RURAL WITH ADVISORY SPEED PLATE

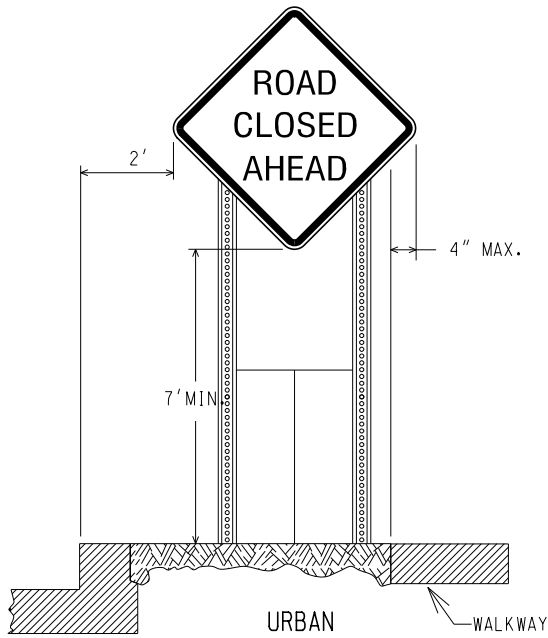

URBAN

(CURBED AREAS OR WHERE WALKWAYS ARE PRESENT)

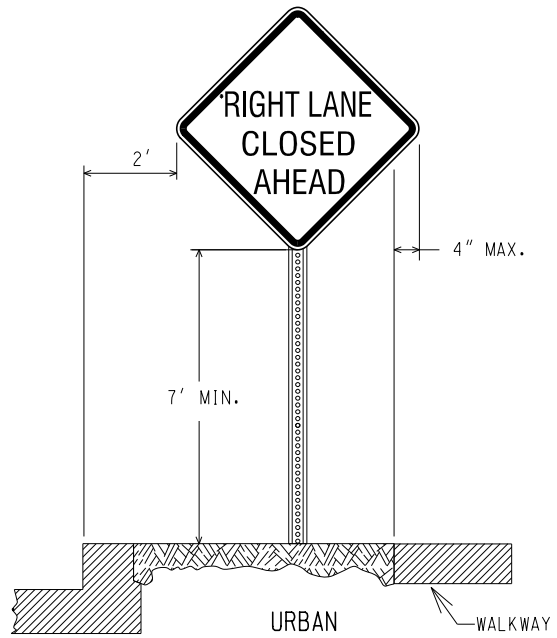

URBAN

(CURBED AREAS OR WHERE WALKWAYS ARE PRESENT)

BOTTOM HEIGHT AND OFFSET

NOT TO SCALE

MICHIGAN DEPARTMENT OF TRANSPORTATION
BUREAU OF DEVELOPMENT STANDARD PLAN

F.H.W.A. APPROVAL

11/2/2017
PLAN DATE

WZD-100-A

SHEET
3 OF 11

NOTE: THE ORIGINAL SIGNED COPY IS KEPT ON FILE AT THE MICHIGAN DEPARTMENT OF TRANSPORTATION.

DS-42

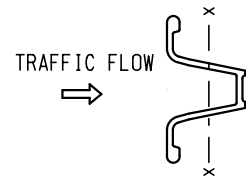
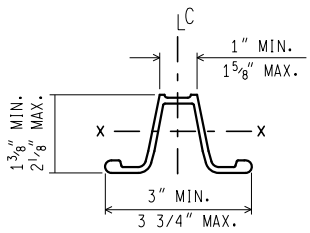
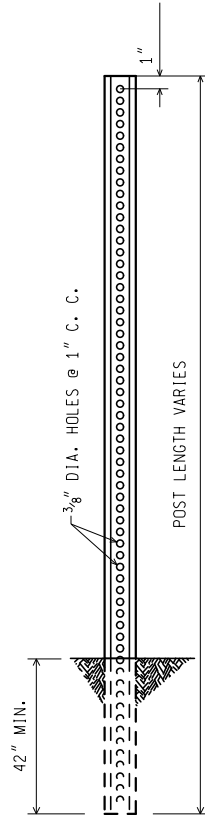

WEIGHT = 3 lbs/ft
 SECT. MOD. X.-X. = 0.31 CUBIC INCHES MIN.

3 lb. U - CHANNEL STEEL POST
 (NO SPLICE)

MOUNT SIGN ON OPEN FACE OF
 U - CHANNEL STEEL POST

NOT TO SCALE

MICHIGAN DEPARTMENT OF TRANSPORTATION BUREAU OF DEVELOPMENT STANDARD PLAN	F.H.W.A. APPROVAL	11/2/2017 PLAN DATE	WZD-100-A	SHEET 4 OF 11
--	-------------------	------------------------	-----------	------------------

NOTE: THE ORIGINAL SIGNED COPY IS KEPT ON FILE AT THE MICHIGAN DEPARTMENT OF TRANSPORTATION.

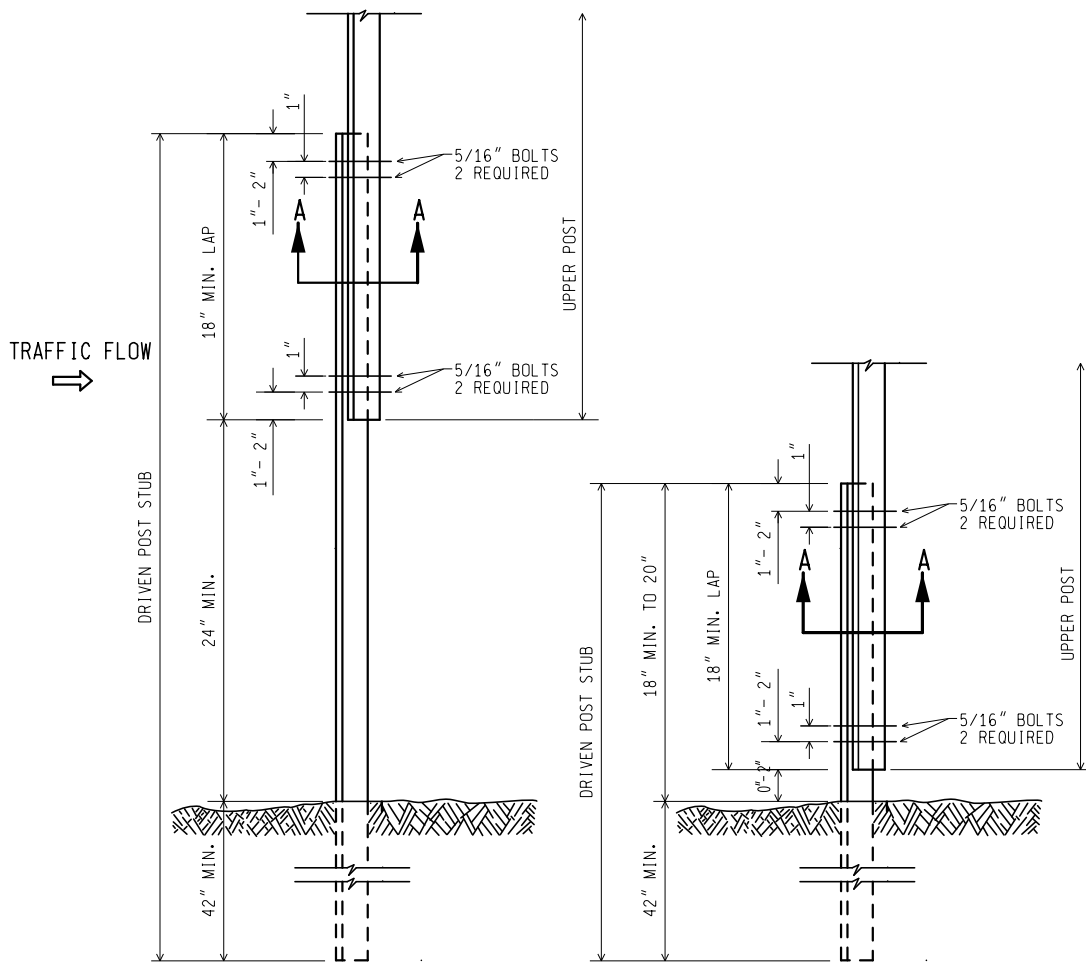

3 lb. U - CHANNEL STEEL POST
(WITH SPLICE)

MOUNT SIGN ON OPEN FACE OF
UPPER U - CHANNEL STEEL POST

NOT TO SCALE

MICHIGAN DEPARTMENT OF TRANSPORTATION BUREAU OF DEVELOPMENT STANDARD PLAN	F.H.W.A. APPROVAL	11/2/2017 PLAN DATE	WZD-100-A	SHEET 5 OF 11
--	-------------------	------------------------	-----------	------------------

NOTE: THE ORIGINAL SIGNED COPY IS KEPT ON FILE AT THE MICHIGAN DEPARTMENT OF TRANSPORTATION.

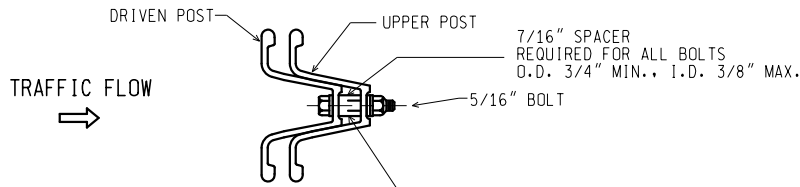

SECTION A-A

7/16" SPACER
 REQUIRED FOR ALL BOLTS
 O.D. 3/4" MIN., I.D. 3/8" MAX.

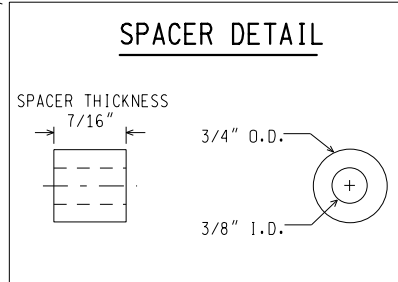

NOTES:

1. THE SPACER THICKNESS SHALL BE 1/16" LESS THAN THE GAP BETWEEN THE POST WHEN POSITIONED IN THE UNBOLTED CONFIGURATION.
2. THE EXTERIOR BOLT (CLOSEST TO LAP), SPACER, WASHER, AND NUT SHALL BE INSTALLED IN A PREPUNCHED HOLE 1" TO 2" FROM THE END OF THE LAP.
3. THE INTERIOR BOLT (FARTHEST FROM LAP), SPACER, WASHER, AND NUT SHALL BE INSTALLED IN THE NEXT PREPUNCHED HOLE.
4. THE DRIVEN POST SHALL ALWAYS BE MOUNTED IN FRONT OF THE UPPER POST WITH RESPECT TO THE ADJACENT ONCOMING TRAFFIC, REGARDLESS OF THE DIRECTION THE SIGN IS FACING.
5. THE SPLICE LAP SHALL BE FASTENED BY FOUR-5/16" DIA. GALVANIZED A449 BOLTS (SAE J429 GRADE 5) OR GALVANIZED A325 BOLTS.

3 lb. U - CHANNEL STEEL POST
 (WITH SPLICE)

NOT TO SCALE

MICHIGAN DEPARTMENT OF TRANSPORTATION BUREAU OF DEVELOPMENT STANDARD PLAN	F.H.W.A. APPROVAL	11/2/2017 PLAN DATE	WZD-100-A	SHEET 6 OF 11
--	-------------------	------------------------	-----------	------------------

NOTE: THE ORIGINAL SIGNED COPY IS KEPT ON FILE AT THE MICHIGAN DEPARTMENT OF TRANSPORTATION.

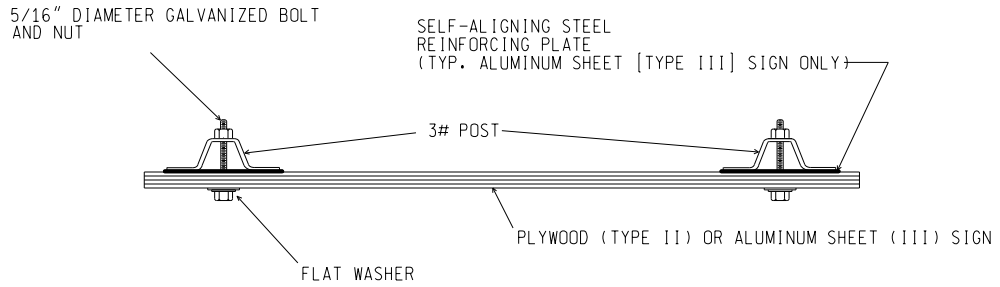

SIGN TO 3 lb. POST CONNECTION

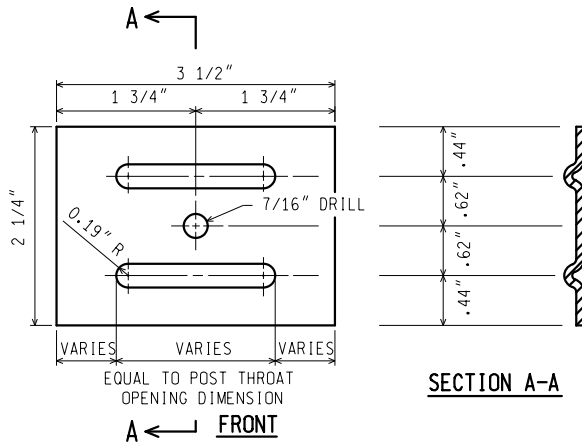

NOTES: (FOR STEEL SIGN REINF' PLATE)

1. MATERIAL: 12 GAUGE CARBON STEEL.
2. TOLERANCE ON ALL DIMENSIONS $\pm 0.0625"$
3. FINISH-AFTER STAMPING AND PUNCHING, GALVANIZE ACCORDING TO CURRENT SPECIFICATIONS FOR ZINC (HOT GALVANIZE) COATINGS ON PRODUCTS FABRICATED FROM PLATES OR STRIPS

STEEL SIGN REINFORCING PLATE
REQUIRED FOR TYPE III SIGNS ONLY

3 lb. U - CHANNEL STEEL POST SIGN CONNECTION

NOT TO SCALE

MICHIGAN DEPARTMENT OF TRANSPORTATION
BUREAU OF DEVELOPMENT STANDARD PLAN

F.H.W.A. APPROVAL

11/2/2017
PLAN DATE

WZD-100-A

SHEET
7 OF 11

NOTE: THE ORIGINAL SIGNED COPY IS KEPT ON FILE AT THE MICHIGAN DEPARTMENT OF TRANSPORTATION.

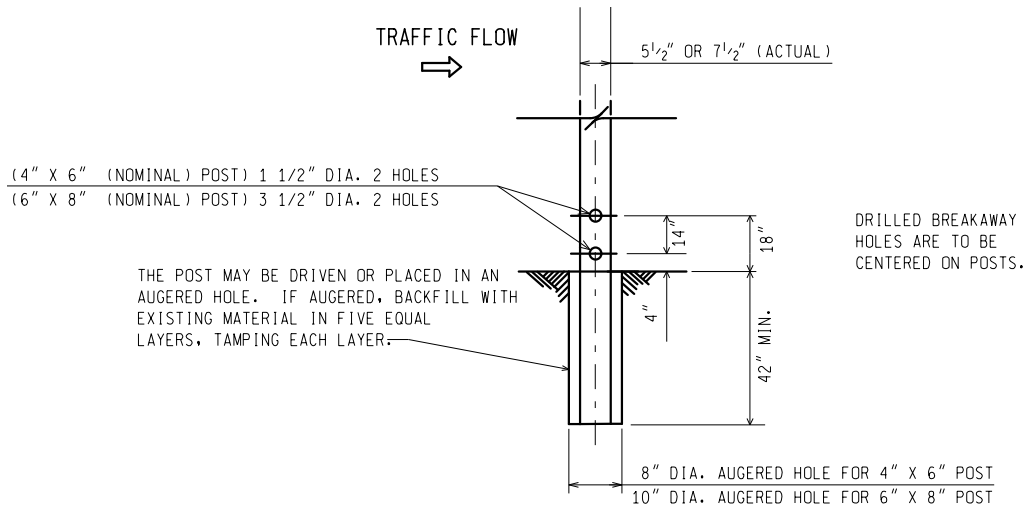

**WOOD POST BREAKAWAY HOLES/
 DIRECT EMBEDMENT DETAILS**

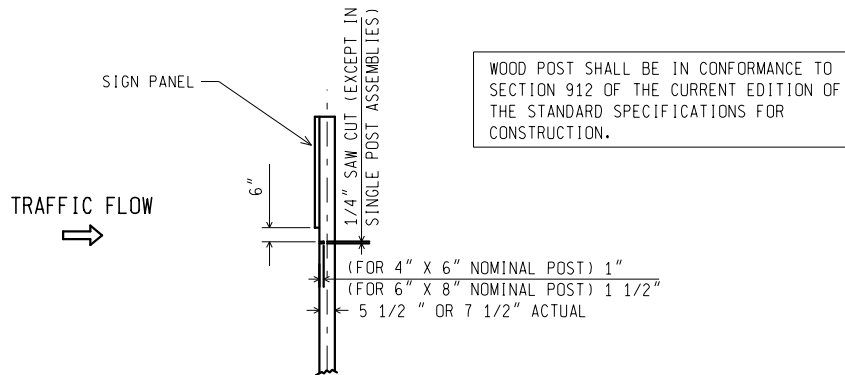

**SAW CUT DETAIL
 (MULTIPLE POST INSTALLATIONS)**

WOOD POST DETAILS

NOT TO SCALE

MICHIGAN DEPARTMENT OF TRANSPORTATION
 BUREAU OF DEVELOPMENT STANDARD PLAN

F.H.W.A. APPROVAL

11/2/2017
 PLAN DATE

WZD-100-A

SHEET
 8 OF 11

NOTE: THE ORIGINAL SIGNED COPY IS KEPT ON FILE AT THE MICHIGAN DEPARTMENT OF TRANSPORTATION.

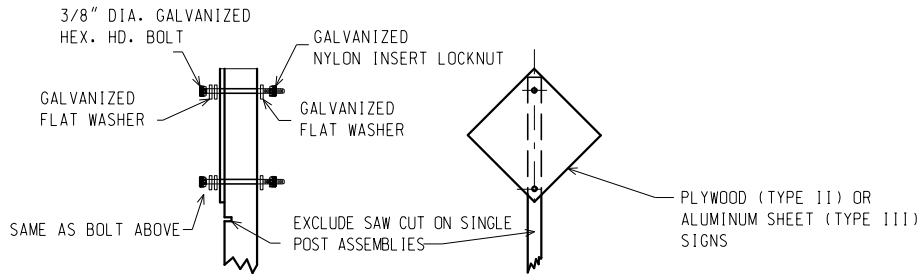

TYPE II AND TYPE III SIGNS

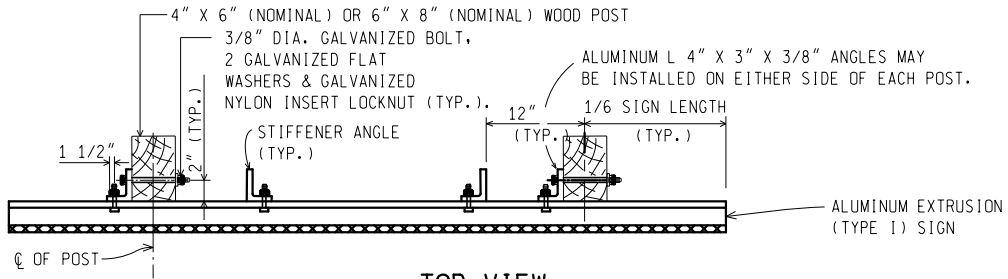

**TOP VIEW
TYPE I SIGN**

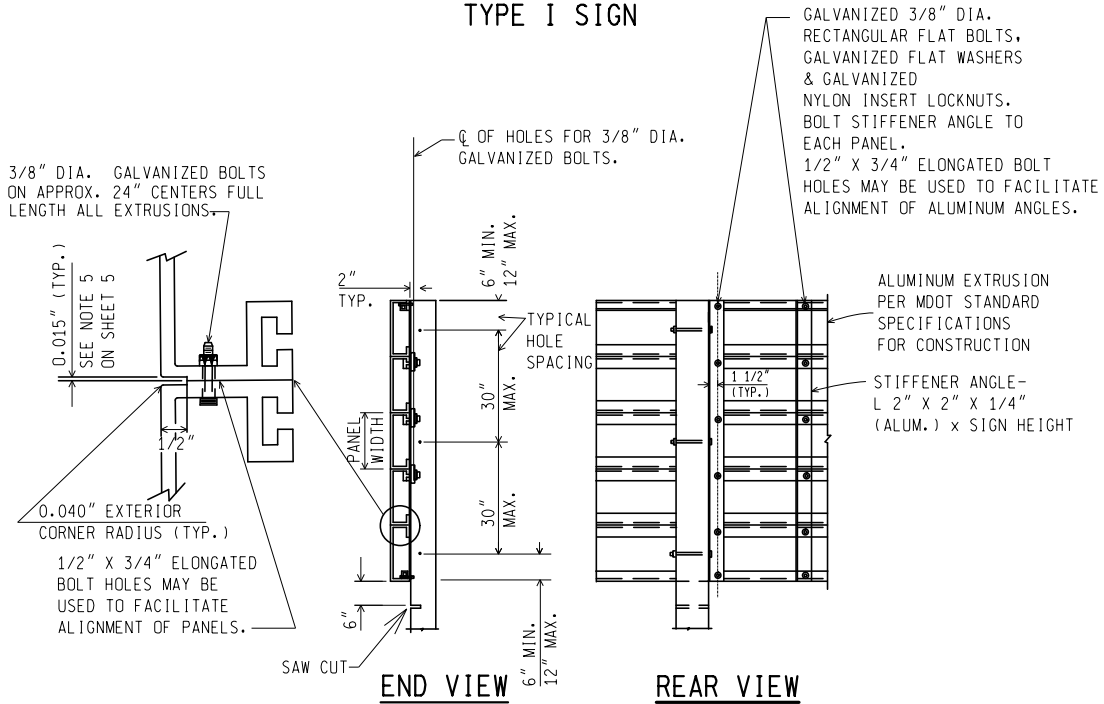

TYPE I SIGN - ERECTION DETAILS

WOOD POST CONNECTIONS

NOT TO SCALE

MICHIGAN DEPARTMENT OF TRANSPORTATION
BUREAU OF DEVELOPMENT STANDARD PLAN

F.H.W.A. APPROVAL

11/2/2017
PLAN DATE

WZD-100-A

SHEET
9 OF 11

NOTE: THE ORIGINAL SIGNED COPY IS KEPT ON FILE AT THE MICHIGAN DEPARTMENT OF TRANSPORTATION.

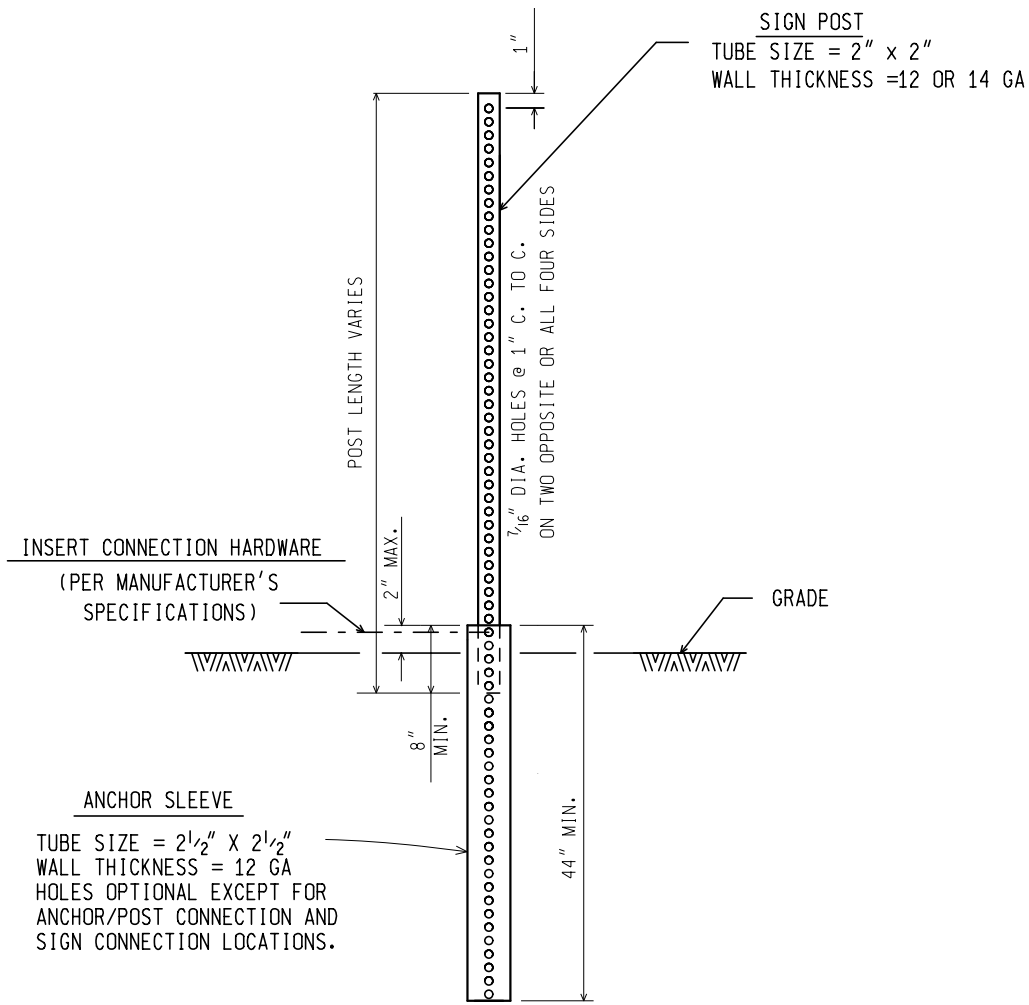

SQUARE TUBULAR STEEL POST

NOT TO SCALE

MICHIGAN DEPARTMENT OF TRANSPORTATION BUREAU OF DEVELOPMENT STANDARD PLAN	F.H.W.A. APPROVAL	11/2/2017 PLAN DATE	WZD-100-A	SHEET 10 OF 11
--	-------------------	------------------------	-----------	-------------------

NOTE: THE ORIGINAL SIGNED COPY IS KEPT ON FILE AT THE MICHIGAN DEPARTMENT OF TRANSPORTATION.

GENERAL NOTES:

1. A MAXIMUM OF TWO POSTS WITHIN A 7 FOOT PATH IS PERMITTED.
2. ALL SIGN POSTS SHALL COMPLY WITH NCHRP 350.
3. ALL POSTS SHALL BE EMBEDDED A MINIMUM OF 42".
4. BRACING OF POST IS NOT PERMITTED.
5. SIGN SHALL BE LEVEL, AND UPRIGHT FOR THE DURATION OF INSTALLATION.
6. ERECT POSTS SO THE SIGN FACE AND SUPPORTS DO NOT VARY FROM PLUMB BY MORE THAN 3/16" IN 3'. PROVIDE A CENTER-TO-CENTER DISTANCE BETWEEN POSTS WITHIN 2 PERCENT OF PLAN DISTANCE.
7. NO MORE THAN ONE SPLICE PER POST, AS SHOWN, WILL BE PERMITTED.
8. POST TYPES SHALL NOT BE MIXED WITHIN A SIGN SUPPORT INSTALLATION.
9. NO VERTICAL JOINTS ARE PERMITTED IN SIGN. NO HORIZONTAL JOINTS THROUGH SIGN LEGEND OR SYMBOLS ARE PERMITTED IN SIGN
10. REMOVE SIGN POSTS AND/OR POST STUBS IN THEIR ENTIRETY WHEN NO LONGER REQUIRED.
11. ALL LABOR, MATERIALS, AND EQUIPMENT, INCLUDING TEMPORARY SUPPORTS REQUIRED TO INSTALL, MAINTAIN, RELOCATE, AND/OR REMOVE THE TEMPORARY SIGN, INCLUDING SUPPORTS, ARE CONSIDERED TO BE INCLUDED IN THE COST OF THE TEMPORARY SIGN.
12. SAW CUTS IN WOOD POSTS ARE TO BE PARALLEL TO THE BOTTOM OF THE SIGN.
13. POSTS SHALL NOT EXTEND MORE THAN 4" ABOVE TOP OF SIGN.
14. TEMPORARY WOOD SUPPORTS DO NOT REQUIRE PRESERVATIVE TREATMENT.

NOT TO SCALE

MICHIGAN DEPARTMENT OF TRANSPORTATION BUREAU OF DEVELOPMENT STANDARD PLAN	F.H.W.A. APPROVAL	11/2/2017 PLAN DATE	WZD-100-A	SHEET 11 OF 11
--	-------------------	------------------------	-----------	-------------------

NOTE: THE ORIGINAL SIGNED COPY IS KEPT ON FILE AT THE MICHIGAN DEPARTMENT OF TRANSPORTATION.

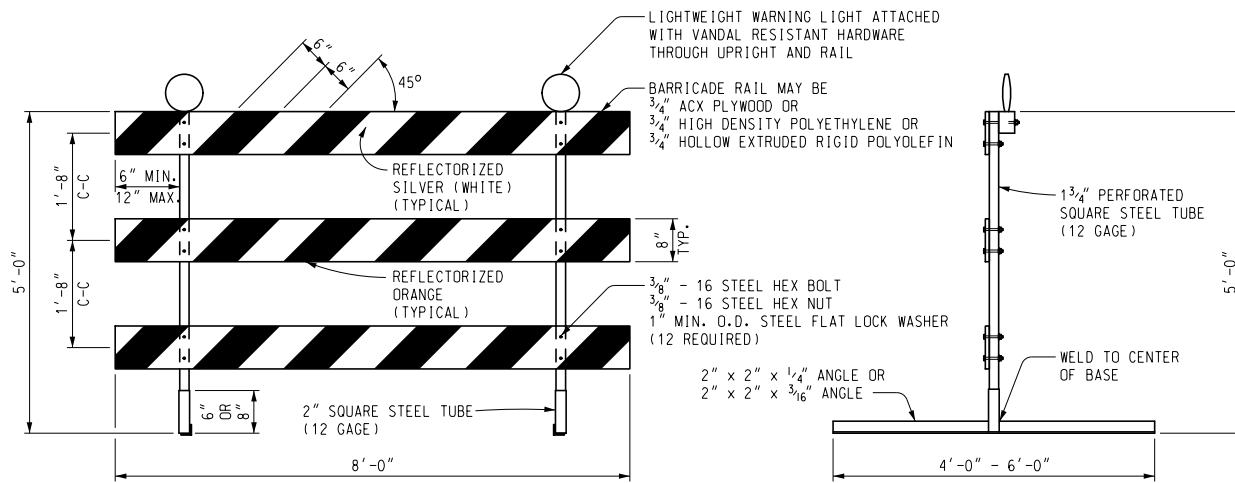

FRONT ELEVATION

SIDE VIEW

PERFORATED SQUARE STEEL TUBE OPTION

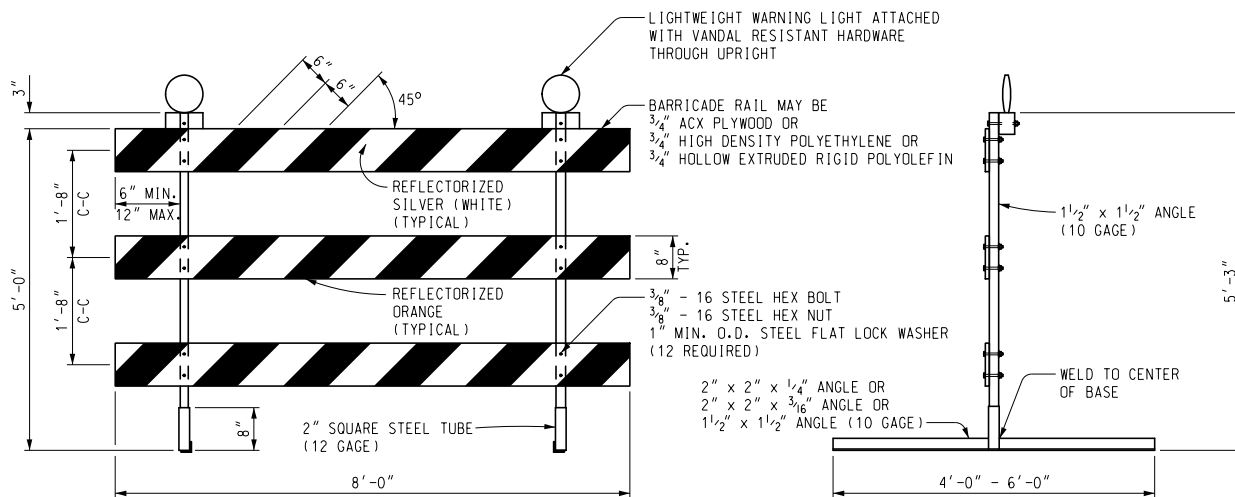

FRONT ELEVATION

SIDE VIEW

ANGLE IRON OPTION

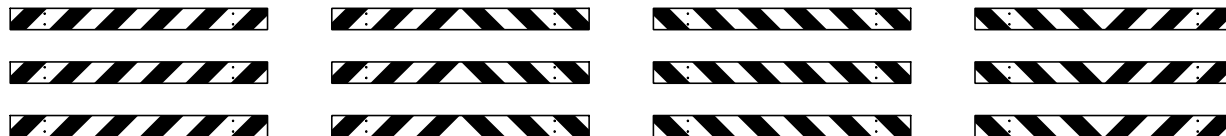

LEFT DIRECTIONAL

BI-DIRECTIONAL

RIGHT DIRECTIONAL

CLOSURES

**BARRICADE RAIL SHEETING OPTIONS
TYPE III BARRICADES**

Other Type III Barricades meeting current NCHRP crash worthy criteria can be found on the FHWA Safety website at http://safety.fhwa.dot.gov/roadway_dept/road_hardware/wzd.htm



PREPARED BY
DESIGN DIVISION

DRAWN BY: ECH

CHECKED BY: MWB

DEPARTMENT DIRECTOR
Kirk T. Steudle

APPROVED BY: _____
DIRECTOR, BUREAU OF FIELD SERVICES
ENGINEER OF DEVELOPMENT

APPROVED BY: (SPECIAL DETAIL) DS-51
DIRECTOR, BUREAU OF DEVELOPMENT

MICHIGAN DEPARTMENT OF TRANSPORTATION
BUREAU OF DEVELOPMENT STANDARD PLAN FOR

**Temporary
Traffic Control Devices**

F.H.W.A. APPROVAL

1/18/11
PLAN DATE

WZD-125-E

SHEET
1 OF 3

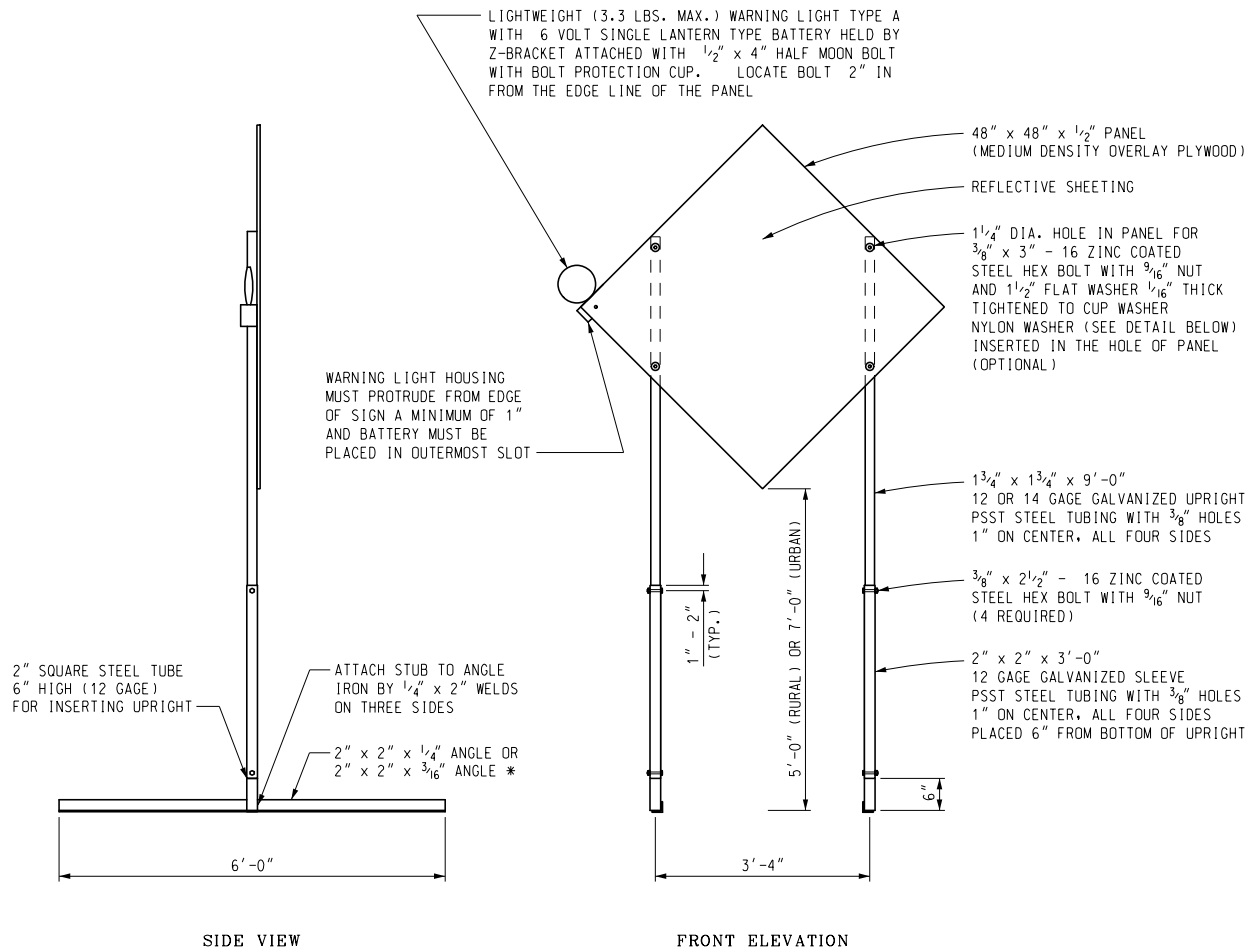

TEMPORARY SIGN SUPPORT

(WARNING LIGHT PLACED ON SIDE CLOSEST TO TRAFFIC)
 * SIGN STAND IS BALLASTED WITH FOUR OR MORE 35 LB SANDBAGS. A MINIMUM OF ONE ON EACH END.
 UPRIGHTS SHALL NOT EXTEND ABOVE THE SIGN PANEL.

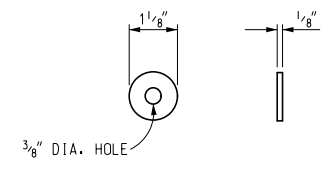
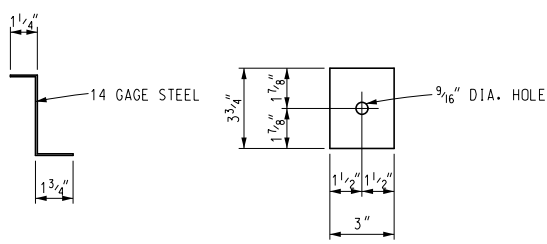

Other temporary sign supports meeting current NCHRP crash worthy criteria can be found on the FHWA Safety website at http://safety.fhwa.dot.gov/roadway_dept/road_hardware/wzd.htm

NOT TO SCALE

NOTE: THE ORIGINAL SIGNED COPY IS KEPT ON FILE AT THE MICHIGAN DEPARTMENT OF TRANSPORTATION.

- PLASTIC DRUM
- ▲▲▲ PROPOSED TYPE III BARRICADE
- △△△ EXISTING TYPE III BARRICADE

SYMBOLS TO BE USED ON PLANS

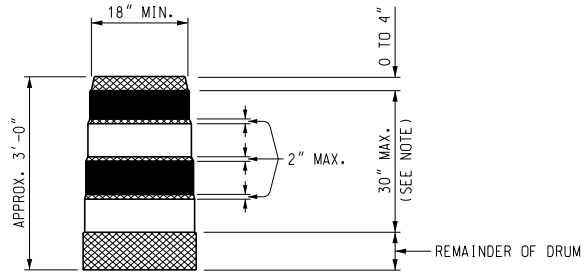

- REFLECTORIZED ORANGE
- REFLECTORIZED WHITE
- NON REFLECTORIZED ORANGE

NOTE:
 DRUMS SHALL HAVE AT LEAST 4 HORIZONTAL REFLECTORIZED STRIPES (2 ORANGE AND 2 WHITE) OF 6" UNIFORM WIDTH, ALTERNATING IN COLOR WITH THE TOPMOST REFLECTORIZED STRIPE BEING ORANGE. NON REFLECTORIZED SPACES BETWEEN THE HORIZONTAL REFLECTORIZED ORANGE AND WHITE STRIPES SHALL BE ORANGE IN COLOR AND EQUAL IN WIDTH.

PLASTIC DRUM

NOTES:

2" PERFORATED SQUARE STEEL TUBES MAY BE USED TO FABRICATE THE HORIZONTAL BASE OF THE TYPE III BARRICADE.

WARNING LIGHTS SHALL BE PLACED ACCORDING TO THE CURRENT STANDARD SPECIFICATIONS FOR CONSTRUCTION AND ALL OTHER PROVISIONS IN THE CONTRACT ON TYPE III BARRICADES.

SEE ROAD STANDARD PLANS R-113-SERIES FOR TEMPORARY CROSSOVERS FOR DIVIDED ROADWAY, AND R-126-SERIES FOR TYPICAL LOCATION AND SPACING OF PLASTIC DRUMS FOR PLACEMENT OF TEMPORARY CONCRETE BARRIER.

SIGNS, BARRICADES, AND PLASTIC DRUMS SHALL BE FACED WITH PRESSURE-SENSITIVE REFLECTIVE SHEETING ACCORDING TO THE CURRENT STANDARD SPECIFICATIONS FOR CONSTRUCTION.

SANDBAGS SHALL BE USED WHEN SUPPLEMENTAL WEIGHTS ARE REQUIRED TO ACHIEVE STABILITY OF THE BARRICADE. THE SANDBAGS SHALL BE PLACED SO THEY WILL NOT COVER OR OBSTRUCT ANY REFLECTIVE PORTION OF THE TRAFFIC CONTROL DEVICE.

NOT TO SCALE

CITY OF ANN ARBOR
DETAILED SPECIFICATION
FOR
TEMPORARY PEDESTRIAN BARRIER WITH FENCE

WT:VCM

1 of 2

01/28/19

a. Description. This work consists of furnishing, installing, maintaining, relocating, and removing a temporary pedestrian barrier with fence as identified in the proposal or on the plans. Temporary pedestrian barrier with fence is used to positively protect and separate non-motorized traffic from motorized traffic in locations where the posted speed limit is 30 miles per hour (mph) or less. In addition, temporary pedestrian barrier with fence can be used to provide separation from the work area outside the roadway, and can also be used to delineate a non-motorized facility in accordance with the *MMUTCD* in an ADA compliant manner. Temporary pedestrian barrier with fence will be replaced as directed by the Engineer.

b. Materials. Provide materials to construct a temporary pedestrian barrier with fence in accordance with the contract, the *MMUTCD*, and the following requirements:

1. Provide a base section of sufficient weight that when ballast is installed (if applicable), the section cannot be moved without mechanical means. The base section must provide a continuous detectable edge, beginning no more than 2 inches above the surface of the non-motorized facility, and extending to a minimum of 8 inches above the surface. The base section must also include design features that allows a 6-foot tall chain link fence to be securely attached to the top of the section. The face of the barrier section in contact with pedestrians and non-motorized traffic must have a smooth continuous top edge to allow hand-trailing. The base may be constructed from the following materials:

A. Temporary concrete barrier and connection hardware in accordance with subsection 812.03 of the Standard Specifications for Construction.

B. A lightweight, recyclable, linear low density, polyethylene plastic shell, with ultra violet (UV) stabilizers and anti-oxidants, designed to accept water ballast. Ensure sections are either white or safety orange and alternate in color.

2. Provide 11 gauge zinc-coated steel or aluminum-coated steel in accordance with subsection 907.04.A of the Standard Specifications for Construction. This chain-link fence should be 6 feet tall and include appropriate posts and hardware to connect to the barrier sections, and connect to form a continuous fence with no breaks along the installation.

3. If installed in the presence of motor vehicle traffic, the normal posted speed limit (prior to construction) must be 30 mph or less, the barrier installation must meet *National Cooperative Highway Research Program Report 350 (NCHRP 350) Test Level 1 (TL-1)* or *Manual for Assessing Safety Hardware (MASH) Test Level 1 (TL-1)* requirements. If required, provide a temporary barrier ending in accordance with

subsection 812.03.D.10 of the Standard Specifications for Construction (paid for separately).

c. Construction. Install the temporary pedestrian barrier with fence in accordance with the manufacturer’s requirements, the plans, as per the direction of the Engineer, and the following:

1. Place sections at the locations shown on the plans. Securely connect all barrier sections in accordance with the manufacturer’s specifications. If water filled barrier sections are used, alternate colors along the installation to increase conspicuity. Install fence sections such that no gaps are present that may allow pedestrians into closed areas or into an active traffic lane.

2. If required, install water ballast to the manufacturer recommended level. If water filled barrier sections are used during freezing temperatures, install an environmentally safe anti-freezing agent to ensure liquid does not freeze per the manufacturer’s recommendations. Ensure frozen water-filled barrier sections are replaced immediately at no cost to the Department. When the barrier sections are removed, ensure any anti-freezing agents are securely collected and properly disposed of.

3. Install the temporary barrier ending if required.

4. Ensure that the barrier installation meets *MMUTCD*, and *NCHRP 350, TL-1 or MASH, TL-1* requirements at all times when in use. Routinely inspect ballast levels (if applicable) and refill or replace barrier sections if needed.

d. Measurement and Payment. The completed work, as described, will be measured and paid for at the contract unit price using the following pay item:

Pay Item	Pay Unit
Item 216: Pedestrian Barrier With Fence, Temp.....	Foot

Pedestrian Barrier With Fence, Temp includes all labor, equipment, and materials to furnish, install, maintain, relocate, and remove a temporary pedestrian barrier with fence, at the locations shown on the plans.

CITY OF ANN ARBOR
DETAILED SPECIFICATION
FOR
TEMPORARY PEDESTRIAN TYPE II BARRICADE

WT:VCM

1 of 2

01/28/19

a. Description. This work consists of furnishing, installing, maintaining, relocating, and removing a temporary pedestrian Type II barricade section as identified in the proposal or on the plans. Use temporary pedestrian Type II barricades to close non-motorized facilities including sidewalks, bicycle paths, pedestrian paths, and shared use paths that are not part of the roadway. One pedestrian Type II barricade is defined as a barricade section at least 43 inches wide, including all supports, ballast, and hardware.

b. Materials. Provide a temporary pedestrian Type II barricade that meets the requirements of *National Cooperative Highway Research Program Report 350 (NCHRP 350)* or *Manual for Assessing Safety Hardware (MASH)*, in addition to meeting the following requirements:

1. Provide barricade sections at least 43 inches wide, designed to interconnect to ensure a continuous *Americans with Disabilities Act (ADA)* compliant tactile barrier. Ensure the connection includes provisions to accommodate non-linear alignment as well as variations in elevation at the installation area.

2. Ensure the top surface of the barricade is designed to function as a hand-trailing edge, and has a height between 32 and 38 inches. Ensure the lower edge of the barricade is no more than 2 inches above the surface of the non-motorized facility. Ensure the top edge of the bottom rail of the barricade is a minimum of 8 inches above the surface of the non-motorized facility. The barricade may have a solid continuous face. Finally, all features on the front face of the barricade (the face in contact with pedestrians) must share a common vertical plane.

3. Equip both sides of the barricade with bands of alternating 6-inch wide orange and white vertical stripes of reflective sheeting. Two bands of sheeting 6 inches tall and a minimum of 36 inches long containing at least two orange and two white stripes each are required. One band placed near the top and one near the bottom if the barricade section has a solid face. If the barricade consists of two rails, affix one band of sheeting to each rail. Ensure the stripes of reflective sheeting are aligned vertically. Ensure this sheeting meets or exceeds the requirements of *ASTM D 4956* Type IV sheeting.

c. Construction. Construct the temporary pedestrian Type II barricade in accordance with the manufacturer's recommendations, Michigan Manual on Uniform Traffic Control Devices (MMUTCD), the plans, and the following requirements:

1. Install the barricade as shown on the plans and as directed by the Engineer. Interconnect all barricade sections using hinge components if necessary to ensure a continuous detectable edge for the entire installation. Ensure the barricade is

ballasted according to the manufacturer’s recommendations to ensure stability during wind events and contact with pedestrians.

2. When the barricade is installed near motor vehicle traffic, ensure reflective sheeting is visible to motorists.

3. When pedestrian Type II barricades are used to close a non-motorized facility, ensure a sufficient number of barricade sections are used to block the entire width of the facility. The barricade may extend outside the edge of the non-motorized facility but must not be less than the full width of the facility.

4. If sections of multiple colored barriers are used (i.e. safety orange and white) install the sections such that the colors alternate to increase conspicuity.

5. Ensure pedestrian Type II barricades are not used to close a motor vehicle facility. Ensure these barricades are not used to guide pedestrian traffic on a motor vehicle facility in the presence of active traffic. This prohibition includes bicycle/shared use lanes or shoulders in the presence of active traffic.

d. Measurement and Payment. The completed work, as described, will be measured and paid for at the contract unit price using the following pay item:

Pay Item	Pay Unit
Item 217: Pedestrian Type II Barricade, Temp	Each

Pedestrian Type II Barricade, Temp, includes all labor, equipment, and materials to furnish, install, maintain, relocate, and remove one barricade section that is at least 43 inches wide. Additional payment will not be made if wider sections are provided. This includes all rails, supports, ballast, hinge points, reflective sheeting, and miscellaneous hardware needed to install and maintain a barricade section.

CITY OF ANN ARBOR
DETAILED SPECIFICATION
FOR
TEMPORARY PEDESTRIAN TYPE II CHANNELIZER

WT:VCM

1 of 2

01/28/19

a. Description. This work consists of furnishing, installing, maintaining, relocating, and removing temporary pedestrian channelizers as identified in the proposal or on the plans. Use temporary pedestrian channelizers to guide pedestrians along a temporary non-motorized facility, and to create separation of pedestrians from construction areas near existing facilities. Replace damaged temporary pedestrian Type II channelizers as directed by the Engineer.

b. Materials. Provide a temporary pedestrian channelizer that is crashworthy according to the *National Cooperative Highway Research Program Report 350* (NCHRP 350) or *Manual for Assessing Safety Hardware* (MASH), in addition to meeting the following requirements:

1. Ensure the channelizer is designed to interconnect to maintain continuous delineation along the entire installation. This includes provisions to accommodate non-linear alignment as well as variations in elevation.

2. Ensure the top surface of the channelizer is designed to function as a hand-trailing edge, and have a height between 32 and 38 inches. Ensure this top surface is designed to have a 2 inch horizontal gap between the top edge and the support (if so equipped), to allow for continuous hand-trailing without obstructions. Ensure the lower edge of the channelizer is no more than 2 inches above the surface of the non-motorized facility. Ensure the top edge of the bottom rail of the channelizer is a minimum of 8 inches above the surface of the non-motorized facility or the channelizer may have a solid continuous face. Finally, all features on the front face of the channelizers (the face in contact with pedestrians) must share a common vertical plane.

3. Equip both sides of the channelizer with bands of alternating 6-inch wide orange and white vertical stripes of reflective sheeting. Two bands of sheeting 6 inches tall and a minimum of 36 inches long containing at least two orange and two white stripes each are required. One band placed near the top and one near the bottom if the channelizer section has a solid face. If the channelizer consists of two rails, affix one band of sheeting to each rail. Ensure the stripes of reflective sheeting are aligned vertically. Ensure this sheeting meets or exceeds the requirements of *ASTM D 4956* Type IV sheeting.

c. Construction. Deploy the temporary pedestrian Type II channelizer in accordance with the manufacturer's recommendations, the Michigan Manual on Uniform Traffic Control Devices (MMUTCD), the plans, and the following requirements:

1. Install the channelizer as shown on the plans and as directed by the Engineer. Interconnect all channelizers using hinge components if necessary to ensure a

continuous detectable edge for the entire installation. Ensure the channelizers are ballasted according to the manufacturer’s recommendations to ensure stability during wind events and contact with pedestrians.

2. When the channelizers are installed near motor vehicle traffic, ensure reflective sheeting is visible to motorists providing appropriate delineation for the pedestrian path.

3. If sections of multiple colored barriers are used (i.e safety orange and white), install the sections such that the colors alternate to increase conspicuity.

4. Ensure temporary pedestrian Type II channelizers are not used to guide pedestrian traffic on a motor vehicle facility in the presence of active traffic. This prohibition includes bicycle/shared use lanes or shoulders in the presence of active traffic. Ensure temporary pedestrian channelizers are not used to channelize motor vehicle traffic, or separate motor vehicle and pedestrian traffic.

d. Measurement and Payment. The completed work, as described, will be measured and paid for at the contract unit price using the following pay item:

Pay Item	Pay Unit
-----------------	-----------------

Item 218: Pedestrian Type II Channelizer, Temp	Foot
--	------

Pedestrian Type II Channelizer, Temp includes all labor, equipment, and materials to furnish, install, maintain, relocate and remove rails or wall sections, supports, ballast, and hinge points at the locations shown on the plans. This includes all rails or wall sections, supports, ballast, hinge points, and miscellaneous hardware needed to construct the channelizer or system of channelizers.

CITY OF ANN ARBOR
DETAILED SPECIFICATION
FOR
TEMPORARY PEDESTRIAN PATH

WT:VCM/CEW

1 of 2

01/28/19

a. Description. This work consists of furnishing, installing, maintaining, and removing a temporary pedestrian path as identified in the proposal or on the plans. Temporary pedestrian paths, or segments thereof, will be repaired or replaced as directed by the Engineer.

b. Materials. Provide materials to construct a temporary pedestrian path in accordance with the contract, the *Public Right of Way Accessibility Guidelines (PROWAG)*, the *MMUTCD*, as directed by the Engineer, and the following requirements:

1. Ensure the materials used to construct the temporary pedestrian path yields a continuous hard surface that is firm, stable and skid resistant. Ensure the path does not warp, buckle or otherwise become uneven, and materials support the weight of pedestrians as well as motorized scooters and wheelchairs. Suitable materials to construct the path include asphalt materials, Oriented Strand Board (OSB), plywood, dimensional lumber, reclaimed, or other as approved by the Engineer. Compacted soils, aggregate and sand are prohibited.

2. If asphalt materials are not used to construct the path, provide an antiskid coating, or surface treatment as directed by the Engineer.

c. Construction. Construct the temporary pedestrian path in accordance with *PROWAG*, the *MMUTCD*, the contract, the direction of the Engineer, and the following:

1. The useable surface of the path must be a minimum of 48 inches wide, additional width may be provided to preclude the use of Temporary Pedestrian Passing Spaces (paid for separately). A minimum width of 60 inches is required if Temporary Pedestrian Passing Spaces are not provided as part of the temporary facility. The maximum cross slope for the path is 2 percent. The path, including transitions to the adjacent surface at both ends, must be free of vertical discontinuities greater than 1/4 inch. Eliminate any vertical discontinuities greater than 1/4 inch up to 1/2 inch or bevel with a slope not steeper than 1:2. If a vertical discontinuity greater than 1/2 inch or a running slope greater than 1:20 occurs on the project, a Temporary Pedestrian Ramp (paid for separately) is required.

A. Ensure an anti-skid surface treatment is applied to the surface of the path, if not constructed with asphalt materials, as directed by the Engineer.

B. If the surface of the path is constructed from OSB, plywood, or dimensional lumber securely connect all sections with appropriate fasteners to ensure a continuous, uniform and flat surface.

2. Ensure all debris and construction materials is cleared from the path throughout its use. Ensure snow and ice is removed; the use of an approved de-icing agent may be required.

3. Repair or replace the path, or segments thereof, if it becomes uneven, unstable, or displaces due to weather events, construction activities, or other causes as directed by the Engineer.

4. Following the use of the temporary path, the Contractor must remove and dispose all materials used to construct the path, and restore the area as directed by the Engineer.

d. Measurement and Payment. The completed work, as described, will be measured and paid for at the contract unit price using the following pay item:

Pay Item	Pay Unit
Item 219: Pedestrian Path, Temp.....	Foot

Pedestrian Path, Temp will be measured along the centerline of the path. **Pedestrian Path, Temp** includes all costs related to installation, maintenance, restoration, and removal of the path and disposal of all associated materials throughout the life of the contract.

CITY OF ANN ARBOR
DETAILED SPECIFICATION
FOR
TEMPORARY PEDESTRIAN RAMP

WT:VCM

1 of 3

01/28/19

a. Description. This work consists of furnishing, installing, maintaining, relocating, and removing a temporary pedestrian ramp as identified in the proposal or on the plans. Use temporary pedestrian ramps to facilitate pedestrian travel on accessible facilities over curbs or other uneven terrain features with a vertical difference of 1/2 inch or greater. Damaged pedestrian ramps will be replaced as directed by the Engineer.

b. Materials. Provide materials to construct a temporary pedestrian ramp in accordance with the *Americans with Disabilities Act (ADA)*, the standard specifications, and the following:

1. Ensure the material used to construct the temporary pedestrian ramp is firm, stable, skid resistant, and forms a continuous hard surface. Ensure the surface does not warp, buckle or otherwise become uneven, and materials support the weight of pedestrians as well as motorized scooters and wheelchairs. Suitable materials to construct the surface of the ramp include asphalt materials, Oriented Strand Board (OSB) or plywood, dimensional lumber, certain reclaimed or other materials as approved by the Engineer. Compacted soils, aggregate and sand are prohibited.

2. Provide a handrail on both sides of the ramp if the ramp is not exposed to vehicle traffic and has a total rise greater than 6 inches, and a length greater than 72 inches. Ensure the handrail is between 1.25 and 1.5 inches wide and configured to be a “graspable” cross-section. See construction subsection 2.A for additional details. When the ramp is exposed to traffic, in lieu of handrails, use a protective edge 2.5 inches minimum height above the ramp surface or 1:10 flare on both sides of the ramp.

3. Ensure the surface of the ramp is free draining; in addition, provide features that allow drainage to move past the ramp installation (i.e. along the gutter pan underneath the ramp if the ramp is installed on a curb).

4. Provide materials to construct detectable edging along open sides of the ramp if required.

5. If asphalt materials are not used to construct the surface of the ramp, provide an antiskid coating or surface treatment approved by the Engineer.

c. Construction. Construct the temporary pedestrian ramp in accordance with the manufacturer’s recommendations (if applicable), *ADA*, the plans, and the following:

1. Ensure the useable surface of the ramp is 48 inches wide and does not deflect due to pedestrian traffic. Ensure an anti-skid surface treatment is applied to the useable area of the ramp if it is not made from asphalt materials. The maximum cross

slope of the ramp is 2 percent. Ensure both ends of the ramp smoothly transitions to the adjacent surface, with 1/4 inch or less vertical difference.

Construct the ramp to maintain a longitudinal slope from 1:10 to 1:12 where possible. Otherwise, a longitudinal slope from 1:8 to 1:10 may be used for a maximum rise of 3 inches. Temporary pedestrian ramps with longitudinal slopes greater than 1:8 are prohibited.

A. Provide a handrail on both sides of the ramp if required as stated herein. Ensure the top of the handrail is between 34 and 38 inches above the surface of the ramp. Ensure a minimum width of 36 inches is maintained between the handrails, with a minimum clearance of 1.5 inches behind and 18 inches above.

Construct the handrail such that the bending stress applied by a bending moment created by a 250 pound force is less than the allowable stress for the materials and the construction of the handrail. Construct the handrail to withstand the shear stress induced by a 250 pound force. Ensure all fasteners, mounting devices and support structures are also able to withstand shear stress induced by a 250 pound force.

2. Construct a detectable edging anytime a handrail is required, and anytime the path changes direction. This includes a turn onto the ramp from the path. Detectable edging must begin a maximum of 2.5 inches above the ramp surface, and extend at least 6 inches above the ramp surface.

3. Ensure a clear space (minimum 48 inches by 48 inches) is provided above and below the ramp.

4. Avoid locating ramps in areas of drainage collection, ponding or running water, which can produce slippery or unsafe conditions. If the ramp is located over a gutter pan or other drainage structure, provide features to facilitate water movement around or under the ramp as approved by the Engineer.

5. Ensure all debris and construction material is cleared from the surface of the ramp throughout its use. Ensure snow and ice is removed; the use of an approved de-icing agent may be required. Repair or replace the ramp if it becomes uneven, unstable, or displaces due to weather events, construction activities, or other causes as directed by the Engineer.

d. Measurement and Payment. The completed work, as described, will be measured and paid for at the contract unit price using the following pay item:

Pay Item	Pay Unit
Item 220: Pedestrian Ramp, Temp.....	Each

Pedestrian Ramp, Temp includes all labor, equipment, and materials to furnish, install and remove a temporary pedestrian ramp at the locations shown on the plans, as well as all costs for maintaining, clearing debris, deicing, reconfiguring, and relocating the temporary pedestrian ramp throughout the life of the contract.

CITY OF ANN ARBOR
DETAILED SPECIFICATION
FOR
PERMANENT PAVEMENT MARKINGS

WT:VCM/CEW

1 of 2

01/28/19

DESCRIPTION

This work consists of providing and placing permanent pavement markings in accordance with the Michigan Manual of Uniform Traffic Control Devices (MMTUTCD), latest version published at time of advertisement. Provide pavement markings that conform to the Plans, the Michigan Department of Transportation (MDOT) 2012 Standard Specifications for Construction, MDOT Pavement Marking Standard Plans, City of Ann Arbor Special Details, and as specified herein.

MATERIALS

Provide materials in accordance with section 811 and 920 of the MDOT 2012 Standard Specifications for Construction. Provide the Material Safety Data Sheets to the Engineer for required materials and supplies. Dispose of unused material and containers in accordance with the Federal Resource Conservation Recovery Act (RCRA) of 1976 as amended, and 1994 PA 451, Part 111 Hazardous Waste Management. Provide samples of permanent marking materials upon request.

Preformed Thermoplastic - Ensure the pavement is free of excess surface and subsurface moisture that may affect bonding. The Engineer will not decide the suitability of specific days for the application of preformed thermoplastic. Heat and apply the Preformed thermoplastic material as recommended by the manufacturer. Feather all edges of the material with a putty knife while the preformed thermoplastic is still soft.

CONSTRUCTION METHODS

The preparation and placement of permanent markings shall conform to section 811 of the MDOT 2012 Standard Specifications, the Plans, and as specified herein.

MEASUREMENT AND PAYMENT

Completed work, as described, will be measured and paid for at Contract Unit Prices for the following Contract (Pay) Items:

Contract Pay Item

Pay Unit

Item 221: Pavt Mrkg, Sprayable Thermopl, __ inch, (Color).....	Foot
Item 222: Pavt Mrkg, Thermoplastic, __ inch Stop Bar.....	Foot
Item 223: Pavt Mrkg, Thermopl, __ inch Crosswalk	Foot
Item 224: Pavt Mrkg, Ovly Cold Plastic, _____ Sym	Each

The unit prices for these items of work shall include all labor, material, and equipment costs to perform all the work specified in the MDOT 2012 Standard Specifications for Construction and as modified by this Detailed Specification.

CITY OF ANN ARBOR
DETAILED SPECIFICATION
FOR
MINOR TRAFFIC DEVICES, MAX. \$_____

WT:VCM

1 of 2

01/17/19

a. Description.- This work shall consist of protecting and maintaining vehicular and pedestrian traffic in accordance with the City of Ann Arbor Standard Specifications for Construction; Section 812 of the 2012 MDOT Standard Specifications for Construction; Part 6 of the Michigan Manual of Uniform Traffic Control Devices, Latest Revised Edition (MMUTCD); this Detailed Specification; and, as shown on the plans and as directed by the Engineer.

This item of work shall include, but not be limited to:

- The furnishing and operating of miscellaneous signs, warning devices, flag-persons, temporary concrete barriers, and drums, channelizing devices, cones as required for the entire duration of the project;
- The operation of additional signs furnished by the City;
- Furnishing and installing meter bags (where required);
- Coordinating with the City to have meter heads removed and reinstalled (where required);
- Coordinating with the City on signal timing and phasing changes;
- Maintaining pedestrian traffic;
- Temporarily covering conflicting traffic controls with Engineer-approved covers;
- Temporarily covering conflicting existing signs as directed by the Engineer with approved sign covers; and,
- Any and all other miscellaneous and/or incidental items that are necessary to properly and safely perform the work.

The Contractor shall maintain vehicular and pedestrian traffic during the work by the use of flag-persons, channelizing devices, and signs as necessary, as directed by the Engineer, and in accordance with MMUTCD.

Typical applications for maintaining pedestrian traffic in accordance with the MMUTCD are included in plan set for this project.

b. Materials.- Traffic maintenance material and equipment shall meet the requirements as specified in Section 812.02 of the 2012 MDOT Standard Specifications for Construction.

c. Construction Methods.- All temporary traffic/pedestrian control devices furnished by the Contractor shall remain the property of the Contractor. The City shall not be responsible for stolen or damaged signs, barricades, barricade lights or other traffic maintenance items. The Contractor shall replace missing traffic control devices immediately and at no additional cost to the City.

All existing signs, and signs erected by the City of Ann Arbor, on this project shall be preserved, protected, and maintained by the Contractor. Existing City-owned signs that are damaged by the Contractor during the work will be repaired by the City at the Contractor's expense.

The Contractor shall temporarily cover conflicting traffic and/or parking signs when directed by the Engineer.

When traffic control devices have been damaged by, or due to, the negligence of the Contractor, his subcontractors or material suppliers, the traffic control devices shall be replaced at the Contractor's sole expense.

The Contractor shall furnish and install the traffic control items as shown on the contract plan sheets and details included therein.

"Road Work Ahead" warning signs shall be placed, as indicated on the Plans, or as directed by the Engineer, prior to the start of work, regardless of the nature, magnitude or duration of the work.

Removable black pavement marking cover tape shall be used to cover conflicting pavement markings as directed by the Engineer.

Temporary pavement markings may be used within transition areas, if requested by the Contractor, and approved by the Engineer. All temporary pavement markings shall be removable.

d. Measurement and Payment.- This item of work will be paid for on a pro-rata basis at the time of each progress payment. Measurement will be based on the ratio between work completed during the payment period and the total contract amount. When all of the work of this Contract has been completed, the measurement of this item shall be 1.0 Lump Sum.

The completed work as measured for this item of work shall be paid for at the contract unit price for the following contract item (Pay Item):

<u>Pay Item</u>	<u>Pay Unit</u>
Item 226: Minor Traffic Devices, Max. _____	Lump Sum

The unit price for this item of work shall include all labor, material, and equipment costs required to perform the work specified herein.

CITY OF ANN ARBOR
DETAILED SPECIFICATION
FOR
PARKING METERS

WT:VCM

1 of 2

01/17/19

a. Description. This work shall consist of removing parking meter standards and installing new meter standards where directed.

b. Materials. Republic Parking System will supply all standards. Standards are steel tubes 60 to 63 inches in length and 2 inches square.

All sand shall meet the gradation of MDOT Class II granular material in accordance with Section 902 of the 2012 MDOT Standard Specifications for Construction.

Concrete shall be Grade P2 in accordance with Section 601 of the MDOT 2012 Standard Specifications for Construction.

c. Construction.

1. Removal. The City will locate and mark meter standards requiring removal. Prior to removal, contact Republic Parking System at (734) 761-7235 for the removal of the parking meter heads. The Contractor will not remove the meter heads, nor remove the standard with the meter head still in place.

The Contractor shall removal the standard and concrete foundation. The void is to be backfilled with Class II Granular Material or Engineer approved backfill. Surface shall be restored in-kind to adjacent material. Concrete sidewalk shall comply with plans and specifications. Turf establishment shall comply with plans and specifications. The standards and concrete will then become of the property of the Contractor and shall be properly disposed of offsite.

2. Parking Meter Head Covers - The Contractor shall coordinate with RPS to have meter bags installed on the meter heads a minimum of 24-hours prior to the desired time of enforcement. The City will require written documentation from the Contractor that the meter bags are in place. The Parking Enforcement Office will be unable to enforce the desired "No-Parking Zone" unless the RPS installs the meter bags in a timely manner.

The Contractor has the sole responsibility for coordinating with RPS for the placement and maintenance of the meter bags, and delays due to unrestricted on-street parking shall not be cause for any claim for extra payments to the Contractor.

Further information regarding the placement of meter bags and the temporary prohibition of on-street parking is available from RPS.

Republic Parking System will waive all meter bag rental fees for this project. The Contractor will be responsible for all costs associated with the placement of meter bags required by the project. Costs associated with placement of meter bags will not be paid for separately but shall be included in the bid price of the Contract Item “**General Conditions, Max \$_____**”.

d. Measurement and Payment. Measure and pay for the completed work, as described, at the contract unit price using the following pay items:

<u>Pay Item</u>	<u>Pay Unit</u>
Item 228: Parking Meters, Remove	Each

Measure **Parking Meters, Remove** individually in place by the unit each and pay for them at their respective contract unit prices, which prices include the costs for all labor, equipment and materials necessary to complete the work.

Disposal of existing standards, concrete foundations, all excavated material, and material to backfill voids after removing the standards is included in the pay item **Parking Meters, Remove**.

CITY OF ANN ARBOR
SPECIAL PROVISION
FOR
SOIL EROSION CONTROL INLET FILTER

WT:VCM

1 of 1

01/17/19

a. Description.- This work consists of installing and maintaining inlet filters in accordance with Section 208 of the 2012 Michigan Department of Transportation Standard Specifications for Construction and as shown on the plans. Filters shall be installed in existing and proposed inlets in order to minimize the erosion of soil and the sedimentation of water courses. The related work includes the installation, maintenance and removal of the filter cloth, cleaning as required during the performance of the project work, removing and disposing of accumulated sediment, and replacement of filters if required by the Engineer so as to provide a properly working inlet filter and a well-drained site.

b. Materials.- The inlet filters shall be in accordance with the REGULAR FLOW SILTSACK® manufactured by ACF Environmental (800) 448-3636; FLEXSTORM® Style FX manufactured by Advanced Drainage Systems, Inc. (800) 821-6710; CATCH-ALL® manufactured by Price & Company (866) 960-4300, or Engineer approved equal.

The Contractor shall submit product data sheets and a sample of the filter material for inlet filters for Engineer approval prior to ordering materials.

c. Methods of Construction.- The Contractor shall install, maintain, clean, and re-install and/or replace inlet filters in accordance with the manufacturer's specifications and as directed by the Engineer. The Contractor shall dispose of debris off-site.

d. Measurement and Payment.- The completed work of Soil Erosion Control Inlet Filter will be paid for at the contract unit price for the following contract items (pay items):

<u>Contract Item (Pay Item)</u>	<u>Pay Unit</u>
Item 229: Erosion Control, Inlet Filter	Each

"Erosion Control, Inlet Filter" will be measured by the unit installed and will be paid for at the contract unit price per each, for which price shall be payment in full for all labor, equipment, and materials needed to furnish, install, maintain, clean and remove the inlet filter, and re-install and/or replace the inlet filter as needed.

CITY OF ANN ARBOR
 DETAILED SPECIFICATION
 FOR
**SEWER, ANY SIZE OR DEPTH, REM
 DR STRUCTURE, ANY SIZE OR DEPTH, REM**

WT:VCM

1 of 1

01/17/19

a. Description.- This work shall consist of furnishing all labor, tools, equipment, and material to remove, and dispose of off-site, sewers, and/or drainage structures, in accordance with Section 203 of the 2012 Michigan Department of Transportation Standard Specifications for Construction, and as specified herein.

b. Materials.-

Granular Material, Class II.....Section 902

c. Construction Methods.- Sewers, manholes, and drainage structures shall be removed, and disposed of off-site, in such a manner as not to damage any new work, or work or material which is to remain in-place. The hole or trench resulting from the removal of the manhole, sewer, or drainage structure shall be backfilled with Granular Material, Class II, in maximum lifts of 12 inches, and be compacted to 95% of its maximum unit weight, if located within the public rights-of-way, railroad rights-of-way, or within the influence paved surfaces or structures. Otherwise, backfill shall be Engineer approved native material, compacted to 90% of its maximum unit weight, in lifts of 12 inches or less, unless otherwise noted on the plans. The resulting hole left in a structure from a sewer to be removed shall be bulkheaded with bricks and mortar to provide a watertight seal and constructed such that the remaining flow in the manhole is not impeded.

As directed by the Engineer and within two days of their removal, the Contractor shall stockpile on-site, in a location that is mutually agreeable to the Engineer and Contractor, the existing structure covers. The City of Ann Arbor's forces will pick-up the structure covers at a time that is convenient to them and mutually agreeable to the Contractor. The Contractor shall provide the equipment and manpower to load the castings on the City's vehicle(s) so that they can be removed from the site by the City.

d. Measurement and Payment.- The completed work shall be paid for at the Contract Unit Price for the following Contract Items:

<u>Contract Item (Pay Item)</u>	<u>Pay Unit</u>
Item 230: Sewer, Any Size or Depth, Rem	Foot
Item 231: Dr Structure, Any Size or Depth, Rem	Each

Payment for the above items shall include all labor, material and equipment to complete the work of removing sewers and drainage structures of any size or depth as detailed herein.

CITY OF ANN ARBOR
SPECIAL PROVISION
FOR
REMOVING PAVEMENT AND CONCRETE ITEMS

WT:VCM

1 of 2

01/28/19

a. Description.- This work shall consist of furnishing all labor, tools, equipment, and material to remove, and dispose of off-site, any concrete curb, gutter, curb and gutter, integral curb, sidewalk, sidewalk ramps, pavement, drive openings, and drive approach pavements as shown on the plans, in accordance with section 204 2012 MDOT Standard Specifications for Construction, except as specified herein, and as directed by the Engineer.

b. Materials.

Granular Material, Class II.....Section 902

c. Construction.- Construction methods shall be as described in section 204 of the MDOT 2012 Standard Specifications for Construction, as described below, and as directed by the Engineer.

The pay item for **“Pavement, Remove”** will include removal of existing pavement regardless of pavement depth, type or material. Also included is bituminous overlay pavement on the concrete gutter without disturbing the curb and gutter remaining in place.

Prior to the start of work, the Engineer and Contractor together shall identify and field measure all items to be removed. The Engineer shall approve of all removal limits prior to any removals being performed by the Contractor.

The Contractor shall perform full-depth saw cutting at removal limits as necessary to construct the curb and gutter as shown on the Plans, as directed by the Engineer, and as marked for removal.

The Contractor shall cut steel reinforcement bars as directed by the Engineer at all areas of removal.

All saw cutting shall be performed under wet conditions to prevent excessive airborne dust. All resulting slurry and debris shall be cleaned up the satisfaction of the Engineer.

The Contractor shall coordinate with the City Forester prior to the removal of any tree roots.

Excavated/removal areas shall be adequately protected with barricades and/or fencing at all times.

Removed or excavated materials which are not incorporated into the work shall become the property of the Contractor and shall be immediately removed and properly disposed

of off-site. Removed or excavated materials may not be stockpiled overnight on, or adjacent to, the site.

Base, subbase, or subgrade materials removed without authorization by the Engineer shall be backfilled with MDOT Class II Granular Material compacted to 95% of its maximum dry density at no additional cost to the project.

d. Measurement and Payment. The completed work, as described, will be measured and paid for at the respective contract unit prices for the following respective pay items:

Pay Item	Pay Unit
Item 233: Curb and Gutter, Any Type or Size, Rem	Foot
Item 234: Sidewalk and Ramps, Remove.....	Square Foot
Item 235: Driveway Approach, Remove	Square Foot
Item 236: Pavement, Remove	Square Yard

All sawcutting required for removals shall be included in the appropriate item of work and will not be paid for separately.

Payment will be based on the area of pavement removed, regardless of thickness, or if it is composite.

CITY OF ANN ARBOR
SPECIAL PROVISION
FOR
MACHINE GRADING, MODIFIED

WT:VCM

1 of 7

01/17/19

a. Description.- The pay item “Machine Grading, Modified, ___” shall be completed in accordance with Section 205 of the Michigan Department of Transportation 2012 Standard Specifications for Construction (MDOT 2012 SSC) and shall include all work indicated in the MDOT 2012 SSC, shown on the plans, and as specified herein, with the exception that “Subgrade Undercutting, Type __,” and “Subgrade Manipulation,” shall be paid for separately when separate pay items for the respective items are included in the proposal. “Machine Grading, Modified, ___” shall include all the work specified herein for which there is no separate pay item.

The following abbreviated table of contents for Section 205 (Roadway Earthwork) of the MDOT 2012 SSC is provided for reference. It is not a complete table of contents for all Section 205 work required to complete the project.

<u>Section / Title</u>	<u>Page</u>
205.01 Description	127
205.02 Materials	127
205.03 Construction.....	128
A. Preparing Roadway Foundation	128
1. Removing and Salvaging Topsoil	128
B. Rock Excavation	129
E. Subgrade Undercutting	130
F. Subgrade Manipulation.....	131
G. Earth Excavation.....	131
H. Roadway Embankment.....	132
1. Placing and Compacting Embankment.....	134
205.04 Measurement and Payment	140

b. Soils Information.- Soil information provided as part of the contract documents is for informational purposes only and shall not relieve the Contractor of the responsibility of investigating all local conditions before bidding.

c. Materials.- All materials and mixtures shall meet the requirements as specified in Section 205 of the MDOT 2012 Standard Specifications for Construction, except as specified herein.

d. General Provisions.- The Contractor shall:

1. Maintain access to all drive entrances at all times.
2. Maintain pick-up access for garbage and recycle vehicles at all times.
3. Maintain access to all mail boxes for users and the U.S. Postal Service at all times. The Engineer may direct the temporary relocation of mail boxes. The Contractor may propose the temporary relocation of mail boxes, subject to the approval of the Engineer. In either case, the temporary relocation of mail boxes will not be paid for separately.
4. Grade around mailboxes, trees, light poles, power poles, and the like, which are to remain in place. The Contractor shall be responsible for any damage caused to such structures.
5. Coordinate all work with utility companies and others that need to complete work within the project limits.
6. Maintain the work in a finished condition until it is accepted by the Engineer.

e. Pavement Sawcutting.- The work shall include the full-depth saw-cutting of pavement at the construction limits, and elsewhere as required, if not paid for as part of another item of work. Pavement sawcutting will not be paid for separately.

f. Removal of Trees and Vegetation.- The Contractor shall remove and properly dispose of off-site all vegetation; brush; roots; and trees and stumps less than 6 inch in diameter, as shown on the plans, and as directed by the Engineer as required to complete the project.

g. Removal and Salvaging of Topsoil.- The removal, salvaging and stockpiling of topsoil, and all related work, shall be performed in accordance with Section 205.03.A.1 (Removing and Salvaging Topsoil) of the MDOT 2012 SSC.

h. Miscellaneous Removals.- The removal of bituminous, aggregate, and/or concrete materials from around manholes, structures, and utility covers, and the removal of bituminous curbing, bituminous driveway wedges, and bituminous surfaces around other miscellaneous unremoved areas shall be paid for as "Machine Grading, Modified, ____" and will not be paid for separately.

"Machine Grading, Modified, ____" includes the removal of any surface feature located within the grading limits which must be removed and for which there is no specific pay item established in the proposal for its removal.

i. Protection of the Grade.- The work shall be kept well drained at all times. Foundation, roadway or sidewalk embankment or subgrade that becomes damaged by rain shall be undercut and backfilled, or otherwise remedied, by the Contractor, at his/her sole expense, as directed by the Engineer.

The Contractor shall be responsible for the maintenance of the foundation, roadway embankment, and subgrade. Any damage caused, by traffic or the Contractor's

operations, to the foundation, roadway or sidewalk embankment or subgrade, in the opinion of the Engineer, shall be remedied by the Contractor at his/her sole expense, as directed by the Engineer.

The Contractor shall not use rubber-tired equipment on the foundation, roadway embankment, or subgrade, when its use causes, in the opinion of the Engineer, unnecessary damage to the foundation, road embankment or subgrade. The Contractor shall conduct his/her operations and provide the necessary equipment to ensure the satisfactory completion of the work without damaging the foundation, roadway embankment or subgrade. This may require the transporting and movement of materials over additional distances.

At various times throughout the work, the Engineer may direct the Contractor to use smaller and/or lighter equipment, and to defer certain work tasks, in order to protect the grade and/or adjacent areas. The Contractor shall not be entitled to an extension of time or any additional compensation for the use of smaller equipment, lighter equipment, or work task deferral.

j. Protection of Utilities.- Utility lines may become exposed at, above, or below, the foundation or subgrade elevation during machine grading or subgrade undercutting operations. If this occurs, the Contractor shall excavate around, above and/or below the utility lines, as directed, to complete the machine grading or subgrade undercutting operations. Payment, at contract unit prices, for “Machine Grading, Modified ___” or “Subgrade Undercutting, Type __,” whichever applies, will be considered as payment in full for this work.

k. Removal of Cable, Conduits and Pipe.- The Contractor shall remove, and properly dispose of off-site, all abandoned cables, conduit, and pipe encountered at, or above the bottom of any earthwork excavation or undercut. Where the inverts of abandoned, or to be abandoned or removed, conduits or pipe are less than 16 inches below the bottom of any earth excavation or undercut, the conduits and/or pipe shall be removed and the resulting void filled with an Engineer approved material. The fill material shall be compacted to 95% of its maximum unit weight in lifts not exceeding 12 inches. No separate payment will be made for removal of conduit or pipe, or any of the work, described in this section.

l. Foundation Preparation.- Foundation is defined as the original earth grade upon which roadway embankment is placed. The foundation work shall be completed in accordance with Section 205.03.A (Preparing Roadway Foundation) of the MDOT 2012 SSC as shown on the plans, and as specified herein.

The foundation shall be compacted to 95% of its maximum unit weight, as measured by the AASHTO T-180 method, to a depth of at least 10 inches. If this cannot be achieved, in the opinion of the Engineer, he/she will direct the Contractor to perform “Subgrade Undercutting, Type __” or as described herein, on the foundation.

m. Roadway Embankment Construction.- Roadway embankment is defined as the construction of earth on the prepared foundation to form the subgrade. Roadway embankment work shall be completed in accordance with Section 205.03 H (Roadway Embankment) of the MDOT 2012 SSC as shown on the plans, and as specified herein.

The backfill and backfilling behind curbs that have been removed and replaced shall be included in "Machine Grading, Modified ____". Sidewalk subgrade preparation is included in this pay item.

Roadway embankment shall be compacted to a minimum of 95% of its maximum unit weight, as measured by the AASHTO T-180 method.

n. Subgrade Construction.- Subgrade is defined as the final earth grade which extends from grading limit to grading limit. The subgrade shall be constructed by performing earth excavation and roadway embankment work in accordance with Section 205.03.G (Earth Excavation) and Section 205.03 H (Roadway Embankment) of the MDOT 2012 SSC, as shown on the plans, and as specified herein.

The subgrade shall be constructed to the contours and cross-sections shown on the plans, as specified herein, and as directed by the Engineer. To achieve this, the work shall include, but not be limited to:

1. Removal and disposal off-site of any surplus or unsuitable materials.
2. Furnishing from off-site any additional Engineer approved fill materials necessary.
3. Moving existing and/or furnished materials longitudinally and transversely as necessary.
4. Cutting, placing, compacting, and trimming existing and/or furnished materials to construct the roadway embankment and subgrade to the specified tolerances.
5. Stockpiling, and moving again, any cut materials which cannot be immediately placed upon excavation due to construction staging.

The subgrade shall be graded to accommodate all subbases and aggregate bases wherever used, all roadway pavements, curb and gutter, driveways, sidewalks, bicycle paths, other similar structures, topsoil and any other features which the subgrade supports.

The subgrade shall be prepared so as to ensure uniform support for the pavement structure. The finished subgrade shall be placed to within 1 inch below and $\frac{3}{4}$ inch above plan grade. Variations within this tolerance shall be gradual.

The subgrade shall be compacted to a minimum of 95% of its maximum unit weight, as measured by the AASHTO T-180 method, to a depth of 10 inches. If this cannot be achieved, in the opinion of the Engineer, he/she will direct the Contractor to perform "Subgrade Undercutting, Type ____" as described herein.

The Contractor shall use equipment and methods of construction best suited, in the opinion of the Engineer, to the earthwork operations being performed and the project requirements. The use of various equipment and methods of construction are subject to the approval of the Engineer. The Engineer may disallow the use of certain equipment and methods of construction and require the use of other equipment and/or methods of construction. No additional compensation or extensions of contract time will be allowed for additional measures that are required for the protection of the grade as specified herein.

All requirements of this special provision with regard to protection of the subgrade shall remain in full force if it is necessary to remove a sand subbase layer of insufficient thickness.

p. Test Rolling.- The Contractor shall test-roll the foundation and/or subgrade with a pneumatic tired roller with a suitable body for ballast loading and a gross load capacity that can be varied from 25 and 40 tons. In lieu of this test roller, with the approval of the Engineer, the Contractor may use a fully loaded single axle or tandem axle dump truck.

q. Subgrade Undercutting.- "Subgrade Undercutting, Type ___" shall be performed on the foundation or subgrade in accordance with Section 205.03.E (Subgrade Undercutting) of the MDOT 2012 SSC, as shown on the plans, as specified herein, and as directed by the Engineer.

r. Rock Excavation.- Rock excavation shall be performed in accordance with Section 205.03.B (Rock Excavation) of the MDOT 2012 SSC, as shown on the plans, and as directed by the Engineer.

The pay item "Rock Excavation" will apply only to boulders over $\frac{1}{2}$ cubic yard in volume. Boulders will be measured individually and the volume computed from the average dimension measured in three directions. The removal of rocks, concrete and masonry less than $\frac{1}{2}$ cubic yard in volume shall not be included in the pay item "Rock Excavation," but shall be included in the pay item "Machine Grading, Modified, ___."

If the proposal does not include a pay item for "Rock Excavation," rocks measuring over $\frac{1}{2}$ cubic yard in volume shall be paid for as extra work.

s. Lowering Structures.- Prior to cutting the subgrade, the Contractor shall remove structure covers, lower the structures to a point between 8 inches and 12 inches below the proposed subgrade, and cover the structures with a steel plate. Structures shall not be raised prior to placing roadway embankment.

The steel plates for covering structure openings shall conform to the plan detail, be pegged and properly placed to prevent their movement under all traffic, be thick enough to carry all traffic, and prevent the infiltration of debris into the structures.

The Contractor shall lower valve boxes to a point between 8 inches and 12 inches below the proposed subgrade. Valve boxes shall not be raised prior to placing roadway embankment.

The void in the grade above the steel plates used for structure lowerings and valve box lowerings shall be backfilled, and compacted to 95% of its maximum dry density, with an Engineer approved coarse aggregate.

“Machine Grading, Modified ____” shall include all the work associated with lowering structures, including backfilling.

The Contractor shall coordinate the lowering of private utility structures with the private utility companies.

t. Structure Covers.- As directed by the Engineer and within two days of their removal, the Contractor shall stockpile on-site, in a location that is mutually agreeable to the Engineer and Contractor, the existing structure covers. The City of Ann Arbor’s forces will pick-up the structure covers at a time that is convenient to them and mutually agreeable to the Contractor. The Contractor shall provide the equipment and manpower to load the castings on the City’s vehicle(s) so that they can be removed from the site by the City.

u. Structure and Sewer Cleanliness.- All sewers, and structures, including manholes, gate wells, valve boxes, inlet structures and curbs shall be protected from damage and contamination by debris and construction materials. Structures shall be maintained clean of construction debris and properly covered at all times during the construction. The Contractor shall immediately clean any structures and/or sewers that become contaminated with construction debris. The Contractor shall be responsible for all direct and indirect damages which are caused by sewers or structures which have been made unclean or have been damaged by the Contractor.

v. Contractor’s Calculations.- The Contractor shall perform his/her own computations and is responsible to inspect the site to determine his/her own estimate of the quantities of work involved. Deviations between the existing contours and the existing and proposed cross-sections shown on the plans shall not be cause for additional compensation.

w. Measurement and Payment.- The completed work as measured will be paid for at the contract unit price for the following contract items (pay items):

<u>Contract Item (Pay Item)</u>	<u>Pay Unit</u>
Item 238: Machine Grading, Modified, _____	Station

Subsection 205.04.G of the MDOT 2012 SSC, which reads “Machine Grading will be measured by length along the surface edge. The Engineer will measure each side of the

road, where work is performed, separately.” is hereby deleted. “Machine Grading, Modified, ____” will be measured once, and only once, along the centerline of the roadway or feature being constructed.

“Machine Grading, Modified, ____” will be measured by length in 100 foot long stations, or portions thereof, along the centerline of the road.

The various pay items included herein shall include all labor, materials and equipment required to complete the work.

The Contractor shall include all of his/her costs to complete all of the Machine Grading, Modified work in the Machine Grading, Modified pay items and plan quantities included in the proposal. No additional payment will be made for Machine Grading, Modified work which, although, shown on the plans and specified herein as work which needs to be completed, may not be included in a particular Machine Grading, Modified pay item. Plan quantities will be paid for the work, and will only be adjusted due to changes in the limits of the work, as directed by the Engineer, in writing.

The pay item “Machine Grading, Modified, _____” shall include all the work specified herein, including, but not limited to, the removal and offsite disposal of any surplus or unsuitable materials and the furnishing from off-site any additional Engineer approved fill materials necessary to construct the embankment and subgrade to the contours and cross-sections shown on the plans.

The Contractor is advised that due to the phasing of the project and the probable unsuitability of some or all of the excavated material for use as approved fill material, there may be imbalances between the amount of earth cut which is suitable for reuse as fill, and the amount of earth needed to construct the lines and grades shown on the plans, or as directed by the Engineer. The Contractor shall make provisions for such imbalances and shall include in the bid price for this work the cost of importing/furnishing, placement, and compaction of the material, as well as the cost of stockpiling and re-handling of imported and/or on-site Engineer approved materials as necessary to complete the work of constructing the embankment and subgrade to the cross sections shown on the plans.

CITY OF ANN ARBOR
DETAILED SPECIFICATION
FOR
SUBGRADE UNDERCUTTING

WT:VCM

1 of 1

01/17/19

a. Description. This work shall include the removal of unsuitable subgrade material(s) which may be susceptible to frost heaving or differential frost action in the areas and limits identified by the Engineer, and backfilling to replace these material(s) and remedy unstable soil conditions. This work shall be done in accordance with section 205 of the Michigan Department of Transportation (MDOT) 2012 Standard Specifications for Construction, as directed by the Engineer, and as modified herein.

b. Materials. Provide materials in accordance with Granular Material Class II and 21AA dense-graded aggregate as specified in section 902 of the MDOT 2012 Standard Specifications for Construction.

c. Construction. Construction methods shall be as described in subsection 205.03.E of the Standard Specifications for Construction, and as directed by the Engineer.

After the pavement has been removed, and/or after rough/finish grading, and/or at the time of proof rolling, the Engineer may inspect the grade to determine the need for, and the limits of, undercuts. After undercut areas are excavated to the depths as directed by the Engineer, the areas shall be trimmed, shaped, evenly graded and re-compacted to not less than 95% of the soils maximum unit weight as determined by the AASHTO T-180 test. The Contractor shall properly dispose of all excess materials.

Backfill areas of Subgrade Undercutting, Type IIB with Granular Material Class II or such other such material as directed by the Engineer.

d. Measurement and Payment. The completed work, as described, will be measured and paid for at the contract unit price for the following pay item:

<u>Pay Item</u>	<u>Pay Unit</u>
Item 241: Subgrade Undercutting, Type IIB.....	Cubic Yard

Basis of payment shall be as described in subsection 205.04 of the Standard Specifications for Construction except as herein modified.

CITY OF ANN ARBOR
 DETAILED SPECIFICATION
 FOR
STRUCTURE COVERS

WT:VCM

1 of 2

01/23/19

a. Description.- This work shall consist of furnishing structure covers as detailed on the plans and as specified herein.

<u>Type of Casting</u>	<u>MDOT Designation</u>	<u>Approx. Weight (lb)</u>	<u>East Jordan Iron Works Casting No.</u>	<u>Neenah Foundry Casting No.</u>
Manhole Flange and Cover	B	400 LB	1040 w/ 1040A cover*	R-1642 w/ Type C cover*
Manhole Flange and Cover, Sanitary	Q	400 LB	1040 w/ 1040AGS cover*	R-1642 w/ Type C cover*
Barrier Curb Round Flange	K	500 LB	7045 w/ Type M2 grate	R-3031-B w/ Type S grate
Barrier Curb Double Inlet Round Flange	K	500 LB	7045 w/ Type M2 grate	R-3031-B w/ Type S grate
Gutter Inlet Round Flange	R	500 LB	7076 w/ Type M1 grate	R-3594w/ Type S grate
Gutter Double Inlet	R	N/A	N/A	N/A
Yard Drain (Bee Hive)	G	200 LB	1040, Type 02 grate	R-2560-E1
Operating Nut Access Frame and Cover	1-A	200 LB	1570Z, 2965A Cover	Equivalent (as approved)

*Frames and covers shall have machined bearing surfaces and City of Ann Arbor custom logo. Each cover shall have the word "SANITARY", "STORM", "WATER", or a raised letter "W" cast in the surface, whichever is applicable.

b. Materials.- The materials used for this work shall conform to Section 908.05 of the Michigan Department of Transportation 2012 Standard Specifications for Construction except as specified herein.

c. Construction Methods.- This work shall be in accordance with Section 403 of the Michigan Department of Transportation 2012 Standard Specifications for Construction, design specifications, plans, and as specified in the related items of work for which the structure covers are provided, and except as modified herein. This work includes the removal, salvaging and transporting the existing casting and/or cover to the City Yard; and backfilling to grade per design specifications, plans, and as directed by the Engineer. .

d. Measurement and Payment.- The completed work as measured shall be paid at the contract unit price for the following contract items (pay items):

<u>(Contract Item) Pay Item</u>	<u>Pay Unit</u>
Item 242: Structure Covers, Special.....	Pounds

Payment for this item of work shall include all labor, materials and equipment needed to furnish and install the structure cover.

CITY OF ANN ARBOR
DETAILED SPECIFICATION
FOR
SUBGRADE UNDERDRAIN

WT:VCM

1 of 2

01/17/19

a. Description. The work shall include installing 6-inch geotextile-wrapped perforated or slotted underdrain in accordance with attached detail, as shown on the plans, as described herein, and as directed by the Engineer.

b. Material. The materials shall meet the requirements specified in section 404 of the Michigan Department of Transportation (MDOT) 2012 Standard Specifications for Construction, and as specified herein:

Fine Aggregate, 2NS	902
Underdrain Pipe, Perforated or Slotted.....	909.07.B

Geotextile (Filter Fabric) - The geotextile fabric for encasing the pipe shall be an approved material such as nylon, polypropylene, fiberglass, or polyester and shall be either woven, heat bonded, knitted or of continuous fibers. The geotextile shall completely cover and be secured to the pipe. In an unstretched condition, knitted polyester fabrics shall weight at least 3.0 ounces per square yard and all other geotextiles shall weigh at least 3.5 ounces per square yard. The fabric shall be strong and tough and have porosity such that the fabric will retain soil particles larger than 0.106 mm (No. 140 sieve) and shall pass aggregate particles finer than 0.025 mm. Geotextiles shall be stored and handled carefully and in accordance with the manufacturer's recommendations and shall not be exposed to heat or direct sunlight to such extent as to significantly affect its strength or toughness. Torn or punctured geotextiles shall not be used.

c. Construction Methods. Geotextile-wrapped underdrain for subgrade drainage shall be installed as shown on the plans and as specified in section 404 of the 2012 MDOT Standard Specifications for Construction, with the following exceptions and additions:

1. The trench shall be constructed to have a minimum width of 18 inches and the underdrain shall be installed at the line grade and depth as indicated on the plans. The contractor shall maintain line and grade by means of a laser. The Engineer will not set line, grade or provide staking.
2. The trench shall then be backfilled with 2NS Fine Aggregate compacted to 95% of its maximum unit weight. The first lift of backfill material shall be placed at a maximum thickness of 6 inches. The second and subsequent lifts, or portions thereof, shall be placed at a maximum thickness of 12 inches up to an elevation level with the bottom of the existing aggregate base course, or as directed by the Engineer.

3. Upgrade ends of the pipe shall be closed with suitable plugs to prevent entrance of any material. All couplings, tees and other fitting shall be manufactured and installed so as to prevent infiltration of any material. If during the course of construction, existing edge drains are encountered; their ends shall be plugged to the satisfaction of the Engineer such that material can not enter the pipe(s).
4. Downgrade ends of the pipe shall generally be tapped into existing or new drainage structures. However, it may be necessary to tap underdrain into either existing or new storm sewer, or into existing or new inlet leads as directed by the Engineer.
5. The trench bottom and edge drain shall be constructed to the percent of grade indicated on the plans or as determined by the Engineer, with the minimum percent of grade being 0.5%. In addition, the underdrain shall be constructed to have a minimum cover, from top of pipe to finished pavement grade, of 36 inches.
6. During the construction of underdrain runs, it may be necessary to terminate construction due to conflicts with buried obstructions or at such time when the minimum cover is reached. The Engineer will review conflicts on a case by case basis and make a decision on whether to continue installing pipe or terminate runs prematurely. The Contract unit price will not be adjusted or additional payments made, for changes in the contract quantity due to Engineer ordered field changes associated when buried obstructions are encountered.

d. Measurement and Payment. The completed work, as described, will be measured and paid for at the contract unit price for the following pay item:

<u>Pay Item</u>	<u>Pay Unit</u>
Item 243: 6 inch, Wrapped Underdrain.....	Foot

6 inch, Wrapped Underdrain will be measured in length by feet and will be paid for at the contract unit price, which price shall be payment in full for all labor, equipment and material needed to accomplish this work.

The unit price shall include the cost of the 6-inch perforated or slotted pipe, geotextile wrap, pipe fittings and/or plugs, 2NS granular bedding material, compaction and trench backfill, taps to new and existing drainage structures and storm sewers or inlet leads, all excavation, final trimming required to meet the dimensions of the typical and specific cross-sections, and the disposal of all surplus excavated materials.

CITY OF ANN ARBOR
DETAILED SPECIFICATION
FOR
SUBBASE AND AGGREGATE BASE

WT:VCM

1 of 2

01/17/19

a. Description.- This work shall consist of constructing subbase and/or aggregate base courses, on either a prepared subgrade or subbase as indicated on the Plans or where directed by the Engineer. This work shall be performed in accordance with Sections 301, 302, and 307 of the 2012 MDOT Standard Specification for Construction except as specified herein.

b. Materials.- The material used for this work shall meet the requirements of Sections 301, 302, 307, and 902 of MDOT 2012 Standard Specification for Construction, except that the aggregate base shall be either 21AA limestone (permanent and temporary applications) with a maximum loss by washing of 8% and any subbase shall be Class II Granular Material.

c. Construction Method.- Subbase and aggregate base courses shall not be placed when there are indications that the mixture may become frozen before the maximum unit weight is obtained, and in no case shall they be placed on a frozen subbase or subgrade.

The subbase and subgrade shall be shaped to the crown and grade specified on the plans and maintained in a smooth condition. The top of the subbase shall be placed to within ½ inch below and ½ inch above plan grade. The top of the aggregate base shall be placed to within ½ inch below and ¼ inch above plan grade. Variations within this tolerance shall be gradual. If in the opinion of the Engineer, the Contractor's equipment is causing or will cause any ruts in or damage to the subbase or subgrade, the equipment shall not be permitted on the subbase or subgrade.

Should the subgrade, subbase or aggregate base become damaged due to the Contractor's equipment or by local traffic, the subgrade, subbase, or aggregate base course shall be restored to the condition required by the Specifications without additional compensation to the Contractor.

No pavement course, concrete curb and gutter, or concrete driveway opening shall be placed until the subbase has been compacted to not less than 95 percent, and aggregate base course to not less than 98 percent of their respective maximum dry densities and until a "Permit to Place" has been issued by the Engineer.

Base course aggregate shall be handled and/or stockpiled on-site in a manner that minimizes segregation. Base course aggregate shall be deposited from trucks or through a spreader in a manner that will minimize segregation of material and that is approved by the Engineer. The re-handling of base course aggregate by the Contractor will not be considered sufficient cause to allow the material to become segregated. The Contractor may be required to wet the materials prior to and/or during placement to minimize segregation and to aid in compaction of the material should it be necessary.

All structures, including manholes, valve boxes, inlet structures and curbs shall be protected from damage and contamination by debris and construction materials. Structures shall be maintained clean of construction debris and properly covered at all times during the construction.

The Contractor may be charged for the cleaning by others of accumulated construction debris in the utility structures, and damages resulting from the uncleaned structures.

d. Measurement and Payment.- The completed work as measured will be paid for at the contract unit prices for the following contract items (pay items):

<u>Contract Item (Pay Item)</u>	<u>Pay Unit</u>
Item 244: Aggregate Base Course, 21AA, Modified	Ton

“Aggregate Base Course, 21AA, Modified” will be measured by weight in tons by certified delivery tickets submitted at the time of delivery to the project site. The item of work will be paid for at the contract unit price, which shall be payment in full for all labor, material and equipment needed to accomplish this work.

The provisions of Section 306.04 regarding excess moisture content, moisture corrections, and pay weights shall apply to this item of work.

CITY OF ANN ARBOR
DETAILED SPECIFICATION
FOR
MAINTENANCE GRAVEL, 21AA, MODIFIED

WT:VCM

1 of 2

01/17/19

a. Description.- This work shall consist of constructing temporary Maintenance Gravel on either a prepared subgrade or an existing aggregate surface as indicated on the Plans or where directed by the Engineer. This work shall be performed in accordance with Sections 306 of the 2012 MDOT Standard Specification for Construction except as specified herein.

b. Materials.- The material used for this work shall meet the requirements of Section 902 of MDOT 2012 Standard Specification for Construction, except that the Maintenance Gravel shall be 21AA.

c. Construction Method.- Perform the work in accordance with the requirements of Section 306 of the 2012 MDOT Standard Specification for Construction except as specified herein.

The Contractor shall blade and/or scarify and blade the existing aggregate surface in order to remove existing irregularities within the grade prior to placing the Maintenance Gravel material.

The material shall be handled and/or stockpiled in a manner that minimizes segregation. Maintenance Gravel aggregate shall be deposited from trucks or through a spreader in a manner that will minimize segregation of material and that is approved by the Engineer. The re-handling of the aggregate by the Contractor will not be considered sufficient cause to allow the material to become segregated. The Contractor may be required to wet the materials prior to and/or during placement to minimize segregation and to aid in compaction of the material should it be necessary.

All structures, including manholes, valve boxes, inlet structures and curbs shall be protected from damage and contamination by debris and construction materials. Structures shall be maintained clean of construction debris and properly covered at all times during the construction.

The Contractor may be charged for the cleaning by others of accumulated construction debris in the utility structures, and damages resulting from the uncleaned structures.

d. Measurement and Payment.- The completed work as measured will be paid for at the contract unit prices for the following contract items (pay items):

<u>Contract Item (Pay Item)</u>	<u>Pay Unit</u>
Item 245: Maintenance Gravel, 21AA, Modified	Ton

"Maintenance Gravel, 21AA, Modified" will be measured by weight in tons by certified delivery tickets submitted at the time of delivery. The item of work will be paid for at the contract unit price, which shall be payment in full for all labor, material and equipment needed to accomplish this work.

The provisions of Section 306.04 regarding excess moisture content, moisture corrections, and pay weights shall apply to this item of work.

CITY OF ANN ARBOR
 DETAILED SPECIFICATION
 FOR
FLOWABLE FILL

WT:VCM

1 of 2

01/17/19

a. Description. This work consists of furnishing and placing flowable fill as backfill material at miscellaneous locations as shown on the plans, and as directed by the Engineer.

b. Materials. Provide flowable fill material, as directed by the Engineer, meeting one the following mixes:

1. Portland cement, fly ash, and water.
2. Portland cement, granular material, fly ash, and water.
3. Fly ash, granular material, and water.

Provide materials in accordance with the following requirements:

		⁽³⁾ <u>Specific Gravity</u>
Portland Cement	MDOT Section 901	3.15
Fly Ash	⁽¹⁾ ASTM C 618(I)	2.40
Granular Material, CI II	⁽²⁾ MDOT Section 902	2.60
Water	MDOT Section 911	1.00

Note: Reference to MDOT relates to applicable sections of the Michigan Department of Transportation 2012 Standard Specifications for Construction.

⁽¹⁾Except there is no limit on the loss of ignition.

⁽²⁾Except that 100% shall pass 3/4-inch sieve.

⁽³⁾Specific gravity values used for mix proportions given. If material used differs from these values make appropriate adjustments as required to achieve an acceptable mixture.

Acceptable mixtures for flowable fill are as follows:

1. FF Mix Number One
 Cement Stabilized Fly Ash Mixture (Class F Fly Ash)

Portland Cement	100 lbs/cyd
Fly Ash (Class F)	2000 lbs/cyd
Water	Sufficient amounts to produce the desired flowability (approx. 80 gal/cyd)

2. FF Mix Number Two
 Controlled Density Fill Mixture (Class F Fly Ash)

Portland Cement	50 lbs/cyd
Fly Ash (Class F)	500 lbs/cyd
Granular Material	2600 lbs/cyd
Water	Sufficient amounts to produce the desired flowability (approx. 50 gal/cyd)

3. FF Mix Number Three
Controlled Density Fill Mixture (Class C Fly Ash)

Fly Ash (Class C)	300 lbs/cyd
Granular Material	2600 lbs/cyd
Water	Sufficient amounts to produce the desired flowability (approx. 50 gal/cyd)

c. Construction. Furnish and place flowable fill at miscellaneous locations as shown on the plans, and as directed by the Engineer.

All flowable fill, after setting, is intended to be removable by conventional mechanical excavation methods.

d. Measurement and Payment. The completed work, as described, will be measured and paid for at the contract unit prices for the following pay items:

<u>Pay Item</u>	<u>Pay Unit</u>
Item 246: Flowable Fill (Backfill)	Cubic Yard

The unit price for this item of work shall include all labor, material, and equipment costs to perform all the work specified by this Detailed Specification.

Flowable fill used at the Contractor's option will not be paid for separately but shall be included either in the bid price(s) for the associated work item(s), or in the bid price for the item of work "General Conditions, Max \$____".

CITY OF ANN ARBOR
DETAILED SPECIFICATION
FOR
CONCRETE PLACEMENT AND PROTECTION

WT:VCM

1 of 2

01/17/19

a. Description. This work shall consist of furnishing all labor, material, and equipment needed to furnish, place, and protect all concrete material in accordance with the requirements of this special provision.

b. Materials. The concrete shall meet the requirements of sections 601 and 701 of the Michigan Department of Transportation (MDOT) 2012 Standard Specifications for Construction.

The Contractor shall propose specific concrete mix designs for the intended project purpose in accordance with the requirements of this special provision and other applicable special provisions and/or project requirements. The Engineer's acceptance of a mix design shall not relieve the Contractor of their responsibility for the manufacture of the concrete mixture(s), its placement, or performance.

c. Construction. The Contractor shall perform all concrete placement operations in weather that is suitable for the successful placement and curing of the concrete materials. Concrete shall not be placed during periods of active precipitation.

The Contractor shall complete all needed formwork, base and/or sub-base preparation, and any other related items that are deemed necessary for the proper completion of the work. The Contractor shall not commence the placement of concrete until they receive all needed approvals from the Engineer for placement. The Engineer's approval of the Contractor to place concrete shall not relieve the Contractor of their responsibility for the proper placement and protection of the concrete materials or its long-term performance.

During periods when precipitation is threatening, provide durable, plastic sheeting, approved by the Engineer, in sufficient quantity to cover and protect all freshly placed concrete such that precipitation does not come into contact with the concrete. The Contractor shall arrange the placement of the plastic sheeting such that the surface of any freshly placed concrete is not marred by contact with the plastic; any seams in the plastic sheeting shall be water tight. The Contractor shall place adequate supports along and over the freshly placed concrete to prevent contact of the plastic and concrete. The Contractor shall ensure that sufficient dams or barriers are placed along the edges of the freshly placed concrete to prevent erosion of the underlying materials or damage to the edges of the freshly placed concrete. All measures shall be effective.

Any concrete damaged by precipitation shall be removed and replaced at the Contractor's expense. The Engineer shall decide if the concrete has been damaged and the limits of removal and replacement.

Concrete shall only be placed when the rate of surface evaporation at the site is less than 0.20 pounds per square foot per hour, according to figure 706-1 of the MDOT 2012

Standard Specifications for Construction. The Contractor shall provide approved equipment for determining the relative humidity and wind velocity at the site.

Water shall not be added to the placed concrete in order to aid finishing. Any water added to the concrete for slump adjustments shall be done by adding water to the mixing unit and thoroughly re-mixing the concrete for 30 revolutions of the mixing unit at mixing speed. Water shall not be added such that the design water-to-cement ratio of the concrete mixture or the design slump of the concrete mix is exceeded.

Concrete curing shall be performed in accordance with subsection 602.03.M of the MDOT 2012 Standard Specifications for Construction. Curing operations shall take precedence over texturing operations and continued concrete placement. All curing compound applied shall provide uniform coverage over the entire surface being protected. The placement of curing compound shall be free of spots, blotches, or uncovered or non-uniformly covered areas. Should any areas be determined to exist by the Engineer, the curing compound shall be immediately re-applied by the Contractor at no additional cost to the project.

The Contractor shall take all precautions when placing concrete to protect it from damage due to the elements. Concrete shall not be placed during precipitation events.

Concrete shall be protected from weather and temperature according to the requirements of subsection 602.03.T MDOT 2012 Standard Specifications for Construction. Concrete shall not be placed when the temperature of the plastic concrete mixture itself is greater than 90° F. In conditions where low temperature protection is required, the Contractor shall cover the concrete with insulated blankets, or other means as approved by the Engineer, to protect the concrete from damage. The concrete shall remain protected until it has reached a compressive strength of at least 1000 psi, or as directed by the Engineer.

d. Measurement and Payment. All costs associated with the conformance to the requirements of this Special Provision will not be paid for separately but shall be considered to be included in the respective items of work.

CITY OF ANN ARBOR
DETAILED SPECIFICATION
FOR
CONCRETE CURB AND DRIVEWAY OPENINGS

WT:VCM

1 of 2

01/17/19

a. Description.- This work shall consist of constructing concrete curb and gutter, and concrete curb openings in accordance with Section 802 of the MDOT 2012 Standard Specifications for Construction, as shown on the plans, and as specified herein.

b. Materials.- The materials shall meet the requirements as specified in Section 802.02 of the 2012 MDOT Standard Specifications and as specified herein:

Driveway Opening, Conc., Detail M, P-NC shall be Grade P-NC Concrete (658 lbs/cyd cement content). Driveway Opening, Conc, Detail L, P1 shall be Grade P1 Concrete (526 lbs/cyd cement content.). All concrete mixtures shall be made with 6AA coarse aggregate.

All other concrete curb and gutter specified herein shall be grade P1 with 6AA coarse aggregate. The Contractor may elect to add GGBFS to P1 mixtures in accordance with the requirements of the contract documents. No additional payment will be made for concrete mixtures containing GGBFS.

All concrete mixtures shall contain 6AA coarse aggregates which are either natural or limestone and meet the requirements of Section 902.

It shall be the Contractor's sole responsibility to propose specific concrete mix designs which meet the requirements of this Special Provision and the contract documents.

c. Construction Methods.- Curb and Gutter, Conc, AA Det SD-R-1 Special, shall be constructed as shown in the City of Ann Arbor Standard Details, Series R.

All driveway openings shall be constructed in accordance with MDOT Standard Detail R-29 (latest edition) for Concrete Driveway Openings, Details "L" and "M."

Expansion joints of the thickness shown on the details shall be placed as directed by the Engineer.

The preparation of the subbase or aggregate base course upon which the curb and gutter and drive openings are to be constructed shall be performed in accordance with the Special Provision entitled "Subbase and Aggregate Base". Sand subbase were required shall not be paid for separately but shall be included in the cost for the curb and gutter or driveway opening.

The concrete curb and gutter and/or driveway openings shall not be constructed on a pedestal or a mound. The subbase or aggregate base course shall be constructed

the full width of the stage or phase in which concrete curb and gutter or driveway opening is to be constructed.

The concrete items being placed shall not be opened to construction or vehicular traffic until such time as the concrete has reached the required flexural strength. The Contractor shall cast beams in accordance with Section 603.03.B.10, and as approved by the Engineer, and obtain concrete flexural strength in accordance with the requirements of Section 104.11, Table 104-2. Beams cast for open to traffic determinations shall be cured in the same manner and environment as the concrete items which they represent.

Flexural strength beams shall be tested (broken) with a device meeting the approval of the Engineer and be in a state of good repair and shall be calibrated by an accredited testing laboratory or engineering company within a period of two years from the date of the test being performed.

d. Measurement and Payment.- The completed work as measured shall be paid for at the contract unit price for the following contract items (pay items):

<u>Contract Item (Pay Item)</u>	<u>Pay Unit</u>
Item 250: Curb and Gutter, Conc, Match Existing, Special.....	Foot
Item 251: Curb and Gutter, Conc, AA Det SD-R-1, Special	Foot
Item 252: Driveway Opening, Conc, Detail M, P-NC	Foot

The pay items will be measured in length by the foot and will be payment in full for all labor, equipment and material needed to properly complete this work.

At curb openings for sidewalk ramps, the concrete curb and gutter (without the curb face) will be measured and paid for at the contact unit price for curb and gutter.

Driveway Opening, Conc, Detail L, P 1 shall not be paid for separately, but shall be included in the concrete curb and gutter or concrete pavement with integral curb pay items.

Where the Engineer directs the use of high early strength concrete for pay items that are not designated as "P-NC," the additional cement shall be paid for separately. No additional payment will be made for cement for pay items that are designated "P-NC."

CITY OF ANN ARBOR
SPECIAL PROVISION
FOR
CONCRETE SIDEWALK, ADA RAMPS, AND DRIVEWAY APPROACHES

WT:VCM

1 of 3

01/17/19

a. Description.- This work shall consist of constructing concrete sidewalk, ramp, or drive approaches of the types as indicated on the plan sheets, as detailed in the specifications, or as directed by the Engineer. It shall also include constructing concrete drive approaches of the types as indicated on the plan sheets, as detailed in the specifications, or as directed by the Engineer. All work shall be in accordance with Section 801 and 803 of the 2012 MDOT Standard Specifications for Construction and as specified herein.

All ADA ramps shall be installed with detectable warning units. Reference the Special Provision entitled "Detectable Warning Tiles" for additional requirements.

b. Materials.- The materials shall meet the requirements as specified in the 2012 MDOT Standard Specifications and as required herein. The grade of concrete for items designated as "P-NC" shall be Grade P-NC concrete (658 lbs/yd³ cement content) as specified in Section 601 of the 2012 MDOT Standard Specifications.

Concrete mix for "Sidewalk, Concrete, ___ inch, S2 Special" shall Include synthetic microfiber reinforcement in the concrete mixtures. Fibers shall be non-reactive, compatible with the concrete mix, and not be detectable in the finished surface, as determined by the Engineer. Fibers shall be 3/4" multifilament polypropylene and shall contain no less than 50 million individual fibers per pound. Required dosage rate shall be 1 pound per cubic yard of concrete, or as recommended by the manufacturer. The fiber shall comply with ASTM Designation C1116 Type III 4.1.3 and be used in accordance with ASTM C94.

The grade of concrete for all remaining items covered by this Special Provision shall be grade P1 as specified in Section 601 of the 2012 MDOT Standard Specifications for Construction. The Contractor may elect to add GGBFS to P1 mixtures in accordance with the requirements of the contract documents. No additional payment will be made for concrete mixtures containing GGBFS.

All concrete mixtures shall contain 6AA coarse aggregates which are either natural or limestone and meet the requirements of Section 902 of the 2012 Michigan Department of Transportation Standard Specifications for Construction.

It shall be the Contractor's sole responsibility to propose specific concrete mix designs which meet the requirements of this Special Provision.

c. Construction Methods.- The Contractor is responsible to construct all sidewalk, sidewalk ramps, curbs, and all other concrete items within ADAAG compliance. All sidewalk and curb ramps must be constructed in accordance with MDOT Standard Detail R-28 (latest edition).

Where concrete sidewalk and/or ADA compliant ramps are to be placed, they shall be placed on a minimum of 4 inch sand subbase consisting of Granular Material, Class II, compacted to 95% of its maximum dry density. Sand subbase shall not be paid for separately but shall be included in the cost for the sidewalk or sidewalk ramp.

Concrete drive approaches shall be placed on either aggregate base course or a sand sub-base as shown on the plans or as directed by the Engineer. The required density of the material underlying the concrete drive approach shall be that of the material on which it is placed and required by those specifications. Sand subbase were required shall not be paid for separately but shall be included in the cost for the drive approach.

Prior to placing any concrete, the subgrade shall be completed and trimmed to final elevation. If a cold joint is required, the existing concrete is to be cleaned with compressed air to expose the aggregate in the concrete.

Where indicated on the plans to be performed, the Contractor shall also horizontally sawcut curbs to provide openings for sidewalk ramps as indicated. The Engineer shall define the extent of sawcutting both horizontally and vertically. This work will not be paid for separately, but shall be included in the corresponding price of the ADA ramp to be placed.

Where indicated on the plans to be performed, the Contractor shall provide monolithic rolled curbs or side flares along the longitudinal edges of the ramp, landing, sidewalk, and curb and gutter openings. The City will pay for rolled curb adjacent to the non-traffic edge of parallel or combination ramps separately, only if the required height exceeds 18 inches along a continuous run.

The concrete items being placed shall not be opened to construction or vehicular traffic until such time as the concrete has reached the required flexural strength. The Contractor shall cast beams in accordance with Section 603.03.B.10, and as approved by the Engineer, and obtain concrete flexural strength in accordance with the requirements of Section 104.11, Table 104-2. Beams cast for open to traffic determinations shall be cured in the same manner and environment as the concrete items which they represent.

Flexural strength beams shall be tested (broken) with a device meeting the approval of the Engineer and be in a state of good repair and shall be calibrated by an accredited testing laboratory or engineering company within a period of two years from the date of the test being performed.

All ADA ramps shall be installed with detectable warning units. Reference the Special Provision entitled "Detectable Warning Tiles" for additional requirements.

d. Measurement and Payment.- The completed work as measured for the following pay items will be paid for at the contract unit prices for the following contract items (pay items):

Contract Item (Pay Item)**Pay Unit**

Item 255: Sidewalk, Concrete, ___ inch, Special.....	Square Foot
Item 256: Sidewalk Ramp, Concrete, ___ inch, Special	Square Foot
Item 257: Sidewalk, Concrete, ___ inch, S2 Special	Square Foot
Item 258: Sidewalk Ramp, Concrete, ___ inch, S2 Special ...	Square Foot
Item 259: Drive Approach, Conc, ___ inch, Non-Reinf	Square Foot
Item 260: Drive Approach, Conc, ___ inch, Non-Reinf, P-NC	Square Foot

The above items will be measured by area in square feet and be paid for at their respective contract unit price, which price shall be payment in full for all labor, equipment and material needed to accomplish this work. The unit price shall also include all costs associated with sawcutting curbs to provide openings for ADA sidewalk ramps, and rolled curbs and side flares as indicated on the plans; and shall also include Granular Material CLII sand subbase.

Where the Engineer directs the use of high early concrete for pay items that are not designated as "P-NC," the additional cement shall be paid for separately. No additional payment will be made for cement for pay items that are designated "P-NC."

Excavation for placement of Granular Material, Class II, bedding material shall be included in the item of work "Machine Grading, Modified, ___" and shall not be paid for separately.

Detectable warning units cast in place, shall be paid for in accordance with the Detailed Specification for Detectable Warning Surface.

CITY OF ANN ARBOR
DETAILED SPECIFICATION
FOR
DETECTABLE WARNING SURFACE

WT:VCM

1 of 2

01/17/19

a. Description. This work shall consist of furnishing and installing cast in place detectable warning units in compliance to the Americans with Disabilities Act (ADA) Title 49 CFR Transportation, Part 37.9 Standards for Accessible Transportation Facilities, Appendix A, section 4.29.2 Detectable Warnings on Walking Surfaces. All work shall be in accordance with the Detailed Specification for “Concrete Sidewalk, ADA Ramps and Driveway Approaches, section 803 of the Michigan Department of Transportation (MODT) 2012 Standard Specifications for Construction, MDOT Standard Plan Series R-28, as indicated on the plans, and as modified herein.

b. Materials. The detectable warning tiles shall be colored as Federal Number 22144 (frequently referred to as “Colonial Red” or “Brick Red”).

American Society for Testing and Materials (ASTM) Test Methods B117, C1028, D543, D570, D638, D695, D790, D2486, D2565, D5420, and E84 will apply.

The detectable warning tiles shall meet the following material properties, dimensions, and tolerances using the most current test methods:

1. Water Absorption: Not to exceed 0.35% when tested in accordance with ASTM-D570
2. Slip Resistance: 0.80 minimum combined wet/dry static coefficient of friction on top domes and field area, when tested in accordance with ASTM C1028.
3. Compressive Strength: 18,000 psi minimum, when tested in accordance with ASTM D695.
4. Tensile Strength: 10,000 psi minimum, when tested in accordance with ASTM D638.
5. Flexural Strength: 24,000 psi minimum, when tested in accordance with ASTM D790.
6. Chemical Stain Resistance: No reaction to 1% hydrochloric acid, urine, chewing gum, soap solution, motor oil, bleach, calcium chloride, when tested in accordance with ASTM D543 or D1308.
7. Wear Depth: 300 minimum, when tested in accordance with ASTM C501.
8. Flame Spread: 25 maximum, when tested in accordance with ASTM E84.
9. Gardner Impact: 50 in.-lbs. minimum, when tested in accordance with Geometry “GE” of ASTM D5420.
10. Accelerated Weathering of Tile when tested by ASTM-G155 or ASTM G151 shall exhibit the following result- $\Delta E < 6.0$ as well as no deterioration, fading or chalking of surface when exposed to 3000 hours minimum exposure.
11. Wheel Loading: The cast in place tile shall be mounted on a concrete platform with a ½” airspace at the underside of the tile top plate then subjected to the

specified maximum load of 10,400 lbs., corresponding to an 8,000 lb individual wheel load and a 30% impact factor. The tile shall exhibit no visible damage at the maximum load of 10,400 lbs using AASHTO-HB17 single sheet HS20-44 loading "Standard Specifications for Highways and Bridges."

12. Salt and Spray Performance of Tile and Adhesive System when tested to ASTM-B117 not to show any deterioration or other defects after 100 hours of exposure

Submit manufacturer’s literature describing products, installation procedures and maintenance instructions. Provide cast-in-place detectable surface tiles and accessories as produced by a single manufacturer.

Samples for Verification Purposes: Submit two (2) tile samples minimum 6” x 8” of the kind proposed for use. Samples shall be properly labeled and shall contain the following information: Name of Project; Submitted by; Date of Submittal; Manufacture’s Name; Catalog No.; and Date of Fabrication.

Material Test Reports: Submit current test reports from a qualified, independent, testing laboratory indicating that materials proposed for use are in compliance with requirements and meet the properties indicated. The required tests listed elsewhere in this Special Provision shall be performed by a certified and qualified independent testing laboratory on a cast-in-place tactile warning system. All test reports submitted shall be certified by the testing laboratory and shall clearly state that all tests were completed within 5 years of the date of the submittal. The manufacturer shall certify in writing that the materials provided to the project are manufactured with the same materials and manufacturing procedures as those used in the materials on which the test were performed.

c. Construction. Installer’s Qualifications: Engage an experienced Installer who has successfully completed tile installations similar in material, design, and extent to that indicated for this Project.

The Contractor shall follow manufacturer specifications for installation, except where they conflict with MDOT Standard Plan Series R-28 (latest edition), or other project requirements.

d. Measurement and Payment. The completed work, as described, will be measured and paid for at the contract unit price for the following pay item:

<u>Pay Item</u>	<u>Pay Unit</u>
Item 261: Detectable Warning Surface, Modified	Foot

The unit price for this item shall include all labor, material, and equipment costs required to complete the work. Detectable Warning Surface is measured in linear feet a minimum 24-inches wide across the full width of the ramp.

CITY OF ANN ARBOR
DETAILED SPECIFICATION
FOR
REMOVAL AND REINSTALLATION OF CONCRETE OR CLAY BRICK PAVERS

WT:VCM

1 of 2

01/17/19

a. Description. This work consists of removing, stockpiling and reinstalling concrete, clay, brick or other type material, sidewalk pavers. Furnish and install sand base, concrete base, fine aggregate leveling bed, fine aggregate joint filler, and any additional brick pavers as shown on the plans, and as directed by the Engineer.

b. Materials.

Aggregate base, where required, shall consist of Dense-Graded Class 21AA Limestone in accordance with section 902 of the Michigan Department of Transportation 2012 Standard Specifications for Construction.

Sand base, where required, shall consist of Granular Material Class II in accordance with section 902 of the MDOT 2012 Standard Specifications for Construction.

Construct concrete base, where required, using Grade P1 or Grade P2 concrete in accordance with section 601 of the MDOT 2012 Standard Specifications for Construction.

Fine aggregate leveling bed shall consist of a 3:1 mix of Fine Aggregate 2NS (3 parts) and Type N Masonry Cement (1 part). Use Fine Aggregate 2MS as joint filler. Masonry cement and fine aggregate materials shall be in accordance with sections 901 and 902, respectively, of the MDOT 2012 Standard Specifications for Construction.

Any additional brick pavers required shall match the material and color of the existing brick pavers in the areas adjoining the removal/replacement limits.

c. Construction. The Contractor shall remove and salvage existing pavers, remove any existing mortar or bituminous setting bed and concrete base, to the limits specified by the Engineer, down to the existing aggregate base. Where an existing base is not present, the subbase shall be removed to a sufficient depth for construction of the proposed section as shown on the attached detail, or as directed by the Engineer. Salvaged pavers shall be stored on-site in an area approved by the Engineer until they are ready for use.

The Contractor shall shape, grade, and compact the existing base materials, and shall construct the base to match the existing adjacent elevations.

Blend fine aggregate and mortar uniformly to create the leveling bed mix. Place leveling bed on aggregate base or existing concrete base to match the existing depth of adjacent pavers, and as shown on the Plans. Use control bars and/or guides to screed the fine aggregate leveling bed.

Brick installation is to match the pattern of the existing adjacent brickwork. Use string lines or other devices as needed to insure straight joint lines and final surface elevations. Butt paving units tight to adjacent concrete paving and to each other. Protect newly laid

pavers at all times by plywood panels on which workers stand. Use a plate vibratory compactor (min. 5,000 lbs compaction force) and make a minimum of three (3) passes to set paving units in leveling course prior to filling joints. Protect pavers from chipping and cracking during compaction.

Spread fine aggregate joint filler over paver surface and broom into joints, and mist lightly with water to settle sand into joints. Allow to surface dry and repeat process, as required, to fill joints completely. Remove excess sand upon completion.

The Contractor shall take any necessary precautions to prevent damage to pavers during removal and replacement. The Contractor is not entitled to any additional compensation for such replacement of damaged pavers.

d. Measurement and Payment. The completed work, as described, will be measured and paid for at the contract unit prices for the following pay items:

Pay Item

Pay Unit

Item 263: Sidewalk, Conc or Clay Brick Pavers, Rem and Reinstall ...Square Foot

The unit price for this item of work shall include all labor, material, and equipment costs to perform all the work specified by this Detailed Specification.

CITY OF ANN ARBOR
DETAILED SPECIFICATION
FOR
HOT MIX ASHALT (HMA) PAVEMENT REPAIR

WT:VCM

1 of 1

01/23/19

a. Description. This work consists of cold milling the existing pavement, repairing areas of failed asphalt pavement, and placing new hot mix asphalt (HMA) material as directed by the Engineer and as described herein. Complete pavement repairs in the cold milled surface prior to placement of the first hot mix asphalt paving course.

b. Materials. Provide materials in accordance with subsection 501.02 of the MDOT 2012 Standard Specifications for Construction, detailed specifications and as shown on the plans.

c. Construction. Cold mill designated areas, repair pavement in locations as specified by the Engineer, and place "Hand Patching, Modified", in accordance with the details on the plans and according to subsection 501.03 of the MDOT 2012 Standard Specifications for Construction. The Engineer will designate repair locations after the pavement has been cold milled as shown on the plans. The milling machine must return to the designated repair locations to mill an additional depth of 3 inches. "Hand Patching, Modified" must be placed in the repair area and roller compacted prior to placement of the paving course.

d. Measurement and Payment. Measure and pay for the completed work, as described, at the respective contract unit prices using the following respective pay items:

Pay Item	Pay Unit
Item 264: Cold Milling HMA Surface, Modified	Square Yard
Item 265: Hand Patching, Modified.....	Ton

Measure **Cold Milling HMA Surface, Modified** area by the unit square yard and pay for it at the contract unit price, which price includes the cost for all labor, equipment and materials required to remove, load, haul, and dispose of the cold milled material, and cleaning the cold milled pavement. The Engineer will not pay for material picked up by cleaning after cold milling.

Measure **Hand Patching, Modified** weight by the unit ton and pay for it at the contract unit price, which prices includes the cost for all labor, equipment and materials to place HMA, by hand or other methods, the placement of bond coat, and compacting the material.

CITY OF ANN ARBOR
DETAILED SPECIFICATION
FOR
ACCEPTANCE OF HMA MIXTURES

WT:VCM

1 of 9

01/17/19

Description.- This special provision establishes sampling and testing acceptance criteria for HMA Mixtures placed on City of Ann Arbor projects. The HMA mixtures shall meet all the requirements of Section 501 of the MDOT 2012 Standard Specifications for Construction, except as modified herein.

a. Contractor Quality Control.- The Contractor must have a quality control plan as required by Section 501.03.M and as stipulated herein. The Quality Control (QC) Plan shall be submitted to the Engineer within 30 days of contract award or 14 days before the placement of any HMA materials, whichever date comes first. The QC Plan shall cover all aspects of HMA production, transportation, placement, and compaction. The Contractor shall have a QC representative on-site at all times during the paving operations to monitor and direct all paving-related operations. The placement of HMA shall not commence until such time as the QC Plan has been accepted by the Engineer. The Engineer's acceptance of the QC Plan shall not be construed as a basis of acceptance of any HMA materials, HMA placement results, or a waiver of any requirement(s) of the project specifications.

b. Materials.- Aggregates, mineral filler (if required), and asphalt binder shall be combined as necessary to produce a mixture proportioned within the specification requirements including aggregate gradation; the mix design criteria including volumetric properties; the Superpave Gyratory (SGC) compaction criteria; and the uniformity tolerances listed in Table 1. Topsoil, clay, or loam shall not be added to aggregates which are to be used in plant mixed HMA mixtures.

c. Mix Designs.- The Contractor shall submit mix designs for evaluation in accordance with the Michigan Department of Transportation Hot Mix Asphalt Production Manual. All mix designs shall be submitted for review a minimum of 3 weeks prior to the anticipated placement of the HMA. Do not begin production and placement of the HMA until receipt of the Engineer's approval of the JMF. The Contractor's production and paving schedules shall be considered to include the mix design review and approval process. Delays associated with the submittal, or re-submittal, of the required information shall not be a basis for an extension of contract time.

d. Construction.- Target air voids shall be 3.5% in leveling courses, top courses and shoulders paved in the same operation as the leveling and top courses. Target air voids shall be 3% in base courses and shoulders not paved in the same operation as the leveling and top courses. Pedestrian paths shall have a target air void content of 3%.

After the job-mix-formula (JMF) is established, the parameters identified in Table 1 shall be maintained within the Range 1 tolerance limits of Table 1. However, if deviations are predominately either below, or above, the JMF, the Engineer may order alterations in the plant to bring the mixture into better conformance with the JMF.

The mixture will be considered out-of-specification, as determined by the acceptance tests, if for any one mixture, two consecutive tests per parameter (for Parameter 6, two consecutive aggregate gradations on one sieve) are outside Range 1 or Range 2 tolerance limits. If a parameter is outside of Range 1 tolerance limits and the second consecutive test shows that the parameter is outside of Range 2, then it will be considered to be a Range 1 out-of-specification. Consecutive refers to the production order and not necessarily the testing order. Out-of-specification mixtures are subject to rejection per Section f. Rejected Mixtures or a price adjustment per Section g. Price Adjustments of this special provision as determined by the Engineer.

Contractor paving operations will be suspended when the mixture is determined to be out-of-specification. Contract time will continue during periods when paving operations are suspended or when dispute resolution testing and investigations are occurring. The Engineer may issue a Notice of Non-Compliance with Contract Requirements (Form 1165), if the Contractor has not suspended operations and taken corrective action. The Contractor shall submit a revised JMF or proposed alterations to the plant and/or materials to achieve the JMF to the Engineer. Effects on the Aggregate Wear Index (AWI) and mix design properties shall be taken into consideration. Production and placement of HMA material shall not resume until receipt of the Engineer's approval to proceed.

For production/mainline-type paving, obtain the minimum number of samples as shown in Table 2, each being 20,000 grams, each day of production, for each mix type. The Engineer will sample the HMA and maintain possession of each sample. Sampling from the paver hopper is prohibited. Each sample will be divided into two 10,000 gram halves with one half being used for initial testing and the other half being held for possible dispute resolution testing. Obtain a minimum of three samples for each mix type regardless of the number of days of production.

Ensure all persons performing Quality Control (QC) and Quality Assurance (QA) HMA field sampling are "Local Agency HMA Sampling Qualified" samplers. The Engineer shall obtain the QA samples from the hauling units in accordance with *MTM 313 (Sampling HMA Paving Mixtures.)* The samples shall be representative of the day's paving. Sample collection shall be spaced throughout the planned tonnage as directed by the Engineer. At a minimum, one sample will be obtained in the first half of the planned tonnage and, as a minimum, the second sample will be obtained in the second half of the tonnage. If planned paving is reduced or suspended, when paving resumes, the remaining sampling must be representative of the original intended sampling timing.

Samples shall be taken from separate loads as directed by the Engineer.

Ensure all persons performing testing are Bit Level One certified or Bit QA/QC Technician certified. Acceptance testing will be performed by the Engineer using the testing method selected by the Engineer. Quality control measures to ensure job control are the sole responsibility of the Contractor.

The test method for measuring asphalt content (AC) shall be *MTM 325 (Quantitative Extraction of Bitumen from HMA Paving Mixtures)*. Back calculations to determine AC content will not be allowed.

All labs performing local agency acceptance testing shall be qualified labs as defined in the *HMA Production Manual* and participate in the MDOT round robin process, or they must be *AASHTO Materials Reference Laboratory (AMRL)* accredited for *AASHTO T 30* or *T 27*, and *AASHTO T 164* or *T 308*. Independent testing labs must not have conflicts of interest with the Contractor or Local Agency. On non-National Highway System (NHS) routes, Contractor labs may be used, but they must be qualified labs as previously stated. The Contractor shall provide copies of this documentation to the Engineer for review a minimum of 21 calendar days prior to the performance of any paving operations on the project.

Contractor labs may not be used for acceptance testing on NHS routes.

Material acceptance testing will be completed by the Engineer within 5 calendar days, except holidays and Sundays, after the Engineer has obtained the samples. QA test results will be provided to the Contractor after the Engineer receives the QC test results. Failure on the part of the Engineer or the laboratory to provide Quality Assurance test results within the specified time frame does not relieve the Contractor of their responsibility to provide an asphalt mix within specifications. The Contractor's schedule shall be deemed to include these material testing timeframes.

For production/mainline-type paving, the mixture may be accepted by visual inspection up to a quantity of 250 tons per mixture type, per project (not per day). For non-production-type paving defined as driveways, approaches, and patching, visual inspection may be allowed regardless of the tonnage.

The crushed particle content of the aggregate used in the HMA mixture shall not be more than 10 percentage points above or below the crushed particle content used in the JMF, nor less than the minimum specified for the aggregates in the contract documents.

Pavement density will be measured by the Engineer with a nuclear density gauge using the G_{mm} from the JMF for the density control target. The required in-place density of the HMA shall be between 92.0 and 96.0 percent of the density control target. The Contractor is responsible for establishing a rolling pattern that will achieve the required in-place density. Should the specified target densities not be met, the material shall be considered to have a Range 2 failure and shall be rejected. If the Engineer determines that the material is suitable to remain in place, a 50% reduction to the base price of all material affected shall be enacted by the Engineer. Should the Engineer determine that the material cannot remain in place, the affected material will be removed and replaced at the Contractor's sole expense as detailed in the Section f. "Rejected Mixtures."

After placement, roll the HMA mixture as soon after placement as the roller is able to bear without undue displacement or cracking. Start rolling longitudinally at the sides of the lanes and proceed toward the center of the pavement, overlapping on successive

trips by at least half the width of the drum. Ensure each required roller is 8 tons minimum in weight unless otherwise approved by the Engineer.

Ensure the initial breakdown roller is capable of vibratory compaction and is a maximum of 500 feet behind the paving operations. The maximum allowable speed of each roller is 3 miles per hour (mph) or 4.5 feet per second. Ensure all compaction rollers complete a minimum of two complete rolling cycles prior to the mat temperature cooling to 180 degrees Fahrenheit (F). Continue finish rolling until all roller marks are eliminated and no further compaction is possible. The Engineer will verify and document that the roller pattern has been followed and density has been achieved. The Engineer can stop the placement of HMA when the roller pattern is not followed and density is not obtained. Contract time shall continue during this period and the Contractor shall be responsible for any additional costs incurred due to this work stoppage.

Pavement in-place density tests will be completed by the Engineer during paving operations and prior to traffic staging changes. Pavement in-place density acceptance testing will be completed by the Engineer prior to the Contractor being allowed to pave subsequent lifts of HMA or the newly placed HMA being opened to traffic.

HMA Acceptance Criteria
Table 1 – Uniformity Tolerance Limits for HMA
Mixtures

Parameter		Top and Leveling Courses		Base Course	
		*Range 1	Range 2	*Range 1	Range 2
Number	Description				
1	Air Voids	± 0.60	± 1.00	± 0.60	± 1.00
2	VMA	± 0.60	± 1.00	± 0.60	± 1.00
3	G_{mm} (maximum specific gravity of mixture)	± 0.013	± 0.020	± 0.013	± 0.020
4	Fines to Effective Binder Ratio (this parameter is independent of JMF)	0.6 to 1.2	0.6 to 1.4	0.6 to 1.2	0.6 to 1.4
5	Binder Content	± 0.30	± 0.40	± 0.30	± 0.40
6	Percent Passing No. 8 and Larger Sieves	± 5.0	± 8.0	± 7.0	± 9.0
	Percent Passing No. 30 Sieve	± 4.0	± 6.0	± 6.0	± 9.0

	Percent Passing No. 200 Sieve	± 1.0	± 2.0	± 2.0	± 3.0
7	Crushed Particle Content	Below 10%	Below 15%	Below 10%	Below 15%
*This range allows for normal mixture and testing variations. The mixture shall be proportioned to test as closely as possible to the Job-Mix-Formula.					

The tolerances specified in Table 1, with the exception of the Fines to Effective Binder Ratio, reflect variations from the approved job-mix formula.

Parameter Number 6 as shown in Table 1 is aggregate gradation. Each sieve will be evaluated on one of the three gradation tolerance categories. If more than one sieve is exceeding Range 1 or Range 2 tolerances, the sieve with the largest difference from the JMF will be counted as the gradation parameter. The master gradation should be maintained throughout production; however, price adjustments will be based on Table 1.

Extraction/gradation and volumetric tests will be performed by the Engineer to confirm conformance to the specifications and the tolerances identified in Table 1. The minimum number of samples to be obtained and tested shall be in accordance with Table 2.

Table 2 – Minimum Number of Samples

Quantity (tons) of Single Mixture Placed per Day	Minimum Number of Samples per Mixture per Day
<100	0
101 – 250	1
251 – 1,500	3
1,501 – 3,000	5
3,001 – 4,500	as directed by the Engineer

e. Rejected Mixtures.- If, for any one mixture, two consecutive tests per parameter (for Parameter 6, two consecutive aggregate gradations on one sieve) are outside Range 1 or Range 2 tolerance limits the mixture is considered out-of-specification and will be rejected. If a parameter is outside of Range 1 tolerance limits and the second consecutive test shows that the parameter is outside of Range 2, then it will be considered to be a Range 1 out-of-specification. If, for any one mixture, two consecutive tests do not meet the minimum requirements for crushed particle content specified in the project documents, the portion of the mixture with insufficient crushed particle content will be considered out-of-specification and will be rejected.

The quantity of material to be rejected is defined as the material produced from the time the first out-of-specification sample was taken until the time the sample leading to the first in-specification test was taken.

If out-of-specification mixtures are placed in a pavement, the Contractor has 4 calendar days from receipt of the acceptance test results to notify the Engineer, in writing, that dispute resolution testing is requested. The Contractor's QC test results for the corresponding QA test results must result in an overall payment greater than QA test results, otherwise the QA tests will not be allowed to be disputed. The Engineer has 4 calendar days to send the dispute resolution sample to the MDOT Central Laboratory once dispute resolution testing is requested. The remaining 10,000 gram portion of the field samples (split samples) will be sent to the Central Laboratory to complete all Dispute Resolution testing and return test results to the Engineer, who will provide them to the

Contractor, within 13 calendar days upon receiving the Dispute Resolution samples. The Contractor may only take pavement cores if approved in writing by the Engineer. If the Central Laboratory test results do not confirm the original field test results, then no price adjustments will be made for the mixture involved.

If the Central Laboratory test results confirm the original test results and, in the Engineer's judgment, the mixture warrants removal, the Contractor shall remove and replace the rejected (out-of-specification) mixture, at the Contractor's expense, with a mixture meeting the specification requirements. These costs shall be deemed to include all costs associated with the material removal and replacement including, but not limited to; costs associated with re-mobilization of labor and equipment; traffic control; removal and disposal of the rejected material; transportation costs to provide material meeting the requirements of the specification; and, any other cost associated with the work. Contract time shall continue during the period of time that the rejected material is investigated and re-tested, as well as, during the removal and replacement operations.

If the Central Laboratory test results confirm the original test results and, in the Engineer's judgment, the mixture can remain in place, the base and/or unit price for the rejected (out-of-specification) mixture will be decreased as described in the Section f., "Price Adjustments."

If no field extractions are performed on a given day because the quantity being placed is less than 100 tons, and if there is reason to believe that the mixture contains material parameters that exceed Range 2 tolerances, or if the crushed particle content is less than the established criteria, a price adjustment may also be applied, or removal may be required, based on extraction, gradation, and volumetric tests performed by the Engineer from pavement cores following the procedures outlined herein.

f. Price Adjustments.- Base Price. Price established by the Department to be used in calculating incentives and adjustments to pay items and shown in the contract.

Price adjustments for either Range 1 and/or Range 2 failures shall be made to the base and/or unit price of HMA material in accordance with the procedures outlined in the Special Provision 12TM501(A335) entitled "Hot Mix Asphalt Prices for Adjustments" for mixtures with failing test parameters.

The quantity of material receiving a price adjustment is defined as the material produced from the time the first out-of-specification sample was taken until the time the sample leading to the first in-specification test was taken.

The price adjustments will be determined by the Engineer from the combination of sample test result parameters of the out-of-specification (rejected) material that create the largest total price adjustment for the material. The price adjustments shall be determined based on Tables 3 and 4. The Engineer is not obligated to accept a price adjustment for out-of-specification (rejected) material that exceeds Range 2 limits in lieu of requiring the material to be removed and replaced at the Contractor's expense in accordance with Section f., Rejected Mixtures.

In all cases, when penalties are assessed, the penalty applies to each parameter, up to two parameters, that is out of specification.

Table 3: Penalty Per Parameter

Mixture Parameter out-of-Specification per Acceptance Tests	Mixture Parameter out-of-Specification per Dispute Resolution Test Lab	Price Adjustment per Parameter
NO	N/A	None
YES	NO	None
	YES	Outside Range 1 but not Range 2: decrease by 10%
		Outside Range 2: decrease by 25%

**Table 4
Calculating Total Price Adjustment**

Cost Adjustment as a Sum of the Highest Parameter Penalties		
Number of Samples with Parameters Out-of-Specification	Range(s) Outside of Tolerance Limits of Table 1 per Parameter	Total Price Adjustment
One	Range 1	10%
	Range 2	25%
Two	Range 1 & Range 1	20%
	Range 1 & Range 2	35%
	Range 2 & Range 2	50%
Three or more	Range 1, Range 1 & Range 1	20%
	Range 1, Range 1 & Range 2	35%
	Range 1, Range 2 & Range 2	50%
	Range 2, Range 2 & Range 2	50%

Each parameter of Table 1 is evaluated with the total price adjustment applied to the base and/or unit price based on a sum of the two parameter penalties resulting in the highest total price adjustment in accordance with Table 4. For example, if three parameters are out-of-specification, with two parameters outside Range 1 of Table 1 tolerance limits, but within Range 2 of Table 1 limits and one parameter outside of Range 2 of Table 1 tolerance limits and the Engineer approves leaving the mixture in place, the total price adjustment for that quantity of material is 35 percent.

If acceptance tests, as described in Section e. of this special provision, show that a Table 1 mixture parameter exceeds the Range 1, but not the Range 2, tolerance limits, that mixture parameter will be subject to a 10 percent penalty. The 10 percent penalty will be assessed based on the acceptance tests only unless the Contractor requests that the 10,000 gram sample part retained for possible dispute resolution testing be tested. The Contractor has 4 calendar days from receipt of the acceptance test results to notify the Engineer, in writing, that dispute resolution testing is requested. The Contractor's QC test results for the corresponding QA test results must result in an overall payment greater than QA test results, otherwise the QA tests will not be allowed to be disputed. The Engineer has 4 calendar days to send the dispute resolution sample to the MDOT Central Laboratory and the resultant dispute test results will be used to determine the penalty per parameter, if any. If the dispute testing results show that the mixture parameter is out-of-specification, the Contractor will pay for the cost of the dispute resolution testing and the contract unit and/or base price for the material will be adjusted, based on all test result parameters from the dispute tests, as shown in Table 3 and Table 4.

If the dispute test results do not confirm the mixture parameter is out-of-specification, then the Local Agency will pay for the cost of the dispute resolution testing and no price adjustment is required.

If acceptance tests, as described in section e. of this special provision, show that a Table 1 mixture parameter exceeds the Range 2 tolerance limits, the 10,000 gram sample part retained for possible dispute resolution testing will be sent, within 4 calendar days, to the MDOT Central Laboratory for further testing. The MDOT Central Laboratory's test results will be used to determine the penalty per mixture parameter, if any. If the MDOT Central Laboratory's results do not confirm the mixture parameter is out-of-specification, then no price adjustment is required. If the MDOT Central Laboratory's results show that the mixture is out-of-specification, and the Engineer approves leaving the out-of-specification mixture in place, the contract unit and/or base price for the material will be adjusted, based on all parameters, as shown in Table 3 and Table 4.

In the case that the Contractor disputes the results of the test of the second sample obtained for a particular day of production, the test turn-around time frames given would apply to the second test and there would be no time frame on the first test.

g. Measurement and Payment.- The completed work, as described herein, will be measured and paid for using applicable pay items as described in subsection 501.04 of the Standard Specifications for Construction, or the contract, except as modified in Section g. Price Adjustments.

CITY OF ANN ARBOR
DETAILED SPECIFICATION
FOR
HMA PAVING

WT:VCM

1 of 4

01/17/19

a. Description.- Hot Mix Asphalt (HMA) pavement base, leveling, and top courses shall be constructed in accordance with Section 501 of the 2012 MDOT Standard Specifications for Construction, except as modified herein, and as directed by the Engineer.

b. Construction Methods.-

Equipment- All equipment shall conform to Section 501.03.A of the 2012 MDOT Standard Specifications, except as modified herein.

The Contractor shall have a 10 foot long straight edge, rubber-tired backhoe (Case 580 type, or equivalent), air-compressor with the ability to develop a minimum pressure of 100 pounds per square inch and continuous rated capacity of 150 cubic feet per minute of air flow, and jackhammer available during all paving operations. The Contractor shall be required to perform any miscellaneous cleaning, trimming, material removal, and other tasks as required by the Engineer in order to ensure the proper and orderly placement of all HMA materials on this project.

The Contractor shall provide sufficient rollers to achieve the specified asphalt densities.

At various times throughout the work, the Engineer may direct the Contractor to use smaller and/or lighter equipment, and to defer certain work tasks, in order to protect the grade and/or adjacent areas; including hauling units. The Contractor shall not be entitled to any additional compensation for the use of smaller equipment, lighter equipment, or work task deferral.

Cleaning and Bond Coat application- Cleaning and bond coat application shall be performed in accordance with Sections 501.03.C and 501.03.D of the 2012 MDOT Standard Specifications, except as modified herein, and as directed by the Engineer.

The Contractor shall furnish and operate throughout the construction period, vacuum-type street cleaning and utility structure cleaning equipment (Vac-All, Vactor, etc.) approved by the Engineer, and when directed by the Engineer, for street cleaning immediately prior to, and for street and utility structure cleaning after any and all paving. The cleaning equipment shall be of sufficient power to remove dust, dirt, and debris from the pavement and from utility structures in and adjacent to the construction area. The vac-all or similar equipment and shall be approved by the Engineer prior to beginning the work. The equipment used shall have an effective means for preventing any dust resulting from the operation from escaping into the air.

The bond coat shall be applied at a minimum rate of 0.10 gallons/yd². Before placing the bond coat, the existing pavement surface shall be thoroughly cleaned. The Contractor shall also thoroughly clean all joints, cracks, and edges to a minimum depth of one inch with compressed air, vac-all type equipment, or other approved mechanical or hand methods, to remove all dirt, debris, and all foreign material.

HMA Placement- Placement shall conform to Section 501.03.F of the 2012 MDOT Standard Specifications, except as modified herein, and as directed by the Engineer.

HMA placement shall not commence until a "Permit to Place" (no additional costs are required to obtain this permit) has been issued in writing by the Engineer. The Permit to Place shall be issued after the aggregate base course or the adjacent, underlying layer of pavement section has been approved by the Engineer.

The final structure adjustments must be approved by the Engineer prior to the issuance of the "Permit to Place" for the wearing course.

The top course shall be placed with a ¼" lip at the gutter edge of metal.

All HMA thickness dimensions are compacted-in-place.

Paving Operation Scheduling – The Contractor shall schedule the paving operation to avoid longitudinal cold joints that would be required to be left "open" over night.

In all cases, the Contractor shall pave the primary road's through-traffic lanes ("main line") first, from point-of-beginning to the point-of-ending. All other paving including, but not limited to; acceleration and deceleration lanes, intersection approaches, and center left-turn lanes shall be paved following completion of main line paving, unless authorized by the Engineer prior to the placement of any pavement.

Rate of Paver operation - The rate of the paver's travel shall be maintained such that the paving operation will be continuous, resulting in no transverse cold joints, but shall never exceed the rate of 50 feet per minute.

The Contractor shall furnish and operate enough material, equipment, and hauling units so as to keep the paving machine(s) moving continuously at all times. Failure to do so shall be cause for the suspension of the paving operation until the Contractor can demonstrate to the satisfaction of the Engineer, that sufficient resources have been dedicated to perform the work in accordance with the project specifications.

Longitudinal and Transverse Joints- shall conform to Section 502.03.F of the 2012 MDOT Standard Specifications and as specified herein.

For mainline HMA paving, the width of the mat for each pass of the paver shall be not less than 10.5', nor greater than 15', except as noted in the plans and as directed by

the Engineer. The Engineer will direct the layout of all HMA longitudinal joints during construction.

Feather Joints – shall be constructed so as to vary the thickness of the HMA from zero inches to the required paving thickness at the rate of approximately 1.5” over a distance of 10 feet, or as directed by the Engineer. The Contractor shall rake the larger pieces of aggregate out of feather joints prior to compaction.

Butt Joints - Construction of butt joints, where directed by the Engineer, shall conform to Section 501.03.C.3 and 501.03.C.4 of the 2012 MDOT Standard Specifications, except as modified herein.

When a butt joint is specified or directed to be placed by the Engineer, remove the existing HMA surface to the thickness of the proposed overlay, or full-depth, as directed by the Engineer, for the full width or length of the joint. The HMA material shall be sawcut to the directed depth along the pavement edge or removal line to prevent tearing of the pavement surface. Cut joints that will be exposed in the completed surface must be cut with a saw or a cold-milling machine or other methods approved by the Engineer. Joints that will be covered by HMA must be cut with a saw, a cold-milling machine, or other methods approved by the Engineer.

Rakers- the Contractor shall provide a minimum of two rakers during the placement of all wearing and leveling courses.

Faulty Mixtures – The Contractor and Engineer shall carefully observe the paving operation for signs of faulty mixtures. Points of weakness in the surface shall be removed or corrected by the Contractor, at his/her sole expense, prior to paving subsequent lifts of bituminous material. Such corrective action may include the removal and replacement of thin or contaminated sections of pavement, segregated HMA, and any sections that are weak or unstable. Once the Contractor or his representative is notified by the Engineer that the material being placed is out of allowable tolerances, or that there is a problem with the paving operation, the Contractor shall stop the paving operation at once, and shall not be permitted to continue placing bituminous material until again authorized by the Engineer. Any costs associated with meeting the requirements specified herein shall not be paid for separately, but shall be included in the item(s) of work being performed at the time the faulty mixture was discovered.

c. Application Estimate

STREET NAME	PAY ITEM	HMA MIX	APPLICATION RATE	EST. THICKNESS	PERFORMANCE GRADE	AWI (min)
Greene Street	HMA, 5E1	HMA, 5E1	165 lb/Syd	1.5"	PG 64-28	260
	HMA, 4E1	HMA, 4E1	165 lb/Syd	1.5"	PG 64-28	260
	HMA, 3E1	HMA, 3E1	330 lb/Syd	3.0"	PG 64-28	260
Hill and Hoover Streets	HMA, 5E1	HMA, 5E1	220 lb/Syd	2.0"	PG 64-28	260
	HMA, 4E1	HMA, 4E1	220 lb/Syd	2.0"	PG 64-28	260
	HMA, 3E1	HMA, 3E1	330 lb/Syd	3.0"	PG 64-28	260

The Performance Grade asphalt binder range for the HMA mixture shall be as noted above.

The Bond Coat material shall be applied in accordance with the requirements of the Special Provision entitled "HMA Paving, City of Ann Arbor." The uniform rate of application shall be a minimum of 0.10 gallons/yd² and be approved by the Engineer. This work will not be paid for separately but shall be included in the cost of other pay items.

d. Measurement and Payment.- The completed work as measured shall be paid for at the contract unit price for the following contract items (pay items):

<u>Contract Item (Pay Item)</u>	<u>Pay Unit</u>
Item 266: HMA, 3E1	Ton
Item 267: HMA, 4E1	Ton
Item 268: HMA, 5E1	Ton

Unused HMA remaining in trucks after the work is completed shall be returned to the plant and re-weighed, and the corrected weight slip shall be provided to the Engineer. No payment will be made for the unused HMA material. All weight slips must include the type of mixture (codes are not acceptable), as well as vehicle number, gross weight, tare weight and net weight.

All costs of meeting the requirements of this special provision shall be included in the bid prices for HMA items in the proposal and will not be paid for separately.

CITY OF ANN ARBOR
DETAILED SPECIFICATION
FOR
NO PARKING SIGNS

WT:VCM

1 of 2

01/17/19

a. Description. This work shall consist of installing, maintaining and removing of "No Parking" signs and posts as outlined herein and as referenced on the plans. "No Parking" signs shall be installed in accordance with the section 812 of the Michigan Department of Transportation (MDOT) 2012 Standard Specifications for Construction Standard Specifications and the 2011 Michigan Manual of Uniform Traffic Control Devices (MMUTCD).

b. Materials. The City will furnish "No Parking" signs to the Contractor at no cost. The Contractor shall furnish the sign support and mounting hardware materials, which materials shall be in accordance with those specified in section 919 of the MDOT 2012 Standard Specifications for Construction.

c. Construction. Prior to the commencement of any construction activity, the Contractor shall place "No Parking" signs as directed by the Engineer. The Contractor shall obtain a permit for "Temporary Permission of Reserve Parking Lane for Work Related Purposes" from the City's Project Management Services Unit. This permit shall be obtained a minimum of 5 business days prior to the posting of "No Parking" signs.

The Contractor shall securely bolt the signs to the sign supports as directed by the Engineer. The Contractor shall imbed the sign supports at least two feet into the ground, and there shall be a minimum of six feet and maximum of seven feet of clearance maintained between the bottom of the sign and the ground. The signs are to be placed at intervals no more than 75 feet, and as necessary to eliminate parking in the construction area.

The installation of "No Parking" signs shall be in accordance with the permit. "No Parking" signs shall be installed by the Contractor, as directed by the Engineer, at least 48 hours prior to the proposed start-of-work/enforcement date. "No Parking" signs shall be covered by the Contractor, thereby allowing on-street parking, until between 48 and 24 hours prior to the start of the work. "No Parking" signs shall be covered by the Contractor whenever there is no work being performed for a period of time longer than 72 hours. "No Parking" signs shall be returned to the City upon the completion of work. The cost of unreturned signs will be back charged to the Contractor.

d. Measurement and Payment. The completed work, as described, will be measured and paid for at the contract unit price for the following pay item:

<u>Pay Item</u>	<u>Pay Unit</u>
Item 270: No Parking Sign.....	Each

The item **No Parking Sign** will be measured as the maximum number of signs installed on the project at any one time. The unit price includes the removal and return of "No Parking" signs to the City upon completion of the project. The Contractor shall be back charged for the replacement costs for damaged or unreturned signs.

CITY OF ANN ARBOR
DETAILED SPECIFICATION
FOR
PROTECTING AND PRESERVING IRRIGATION SYSTEMS

WT:VCM

1 of 2

01/17/19

a. Description. This work shall consist of all labor, materials, and equipment necessary to investigate, locate, save and protect from damage, ensure continued and proper operation during the performance of the project work, re-establish operation as necessary, and upon completion of all project work, ensure that all existing sprinkler systems located within the project limits, or those affected by the project, are functioning in a satisfactory manner as determined by the Engineer.

b. Materials. None specified.

c. Construction. The Contractor shall be aware that properties located within the project limits have underground sprinkler systems that irrigate both private property and portions of the public right-of-way. The irrigation systems have been installed by a variety of private installers and may utilize several different materials and/or suppliers of the various components. Portions of the existing irrigation systems have been installed under paved areas, extend into landscaped islands, or may be required to be located within such areas at the conclusion of the project's construction.

The contractor shall perform the necessary investigations to determine the precise location of the irrigation systems, and all affected components, prior to the commencement of construction operations, determine all impacts to the systems that will result pursuant to the project's construction, and take the needed actions to ensure that the sprinkler systems will remain functional during the project's construction, and will be re-established in such a manner at appropriate intermediate and final project milestones, that the original functionality of the system is maintained to the greatest extent possible.

The Contractor shall contact all property owners prior to the commencement of the work in order to determine the impacts to their irrigation systems and coordinate the project's work with them to ensure satisfactory operation of the irrigation systems during construction.

All work shall be approved by the Engineer and the affected property owner(s) at the conclusion of the project's work.

This is an allowance type item. This allowance is not for solving problems caused by the Contractor's own neglect, errors, omissions or other deeds of the Contractor's own fault. Protecting existing irrigation systems where it is not necessary to remove it to complete the work is included in the contract unit price for the pay item **General Conditions, Maximum \$_____**.

The Contractor is required to present a detailed scope of work and detailed costs for any Work contemplated under the irrigation system allowance to the Engineer. No Work

is to begin until scope and costs have been finalized and approval by the Engineer in writing.

Thereafter, if the approved price for this work is more or less than the lump sum allowance amount of the lump sum in the Contract, the Contract Lump Sum Price shall be adjusted accordingly by Change Order. The payment shall be made on the basis of the actual approved amount without additional charge or markups for overhead, insurances, bonds, or any other incidental expenses. The Contractor shall be responsible for all coordination involved and for the timely completion of the Work to fit his schedule.

d. Measurement and Payment. The completed work, as described, will be measured and paid for at the approved price for the following pay item:

<u>Contract Item (Pay Item)</u>	<u>Pay Unit</u>
--	------------------------

Item 272: Irrigation System, Protection and Maintenance	Lump Sum
---	----------

The approved price for this item shall include all labor, material, and equipment costs required to complete the work.

CITY OF ANN ARBOR
DETAILED SPECIFICATION
FOR
PROJECT CLEAN-UP AND RESTORATION, SPECIAL

WT:VCM

1 of 2

01/17/19

a. Description.- This work consists of performing on-going clean-up, removing, and disposing of debris; including soil erosion control fences, protective fences, fallen timber, logs, brush, rocks, boulders, and any other rubbish generated from the Contractor's operations within the project limits or areas impacted by their operations. The Contractor shall perform final restoration and establish the planting areas as described in this Detailed Specification, as indicated on the Drawings, and as directed by the Engineer.

The related work of salvaging the existing topsoil, stockpiling the existing topsoil, preparing the earth bed, re-spreading the topsoil, furnishing the seed mixtures, sowing the seed, furnishing, placing, and anchoring the mulch blanket shall conform to the requirements of this Detailed Specification and Section 816, Turf Establishment, of the 2012 edition of the Michigan Department of Transportation (MDOT) Standard Specifications for Construction.

b. Materials.- The materials shall meet the requirements specified in the 2012 edition of the MDOT Standard Specifications for Construction, except as specified herein:

1. Mulch.- Mulch seeded areas with the appropriate materials for the site conditions to promote germination and growth of seed and to mitigate soil erosion and sedimentation. Mulch blankets shall be as specified in the Detailed Specification for "Turf Establishment".

c. Construction.- Provide project cleanup as an ongoing operation. Perform project cleanup within the right-of-way and any other areas impacted by the project work operations.

Fill all holes and ruts resulting from the work operations with Engineer-approved material. Compact and level all backfill materials and restore ruts and holes to the surrounding contour as directed by the Engineer.

Grade, spread topsoil, remove rocks over 2 inches in diameter, place additional topsoil (as needed), place permanent seeding, and furnish, place, and anchor erosion control straw mulch blanket in all areas disturbed by the Contractor's operations. The Contractor shall be responsible for performing the permanent restoration of the Project area and other areas as part of the work of this Detailed Specification.

Topsoil placement shall occur at the locations called for on the Drawings or as directed by the Engineer. Minimum topsoil thickness in restoration areas shall be 4 inches. The Contractor may be required to truck in additional topsoil.

Damage to seeded areas resulting from erosion shall be repaired by the Contractor at the Contractor's expense. Scattered bare spots in seeded areas will not be allowed over 3 percent of the area nor greater than 6- by 6-inch in size.

Clean existing culverts, ditches, depressions, or other areas that contain sediment or debris from the work operations.

Neatly fill any ruts or depressions resulting from removal of soil erosion control materials with existing materials after their removal. Maintenance of silt fencing and other soil erosion control materials until such time as they are no longer needed, then removal and proper disposal of them from the site, shall be included in the bid price for the related soil erosion control device.

The project site shall be left in a condition that is clean and free of all project-generated debris and to the satisfaction of the Engineer.

d. Measurement and Payment.- The completed work as measured shall be paid at the contract unit price for the following contract pay items:

<u>Contract Pay Item</u>	<u>Pay Unit</u>
Item 274: Project Clean-Up and Restoration, Special - _____	Lump Sum

The lump sum price for "Project Clean-Up and Restoration, Special - _____" shall include all remaining project clean-up and restoration work, including all labor, material, and equipment costs required to complete the work as specified herein.

CITY OF ANN ARBOR
 DETAILED SPECIFICATION
 FOR
TURF ESTABLISHMENT

WT:VCM

1 of 3

01/17/19

a. Description.- This work shall consist of furnishing and placing 4” of Engineer-approved topsoil, seeding lawn areas, and placing mulch blankets as indicated on the plans, as detailed in the specifications, or as directed by the Engineer.

The related work of preparing the earth bed, furnishing, and placing the topsoil, furnishing the seed mixtures, furnishing the fertilizer, sowing the seed, furnishing and installing the mulch blanket and watering shall conform to the requirements of this Special Provision and Section 816, Turf Establishment, of the Michigan Department of Transportation (MDOT) 2012 Standard Specifications for Construction.

b. Materials.- The materials shall meet the requirements specified in Section 917 of the 2012 MDOT Standard Specifications for Construction except as specified herein:

- Seed shall be fresh, clean, dry, new-crop seed complying with the AOSA’s “Rules for Testing Seed”, tested for purity and germination tolerances.

Variety	Proportion By Weight	Purity	Germination
Baron Kentucky Bluegrass	25%	90	80
Kentucky Bluegrass 98/80	15%	98	80
Park Kentucky Bluegrass	15%	90	80
Omega III Perennial Ryegrass	20%	98	90
Creeping Red Fescue	25%	95	90

Maximum weed content shall be 0.30%.

- Fertilizers shall be a Class A. The percentages by weight shall be at a minimum 10N-10P-10K or as required and approved by the Engineer.
- The seed, fertilizer, and adhesive (mulch binder) shall be mixed together and applied at one time.
- Water used shall be obtained from fresh water sources and shall be free from injurious chemicals and other toxic substances.

Mulch Blankets shall meet the requirements of Section 917.15.B.2.b of the 2012 MDOT Standard Specifications for Construction.

c. Maintenance and Acceptance.- It is the responsibility of the Contractor to establish a dense, vigorous, weed free lawn of permanent grasses, free from mounds and depressions prior to final acceptance and payment of this project. Any portion of a seeded area that fails to show a uniform germination, shall be re-seeded. Such re-seeding shall be at the Contractor's expense and shall continue until a dense, vigorous and weed free lawn is established.

The Contractor shall maintain all lawn areas until they have been accepted by the Engineer. Lawn maintenance shall begin immediately after the grass seed is in place, and shall continue until final acceptance with the following requirements:

- Lawns shall be protected and maintained by watering, mowing, and reseeding as necessary, until the period of time when the final acceptance and payment is made. The Contractor shall establish a uniform, dense, vigorous, and weed-free stand of the specified grasses. Maintenance includes, but is not limited to; deposition of additional topsoil; re-seeding; watering; fertilizing; mowing, and any other work as required to correct all settlement, erosion, germination, and establishment issues until the date of final acceptance by the Engineer.
- Damage to seeded areas resulting from erosion shall be repaired by the Contractor at the Contractor's expense. Scattered bare spots in seeded areas will not be allowed over three (3) percent of the area nor greater than 6"x 6" in size.

When the above requirements have been fulfilled, the Engineer will accept the lawn.

d. Measurement and Payment.- The completed work shall be paid for at the contract unit price for the following contract items (pay items):

<u>Contract Item (Pay Item)</u>	<u>Pay Unit</u>
Item 276: Topsoil Surface, __ inch	Square Yard
Item 277: Seeding and Mulching	Square Yard

"Topsoil Surface, __ inch" and "Seeding and Mulching" will be measured by area in square yards and will be paid for at the contract unit prices which shall be payment in full for all labor, materials, and equipment needed to accomplish this work.

Topsoil placement shall occur at the locations called for on the plans or, as directed by the Engineer. The unit price "Topsoil Surface, __ inch" shall include the grading of the area to receive the topsoil, preparing the earth bed, spreading and raking the topsoil to provide a uniform surface free of large clods, lumps, rocks, brush, roots, or other deleterious materials, as determined by the Engineer.

The seeding shall be placed on all lawn areas as called for on the plans, and shall include furnishing and installing seed, fertilizer, mulch blankets, and all required watering necessary for the establishment of the turf. Watering will not be paid for separately.

After initial placement of the topsoil and seed mixture(s), fifty (50) percent of the total quantity placed for each item will be certified for payment. The remaining fifty (50) percent of the total quantities will be held by the Engineer until such time as all lawn areas have been established and accepted by the Engineer.

Final acceptance shall occur no sooner than June 15th of the year after the year in which the lawn areas were initially planted during the previous spring planting season; or, final acceptance will occur no sooner than November 1st of the year after the year in which the lawn areas were initially planted during the previous summer planting season.

In no case shall lawn areas be accepted in the same year in which they were planted.

CITY OF ANN ARBOR
DETAILED SPECIFICATION
FOR
STORM CONTROL STRUCTURE

WT:VCM/CEW

1 of 1

01/28/19

a. Description. This work shall include complete installation of control structure(s), as shown on the Plans, and as directed by the Engineer, including; excavation and proper removal of all excavated materials, including existing structures to be removed; concrete base; pipe connections; insertion over existing sewers; precast structure sections or concrete block; precast weir wall; backfilling and compaction; flow channels; steps; concrete bricks; mortar; frame; cover; adjustment to finish grade; and structure cleaning.

b. Construction. Construction of the manhole structure shall comply with all requirements and standards of the City of Ann Arbor Standard Specifications for Type II manholes. Contractor shall submit details for approval of manhole with center wall showing method of anchoring center wall to base slab and manhole walls.

The 24" conical flow control valve shall be self-activated by utilizing the upstream hydraulic head. The unit shall consist of a slotted intake, a cone and an outlet and shall be installed into the precast weir wall as shown on the Plans. Flow is directed tangentially into the cone that reduces the design peak discharge flow rate from the conical valve far below an equivalent diameter simple orifice.

The conical flow control valve shall be capable of limiting the discharge flow to less than 2.5 cfs throughout the range of upstream head conditions of 0-4'.

The unit shall be constructed of 304 stainless steel and shall include a pivoting bypass door to allow maintenance should plugging occur. The unit shall be installed in the precast structure weir wall using an appropriately sized sleeve and o-ring gaskets.

b. Measurement and Payment. Control Structure as specified will be paid for at the Contract unit price each. Payment includes furnishing the labor, equipment and materials for all necessary excavation, disposing of surplus excavated material, backfilling, and constructing the structure complete, including pipe connections and structure cleaning.

PAY ITEM

PAY UNIT

Item 278: Storm Control Structure, _____ Each

CITY OF ANN ARBOR
DETAILED SPECIFICATION
FOR
PEDESTRIAN LIGHT REMOVE AND RE-INSTALL

WT:VCM

1 of 1

01/28/19

a. Description. This work includes the removal of the existing light pole, base, foundation, wire, luminaire, fixtures, conduit, etc.; and re-installation after completion of the water main connection. This work includes all coordination with University of Michigan (U-M) and City of Ann Arbor (City) to complete work.

This work shall be completed in accordance with the current U-M standards and specifications and National Electric Code (NEC), except as specified herein. Provide conduit, boxes, splices, etc. in accordance with City and U-M standards and specifications.

b. Materials. All materials shall be new and meet the requirements of the current U-M, City, IEEE, NEMA, ANSI Standards as applicable, and as specified herein.

The Contractor shall submit product data sheets for all conduit, handholes, concrete, galvanized steel anchor bolts, covers, wire, and all associated materials. Contractor to provide Granular Material, CI II in accordance with section 902 of the MDOT 2012 Standard Specifications for Construction.

c. Construction. Existing pole, luminaire, and miscellaneous materials shall be removed and properly stored for re-installation. Materials not salvaged or damaged during removal or storage shall be replaced with new material at Contractor's expense. Coordinate removal and installation with U-M and City of Ann Arbor.

All splices of electrical wiring shall be in U-M approved boxes with U-M approved wire splicing devices.

Pole bases and foundations shall be constructed in accordance with U-M standard details.

d. Measurement and Payment. The completed work, as described, will be measured and paid for at the contract unit prices for the following pay items:

<u>Pay Item</u>	<u>Pay Unit</u>
Item 281: Pedestrian Light, Remove and Re-Install	Each

“Pedestrian Light, Remove and Re-Install” shall be paid for at the contract unit prices and shall include all labor, equipment, and materials to complete the work as specified herein. The pay item shall also include the excavation and disposal of materials, furnishing, installing and compacting Granular Material, CI II, all work related to connecting the existing lighting fixture to existing facilities, and coordination with U-M and City.

CITY OF ANN ARBOR
DETAILED SPECIFICATION
FOR
ELECTRICAL AND COMMUNICATION CONDUITS AND HANDHOLES

WT:VCM

1 of 3

01/24/19

a. Description. This work shall consist of furnishing and installing electrical conduit, both directional bored or direct burial, and handhole assemblies at the locations shown in the Plans, or as directed by the Engineer. All work shall be completed in accordance with the current National Electric Code (NEC), section 819 of the Michigan Department of Transportation (MDOT) 2012 Standard Specifications for Construction, except as specified herein.

The Contractor shall excavate all trenches and pits to the required dimensions; sheet, brace, and properly support the adjoining ground or structures where necessary to comply with MIOSHA, Section 104.07.B of the MDOT 2012 Standard Specifications for Construction, and other relevant safety standards.

The work for all items shall include, but not be limited to; pavement saw-cutting; excavation and disposal of excavated material; the furnishing, installation, and removal of sheeting and/or shoring where needed; all items necessary for the protection of the trench and all persons employed in the work during the work day and "after-hours" periods; the furnishing, placement and compaction of approved bedding and backfill materials; additional labor and equipment costs associated with any required nighttime water main work; and any other required items to complete the work as shown on the plans, as detailed in this Detailed Specification, and as directed by the Engineer.

b. Materials. All materials shall be new and meet the requirements of the current IEEE, NEMA, ANSI Standards as applicable, and as specified herein.

The Contractor shall submit product data sheets for all conduit, handholes, covers and other parts for Engineer approval prior to ordering materials. The manufacturer "Quazite Composolite," referenced below, is located in Lenoir City, Tennessee.

12 inch x 18 inch handhole assemblies shall consist of "Quazite Composolite" box. The box shall be #PG1118BA12. The cover shall be, #PG1118HA41, a locking heavy-duty bolt-down type with a logo that reads "Street Lighting." The total depth of the handhole shall be 12 inches.

17 inch x 30 inch handhole assemblies shall consist of two, stacked "Quazite Composolite" boxes. The lower box shall be #PG1730BB18. The upper box shall be #PG1730BA18. The cover shall be, #PG1730HA46, a locking heavy-duty bolt-down type with a logo that reads "Traffic Signal." The total depth of the handhole shall be 36 inches.

24 inch x 36 inch handhole assemblies shall consist of "Quazite Composolite" box. The box shall be #PG2436BA24. The cover shall be, # PG2436HA12, a locking heavy-duty bolt-down type with a logo that reads "Street Lighting." The total depth of the handhole shall be

CITY OF ANN ARBOR
DETAILED SPECIFICATION
FOR
ELECTRICAL AND COMMUNICATION CONDUITS AND HANDHOLES

WT:VCM

2 of 3

01/24/19

24 inches.

Provide Granular Material, CI II in accordance with section 902 of the MDOT 2012 Standard Specifications for Construction.

Provide Schedule 80 HDPE conduit for directional boring in accordance with sections 918 and 819 of MDOT 2012 Standard Specifications for Construction.

c. Construction. Handholes shall be placed at all junctions of traffic signal or electrical conduit, and as shown on the plans. Maximum distance between any two handholes shall be as shown on the Plans, but in no case shall exceed 500 feet.

Place foundation material consisting of four (4) inches of Granular Material, CI II compacted to 95% of its maximum unit weight.

Set the handhole or stacked units to the proper depth and elevation.

Connect handholes to new and existing conduits, whether shown on the plans or not. All conduits shall be connected to the handholes in accordance with the latest revision of Article 346 of the National Electrical Code (NEC).

Backfill around the perimeter of the handhole with Granular Material, CI II compacted to 95% of its maximum unit weight.

Install directional bored conduit in accordance with section 819.03 of the MDOT 2012 Standard Specifications for Construction.

d. Measurement and Payment. The completed work, as described, will be measured and paid for at the contract unit prices for the following pay items:

<u>Pay Item</u>	<u>Pay Unit</u>
Item 282: Handhole Assembly, ___ inch x ___ inch.....	Each
Item 283: Conduit, Directional Bore, ___ inch	Lineal Foot

Handhole Assembly, ___ inch x ___ inch shall be paid for at their contract unit prices and shall include all labor, equipment, and materials to complete the work as specified herein. The pay item shall also include the excavation and disposal of materials, furnishing, installing and compacting Granular Material, CI II, and all work related to connecting handholes to new and existing conduits, whether shown or not shown on the plans.

CITY OF ANN ARBOR
DETAILED SPECIFICATION
FOR
ELECTRICAL AND COMMUNICATION CONDUITS AND HANDHOLES

WT:VCM

3 of 3

01/24/19

Conduit Directional Bore, ___ inch includes all labor, material and equipment necessary to install the conduit, both directional bore and direct bury; construction of bore pits, disposal of excess excavated material, and furnishing, installing of approved bedding and compacting Granular Material, CI II backfill.

CITY OF ANN ARBOR
DETAILED SPECIFICATION
FOR
WATER MAIN AND APPURTENANCES

WT:VCM

1 of 24

01/28/19

a. Description.- The Contractor shall furnish all labor, equipment, pipe, valves, fittings, restrained-joint pipe, restrained-joint gaskets, special gaskets as detailed on the plans and in the specification, polywrap, blow-off assemblies, fire hydrants, fire hydrant extensions, supplemental lighting towers, and all other materials necessary to complete the work as shown on the Plans, as detailed in this Detailed Specification, and as directed by the Engineer.

All water main installation and testing procedures shall be performed in accordance with the plans, the requirements of this Detailed Specification, and as directed by the Engineer. The Contractor shall excavate all trenches and pits to the required dimensions; sheet, brace, and properly support the adjoining ground or structures where necessary to comply with MIOSHA, Section 104.07.B of the MDOT 2012 Standard Specifications for Construction, and other relevant safety standards.

The work for all items shall include, but not be limited to; pavement saw-cutting; excavation and disposal of excavated material; connections to new and existing water mains; the furnishing and installation of solid sleeves and push-on-joint plugs where needed; the furnishing, installation, and removal of sheeting and/or shoring where needed; all items necessary for the protection of the trench and all persons employed in the work during the work day and "after-hours" periods; polywrap; the furnishing, placement and compaction of approved bedding and backfill materials; thrust blocks; additional labor and equipment costs associated with any required nighttime water main work; cleaning, disinfecting, flushing, bacteriological and hydrostatic testing; and any other required items to complete the work as shown on the plans, as detailed in this Detailed Specification, and as directed by the Engineer.

The work of installing a gate valve-in-well shall include installation and backfill of the specified valve, furnishing and installing pre-cast concrete gate wells including the concrete base, straight pre-cast concrete sections, transition sections, and the adjustment of the structure cover. No separate payment will be made for adjusting the structure covers on new gate wells. The gate well cover shall be paid as "Dr Structure Cover." Upon completion of the work, the Contractor shall clean the Gate Well to the approval of the Engineer.

The cost of adjusting new gate valve-in-boxes shall be included in the unit price for Gate Valve-in-Box and shall not be paid for separately.

The fire hydrant assembly work shall include the hydrant, the 6 inch gate valve-in-box, 3 feet of 6 inch pipe, the thrust block, and any required extensions to install the fire hydrant to the finish grade as shown on the plans.

b. Materials.-

1. Submittals. Prior to beginning construction, the Contractor shall submit the following:
 - A. Product data on all ductile iron pipe, valves, fittings, asbestos concrete pipe to ductile iron pipe fittings, and hydrants.
 - B. Manufacturer's certifications on all pipe, fittings, and precast concrete units indicating that all materials meet the minimum requirements of these specifications.
 - C. Information on equipment and methods to be used for flushing, chlorination, pressure and bacteriological testing.
2. General Specifications.
 - A. Cast Ductile Iron Pipe and Fittings:

Cast ductile iron pipe shall be Iron Grade 60-42-10 and meet the requirements of ANSI/AWWA C151/A21.51 in all respects; with standard thickness cement mortar lining and asphaltic seal coat in accordance with ANSI/AWWA C104/A21.4; and, coated outside with an asphaltic coating in accordance with ANSI/AWWA C151/A21.51. 100% of the ferrous metals used in the manufacture of cast ductile iron pipe shall be recycled from scrap and other sources.

All pipe (except for pipe in bored steel casing) shall be either Pressure Class 350 (Table 50.5 ANSI/AWWA C150/A21.50) as detailed on the plans, or Thickness Class 50 (Table 50.15, ANSI/AWWA C150/A21.50). Pipe in bored steel casing under railroad shall be Thickness Class 56.

Cast ductile iron river crossing pipe shall be Clow Corp. "F-141 River Crossing Pipe", U.S. Pipe "USIFLEX Boltless Flexible Joint Pipe" or equal approved by the Engineer, and shall be thickness Class 56 minimum. The pipe shall have a boltless flexible joint of the ball and socket type, and be designed for, and rated at, a minimum interior working water pressure of 250 psi.

Restrained joint pipe, where called for on the Plans, shall be boltless, factory-manufactured, by the installation of retainer weldment and ductile iron locking segments or rings. Restrained joint pipe shall be Ductile Iron manufactured in accordance with the requirements of ANSI/ AWWA C151/A21.51. Joints for restrained joint pipe shall be in accordance with ANSI/AWWA C111/A21.11. Restrained joint fittings and the restraining

components shall be Ductile Iron in accordance with applicable requirements of ANSI/AWWA C110/A21.10 and/or C153/A21.53 with the exception of the manufacturer's proprietary design dimensions. Push-on joints for such fittings shall be in accordance with ANSI/AWWA C111/A21.11.

Restrained joint pipe shall be TR-Flex restrained joint pipe manufactured by U.S. Pipe; Lok-Ring pipe for pipe diameters 54" through 64" or Flex-ring pipe for pipe diameters less than 54" manufactured by American Ductile Iron Pipe; or, equal as approved by the Engineer. Bolts and nuts for "field-cut" retainer assemblies shall be stainless steel.

Cast ductile iron fittings shall be push-on joint (with the exception of solid sleeves and fire hydrants which shall be mechanical joint), meeting the requirements of ANSI/AWWA C110/A21.10 for short body cast iron fittings. Fittings shall have a cement mortar lining and asphaltic seal coat in accordance with ANSI/AWWA C104/A21.4 and ANSI/AWWA C110/A21.10. The outside of all fittings shall have an asphaltic coating in accordance with ANSI/AWWA C110/A21.10.

Solid sleeves shall be long-pattern sleeves.

B. Gate Valves and Gate Valve Boxes:

All gate valves shall be resilient seated meeting the requirements of AWWA C509. All valves shall be of the push-on joint type, unless used on tapping sleeve assemblies, or noted otherwise on the plans. The valves supplied shall be:

- a. Metroseal 250 Resilient Seated Gate Valve as manufactured by U.S. Pipe & Foundry Company
- b. U. S. Pipe and Foundry Tyton Joint, Resilient Wedge Seated Gate Valve, meeting the requirements of AWWA C 509, AWWA C550, and ASTM D 2794
- c. American Flow Control, Series 2500, Single Resilient Wedge
- d. East Jordan Iron Works FlowMaster Resilient Wedge Valve
- e. Mueller Series, 4" through 12", A-2360-38, Resilient Wedge – SL x SL
- f. Tyler Series DRS 250-22 Double Resilient Wedge

All valves shall come equipped with a two-inch square operating nut, opening right.

Valve Boxes shall be Tyler 6860 Buffalo type, Size D, screw-type, 3 piece, 5-1/4 inch shaft and a No. 6 Base for a valve 8 inches or less and a No. 8 base for 10 and 12 inch valves.

C. Gate Valve Wells:

Pre-cast reinforced concrete bases, bottom sections, manhole risers, grade adjustment rings, concentric cones, eccentric cones, and flat-slab tops shall conform to the requirements of ASTM C-478. Joints on precast gate wells shall meet the requirements of ASTM C-443, rubber O-ring gasket.

Flat-slab top, pre-cast, gate wells shall be designed to accommodate HL-93 Modified Live Load requirements as determined by a Professional Engineer licensed by the State of Michigan, regardless of where they are to be installed. For the purposes of design, a HL-93 Modified Live Load shall consist of 1.2 times the design truck or 1.2 times a single 60 kip load, whichever produces the greater stresses.

D. Fire Hydrants:

Fire hydrants shall be East Jordan Iron Works Model 5-BR Water Master BR 250 with traffic flange; American Flow Control 5- $\frac{1}{4}$ " Pacer, WB 67-250; or, Waterous Model TCV-5 with traffic flange. All fire hydrants shall have the following features: a 6 inch mechanical joint pipe connection, ANSI/AWWA C111/A21.11; two 2-1/2 inch National Standard hose connections; one 4 inch Stortz pumper connection; 1-3/8 inch pentagon operating and cap nuts (1-3/8 in. point-to-flat at top; 1-7/16 in. point-to-flat at base); open left; breakable flange construction; no barrel drain; and a painted red finish. Depth of bury (bottom of pipe to ground surface) is generally 6 feet but may vary depending on specific site conditions. The Stortz pumper connection must be 21 in. \pm 3 in. above finished grade, and the breakable traffic flange must be between finished grade and 8 in. above finished grade.

Fire hydrant extensions shall be fully compatible with the manufacturer of the fire hydrant assembly provided and be approved by the Engineer. East Jordan Iron Works hydrants shall be provided with a model 5-BR extension kit; and, Waterous Fire Hydrants shall be provided with a F1-K562-6 extension kit.

All fire hydrants must be certified by Underwriters Laboratory (UL) or the National Sanitation Foundation (NSF) for use in a potable water system.

E. Tapping Sleeves and Valves:

Tapping sleeves and valves shall be manufactured of cast iron or stainless steel and designed for water service with a minimum working pressure of 150 psi. The sleeve shall be a full-bodied split sleeve design manufactured by one of the following manufacturers:

- a) Clow No. F-5205;
- b) Mueller Co. No. H-615;
- c) Waterous Series 800;
- d) East Jordan Iron Works MJ Tapping Sleeve with East Jordan FlowMaster RW Valve;
- e) Tyler/Union D.I. MJ Tapping Sleeve;
- f) Ford Meter Box Company Style FTSS;
- g) Power Seal Model No. 3490 AS;
- h) Smith Blair Model No. 622;
- i) JCM 432 All Stainless Steel Tapping Sleeve; and
- j) Price Brothers Company Tapping Sleeve for Prestressed Concrete Steel Cylinder Pipe (only to be used on concrete water mains.)

Tapping Sleeves for Pre-stressed Concrete Steel Cylinder Pipe shall be in accordance with AWWA M-9. The sleeves shall have a separate gland which permits installation of the sleeve prior to cutting of the prestress wires. The gland shall have a fusion epoxy coated (per AWWA C-213) waterway, and a broad gasket set in a retaining groove of a pressure plate gusseted to eliminate flexing. The gland shall be equipped with load bearing set screws to protect the cylinder. Grout under saddle is needed whether saddle is epoxy coated or not. Sleeves shall be furnished with grouting seals and grout horns to facilitate filling the space between the sleeve and the pipe. Tapping sleeves shall be a Price Brothers Company Tapping Sleeve for Prestressed Concrete Steel Cylinder Pipe or approved equal.

Tapping valves shall be double-disk type of the same manufacture as the sleeve, NRS with two-inch square operating nut-opening right, with a mechanical joint outlet.

All tapping sleeves and valves must be certified by Underwriters Laboratory (UL) or the National Sanitation Foundation (NSF) for use in a potable water system.

F. Asbestos Concrete Pipe to Ductile Iron Pipe Coupling:

The asbestos concrete pipe to ductile iron pipe coupling shall be the "Smith-Blair 415 (23.15"—21.60") Gaskets, Alloy bolts and Epoxy" coupling or equivalent.

G. Joints:

Push-on joints shall be single gasket joint meeting the requirements of ANSI/AWWA C111/A21.11.

Mechanical joints for fire hydrants and solid sleeves shall be in accordance with ANSI/AWWA C111/A21.11 and shall be the Mega Lug Series 1100 joint restraint system manufactured by EBAA Iron Sales, Inc. or the Ford Meter Box Co. Uni-flange Retainer (UFR 1400-D-x style.)

Bolts for mechanical joints shall be high strength, low alloy steel bolts, only, meeting the requirements of ANSI/AWWA C111/A21.11. All bolts, nuts, and washers if required, shall be coated with a factory-applied fluoropolymer coating meeting the following requirements:

Use Temperature: -100°F to 500°F

Salt Spray – ASTM B117 up to 4000 hours (nuts must not become frozen)

Pencil Hardness – 5H to 6H – ASTM D3363-92A

Kinetic Coefficient of Friction – 0.06 to 0.08

Thickness – nominal 0.001" (1 mil)

Impact – 160 in-lbs as measured by ASTM D2794-93

Adhesion – 5B – ASTM D3359-95

Di-electric Strength – 500V per mil

Elongation – 35% to 50%

Tensile Strength – 4,000 psi

Operating Pressure – up to 100,000 psi

Kesternich Test – Nuts not frozen up to 30+ cycles (DIN 50018)

Corrosion Resistance: as measured by;

ASTM D 1308 Muriatic Acid 31% HCL - 24 hours - No Effect

Sulfuric Acid 93% H₂SO₄ - 24 hours - No Effect

Caustic Soda 100% NaOH - 24 hours - No Effect

Methy Ethyl Keytone MEK - 24 hours - No Effect

ASTM B117 Salt Fog - 1,000 hours - No Effect

The fluoropolymer coating shall strongly adhere to surface being coated and shall not flake off or be easily removed by rubbing or brushing.

Cast ductile iron river crossing pipe joints shall be a push-on type ball and socket joint utilizing a first grade rubber gasket. The joint shall be capable of 15-degree full turning deflection without separation, leakage, or restriction of the pipe waterway. Joint restraint shall be provided by a boltless means which is locked against accidental disengagement of the restraining component. Pipe shall be furnished with the necessary gaskets, lubricant, and retainer locking accessories.

Restrained, push-on joint, pipe shall be American Pipe's "Fast-Grip" gasket system; U.S. Pipe's "Field-Lok 350" gasket system; or, Griffin Pipe "Field-Lok 350" gasket system.

The use of retainer glands and set screws shall not be acceptable.

Lubricants used in making up joints shall be supplied by the pipe manufacturer and the joints shall be coupled in accordance with the manufacturer's requirements.

H. Pipe Wrapping:

All Cast Ductile Iron Pipe, Fittings, and Valves (except river crossing pipe) shall be fully wrapped with polyethylene per ANSI/AWWA C105/A21.5 and the details as contained on the plans.

I. Casing Pipe:

Steel casing pipe used for construction at railroad or State highway crossings shall comply with the following minimum requirements unless more stringent requirements are established by the railroad or State. Casing pipes at other locations shall comply with the following minimum requirements unless otherwise indicated on the Plans or in the Specifications.

<u>Nominal Diameter of Casing Pipe (Inches)</u>	<u>Minimum Wall Thickness (Inches)</u>
Under 14	0.250
14, 16, and 18	0.312
20 and 22	0.375
24, 26, 28, and 30	0.500
32 and 34	0.563
36, 38, 40, 42, and 48	0.625

Steel pipe shall be non-spiral pipe and have a minimum yield strength of 35,000 psi. All joints shall be made leakproof using full penetration, continuous welds. Welds shall be ground smooth outside and inside (except inside 22 in. diameter and less) to prevent conflict with the soil or pipe placement. Steel pipe shall meet the requirements of ASTM A 53, Type E or S, Grade B.

Pipe Marking:

The following information shall be clearly marked on each length of pipe:

- a) The pipe designation and class (e.g. A 53, Type S, Grade B.)
- b) The name or trademark of the manufacturer.
- c) Identification of the manufacturing plant.

Inspection:

All casing pipe furnished shall be subject to inspection on arrival at the job site by the Engineer. The purpose of the inspection shall be to cull and reject pipe that, independent of physical tests specified under the standard specifications designated herein, fails to conform to the requirements of these Specifications.

Rejected pipe shall be plainly marked by the Inspector and immediately removed from the site of the work by the Contractor, without cost to the City.

J. Water Main Pipe Marking:

The following information shall be clearly marked and/or cast on each length of pipe:

- a) The pipe designation and class (e.g., D.I., Class 50).
- b) The name or trademark of the manufacturer.
- c) Country where cast.
- d) The year in which the pipe was produced.

The following shall be distinctly cast on each fitting:

- a) The pressure rating of the fitting.
- b) Nominal diameters of openings.
- c) The name or trademark of the manufacturer.
- d) Country where cast.
- e) The number of degrees or fraction of the circle on all bends.
- f) Ductile iron fittings shall have the letters "DI" or "Ductile" cast on them.

K. Manufacturer's Certification:

All pipe furnished shall be accompanied by the manufacturer's certificate of test showing conformity with the Specifications. Each certificate shall identify a specific lot number, quantity of pipe, and show actual test results for the lot furnished. These certificates shall be submitted to the Inspector at the time of unloading.

All materials that will potentially be in contact with the City of Ann Arbor water supply must be certified by Underwriters Laboratory (UL) or the National Sanitation Foundation (NSF) for use in a potable water system. These materials shall include pipe coatings, pipe metals, cement linings, and joint lubricants and gaskets.

L. Inspection:

All pipe furnished shall be subject to inspection on arrival at the job site by the Engineer. The purpose of the inspection shall be to cull and reject pipe or fittings that, independent of physical tests specified under the standard specifications designated herein, fail to conform to the requirements of these Specifications.

The Contractor shall notify the Engineer sufficiently in advance so that an Inspector may be on the job during the unloading of materials. A minimum notice of 24 hours is required for such unloading and inspection. The Contractor shall also notify the Engineer when the material has arrived at the site.

All ductile iron water main pipe shall be stacked on pallets off of the existing grade, with each end plugged or bagged so as to keep the pipe interior clean until final installation.

Cast ductile iron pipe and fittings shall be subject to rejection on account of any of the following:

- a) Variation in any dimension exceeding the permissible variations given in the material specifications.
- b) Any crack or defect in the cement mortar lining which, in the opinion of the Engineer, is non-repairable, including, but not limited to, loose or "hollow" lining.
- c) Any signs of physical damage or poor manufacturing which might render the material unsuitable for its intended use.
- d) Variation of more than 1/16 inch per lineal foot in alignment of pipe intended to be straight.
- e) Damaged ends, where in the judgment of the Engineer such damage would prevent making a satisfactory joint.
- f) Improper handling during delivery, unloading, or installation.

Rejected pipe shall be plainly marked by the Inspector and immediately removed from the site of the work by the Contractor, without cost to the City.

M. Water Main Bedding and Backfill Materials:

Bedding and backfill material for Trench Detail I (under roadbed), Modified, shall be Granular Material, Class II, meeting the requirements of Section 902. Bedding and backfill for Trench Detail V (outside of the 1:1 influence line of roadbed or curb and gutter), Modified, shall be Granular Material, Class II and Engineer approved native material, placed in accordance with the trench details.

c. Water Main Installation, Bacteriologic and Hydrostatic Testing, and Acceptance Requirements.- Installation of proposed water mains will require work in close proximity to existing utilities. This must be taken into consideration when the contractor determines the required trench safety requirements. All excavation shall conform to all relevant MIOSHA Standards; the Contractor is solely responsible for determining all excavation and trench safety requirements.

A. Dry Tap:

When a connection to an existing water main is to be made in the dry, the existing main to which a connection is to be made shall be isolated by the closing of the necessary existing valves, and the water from the existing main shall then be pumped out or removed by other means so that the connection may be made in the dry. All pipe materials and appurtenances which will come into contact with potable City water after the restoration of water service following the connections shall be disinfected with a strong chlorine solution prior to installation.

The Contractor may not operate City water main valves. For valve operation, contact City of Ann Arbor Public Services Area personnel; the City of Ann Arbor personnel will direct the operation of all valves by Contractor personnel. It is recommended that the Contractor request that the existing valves, which will need to be operated in order to perform the water main work, are checked in advance of the work to ensure that they operate properly. If the Contractor elects not to request the operation of the valves in advance of any required water main operation, then a request for extension of contract time will not be allowed.

It is possible that the valves which need to be operated to facilitate a shutdown will not close entirely, thereby allowing water to leak past the valve into the area of the shut down. The Contractor shall provide the necessary labor, material, and equipment to enable work to be completed with a poor shut down. Under no circumstances shall the Contractor be compensated for "downtime" associated with water main valve or appurtenance failure or its inability to properly operate or close fully. An extension of contract time may be allowed, if the Contractor has requested that the water main valves have been exercised in advance of the intended water main shutdown.

Due to the size and length of pipe being shut down, and the quality of shut-down attained, large amounts of water may need to be removed from the excavation. Where possible, the water shall be run directly into nearby storm sewer inlets via pumps and hose.

The Contractor shall have all pipe, fittings and appurtenances required to complete the water main connection prior to the excavation for the connection, or the work will not be allowed to commence.

The Contractor shall complete the water main work in a manner which minimizes

the disruption of water service to the greatest extent possible.

The City must notify all businesses 48 hours in advance of a water main shut-down; residences must be notified 24 hours in advance. To give the City an opportunity to provide such notification, the Contractor shall schedule the water main shut-downs at least 72 hours in advance, and preferably a full four or five days in advance, of the water main shut-down.

No water main shutdown shall take place after 12:00 p.m. (noon), unless written permission has been granted by the Engineer and that the Contractor has sufficient lighting equipment to provide a safe and efficient work area for working after dark. No water main will be shut down until the main has been exposed and cleaned, and is ready to be cut.

There shall be no gap larger than 1/4 inch left in the existing water main as a result of the tie-in. If needed, a closure piece ("thrust ring") of such size so as to meet this requirement shall be installed.

B. Wet Tap:

Prior to the installation of a tapping sleeve, the section of pipe to be tapped shall be cleaned of all foreign material and wire brushed to a smooth surface. The two halves of the sleeve shall be placed around the pipe with the gaskets installed per the manufacturer's instructions. The bolts shall be tightened evenly from the center toward the ends. The bolts shall be tightened to the manufacturer's specified torque.

When performing a wet tap in a prestressed concrete steel cylinder water main, grout is to be placed under the tapping saddle whether or not the saddle is epoxy coated.

All pipe materials and appurtenances which may come into contact with potable City water shall be disinfected with a strong chlorine solution prior to installation. This includes the pipe section to be tapped, the two halves of the sleeve, gaskets and the gate valve.

Prior to installation of the end gaskets, the sleeve shall be blocked with cement bricks such that the outlet is in proper position. The end gaskets shall be installed with an overlap as specified by the manufacturer.

The glands shall be assembled on the pipe. The bolts around the gland shall be tightened evenly, causing the gaskets to uniformly compress.

The valve shall be installed on the sleeve following the manufacturer's instructions.

Prior to tapping, the assembly shall be tested using the test plug tap in the sleeve with the valve closed, or by placing a tapped plug on the outlet of the valve with the valve open. The assembly shall be pressurized to 150 psi and hold the pressure fifteen minutes. After the pressure test is complete, the pipe shall be tapped.

C. Oversized Water Mains:

Portions of the proposed water mains or fittings may connect with existing water mains or fittings. The possibility exists that some of the existing water mains may have been constructed using oversized, cast iron, pipe. Where tie-ins or interconnections are specified and the existing main is found to be oversized, the Contractor shall furnish and install Clow 3501B Sleeves, Tyler Dual Sleeve 5-146L, or Rockwell 441 Sleeves. These sleeves are to be present on the jobsite prior to the excavation for the water main connection, or the work will not be allowed to commence.

D. Permissible Deflection at Joints:

Wherever it is necessary to deflect ductile iron pipe from a straight line, either in the vertical or horizontal plane, to avoid obstructions, to plumb valve stems, or where long-radius curves are permitted, the amount of deflection allowed shall not exceed that required for satisfactory making of the joint, and shall be approved by the Engineer. The deflection shall not exceed the following amounts:

Size of Pipe (Inches)	Joint Angle (Degrees)	Deflection in 18 ft. (Inches)	Approx. Radius of Curve Produced by Succession of 18 ft. Lengths (Feet)
4	5	19	205
6	5	19	205
8	5	19	205
10	5	19	205
12	5	19	205
16	3	11	340
20	3	11	340
24	3	11	340
30	3	11	340

The above joint deflection angles apply to fittings as well as pipe joints.

E. Trench Opening:

The Contractor shall fully comply with all laws and regulations governing construction methods and the furnishing and use of all safeguards, safety devices, protective equipment, and pollution controls. Where required to support the surfaces of adjacent roadways, structures, or excavations, or to protect the construction work, adjacent work, or workmen, the Contractor shall design and

install sheeting, bracing, and shoring. The Engineer will not review the Contractor's design(s) or be responsible for the adequacy of the elements supporting the trench. The placing of such supports shall not release the Contractor of the responsibility for the sufficiency and integrity of the trench, trench opening, and the safety of all persons involved in the work.

Sheeting, bracing, and shoring shall not be left in place after completion of the work except as required by the Engineer. In the removing of sheeting and bracing after the construction has been completed, special care shall be taken to prevent any caving of the sides of the excavation and injury to the completed work or to adjacent property. Where the Engineer requires the sheeting, bracing, or shoring to be left in place it shall be cut off below the established surface grade as required by the Engineer.

All excavation shall be performed in such a manner as to provide adequate room for the construction and installation of the work to the lines, grades and dimensions shown on the Plans. The width of the trench shall be ample to permit the pipe to be laid and jointed properly, and the backfill to be placed and compacted as specified. For each size of pipe, the minimum trench width shall provide clearance of four inches on each side of the bell of the pipe or fitting or six inches on each side of the pipe barrel, whichever is greater. Trenches shall be of such extra width, when required, to permit the convenient placing of timber supports, sheeting and bracing, and handling of special fittings. The Work shall be performed such that the existing utilities, asphalt curb and gutter, and existing pavement shall be protected at all times.

In excavating for water mains, the excavation shall at all times be finished to the required grade in advance of the pipe line, but unless otherwise permitted in writing by the Engineer, not more than 50 feet of trench shall be open at one time in advance of the pipe. At no time shall more than 200 feet of trench be opened and incompletely backfilled. At the end of each day, no more than 10 feet of trench may be left open, and access to all drives shall be restored. This opening shall be surrounded by fencing and barricades, or plated. The remainder of the trenching operation shall be available for safe vehicular and pedestrian traffic at all times.

It is essential that the discharge of the trench de-watering pumps be conducted to natural drainage channels, drains, or storm sewers. Engineer-approved soil erosion and sedimentation controls shall be installed and maintained at the point of discharge.

The length of street which may be occupied by the construction work at any one time shall be subject to the approval of the Engineer and will be based on the requirements of use of the street by the public.

F. Boring Pits

The means and methods of boring pit excavation and support, in whatever conditions encountered or created, shall be determined by the Contractor, subject to approval by the Engineer. All costs shall be included in the Contract Price per lineal foot of bored water main. Perform all excavations required for construction of pits, shafts, and other structures. Excavations shall include any and all materials encountered in the Work, such as topsoil, clay, sand, gravel, cinders, rocks, boulders, fill, old timber, buried trees and roots, abandoned utilities, abandoned foundations and structures, buried debris, or any combination of these, in whatever condition found.

Provide and maintain all sheeting, shoring, and bracing required in shafts and pits, and open cut excavations to insure protection and safety of personnel and to protect adjacent structures, property and work in place. The Contractor shall be responsible for the complete design of all sheeting, shoring, and bracing work. The design shall be appropriate for the soil conditions, shall be of such strength, quality, dimension and spacing as to prevent caving or loss of ground or squeezing within the neat lines of the excavation, and shall effectively restrain movement of the adjacent soil. Prior to installing the sheeting, shoring or bracing, the Contractor shall submit plans for this work to the Engineer for informational purposes only. Sheeting, shoring, and bracing shall conform to the current federal or state regulations for safety.

Excavate as required to perform all boring work to the grades, lines and levels indicated on the Plans and as specified herein. Construct approach trenches, pits and shafts of sufficient length and width to accommodate the equipment being used, the pipe units to be placed and the manpower working. Locate the approach tunnel or working shaft or pit so that it will not unduly interfere with traffic or with the use of adjacent property.

Where required, control the infiltration of groundwater into the excavation. Use dewatering systems to lower the groundwater to below the bottom of the shaft or use other approved methods at no additional cost to the Owner.

Any relocations or removal and replacement of utilities, including gas mains, water mains, services, sewers, irrigation systems, signs, and other miscellaneous items required to construct shafts shall be incidental to the project unless otherwise specified.

Excavation under railroads shall conform to the requirements of the American Railroad Engineering Association (AREA) and the railroad corporation having jurisdiction.

G. Laying Pipe:

Each pipe shall be inspected for defects prior to being lowered into the trench. Inside of pipe and outside of spigot shall be cleaned of any earth or foreign matter.

Proper implements, tools, and facilities satisfactory to the Engineer shall be provided and used by the Contractor for the safe and convenient prosecution of the work. All pipe, fittings, valves, and hydrants shall be carefully lowered into the trench piece by piece by means of an excavator using chains, slings, or other suitable tools or equipment as recommended by the manufacturer, in such a manner as to prevent damage to them and their protective coatings and linings. Under no circumstances shall materials be dropped or dumped into the trench.

New water main construction shall not be connected into the existing system until it has been tested and accepted by the Engineer. The Contractor shall excavate for all bell holes and shall place the bell of the pipe in the excavated bell hole. Pipe shall be laid on the prepared trench bottom with the bell ends facing the direction of laying, unless otherwise directed by the Engineer.

The Contractor shall take every precaution to prevent foreign material from entering the pipe while it is being placed in the line. During laying operations, no debris, tools, clothing or other materials shall be placed in the pipe. At times when pipe laying is not in progress, the open ends of pipe shall be closed by a watertight plug. This provision shall apply during the noon hours as well as overnight. If water is in the trench, the seal shall remain in place until the trench is pumped completely dry.

Pipe shall be jointed as specified elsewhere herein. The pipe shall be secured in place with approved backfill material tamped under it except at the bells. Pipe and fittings which do not allow a sufficient and uniform space for joints shall be removed and replaced with pipe and fittings of proper dimensions to insure such uniform space. Precautions shall be taken to prevent dirt from entering the joint space.

All pipe shall be laid at the correct line and grade as indicated by the grade stakes and offset line. Each pipe, as laid, shall be checked by the Contractor to ensure that this result is obtained. The staking shall be provided by the Engineer. No pipe shall be laid until a cut sheet for that pipe has been approved by the Engineer. The grade as shown on the Plans is that of the top-of-pipe for water main; and, the work must conform to this profile. For water main construction, a variation from the profile grade of two inches with ductile iron pipe, and three inches with reinforced concrete pipe, will be deemed sufficient reason to cause the work to be rejected and re-laid. Water main pipe alignment shall be maintained so as not to vary more than three inches from the correct line. Any pipe found out of line shall be re-laid properly by the Contractor.

Due to conditions in the field, changes to the proposed vertical and horizontal alignment of the proposed water main may become necessary. The Contractor shall, where directed by the Engineer, excavate up to 60 feet in advance of the pipe laying operation to expose existing underground facilities thereby enabling the

Engineer to make alignment decisions. The Contractor is required to realign (re-lay) the water main up to 2 feet vertically and/or horizontally as directed by the Engineer at no extra cost to the project. The excavation in advance of the pipe laying is intended to help eliminate the need for re-laying pipe.

H. Crossing Existing Structures and Facilities:

During the construction it may be necessary to cross under or over certain sewers, drains, culverts, water lines, gas lines, electric lines, fiber optic communication, telecommunication, and other types of underground structures or facilities, known or unknown. The Contractor shall make every effort to prevent damage to such underground structures and facilities. The Contractor shall not intentionally damage or break existing structures or facilities and repair them in order to expedite the water main installation process. Wherever such structures or facilities may inadvertently be disturbed or broken, they shall be restored to a condition that is equal to, or better than, that was encountered prior to the damage. All damaged structures and/or facilities shall be made fully acceptable to the owner and the City, at the Contractor's expense. All crossings shall be made with a minimum of twelve inches of vertical clearance between or alongside existing structures or facilities.

I. Cutting Pipe:

Cutting cast iron or ductile iron pipe for inserting valves, fittings, or closure pieces shall be performed in a neat and workmanlike manner without damage to the pipe or cement lining and so as to leave a smooth end at right angles to the longitudinal axis. Where the type of pipe joint in use is such that it employs push-on assembly to affect the joint seal, the outside of the cut end shall be tapered back 1/8 inch with a coarse file or a portable grinder at an angle of about 30 degrees. The tapering must remove all sharp and/or rough edges which might injure the gasket.

The flame cutting of pipe will not be allowed. Reinforced concrete water main pipe shall not be cut.

J. Setting Water Main Fittings and Accessories:

Valves, fittings, plugs, hydrants, etc. shall be set and joined to pipe in the manner specified in the Section entitled "Making Joints."

Hydrants shall be located as shown on the Plans or as directed by the Engineer in such a manner as to provide complete accessibility and minimize the possibility of damage from vehicles or injury to pedestrians.

Hydrants shall be set to stand plumb with their nozzles parallel to the street and the pumper nozzle facing the street. Hydrants shall be set with pumper nozzles between 18 and 24 inches above finished grade, or as directed in writing by the Engineer.

K. Making Joints:

Mechanical means shall be used for pulling home all rubber-gasket pipes regardless of trench condition where manual means will not result in pushing and holding the pipe home. When a trench box or liner is used, a cable shall be used to pull the joints home and hold them in position.

Where work is performed in wet trenches or trenches with running sand, the Contractor shall provide and use mechanical means for pulling the pipe home in making up the joint and for holding the pipe joints tight until completion of the line. Mechanical means shall consist of a cable placed inside or outside of the pipe with a suitable winch, jack, or come-along for pulling the pipe home and holding the pipe in position.

Where not required by these Specifications, manual means will be acceptable only if the joints can be pushed home and held.

L. Anchorage for Water Main Fittings and Accessories:

All plugs, caps, tees, hydrants, and bends shall be provided with MDOT Grade S2 concrete meeting the requirements of Section 701 of the 2012 MDOT Standard Specifications for Construction reaction backing (thrust block) as shown on the Plans or specified herein. Valves shall be restrained from movement at adjacent sleeves by the use of a closure piece, or thrust ring (full size pipe section cut to fill the gap inside the sleeve to within 1/4") as specified herein.

Reaction backing shall be placed between unexcavated solid ground and the fitting to be anchored. The area of bearing on the pipe and on the ground in each instance shall be that shown on the details or directed by the Engineer. The reaction backing shall, unless otherwise shown or directed, be so placed that the pipe and fitting joints will be accessible for repairs. This shall include adequate protection of any bolts from direct contact with the concrete.

Metal harnesses of tie rods or clamps may not be used instead of concrete reaction backing. Mega-Lug joint restraint systems and restrained, push-on joint, pipe shall be used where connections to existing lines require immediate pressurization, as specified herein.

In the event that the Engineer determines a change in the anchorage or design is required due to unsuitable earth conditions, changes may be ordered by the Engineer.

The use of friction clamps or set-screw type retainer glands for thrust restraint will not be allowed.

M. Casing Pipe Installation

Casing pipe I.D. shall be a minimum of 6-inches larger than the largest O.D. of the water main pipe. Larger diameter casing pipes shall be required where so noted on the plans. Place pipe to the lines and grades indicated on the Plans. Use care to not damage pipe, joints or joint material.

Perform boring or auguring excavation by excavating an opening larger than the outside diameter of the pipe to be installed. The diameter of the excavation shall not exceed the outside diameter of the casing pipe by more than 1-inch. Employ grouting or other methods approved by the Engineer to fill voids within 48 hours of completing the bore.

N. Abandonment or Removal of Water Main:

The Contractor shall abandon or remove water main(s) where shown on the Plans. All work shall be performed in accordance with the Detailed Specification entitled "Water Main and Appurtenances, Remove or Abandon."

O. Water Main Testing:

The water main shall be disinfected and tested by the Contractor in the presence of the Engineer in accordance with the requirements below. The Contractor shall furnish all piping, pumps, hoses, gauges, and other materials and equipment required to carry out the tests using water from the City's water mains. All chlorinated water shall be discharged directly to the sanitary sewer and will not be allowed to be discharged to the ground or any surrounding water course. Any hoses which are needed to direct water from blow-offs and/or hydrants during water main testing and flushing shall be supplied by the Contractor. The City shall furnish and install one inch corporation stops at all necessary locations, at the expense of the Contractor. The tapping of water mains, the installation of all corporation stops, and the operation of valves and hydrants is reserved for City personnel. The Contractor is required to assist in valve and hydrant operation, however. The Contractor shall give the City forty-eight hours prior written notice of intent and desire to test water mains.

P. Bacteriological Testing Sequences:

In the case of all water mains connected to existing facilities, flushing, chlorination and bacteriological testing must precede pressure testing. Where mains can be totally isolated from existing facilities with air gaps or double valves, pressure testing may precede chlorination and bacteriological testing. The normal sequence and time requirements for testing are:

Isolated (Gapped) Water Main	Connected Water Main
1. Fill Main	1. Flush and Swab*
2. Pressure Test	2. Chlorinate
3. Connect One End of Main	3. Wait; 24 hours
4. Flush and Swab*	4. Flush**
5. Chlorinate	5. Wait; 24 hours
6. Wait; 24 hours	6. Bacteriological Samples
7. Flush**	7. Wait; 24 hours
8. Wait; 24 hours	8. Bacteriological Samples
9. Bacteriological Samples	9. Wait; 48 hours
10. Wait; 24 hours	10. Pressure Test (If both sets of Bacteriological samples pass)
11. Bacteriological Samples	11. Flush
12. Wait; 48 hours	12. Wait; 24 hours
13. Make Final Connection(s) – Place in Service (If both sets of bacteriological samples pass)	13. Bacteriological Samples
	14. Wait; 24 hours
	15. Bacteriological Samples
	16. Wait; 48 hours
	17. Place in Service (If both sets of bacteriological samples pass)

*Collect flush water in operable storm water retention/detention facility.

**Discharge flush water into approved sanitary sewer.

The Contractor shall not connect any end of a newly constructed water main to an existing, in-service, water main, until the newly constructed water main passes the hydrostatic test, unless approved in writing by the Engineer.

Q. Hydrostatic (Pressure Test):

Insofar as is practical, mains shall be pressure tested between valves. The maximum length of water main to be tested in any one test shall be 1500 feet. The section of main to be tested shall be slowly filled with potable water and the entrained air within the pipe removed or absorbed and pumped up to a pressure of 150 psi (or other pressure if specified) and the test period shall start immediately thereafter. The lines shall then be maintained under a test pressure of 145-155 psi for a continuous period of three hours by pumping chlorinated (25 ppm) water into the line at frequent intervals. The volume of water so added shall be measured and

considered to represent the leakage from the line under test during the interval. Visible leaks shall be repaired regardless of test results. The leakage under the conditions of the test shall not exceed the values shown in the table below. If one side of a double disc gate valve is under test pressure, that seat shall count as four joints.

Maximum Allowable Leakage per 100 Joints at 150 psi Avg. Test Pressure

Pipe Diameter (Inches)	4	6	8	10	12	16	20	24	30	36
Leakage (gallons/hr)	0.66	0.99	1.32	1.66	1.99	2.65	3.30	3.97	4.97	5.96

In the event that the leakage exceeds the maximum allowable leakage as specified above, the joints in the line shall be carefully inspected for leaks and repaired where necessary. Any pipes or fittings found to be leaking shall be removed and replaced with new pieces by the Contractor. After this work has been performed, all tests shall be repeated.

R. Flushing and Swabbing:

The Contractor shall flush the water main after making a connection to the existing City water main where a valve separates the new water main from the existing main. As a result, flushing will be accomplished using flow through the full size of the new water main. If a storm water retention/detention facility is to be constructed as part of the project, this facility is to be completed, stabilized, operable, and utilized for the collection of the flushing water. All pipe, materials, and appurtenances which will come into contact with potable City water after the restoration of water service following the connection shall be disinfected with a strong chlorine solution prior to installation.

Water main shall be cleaned using a high density poly-pig, Girard Aqua Swab (2 lbs/ft³ density) swab, or Engineer approved equal and flushed. The diameter of the blow-off pipes shall be at least 50% of the diameter of the pipe being flushed. Hydrants, with internal components removed, may serve as blow-offs for mains 12 inches and less. The Contractor shall provide details, for the review and approval of the Engineer, for the various required blow-offs. Blow-off pipes, discharge hoses, where needed, and associated costs shall be included in the cost of the permanent water main being installed and will not be paid for separately. If there are no branch connections to be swabbed, the poly-pig shall be inserted in the new water main at the time of connection described above. The poly-pig shall be located on the "downstream" or new side of the separation valve. The poly-pig shall then be forced through the new water main during the first flush and discharged through a construction blow-off of sufficient size to allow passage of the poly-pig. For water mains with branch connections, a launching tee or wye shall be installed as shown

in the details, for launching multiple poly-pigs. The main line and each branch main shall be flushed and swabbed individually. Following the successful final bacteriological testing of the water main, the launching tee/wye shall be permanently capped at its branch.

During the flushing and swabbing of a water main, the discharge point for the main shall be left open, with all other discharge points closed, to direct the poly-pig completely through the main being swabbed to its point of termination. Following the initial swabbing of water main, the separation valve shall be closed, and then the discharge point closed. If a branch water main is to be swabbed, the poly-pig is then to be placed in the launcher; the discharge point for the branch water main is to be opened; the poly-pig is to be inserted into the water main; the separation valve partially opened and the branch water main flushed and swabbed.

Following the swabbing of the water main(s), the water main(s) are to be flushed as required. If approved or directed by the Engineer, the water main(s) may be flushed overnight, provided that proper controls (i.e. hoses directed into storm structures, etc.) are installed to direct and control the flushing water.

S. Chlorination:

After the water mains to be tested have been acceptably flushed, they shall be disinfected in accordance with AWWA C651 "Disinfecting Water Mains" and these Specifications. All new mains and fittings, and any existing mains contaminated by the Contractor, shall be chlorinated to a minimum residual of fifty (50) parts per million (ppm) with commercial liquid chlorine solution (sodium hypochlorite - pool type). Other forms of chlorination and disinfection methods of water mains may be presented by the Contractor and shall receive prior approval in writing by the Engineer before being used. The minimum recommended dosage of sodium hypochlorite is as follows (based on 10% available chlorine):

Recommended Minimum Chlorine Dosage to Disinfect 100 L.F. of Pipe

Pipe Diameter (inches)	10% Chlorine Solution (gallon)
6	0.153
8	0.272
10	0.426
12	0.613
16	1.090
20	1.703
24	2.452

The chlorinated water shall remain in the mains for a minimum of 24 hours, at the end of which period the chlorinated water at all parts of the main must show free available chlorine residual of at least twenty-five (25) ppm. If less than 25 ppm residual is shown at the end of the first 24 hour period, additional chlorine shall be added until a residual of not less than 25 ppm at all parts of the system is shown after a subsequent 24 hour period. The chlorinated water shall then be removed from the mains and disposed of into an existing, approved City sanitary sewer main, or other location approved in writing by the Engineer. All chlorinated water shall be discharged directly to the sanitary sewer and will not be allowed to be discharged to the ground or any surrounding water course. The mains shall then be left full of water ready for bacteriological testing.

T. Bacteriological Testing:

The City will obtain bacteriological samples of the water in the mains for analysis from testing blow-offs, corporations, or other sampling points as determined acceptable by the City. Samples will be taken after the mains have been satisfactorily chlorinated in accordance with these Specifications, the chlorinated water flushed out and removed, and the mains filled with potable water. The water samples will only be bacteriologically tested at the City's Water Treatment Plant Laboratory; the use of other laboratories or testing locations shall not be allowed or deemed to provide satisfactory test results by the City of Ann Arbor under any circumstance. No samples will be deemed acceptable until they meet all city requirements. If the newly constructed water main is connected at one end to an in-service section of the City water main, and the chlorination precedes pressure testing, the City will also take samples after satisfactory pressure testing. In each case, two sets of samples shall be taken; a period of 24 hours must elapse between flushing of the main and drawing of the first samples, with the second samples being drawn 24 hours after the first samples were drawn. For each sample, a minimum of 48 hours is required to obtain test results. All samples must pass the bacteriological test.

The Contractor shall plan for these testing sequences and durations in his construction schedule. Contract time will continue during all water main testing phases, regardless of duration.

d. Construction, General Requirements.- coordination with the City of Ann Arbor Field Operations Unit for the installation of 1-inch corporations in the gate wells to be used for water main testing and/or filling of new main.

The Contractor must have all materials, fittings, pumps and other miscellaneous equipment, and personnel on-site before the City of Ann Arbor Public Services personnel will prepare and shutdown and existing main.

The bedding and backfill for Trench Detail I (under roadbed), Modified, shall be MDOT Granular Material, Class II compacted to 95% of its maximum dry density in maximum lifts

of 12 inches. The bedding and backfill for Trench Detail V (within 1:1 influence of the roadbed or curb and gutter), Modified, to a point 12 inches above the top of pipe, shall be MDOT Class II sand compacted to 95% of its maximum dry density. The material above this point shall be Engineer-approved native material compacted to 90% of its maximum dry density.

The Contractor shall dig-up and expose all utility crossings prior to laying any water main pipe. This will allow the Engineer to adjust the grade of the water main, if possible, to avoid the existing utilities. The costs of the 'dig-ups', and all related costs, shall be included in the respective items of work in this Detailed Specification. Some "dig-ups" may need to occur out of Phase.

Should the water main, or other pay items in this Detailed Specification, conflict with abandoned sewers or water mains, the conflicting section of the abandoned sewer or water main shall be removed and the remaining sections shall be (re)abandoned in accordance the Detailed Specification for "Water Main and Appurtenances, Abandon" and the Detailed Specification for "Sewer, Any Size or Depth, Abandon," except that flow filling the sewer will not be required. All the work shall be included in the cost of the water main, or other pay items in this Detailed Specification.

e. Lighting Requirements for Nighttime Water Main Work.- Night work shall be lighted to an average intensity of 10 foot-candles minimum. Sufficient light sources shall be provided to achieve this illumination requirement. The lighting scheme shall be submitted to the Engineer for review and approval a minimum of 72 hours prior to the anticipated commencement of the nighttime work. Nighttime work will not be allowed to begin until such time as the lighting scheme has been approved by the Engineer.

The lighting shall allow the inspector to clearly see and inspect all work operations. Light sources shall be adjusted as directed by the Engineer, as many times as needed, in order to meet the requirement.

Lighting systems may be fixed, portable, or equipment mounted. A power source shall be supplied with sufficient capacity to operate the lighting system. The power source shall not violate any local noise ordinance requirements. The lighting system(s) shall be arranged such that they do not interfere with the vision of motorists, glare or shine in the eyes of oncoming drivers, or unnecessarily illuminate surrounding properties or residences. After initial set-up, drive through and observe the lighted area from each direction on the roadway. Adjust lighting units as many times as needed in order to comply with these requirements.

f. Sequence of Construction.- All water main construction shall be completed in accordance with the Detailed Specification entitled "Maintaining Traffic and Construction Sequencing" and as detailed herein. The Contractor shall schedule and coordinate all water main shutdowns with the Engineer. The Contractor shall submit for the Engineer's review and approval the sequence of all water main "shut downs" and tie-ins such that disruption in service to existing properties is minimized to the greatest extent possible. Should the

Engineer not accept the Contractor’s proposed construction sequence, it shall not be a basis of claim for extension of contract time or additional compensation.

All water main and appurtenances shall be pressure tested, cleaned, disinfected and bacteriological tested in accordance with the specifications outlined within this Detailed Specification.

After acceptance of each section of new main the Contractor shall begin coordination with the City of Ann Arbor Public Services Area for the installation of water services, curb stops and boxes in accordance with the Detailed Specification entitled “Excavate and Backfill for Water Service Tap and Lead.”

g. Measurement and Payment.- The completed work will be paid for at the contract unit prices for the following contract items (pay items):

<u>Contract Item (Pay Item)</u>	<u>Pay Unit</u>
Item 284: D.I., CI-56, Water Main, w/ Poly Wrap, ___ inch, Bored in Steel Casing....	Foot
Item 285: PC 350, D.I. Water Main, w/ Poly Wrap, ___ inch, Tr Det I, Mod	Foot
Item 286: ___ deg Bend, ___ inch	Each
Item 287: Reducer, ___ inch x ___ inch	Each
Item 289: Tee, ___ inch x ___ inch x ___ inch	Each
Item 289: Fire Hydrant Assy, w/Extensions, Complete.....	Each
Item 290: Gate Valve-in-Box, ___ inch.....	Each
Item 291: Gate Valve-in-Well, ___ inch.....	Each
Item 292: Tapping Sleeve, ___ inch x ___ inch x ___ inch, Valve and Box	Each

All work shall be paid in full at the contract unit prices which shall include all labor, materials and equipment required including all required costs associated with night time work, supplemental lighting, and all other required elements of the work.

Water main pipe per lineal foot includes restrained joints where called for on the plans.

Water main in bored steel casing includes all excavation, boring pits, sheeting, shoring, bracing, backfilling, casing pipe and water main in casing.

Fittings other than those specifically listed as separate contract items, blow-off assemblies, hoses, and restrained joint pipe and gaskets, special gaskets, and the like, shall not be paid for separately, but shall be considered included in the payment for “PC350, D.I. Water Main, w/Poly Wrap, ___ inch, Tr Det ___.” Tees, Bends, and Reducers and other fittings specifically listed as separate contract items (pay items), shall be paid for at the contract unit price for each unit installed.

Gate Valve-in-Box includes the Valve Box. Valve Box Extensions will only be paid for if they are required by the plans and they are not required due to the Contractor’s operations.

CITY OF ANN ARBOR
SPECIAL PROVISION
FOR
TEMPORARY WATER MAIN LINE STOP

WT:VCM

1 of 6

01/17/19

a. Description.- The Contractor shall furnish all materials, labor and equipment to properly install and set water main line stops into the existing Ductile Iron Main(s) at the locations as shown on the plans and as directed by the Engineer. All work shall be performed in accordance with the requirements as detailed herein.

The existing mains, upstream and downstream of the proposed line stop(s) cannot be shut down or taken out of service. To ensure that the entire operation shall be accomplished without interruption of service or flow, the installation shall be accomplished by Contractor personnel skilled and experienced in the procedures specific to line stops of the required size(s).

The work shall include, but not be limited to; pavement saw-cutting; excavation and disposal of excavated material; the furnishing, installation, and removal of sheeting and/or shoring where needed; the furnishing, placement and compaction of approved bedding and backfill materials; furnishing and placing suitable, clean, gravel to create a stable working surface at the bottom of the excavation; de-watering; pipe cleaning, measuring, and performing all advance work necessary to prepare for the performance of the line stop; nighttime lighting as required; the removal of all materials and equipment associated with the work when no longer needed; backfill, restoration and compaction of subgrade, base and pavement materials, and, any other items needed to complete the work as detailed on the plans and as specified herein.

This work shall also include all traffic maintenance and control items in accordance with the Michigan Manual of Uniform Traffic Control Devices.

b. Materials.- Bedding and backfill for areas contained within a segment of water main designated as Trench Detail I (under roadbed), Modified, shall be Granular Material, Class II, meeting the requirements of Section 902. For work within a segment of water main designated as Trench Detail V (outside of the 1:1 influence line of roadbed or curb and gutter), Modified, Granular Material, Class II and Engineer approved native material, placed in accordance with the trench details, shall be used.

The Contractor shall submit to the Engineer two (2) sets of drawings, furnished by manufacturers, fully and distinctly illustrated and describing the Line Stop fittings proposed to be furnished. Work shall not commence until such time as the drawings have been reviewed and accepted by the Engineer.

Line Stop Fittings shall be full encirclement, pressure retention type split tee. It shall consist of two steel weldments; an upper line stop flange saddle plate and a lower saddle plate. These two saddle plates shall be contiguous.

Line Stop Flange: The outlet of each fitting shall be machined from a 150 lb. forged steel flange (ASTM A181 or A105) or from pressure vessel quality steel plate (ASTM A285, Grade C); flat faced and drilled per ANSI B16.5). Suitable independently operated locking devices shall be provided in the periphery of the flange to secure the completion plug.

Line stop Nozzle: The nozzle, which lies between the saddle and the flange shall be fabricated from steel pipe (ASTM A234). After welding and stress relief, the nozzle shall be accurately bored as follows to accommodate the Line stop plugging head:

- a) Machine an internal circular shoulder to seal against the circumferential gasket carried on the plugging head.

Completion Plug: The completion plug shall be machined from a stress relieved carbon steel weldment. It shall contain two (2) circumferential grooves: one to receive the locking devices from the Line stop flange, and the second to contain a compressible "O" ring to seal pressure tight against the bore of the flange.

Blind Flange: Each Line stop fitting shall be closed with a blind flange. Facing and drilling of the blind flange shall be compatible with that of the Line stop flange. Minimum blind flange thickness shall be that of AWWA Spec. 207, Class D.

Saddle Alignment Marking: Each saddle-half shall be matched and marked with serial numbers, to insure proper alignment in the field.

Fasteners: All bolts, studs, and nuts used on Line stop, drain/equalization fittings, blind flange, and other elements that shall remain upon completion of the work shall be stainless steel and meet the requirements of ASTM F 593.

General: Manufacturer will exercise extreme care to ensure that weldments are of adequate strength, properly shaped, securely reinforced, and free from distortion that could stress the ductile iron main during installation, pressure tapping, or Line stopping operations. All steel shall meet the requirements of ASTM A36, as a minimum. All weldments shall be braced and stress relieved.

Gaskets: Shall be molded from elastomer compounds that resist compression setting and are compatible with water in the 32 to 140 deg. F temperature range.

Upper Line stop Flange Saddle: Shall consist of a saddle plate, a Line stop flange, and a Line Stop nozzle. The interior of the saddle plate, adjacent to and concentric with the O.D. of the nozzle, shall be grooved to retain a gasket which shall seal the saddle plate to the exterior of the ductile iron main. This gasket shall constitute the only seal between the main and the fitting. The flange saddle shall also meet the following requirements:

- a) Saddle plate shall be of a minimum of 0.375" in thickness. It shall be shaped to be concentric to the outside of the ductile iron main. The smallest I.D. of the saddle and its interior rings shall exceed the O.D. of the main by a minimum of 0.250" to allow for ovality of the main;
- b) Line stop nozzle of 0.375" min. wall thickness shall be securely welded to the saddle plate;
- c) The Line Stop flange shall be securely welded to the nozzle. After welding, the assembly shall be braced, stress relieved, and bored to receive the completion plug and the circumferential gasket of the Line Stop machine plugging head; and,
- d) Bolt, nut of stud, nut, and washer assemblies shall be furnished to draw the upper and lower saddles together for sealing. Bolting brackets shall be gusseted.

Lower Saddle Plate: Saddle plate shall be of a minimum 0.375" thickness and shall be shaped to be concentric to the outside brackets shall match upper half.

c. Equipment.- The equipment shall consist of a cylindrical plugging head that contains a flat, expandable elastomer sealing element. The plugging head shall be advanced into and retracted from the main by means of a linear actuator. When retracted, the plugging head and carrier are housed in an adapter, bolted pressure tight between the tapping valve and the actuator.

Sealing Element: The element shall be monolithically molded from a suitable polyurethane compound. The element shall be flat in a plane perpendicular to the flow in the main. Minimum thickness of the element shall be 4". The bottom of the element shall be semi-circular to conform to the bore of the main.

Drilling equipment: Shall be in good working condition, equipped with power drive to insure smooth cutting, and to minimize shock and vibration. Cutting equipment shall be carbide tipped and capable of being replaced without removal from the jobsite.

Plugging Head: The diameter of the cylindrical plugging head shall be slightly smaller than the bore of the Line Stop nozzle. The plugging head shall have a suitable circumferential gasket to seal against the shoulder in the Line stop nozzle. This gasket shall also seal against the sealing element to prevent bypass flow around the Line stop.

Deposits in Bore of Main: The semi-cylindrical bottom of the plugging head shall be designed to break and dislodge tuberculation and other deposits in the bore of the main which might interfere with a satisfactory Line stop.

d. Method of Construction.- Installation of proposed line stops mains will require work in close proximity to existing utilities. This must be taken into consideration when the contractor determines the required trench safety requirements. All excavation shall conform to MIOSHA Standards; the Contractor is solely responsible for determining all excavation and trench safety requirements.

If necessary, The City will reduce the pressure to 100 psig or less for the duration of the installations. The entire operation of installing the line stop shall be accomplished without reduction of water pressure in the main(s) below 100 psig. It shall be the responsibility of the Contractor to verify pressure prior to commencing the installation.

Preliminary Field Inspection of Water Main:

Dimensional, specification, and other data regarding the existing mains have been taken from existing records. This information may be inaccurate, out of date, and/or inadequate. The data have not been verified by field inspections. Further, the water main consists of ductile iron pipe which may contain dimensional and structural flaws. In addition, the Contractor shall anticipate that exterior main conditions, bells, service connections, or presence of adjoining utilities may require relocation of proposed line stop. Prior to proceeding with the installation of any line stop, it is necessary to know the exact main outside diameter of the water main, if it has any ovality, and the internal diameter of the pipe before line stop fittings and plugging head sealing elements can be manufactured and/or ordered.

Prior to ordering material, Contractor shall excavate at each proposed location and carefully measure the outside diameter of the water main with calipers along at least four (4) locations to determine ovality and the critical outside diameter of the water main. The Contractor shall determine main wall thickness, uniformity, and structural integrity by means of ultrasonic testing. Data shall be taken to determine extent of internal deposits, tuberculation, etc.

If the Engineer determines that Contractor's data are not adequate, the Engineer may direct Contractor to make one or more pressure taps on main to obtain test pipe coupons for the Engineer's evaluation. The minimum size of the test coupon shall be 5" diameter, drilled through a nominal 6" valve. Pressure tapping saddles and other materials used for inspection taps shall conform to the requirements of this Special Provision. The Contractor shall anticipate that heavy interior corrosion and/or tuberculation exists within the water main.

If, in Engineer's opinion, the proposed location is unsatisfactory based on measurements of the existing pipe at the locations of the proposed line stops, the Engineer will direct excavation at another site. Excavating, de-watering, inspections, backfill, and restoration will be paid for separately in accordance with the applicable contract unit prices or Section 109.05.C and 109.05.D whichever the Engineer deems most appropriate.

Because of possible internal corrosion and deposits in existing water mains, a "bottle-tight" shut down may not occur. A satisfactory shutdown which allows the work to be accomplished (i.e. valve replacement, water main tie-in, etc.) using drainage pumps to de-water excavations, with workmen wearing boots and raingear, if necessary, must be obtained. The Contractor will not be allowed to proceed with further work until an acceptable shutdown is achieved. The Contractor shall be aware that this may require the halting of work and re-scheduling of all work operations.

Contractor shall power wire brush and grind the exterior of the water main to remove any debris, corrosion deposits, or other surface irregularities that might interfere with proper seating and sealing of each line stop fitting against each main. Any structural defects in the water main, service connections, appurtenances, adjacent utilities, etc., that could interfere with the line stop installation shall be immediately reported to Engineer.

All line stop fittings and appurtenances shall be cleaned and disinfected in accordance with the current City of Ann Arbor Public Services Area Standard Specifications prior to bolting any of the line stop fittings in place or commencing any pipe cutting.

Contractor shall fit upper and lower saddle plate assemblies to main, thoroughly checking for proper fit to main. Under no circumstances shall Contractor attempt to force, reshape, or bend saddle plates by excessive tightening of saddle studs while the line stop fitting is assembled around the main. Any required retrofitting shall be accomplished with the fitting removed from the main. Any damage to fitting, accessories, or main shall be repaired at Contractor's expense to the satisfaction of Engineer.

Upper and Lower saddle halves shall be drawn together by bolt assemblies and the Saddle plates shall be bolted together in the horizontal position.

All line stop work shall be performed in accordance with the equipment manufacturers approved work procedures and installation guidelines.

Final closure of the water main shall be accomplished by insertion of a manufacturer-approved completion plug. The Contractor shall test the completion plug sealing through the use of a bleed off assembly in the machine housing.

The Contractor shall remove the temporary valve and the installation of a blind flange shall be completed.

The Contractor shall place polyethylene encasement meeting the requirements of the City of Ann Arbor Standard Specifications for Construction around the upper and lower saddle halves, the blind flange, and to a point at least 1 foot on either side of the saddle halves. All polyethylene encasement shall be securely taped to the water main such that water entry is minimized to the greatest extent possible.

Lighting Requirements for Nighttime Water Main Work:

Night work shall be lighted to an average intensity of 108 lux minimum. Sufficient light sources shall be provided to achieve this illumination requirement. The lighting scheme shall be submitted to the Engineer for review and approval. Nighttime water main work will not be allowed to begin until such time as the lighting scheme has been approved by the Engineer.

The lighting shall allow the inspector to clearly see and inspect all work operations, including pipe, fitting, and valve installations, disinfection of the pipe, pipe cleaning, and all other night work.

Lighting systems may be fixed, portable, or equipment mounted. A power source shall be supplied with sufficient capacity to operate the lighting system. The lighting system(s) shall be arranged such that they do not interfere with the vision of motorists or unnecessarily illuminate surrounding properties or residences.

e. Measurement and Payment.- The completed work will be paid for at the contract unit prices for the following contract items (pay items):

<u>Contract Item (Pay Item)</u>	<u>Pay Unit</u>
Item 293: Line Stop, Ductile Iron Pipe, __ inch	Each

All work shall be paid in full at the contract unit prices which shall include all the labor, materials, and equipment required to perform the work as detailed herein. This shall also include all required costs associated with night time work, supplemental lighting, and all other required elements of the work, including all traffic maintenance and control.

CITY OF ANN ARBOR
SPECIAL PROVISION
FOR
WATER MAIN AND APPURTENANCES, REMOVE OR ABANDON

WT:VCM

1 of 2

01/17/19

a. Description.- This work shall include abandoning or removing existing water mains, valves, valve wells, valve boxes, and fire hydrant assemblies of various sizes as required by the Plans. All work shall be performed in accordance with the project plans, as detailed in this Special Provision, and as directed by the Engineer.

b. Materials.- All materials shall meet the requirements specified in Division 7 and 9 of the MDOT 2012 Standard Specifications for Construction as follows:

Mortar Type II	Section 702
Granular Material, Class II	Section 902
Masonry Units	Section 913

Push-on joint plugs and thrust blocks shall conform to the requirements as detailed in the Special Provision entitled "Water Main and Appurtenances."

c. Methods of Construction.- The Contractor shall abandon water mains where shown on the Plans and as directed by the Engineer. This includes, but is not limited to, cutting the main at each end, plugging the live main at the end(s) with push-on joint plug(s) and thrust block(s), plugging the abandoned main at its end(s) with brick and mortar, concrete, or mechanical joint plug, breaking down any manholes (remove manhole ring and cover and the top 4' of manhole structure, breaking out the manhole base, and backfilling as specified herein) in the abandoned line, removing and salvaging any valves and fittings, plugging the pipe in manholes with brick and mortar, concrete, or mechanical joint plugs.

In locations as shown on the Plans or where abandoned water main, valves or valve wells are within 30 inches of the proposed subgrade, the pipe, valves or valve wells shall be removed completely. The resulting hole or trench shall be backfilled with Granular Material, Class II, in maximum lifts of 12 inches, and be compacted to 95% of its maximum dry density, if located within the public rights-of-way, railroad rights-of-way, or within the influence of paved surfaces or structures. Applicable road pavement cross-section, per plans, shall be installed per plans and as directed by the Engineer. Otherwise, backfill shall be Engineer approved native material, compacted to 90% of its maximum dry density, in lifts of 12 inches or less, unless otherwise noted on the plans.

Abandoned (salvaged) or removed valves and fire hydrant assemblies shall be neatly stacked on-site in a single location so that City of Ann Arbor forces can retrieve them at a later date. The Contractor shall assist City forces by loading them into City trucks. All costs associated with storing, stockpiling, and loading valves and hydrants into City vehicles will not be paid for separately.

"Tapping Sleeve, Valve and Well, Remove" shall include removal of the tapping sleeve

and valve, reconnecting the ends of the two water mains, and abandoning the valve well.

d. Measurement and Payment.- The completed work as measured shall be paid at the contract unit prices for the following contract items (pay items):

<u>Contract Item (Pay Item)</u>	<u>Pay Unit</u>
Item 294: ___ inch Water Main, Abandon.....	Linear Foot
Item 295: Water Main, Abandon w/Flowable Fill.....	Linear Foot
Item 296: Gate Valve-in-Box, Abandon.....	Each
Item 297: Gate Valve-in-Well, Abandon.....	Each
Item 298: Fire Hydrant, Rem.....	Each
Item 299: Tapping Sleeve, Valve and Well, Remove.....	Each

“___ inch Water Main, Abandon” and “___ inch Water Main, Rem” shall be measured and paid for by length in lineal feet and shall include all labor, materials, and equipment necessary to abandon or remove the pipe including, but not limited to; excavation; cutting of pipe; furnishing and installing push-on joint plugs and thrust blocks; constructing brick and mortar bulkheads; the furnishing, placement, and compaction of approved granular backfill material, as required; and, the removal and proper disposal off-site of excess materials.

“___ inch Gate Valve-in-Box, Abandon”; “___ inch Gate Valve-in-Well, Abandon”; “___ inch Gate Valve-in-Box, Rem”; “___ inch Gate Valve-in-Well, Rem”; and, “Fire Hydrant, Rem” shall be paid for at the contract unit price for each unit abandoned or removed.

“Tapping Sleeve, Valve and Well, Remove” shall include all labor, materials, and equipment necessary to remove the tapping sleeve and valve including, but not limited to; excavation; cutting of pipe; furnishing and installing solid sleeve, plugging end of abandoned pipe, abandoning valve well; the furnishing, placement, and compaction of approved granular backfill material as required; and, the removal and proper disposal off-site of excess materials.

Payment shall include all labor, materials, and equipment necessary to completely abandon or remove the valve, including removing and salvaging the valve, valve boxes, and manhole rings and covers. Also included is the removal of the top 4 feet of valve wells; breaking out the valve well base; furnishing, placement, and compaction of approved granular backfill material, as required; stockpiling valves for future City use or removal; and, the removal and disposal of excess materials. Payment for Fire Hydrant, Rem includes payment for abandoning the companion valve.

APPENDIX



Esri, HERE, DeLorme, MapmyIndia, © OpenStreetMap contributors

◆ 5 Feet Boring (Lithology)



0 200 400 Feet



DESIGNED BY: ADR

DATE: 05/17/2018

CHECKED BY: PJM

DATE: 05/17/2018

BUNDLE 3
ANN ARBOR, MICHIGAN
BORING LOCATIONS
(LOCATIONS GP-18-01 THROUGH GP-18-04)

FIGURE

1



Esri, HERE, DeLorme, MapmyIndia, © OpenStreetMap contributors

- ⊕ 20 Feet Boring (Lithology)
- ◆ 5 Feet Boring (Lithology)
- ⊕ 20 Feet Boring (Environmental)

Notes:

-Soil and groundwater samples were analyzed for Michigan 10 metals, VOCs, SVOCs and PCBs from Environmental Locations.
 -GP-18-09W was only analyzed for Michigan 10 metals, VOCs and PCBs due to limited sample availability.

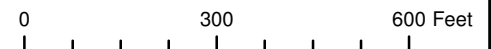

DESIGNED BY: ADR
DATE: 05/18/2018
CHECKED BY: PJM
DATE: 05/18/2018

BUNDLE 3
 ANN ARBOR, MICHIGAN
BORING LOCATIONS
 (LOCATIONS GP-18-05 THROUGH GP-18-19)

FIGURE

2



Tetra Tech
 710 Avis Drive
 Ann Arbor, MI 48108
 Telephone: (734) 213-4030
 Fax: (734) 213-5008

LOG OF: **GP-18-01**
 (1 of 1)

Site: City of Ann Arbor			Drilling Company: Terra Probe Environmental		
Address: Hoover Bundle 3			Driller: Joe Fojtik		
City, State: Ann Arbor, Michigan			Sampling Method: Macrocore		
Northing: NM		Easting: NM		Logged By: MEM	Checked By: PJM
Total Depth: 5'	Elev: NM	Weather: Sunny, 60° F		Start Date: 4/26/18	Finish Date: 4/26/2018
Hole Diameter: 2.25"	PID Model & Lamp eV: MiniRAE 3000 10.6 eV			Sand Pack Interval: na	Bentonite Chip Interval: na
Casing (Interval, Diameter, Type): na		Hole Abandonment: Bentonite Chips		Grout Type & Interval: na	
Groundwater Sample Screen (Interval, Diameter, SLOT Size, Type): na			Location: W. Mosely St, Point #15		

Sample Type/No.	Blow Counts	Rec (%)	SOIL DESCRIPTION	Depth (feet)	PID (ppm)	REMARKS
P-1	73		ASPHALT	0.0	NM	Olfactory observance at top of core.
			Dark brown-black mottled, moist, fine GRAVEL and coarse SAND, with fine to medium Sand, some Clay	0.1	NM	
			Brown, moist CLAY, with Silt, some fine Sand to coarse Gravel	0.2	0.3	
			Brown, moist, fine SAND, with fine to coarse Gravel, medium to coarse Sand and Silt.	0.3	0.0	
			Boring terminated at 5 ft	4		
				6		
				8		
				10		
				12		
				14		
				16		
				18		
				20		

LOG A EWNN07 - GINT STD US.GDT - 5/18/18 13:08 - P:\PROJECTS\ANN ARBOR\GEO\TECHNICAL_PSA.2017\HOOVER BUNDLE 3\GINT\HOOVER BUNDLE 3 BORING LOGS.GPJ



Tetra Tech
 710 Avis Drive
 Ann Arbor, MI 48108
 Telephone: (734) 213-4030
 Fax: (734) 213-5008

LOG OF: **GP-18-02**
 (1 of 1)

Site: City of Ann Arbor			Drilling Company: Terra Probe Environmental		
Address: Hoover Bundle 3			Driller: Joe Fojtik		
City, State: Ann Arbor, Michigan			Sampling Method: Macrocore		
Northing: NM		Easting: NM		Logged By: MEM	Checked By: PJM
Total Depth: 5'	Elev: NM	Weather: Sunny, 60° F		Start Date: 4/26/18	Finish Date: 4/26/2018
Hole Diameter: 2.25"	PID Model & Lamp eV: MiniRAE 3000 10.6 eV			Sand Pack Interval: na	Bentonite Chip Interval: na
Casing (Interval, Diameter, Type): na		Hole Abandonment: Bentonite Chips		Grout Type & Interval: na	
Groundwater Sample Screen (Interval, Diameter, SLOT Size, Type): na			Location: W. Mosely St, Point #16		

Sample Type/No.	Blow Counts	Rec (%)	SOIL DESCRIPTION	Depth (feet)	PID (ppm)	REMARKS
P-1	63		ASPHALT	▲	NM	Olfactory observance at 1'
			Light brown mottled, moist SILT and CLAY, trace fine Gravel and coarse Sand	2	NM	
			Light brown mottled, moist SILT and CLAY, trace medium to coarse Sand	3	0.0	
			Light brown mottled, moist, fine to coarse SAND, with fine to coarse Gravel and Silt	4	0.3	
			Boring terminated at 5 ft	5	0.2	
				6		
				8		
				10		
				12		
				14		
				16		
				18		
				20		

LOG A EWNN07 - GINT STD US.GDT - 5/18/18 13:08 - P:\PROJECTS\ANN ARBOR\GEO\TECHNICAL_PSA.2017\HOOVER BUNDLE 3\GINT\HOOVER BUNDLE 3 BORING LOGS.GPJ



Tetra Tech
 710 Avis Drive
 Ann Arbor, MI 48108
 Telephone: (734) 213-4030
 Fax: (734) 213-5008

LOG OF: **GP-18-03**
 (1 of 1)

Site: City of Ann Arbor			Drilling Company: Terra Probe Environmental		
Address: Hoover Bundle 3			Driller: Joe Fojtik		
City, State: Ann Arbor, Michigan			Sampling Method: Macrocore		
Northing: NM		Easting: NM		Logged By: MEM	Checked By: PJM
Total Depth: 5'	Elev: NM	Weather: Sunny, 60° F		Start Date: 4/26/18	Finish Date: 4/26/2018
Hole Diameter: 2.25"	PID Model & Lamp eV: MiniRAE 3000 10.6 eV			Sand Pack Interval: na	Bentonite Chip Interval: na
Casing (Interval, Diameter, Type): na		Hole Abandonment: Bentonite Chips		Grout Type & Interval: na	
Groundwater Sample Screen (Interval, Diameter, SLOT Size, Type): na			Location: W. Mosely St, Point #17		

Sample Type/No.	Blow Counts	Rec (%)	SOIL DESCRIPTION	Depth (feet)	PID (ppm)	REMARKS
P-1		65	ASPHALT	0		
			Dark gray, moist SILT, with Clay	0.5	NM	
			Dark gray, moist CLAY, some fine to coarse Sand and Silt, trace fine Gravel	2	NM	
			Brown and gray mottled, moist SILT and CLAY, some fine Gravel and coarse Sand	4	1.8 2.7 5.1	
			Boring terminated at 5 ft	6		
				8		
				10		
				12		
				14		
				16		
				18		
				20		

LOG A EWNN07 - GINT STD US.GDT - 5/18/18 13:08 - P:\PROJECTS\ANN ARBOR\GEO\TECHNICAL_PSA.2017\HOOVER BUNDLE 3\GINT\HOOVER BUNDLE 3 BORING LOGS.GPJ



Tetra Tech
 710 Avis Drive
 Ann Arbor, MI 48108
 Telephone: (734) 213-4030
 Fax: (734) 213-5008

LOG OF: **GP-18-04**
 (1 of 1)

Site: City of Ann Arbor			Drilling Company: Terra Probe Environmental		
Address: Hoover Bundle 3			Driller: Joe Fojtik		
City, State: Ann Arbor, Michigan			Sampling Method: Macrocore		
Northing: NM		Easting: NM		Logged By: MEM	Checked By: PJM
Total Depth: 5'	Elev: NM	Weather: Sunny, 60° F		Start Date: 4/26/18	Finish Date: 4/26/2018
Hole Diameter: 2.25"	PID Model & Lamp eV: MiniRAE 3000 10.6eV			Sand Pack Interval: na	Bentonite Chip Interval: na
Casing (Interval, Diameter, Type): na		Hole Abandonment: Bentonite Chips		Grout Type & Interval: na	
Groundwater Sample Screen (Interval, Diameter, SLOT Size, Type): na			Location: Third St, Point #18		

Sample Type/No.	Blow Counts	Rec (%)	SOIL DESCRIPTION	Depth (feet)	PID (ppm)	REMARKS
P-1	77		ASPHALT	0	NM	
			Brown and red-brown mottled, dry, fine to coarse SAND, some fine Gravel	1.5	NM	
			Dark gray, moist CLAY, with Silt, some medium to coarse Sand, few fine to coarse Gravel	2.0	1.5	
				3.0	1.3	
				4.0	0.5	
			Boring terminated at 5 ft	5.0		
				6.0		
				8.0		
				10.0		
				12.0		
				14.0		
				16.0		
				18.0		
				20.0		

LOG A EWNN07 - GINT STD US.GDT - 5/18/18 13:08 - P:\PROJECTS\ANN ARBOR\GEO\TECHNICAL_PSA.2017\HOOVER BUNDLE 3\GINT\HOOVER BUNDLE 3 BORING LOGS.GPJ



Tetra Tech
 710 Avis Drive
 Ann Arbor, MI 48108
 Telephone: (734) 213-4030
 Fax: (734) 213-5008

LOG OF: **GP-18-05**
 (1 of 1)

Site: City of Ann Arbor			Drilling Company: Terra Probe Environmental			
Address: Hoover Bundle 3			Driller: Joe Fojtik			
City, State: Ann Arbor, Michigan			Sampling Method: Dual Rod			
Northing: NM		Easting: NM		Logged By: MEM	Checked By: PJM	
Total Depth: 20'	Elev: NM	Weather: Sunny, 60° F		Start Date: 4/27/18	Finish Date: 4/27/2018	
Hole Diameter: 2.25"	PID Model & Lamp eV: MiniRAE 3000 10.6eV			Sand Pack Interval: na	Bentonite Chip Interval: na	
Casing (Interval, Diameter, Type): na		Hole Abandonment: Bentonite Chips		Grout Type & Interval: na		
Groundwater Sample Screen (Interval, Diameter, SLOT Size, Type): na			Location: Hoover Ave, Point #8			
Sample Type/No.	Blow Counts	Rec (%)	SOIL DESCRIPTION	Depth (feet)	PID (ppm)	REMARKS
P-1		69	ASPHALT	▲	NM	1" PVC Temp Well Screened 15-20' installed at this location
			Black and gray mottled, dry CLAY, some fine to coarse Sand	2	0.0	
			Dark brown, moist CLAY, with fine Sand and Silt, some coarse Gravel and coarse Sand	2	0.0	
P-2		65	Brown, damp, fine to coarse SAND and SILT, some fine to coarse Gravel and Clay	4	0.0	
			Dark brown, moist CLAY, with fine to coarse Sand and Silt	4	0.1	
			Brown, damp, fine SAND and SILT with medium to coarse Sand, some fine to coarse Gravel	6	0.0	
P-3		63		8	0.0	
			Light brown, wet, medium to coarse SAND, with Silt, some fine Gravel and Clay	10	0.0	
				12	0.3	
P-4		58	Brown, saturated, fine to coarse SAND, with Silt, some fine to coarse Gravel	12		GP-18-05-11'-12' (soil sample) @ 9:50
				14	NM	
P-5		46		16	NM	GP-18-05W (Water sample) @ 10:25
			Gray, damp CLAY, some fine to coarse Gravel and fine to coarse Sand	18	0.0	
			Dark gray, damp CLAY, some fine Gravel and coarse Sand	18	0.0	
			Boring terminated at 20 ft	20		

LOG A EWMN07 - GINT STD US.GDT - 5/18/18 13:08 - P:\PROJECTS\ANN ARBOR\GEO\TECHNICAL_PSA_2017\HOOVER BUNDLE 3\GINT\HOOVER BUNDLE 3 BORING LOGS.GPJ



Tetra Tech
 710 Avis Drive
 Ann Arbor, MI 48108
 Telephone: (734) 213-4030
 Fax: (734) 213-5008

LOG OF: **GP-18-06**
 (1 of 1)

Site: City of Ann Arbor			Drilling Company: Terra Probe Environmental		
Address: Hoover Bundle 3			Driller: Joe Fojtik		
City, State: Ann Arbor, Michigan			Sampling Method: Macrocore		
Northing: NM		Easting: NM		Logged By: MEM	Checked By: PJM
Total Depth: 5'	Elev: NM	Weather: Mostly Sunny, 50° F		Start Date: 4/27/18	Finish Date: 4/27/2018
Hole Diameter: 2.25"	PID Model & Lamp eV: MiniRAE 3000 10.6eV			Sand Pack Interval: na	Bentonite Chip Interval: na
Casing (Interval, Diameter, Type): na		Hole Abandonment: Bentonite Chips		Grout Type & Interval: na	
Groundwater Sample Screen (Interval, Diameter, SLOT Size, Type): na			Location: Hoover Ave, Point #9		

Sample Type/No.	Blow Counts	Rec (%)	SOIL DESCRIPTION	Depth (feet)	PID (ppm)	REMARKS
P-1		58	ASPHALT	0.0	NM	
			Dark brown, moist, fine to coarse SAND and SILT, with fine to coarse Gravel and Clay	2.0	0.0	
			Dark brown, moist SILT and CLAY, with fine to coarse Sand, some fine to coarse Gravel	3.0	0.3	
			Brown, moist, fine to coarse SAND and SILT, with Clay, some fine to coarse Gravel	4.0	0.0	
			Boring terminated at 5 ft	6.0		
				8.0		
				10.0		
				12.0		
				14.0		
				16.0		
				18.0		
				20.0		

LOG A EWNN07 - GINT STD US.GDT - 5/18/18 13:08 - P:\PROJECTS\ANN ARBOR\GEO\TECHNICAL_PSA.2017\HOOVER BUNDLE 3\GINT\HOOVER BUNDLE 3 BORING LOGS.GPJ



Tetra Tech
 710 Avis Drive
 Ann Arbor, MI 48108
 Telephone: (734) 213-4030
 Fax: (734) 213-5008

LOG OF: **GP-18-07**
 (1 of 1)

Site: City of Ann Arbor			Drilling Company: Terra Probe Environmental		
Address: Hoover Bundle 3			Driller: Joe Fojtik		
City, State: Ann Arbor, Michigan			Sampling Method: Macrocore		
Northing: NM		Easting: NM		Logged By: MEM	Checked By: PJM
Total Depth: 20'	Elev: NM	Weather: Mostly Sunny, 50° F		Start Date: 4/27/18	Finish Date: 4/27/2018
Hole Diameter: 2.25"	PID Model & Lamp eV: MiniRAE 3000 10.6eV			Sand Pack Interval: na	Bentonite Chip Interval: na
Casing (Interval, Diameter, Type): na		Hole Abandonment: Bentonite Chips		Grout Type & Interval: na	
Groundwater Sample Screen (Interval, Diameter, SLOT Size, Type): na			Location: Greene St, Point #12		

LOG A EWMN07 - GINT STD US.GDT - 5/18/18 13:08 - P:\PROJECTS\ANN ARBOR\GEO\TECHNICAL_PSA.2017\HOOVER BUNDLE 3\GINT\HOOVER BUNDLE 3 BORING LOGS.GPJ

Sample Type/No.	Blow Counts	Rec (%)	SOIL DESCRIPTION	Depth (feet)	PID (ppm)	REMARKS
P-1		102	ASPHALT	0.0	NM	
			Dark to light brown, dry CLAY, with Silt, some fine to medium Sand, few coarse Sand	2.0	0.0	
P-2		52	Brown, dry, fine to medium SAND and SILT, with fine Gravel and coarse Sand, little Clay	4.0	0.0	
			Tan, moist to wet, fine to medium SAND, some coarse Sand, trace fine Gravel	6.0	1.0	
P-3		79		8.0	0.0	
				10.0	0.0	
P-4		79	Tan, saturated, fine to medium SAND, some coarse Sand, trace fine Gravel	12.0	0.0	
			Tan, saturated SILT, with fine Sand and Clay	16.0	NM	
P-5		100	Gray, saturated, coarse to medium SAND, some fine to coarse Gravel, fine Sand and Silt	18.0	NM	
			Boring terminated at 20 ft	20.0		



Tetra Tech
 710 Avis Drive
 Ann Arbor, MI 48108
 Telephone: (734) 213-4030
 Fax: (734) 213-5008

LOG OF: **GP-18-08**
 (1 of 1)

Site: City of Ann Arbor			Drilling Company: Terra Probe Environmental		
Address: Hoover Bundle 3			Driller: Joe Fojtik		
City, State: Ann Arbor, Michigan			Sampling Method: Macrocore		
Northing: NM		Easting: NM		Logged By: MEM	Checked By: PJM
Total Depth: 5'	Elev: NM	Weather: Mostly Sunny, 60° F		Start Date: 4/27/18	Finish Date: 4/27/2018
Hole Diameter: 2.25"	PID Model & Lamp eV: MiniRAE 3000 10.6eV			Sand Pack Interval: na	Bentonite Chip Interval: na
Casing (Interval, Diameter, Type): na		Hole Abandonment: Bentonite Chips		Grout Type & Interval: na	
Groundwater Sample Screen (Interval, Diameter, SLOT Size, Type): na			Location: Hoover Ave, Point #7		

Sample Type/No.	Blow Counts	Rec (%)	SOIL DESCRIPTION	Depth (feet)	PID (ppm)	REMARKS
P-1	52		ASPHALT/ROAD PACK	0.0	NM	
			Brown, damp, fine GRAVEL and fine to coarse SAND, some Silt, little coarse Gravel and Clay	2.0	0.0	
			Boring terminated at 5 ft	4.0	0.0	
				6.0		
				8.0		
				10.0		
				12.0		
				14.0		
				16.0		
				18.0		
				20.0		

LOG A EWNN07 - GINT STD US.GDT - 5/18/18 13:09 - P:\PROJECTS\ANN ARBOR\GEO\TECHNICAL_PSA.2017\HOOVER BUNDLE 3\GINT\HOOVER BUNDLE 3 BORING LOGS.GPJ



Tetra Tech
 710 Avis Drive
 Ann Arbor, MI 48108
 Telephone: (734) 213-4030
 Fax: (734) 213-5008

LOG OF: **GP-18-09**
 (1 of 1)

Site: City of Ann Arbor			Drilling Company: Terra Probe Environmental		
Address: Hoover Bundle 3			Driller: Joe Fojtik		
City, State: Ann Arbor, Michigan			Sampling Method: Dual Rod		
Northing: NM		Easting: NM		Logged By: MES	Checked By: PJM
Total Depth: 8.5'	Elev: NM	Weather: Clear, 50° F		Start Date: 4/30/18	Finish Date: 4/30/2018
Hole Diameter: 2.25"	PID Model & Lamp eV: MiniRAE 3000 10.6eV			Sand Pack Interval: na	Bentonite Chip Interval: na
Casing (Interval, Diameter, Type): na		Hole Abandonment: Soil Cuttings		Grout Type & Interval: na	
Groundwater Sample Screen (Interval, Diameter, SLOT Size, Type): na			Location: Hill St, Point #14		

Sample Type/No.	Blow Counts	Rec (%)	SOIL DESCRIPTION	Depth (feet)	PID (ppm)	REMARKS
P-1	88		ASPHALT	0.0	NM	1" PVC Temp Well Screened 3.5 - 8.5' installed at this location
			Fine to medium SAND with Silt, trace fine Gravel 2" layer of brown, moist CLAY, with Silt at 2.25'	2.0	NM	
			Brown, moist CLAY, with Silt	4.0	0.0	
P-2	50		Brown, moist, fine to medium SAND and CLAY, with Silt	6.0	NM	GP-18-09-6' (Soil Sample) @ 10:00
			Brown, saturated, fine to medium SAND and CLAY, with Silt	8.0	NM	
P-3	100		Refusal met at 8.5 ft Boring terminated at 8.5 ft	8.0	NM	GP-18-09W (Water Sample) @ 10:15
				10.0		
				12.0		
				14.0		
				16.0		
				18.0		
				20.0		

LOG A EWNN07 - GINT STD US.GDT - 5/18/18 13:09 - P:\PROJECTS\ANN ARBOR\GEO\TECHNICAL_PSA 2017\HOVER BUNDLE 3\GINT\HOVER BUNDLE 3 BORING LOGS.GPJ



Tetra Tech
 710 Avis Drive
 Ann Arbor, MI 48108
 Telephone: (734) 213-4030
 Fax: (734) 213-5008

LOG OF: **GP-18-10**
 (1 of 1)

Site: City of Ann Arbor			Drilling Company: Terra Probe Environmental		
Address: Hoover Bundle 3			Driller: Joe Fojtik		
City, State: Ann Arbor, Michigan			Sampling Method: Dual Rod		
Northing: NM		Easting: NM		Logged By: MES	Checked By: PJM
Total Depth: 4'	Elev: NM	Weather: Clear, 50° F		Start Date: 4/30/18	Finish Date: 4/30/2018
Hole Diameter: 2.25"	PID Model & Lamp eV: MiniRAE 3000 10.6eV			Sand Pack Interval: na	Bentonite Chip Interval: na
Casing (Interval, Diameter, Type): na		Hole Abandonment: Soil Cuttings		Grout Type & Interval: na	
Groundwater Sample Screen (Interval, Diameter, SLOT Size, Type): na			Location: Hill St, Point #14		

Sample Type/No.	Blow Counts	Rec (%)	SOIL DESCRIPTION	Depth (feet)	PID (ppm)	REMARKS
P-1		92	ASPHALT	0	NM	
			Brown, moist, fine to medium SAND, with Silt, trace fine Gravel	2	NM	
			Brown, moist CLAY, with fine Sand and Silt	3	0.0	
			Brown, moist, fine to medium SAND and CLAY, with Silt	4	0.0	
			Refusal met at 4 ft Boring terminated at 4 ft	4		
				6		
				8		
				10		
				12		
				14		
				16		
				18		
				20		

LOG A EWNN07 - GINT STD US.GDT - 5/18/18 13:09 - P:\PROJECTS\ANN ARBOR\GEO\TECHNICAL_PSA_2017\HOOVER BUNDLE 3\GINT\HOOVER BUNDLE 3 BORING LOGS.GPJ



Tetra Tech
 710 Avis Drive
 Ann Arbor, MI 48108
 Telephone: (734) 213-4030
 Fax: (734) 213-5008

LOG OF: **GP-18-11**
 (1 of 1)

Site: City of Ann Arbor			Drilling Company: Terra Probe Environmental		
Address: Hoover Bundle 3			Driller: Joe Fojtik		
City, State: Ann Arbor, Michigan			Sampling Method: Dual Rod		
Northing: NM		Easting: NM		Logged By: MES	Checked By: PJM
Total Depth: 20'	Elev: NM	Weather: Clear, 60° F		Start Date: 4/30/18	Finish Date: 4/30/2018
Hole Diameter: 2.25"	PID Model & Lamp eV: MiniRAE 3000 10.6eV			Sand Pack Interval: na	Bentonite Chip Interval: na
Casing (Interval, Diameter, Type): na		Hole Abandonment: Soil Cuttings		Grout Type & Interval: na	
Groundwater Sample Screen (Interval, Diameter, SLOT Size, Type): na			Location: Greene St, Point #10		

Sample Type/No.	Blow Counts	Rec (%)	SOIL DESCRIPTION	Depth (feet)	PID (ppm)	REMARKS
P-1		75	ASPHALT	0.0	NM	
			Gray, dry, fine to coarse SAND, with fine Gravel and Silt	0.0	0.0	
			Brown, moist, fine to coarse SAND, with fine Gravel and Silt	2	0.0	
				4	0.0	
P-2		38		6	0.0	
				0.0	0.0	
				0.0	0.0	
				0.0	0.0	
P-3		50	Abandoned concrete pipe/tile, with red glaze, ~6" diameter	8	0.0	
			Red clay tile, with red glaze	0.0	0.0	
			Brown, moist, fine to coarse SAND, some fine Gravel	10	0.0	
			Brown, wet, fine to coarse SAND, some fine Gravel	12	0.0	
P-4		73	Brown, saturated, fine to coarse SAND, some fine Gravel	12		
			Brown, saturated, fine SAND and SILT	14	NM	
			Brown, saturated, fine to coarse SAND, some fine Gravel	16		
			Brown, saturated, fine SAND and SILT	18		
P-5		85	Brown, saturated, fine to coarse SAND, some fine Gravel	16		
			Brown, saturated, fine SAND and SILT, trace fine Gravel	18	NM	
			Brown, saturated, fine to coarse SAND, with Silt, some fine Gravel	20		
			Brown, saturated, fine to medium SAND, with Silt and Clay			
			Boring terminated at 20 ft			

LOG A EWMN07 - GINT STD US.GDT - 5/18/18 13:09 - P:\PROJECTS\ANN ARBOR\GEO\TECHNICAL_PSA.2017\HOVER BUNDLE 3\GINT\HOVER BUNDLE 3 BORING LOGS.GPJ



Tetra Tech
 710 Avis Drive
 Ann Arbor, MI 48108
 Telephone: (734) 213-4030
 Fax: (734) 213-5008

LOG OF: **GP-18-12**
 (1 of 1)

Site: City of Ann Arbor			Drilling Company: Terra Probe Environmental			
Address: Hoover Bundle 3			Driller: Joe Fojtik			
City, State: Ann Arbor, Michigan			Sampling Method: Dual Rod			
Northing: NM		Easting: NM		Logged By: MES	Checked By: PJM	
Total Depth: 20'	Elev: NM	Weather: Clear, 60° F		Start Date: 4/30/18	Finish Date: 4/30/2018	
Hole Diameter: 2.25"	PID Model & Lamp eV: MiniRAE 3000 10.6eV			Sand Pack Interval: na	Bentonite Chip Interval: na	
Casing (Interval, Diameter, Type): na		Hole Abandonment: Soil Cuttings		Grout Type & Interval: na		
Groundwater Sample Screen (Interval, Diameter, SLOT Size, Type): na			Location: Hoover Ave, Point #6			
Sample Type/No.	Blow Counts	Rec (%)	SOIL DESCRIPTION	Depth (feet)	PID (ppm)	REMARKS
P-1		94	ASPHALT	0.0	NM	1" PVC Temp Well Screened 12.5-17.5' installed at this location
			Gray, dry, fine to coarse SAND, with fine Gravel and Silt	0.5	NM	
			Brown, damp, fine to coarse SAND, with Silt	1.5	NM	
			Dark brown, moist, fine to medium SAND, with coarse Sand and Silt, little fine Gravel	2.0	3.6	
P-2		60	Dark brown, moist CLAY, little fine Gravel	2.5		GP-18-12W (Water Sample) @ 14:20
			Brown, moist CLAY, some fine to coarse Sand and Silt	3.5	4.4	
			Brown, moist, fine to coarse SAND and CLAY, with Silt	4.5	0.0	
			Brown, moist SILT and CLAY, little fine Sand	5.5	0.0	
P-3		88	Gray, moist SILT and CLAY, little fine SAND	6.5	0.0	GP-18-12-11-12' (Soil Sample) @ 13:50
			Gray, wet SILT, some fine Sand and Clay	7.5	0.0	
			Gray, saturated, fine SAND, with Silt	8.5	0.0	
P-4		100	Gray, moist SILT and CLAY	9.5	0.0	
			Gray, saturated, fine SAND, with Silt	10.5	0.0	
			Gray, saturated, fine SAND, with Silt	11.5	0.0	
P-5		98	Gray, saturated, fine SAND, with Silt	12.5	NM	
			Gray, saturated, fine SAND, with Silt	13.5	0.0	
			Gray, saturated, fine SAND, with Silt	14.5	0.0	
			Gray, saturated, fine to medium SAND	15.5	0.0	
			Gray, saturated, fine SAND and SILT	16.5	0.0	
			Gray, saturated, fine SAND and SILT	17.5	0.0	
			Boring terminated at 20 ft	18.5	NM	
				19.5		
				20.0		

LOG A EWMN07 - GINT STD US.GDT - 5/18/18 13:09 - P:\PROJECTS\ANN ARBOR\GEO\TECHNICAL_PSA_2017\HOOVER BUNDLE 3\GINT\HOOVER BUNDLE 3 BORING LOGS.GPJ



Tetra Tech
 710 Avis Drive
 Ann Arbor, MI 48108
 Telephone: (734) 213-4030
 Fax: (734) 213-5008

LOG OF: **GP-18-13**
 (1 of 1)

Site: City of Ann Arbor			Drilling Company: Terra Probe Environmental		
Address: Hoover Bundle 3			Driller: Joe Fojtik		
City, State: Ann Arbor, Michigan			Sampling Method: Dual Rod		
Northing: NM		Easting: NM		Logged By: MES	Checked By: PJM
Total Depth: 5'	Elev: NM	Weather: Clear, 60° F		Start Date: 5/1/2018	Finish Date: 5/1/2018
Hole Diameter: 2.25"	PID Model & Lamp eV: MiniRAE 3000 10.6eV			Sand Pack Interval: na	Bentonite Chip Interval: na
Casing (Interval, Diameter, Type): na		Hole Abandonment: Soil Cuttings		Grout Type & Interval: na	
Groundwater Sample Screen (Interval, Diameter, SLOT Size, Type): na			Location: Hoover Ave, Point #4		

Sample Type/No.	Blow Counts	Rec (%)	SOIL DESCRIPTION	Depth (feet)	PID (ppm)	REMARKS
P-1		83	ASPHALT	▲	NM	
			Brown, dry, fine to coarse SAND, with fine Gravel and Silt		0.0	
			Brown, damp, fine to medium SAND	2	0.0	
			Gray-brown, damp CLAY, some Silt	4	0.0	
			Boring terminated at 5 ft	6		
				8		
				10		
				12		
				14		
				16		
				18		
				20		

LOG A EWNN07 - GINT STD US.GDT - 5/18/18 13:09 - P:\PROJECTS\ANN ARBOR\GEO\TECHNICAL_PSA_2017\HOOVER BUNDLE 3\GINT\HOOVER BUNDLE 3 BORING LOGS.GPJ



Tetra Tech
 710 Avis Drive
 Ann Arbor, MI 48108
 Telephone: (734) 213-4030
 Fax: (734) 213-5008

LOG OF: **GP-18-14**
 (1 of 1)

Site: City of Ann Arbor			Drilling Company: Terra Probe Environmental			
Address: Hoover Bundle 3			Driller: Joe Fojtik			
City, State: Ann Arbor, Michigan			Sampling Method: Dual Rod			
Northing: NM		Easting: NM		Logged By: MES	Checked By: PJM	
Total Depth: 20'	Elev: NM	Weather: Clear, 60° F		Start Date: 5/1/2018	Finish Date: 5/1/2018	
Hole Diameter: 2.25"	PID Model & Lamp eV: MiniRAE 3000 10.6eV			Sand Pack Interval: na	Bentonite Chip Interval: na	
Casing (Interval, Diameter, Type): na		Hole Abandonment: Soil Cuttings		Grout Type & Interval: na		
Groundwater Sample Screen (Interval, Diameter, SLOT Size, Type): na			Location: Hoover Ave, Point #5			
Sample Type/No.	Blow Counts	Rec (%)	SOIL DESCRIPTION	Depth (feet)	PID (ppm)	REMARKS
P-1		88	ASPHALT	▲	NM	1" PVC Temp Well Screened 14-19' installed at this location
			Brown, dry, fine to coarse SAND, some fine Gravel and Silt		0.0	
			Brown, damp, fine to medium SAND	2	0.7	
			Brown, damp CLAY, little fine Gravel and Silt, trace fine to medium Sand		0.4	
			Brown, damp CLAY, some Silt, trace fine Sand	4	0.0	
P-2		56			0.0	
					0.0	
				6	0.0	
				8	0.0	
				10	0.0	
P-3		88			0.0	
					0.0	
				12	0.0	
				14	0.0	
				16	0.0	
P-4		94	Gray, moist CLAY		0.0	GP-18-14-14-15' (Soil Sample) @ 9:50
			Gray, wet, fine to medium SAND		0.0	
			Gray, saturated, fine to medium SAND	▽	0.0	
P-5		98			NM	GP-18-14W (Water Sample) @ 10:20
				18		
			Boring terminated at 20 ft	20		

LOG A EWMN07 - GINT STD US.GDT - 5/18/18 13:09 - P:\PROJECTS\ANN ARBOR\GEO\TECHNICAL_PSA.2017\HOOVER BUNDLE 3\GINT\HOOVER BUNDLE 3 BORING LOGS.GPJ



Tetra Tech
 710 Avis Drive
 Ann Arbor, MI 48108
 Telephone: (734) 213-4030
 Fax: (734) 213-5008

LOG OF: **GP-18-15**
 (1 of 1)

Site: City of Ann Arbor			Drilling Company: Terra Probe Environmental			
Address: Hoover Bundle 3			Driller: Joe Fojtik			
City, State: Ann Arbor, Michigan			Sampling Method: Dual Rod			
Northing: NM		Easting: NM		Logged By: MES		Checked By: PJM
Total Depth: 20'	Elev: NM	Weather: Clear, 60° F		Start Date: 5/1/2018	Finish Date: 5/1/2018	
Hole Diameter: 2.25"	PID Model & Lamp eV: MiniRAE 3000 10.6eV			Sand Pack Interval: na	Bentonite Chip Interval: na	
Casing (Interval, Diameter, Type): na			Hole Abandonment: Soil Cuttings		Grout Type & Interval: na	
Groundwater Sample Screen (Interval, Diameter, SLOT Size, Type): na			Location: Keech Ave, Point #11			
Sample Type/No.	Blow Counts	Rec (%)	SOIL DESCRIPTION	Depth (feet)	PID (ppm)	REMARKS
P-1		81	ASPHALT	▲	NM	
			Gray, dry, fine to coarse SAND, with fine Gravel and Silt		0.0	
			Brown, moist CLAY, with fine to coarse Sand and Silt, little fine Gravel	2	0.0	
			Brown, moist CLAY	4	0.0	
P-2		50	Brown, moist, fine to coarse SAND, with fine Gravel, some Silt		0.0	
			Dark brown, moist CLAY, some Silt, little fine Gravel and coarse Sand	6	0.0	
			Brown-gray, moist, fine SAND, with Silt and Clay	8	0.0	
P-3		63	Brown-gray, moist CLAY, with fine Sand and Silt		0.0	
			Brown, moist, fine to medium SAND, little fine Gravel and coarse Sand	10	0.0	
			Brown, saturated, fine to medium SAND, some fine Gravel and coarse Sand	12	NM	
P-4		73	2" layers of brown, moist SILT and CLAY at 15' and 15.5'			
				14	NM	
P-5		75		16		
				18	NM	
			Boring terminated at 20 ft	20		

LOG A EWMN07 - GINT STD US.GDT - 5/18/18 13:09 - P:\PROJECTS\ANN ARBOR\GEO\TECHNICAL_PSA.2017\HOOVER BUNDLE 3\GINT\HOOVER BUNDLE 3 BORING LOGS.GPJ



Tetra Tech
 710 Avis Drive
 Ann Arbor, MI 48108
 Telephone: (734) 213-4030
 Fax: (734) 213-5008

LOG OF: **GP-18-16**
 (1 of 1)

Site: City of Ann Arbor			Drilling Company: Terra Probe Environmental		
Address: Hoover Bundle 3			Driller: Joe Fojtik		
City, State: Ann Arbor, Michigan			Sampling Method: Dual Rod		
Northing: NM		Easting: NM		Logged By: MES	Checked By: PJM
Total Depth: 5'	Elev: NM	Weather: Clear, 60° F		Start Date: 5/1/2018	Finish Date: 5/1/2018
Hole Diameter: 2.25"	PID Model & Lamp eV: MiniRAE 3000 10.6eV			Sand Pack Interval: na	Bentonite Chip Interval: na
Casing (Interval, Diameter, Type): na		Hole Abandonment: Soil Cuttings		Grout Type & Interval: na	
Groundwater Sample Screen (Interval, Diameter, SLOT Size, Type): na			Location: Hill St, Point #13		

Sample Type/No.	Blow Counts	Rec (%)	SOIL DESCRIPTION	Depth (feet)	PID (ppm)	REMARKS
P-1		75	ASPHALT	▲	NM	
			Dark Brown, moist, fine SAND and SILT		0.0	
			Brown, moist, fine to medium SAND, some coarse Sand, trace fine Gravel	2	0.0	
			Dark brown, moist CLAY, with fine to medium Sand, little coarse Sand and Silt		0.0	
			Brown, moist, fine to medium SAND and CLAY, some Silt	4	0.0	
			Light gray, moist CLAY			
			Fine SAND, with Silt in cutting shoe at 5'	6		
			Boring terminated at 5 ft			
				8		
				10		
				12		
				14		
				16		
				18		
				20		

LOG A EWNN07 - GINT STD US.GDT - 5/18/18 13:09 - P:\PROJECTS\ANN ARBOR\GEO\TECHNICAL_PSA_2017\HOOVER BUNDLE 3\GINT\HOOVER BUNDLE 3 BORING LOGS.GPJ



Tetra Tech
 710 Avis Drive
 Ann Arbor, MI 48108
 Telephone: (734) 213-4030
 Fax: (734) 213-5008

LOG OF: **GP-18-17**
 (1 of 1)

Site: City of Ann Arbor			Drilling Company: Terra Probe Environmental			
Address: Hoover Bundle 3			Driller: Joe Fojtik			
City, State: Ann Arbor, Michigan			Sampling Method: Air Knife and Dual Rod			
Northing: NM		Easting: NM		Logged By: MES	Checked By: PJM	
Total Depth: 20'	Elev: NM	Weather: Partly Cloudy, 60° F		Start Date: 5/2/2018	Finish Date: 5/2/2018	
Hole Diameter: 2.25"	PID Model & Lamp eV: MiniRAE 3000 10.6eV			Sand Pack Interval: na	Bentonite Chip Interval: na	
Casing (Interval, Diameter, Type): na		Hole Abandonment: Soil Cuttings		Grout Type & Interval: na		
Groundwater Sample Screen (Interval, Diameter, SLOT Size, Type): na			Location: Hoover Ave, Point #1			
Sample Type/No.	Blow Counts	Rec (%)	SOIL DESCRIPTION	Depth (feet)	PID (ppm)	REMARKS
Air Knife	100		ASPHALT	▲	NM	
			Light brown, moist, fine to medium SAND, some fine Gravel and coarse Sand, little Silt	2	NM	
			Dark brown, moist, fine to medium SAND, some Silt		0.0	
HA	100		Dark brown, moist CLAY, with Silt		0.0	
Air Knife	100		Brown, moist, fine to medium SAND, some Silt, little Clay	4	0.0	
				6	0.0	
P-1	42		Dark brown, fine to coarse SAND, with Silt		0.0	
			Orange-brown, moist, fine to medium SAND, with Silt		0.0	
			Brown, moist, fine GRAVEL and fine to coarse SAND		0.0	
P-2	69		Gray, moist CLAY	8	0.0	
				10	0.0	
			Gray, saturated, fine SAND and SILT		0.0	
P-3	100		Gray, saturated, fine to coarse SAND	12		
			Gray, wet CLAY	14	NM	
			Gray, saturated, fine SAND and SILT			
P-4			Gray, saturated, fine to medium SAND	16		
				18	NM	
			Gray, wet CLAY, with Silt			
			Gray, saturated SILT, with Clay			
			Boring terminated at 20 ft	20		

LOG A EWMN07 - GINT STD US.GDT - 5/18/18 13:09 - P:\PROJECTS\ANN ARBOR\GEO\TECHNICAL_PSA_2017\HOOVER BUNDLE 3\GINT\HOOVER BUNDLE 3 BORING LOGS.GPJ



Tetra Tech
 710 Avis Drive
 Ann Arbor, MI 48108
 Telephone: (734) 213-4030
 Fax: (734) 213-5008

LOG OF: **GP-18-18**
 (1 of 1)

Site: City of Ann Arbor			Drilling Company: Terra Probe Environmental		
Address: Hoover Bundle 3			Driller: Joe Fojtik		
City, State: Ann Arbor, Michigan			Sampling Method: Air Knife and Dual Rod		
Northing: NM		Easting: NM		Logged By: MES	Checked By: PJM
Total Depth: 20'	Elev: NM	Weather: Partly Cloudy, 60° F		Start Date: 5/2/2018	Finish Date: 5/2/2018
Hole Diameter: 2.25"	PID Model & Lamp eV: MiniRAE 3000 10.6eV			Sand Pack Interval: na	Bentonite Chip Interval: na
Casing (Interval, Diameter, Type): na		Hole Abandonment: Soil Cuttings		Grout Type & Interval: na	
Groundwater Sample Screen (Interval, Diameter, SLOT Size, Type): na			Location: Hoover Ave, Point #2		

LOG A EWNN07 - GINT STD US.GDT - 5/18/18 13:09 - P:\PROJECTS\ANN ARBOR\GEO\TECHNICAL_PSA.2017\HOOVER BUNDLE 3\GINT\HOOVER BUNDLE 3 BORING LOGS.GPJ

Sample Type/No.	Blow Counts	Rec (%)	SOIL DESCRIPTION	Depth (feet)	PID (ppm)	REMARKS
Air Knife		100	ASPHALT	0	NM	
			Light brown, damp, fine to medium SAND, some coarse Sand	2	0.0	
HA		100	Dark gray, damp CLAY	4	0.0	
				6	0.0	
P-1		97	Brown, damp CLAY	8	0.0	
				10	0.0	
P-2		81	Gray-brown, moist to wet CLAY	12	0.0	
				14	0.0	
P-3		98	Gray, wet, fine to medium SAND	16	NM	
			Gray, saturated, fine to medium SAND	18	NM	
P-4		100	Gray, wet SILT and CLAY	18	NM	
			Gray, saturated, fine to medium SAND	19	NM	
			Gray, saturated SILT with fine Sand, little Clay	20	NM	
			Gray, wet CLAY	20	NM	
			Gray, saturated, fine SAND, with Silt			
			Gray, wet CLAY			
			Gray, saturated, fine SAND			
			Boring terminated at 20 ft			



Tetra Tech
 710 Avis Drive
 Ann Arbor, MI 48108
 Telephone: (734) 213-4030
 Fax: (734) 213-5008

LOG OF: **GP-18-19**
 (1 of 1)

Site: City of Ann Arbor			Drilling Company: Terra Probe Environmental		
Address: Hoover Bundle 3			Driller: Joe Fojtik		
City, State: Ann Arbor, Michigan			Sampling Method: Dual Rod		
Northing: NM		Easting: NM		Logged By: MES	Checked By: PJM
Total Depth: 20'	Elev: NM	Weather: Partly Cloudy, 60° F		Start Date: 5/2/2018	Finish Date: 5/2/2018
Hole Diameter: 2.25"	PID Model & Lamp eV: MiniRAE 3000 10.6eV			Sand Pack Interval: na	Bentonite Chip Interval: na
Casing (Interval, Diameter, Type): na		Hole Abandonment: Soil Cuttings		Grout Type & Interval: na	
Groundwater Sample Screen (Interval, Diameter, SLOT Size, Type): na			Location: Hoover Ave, Point #3		

Sample Type/No.	Blow Counts	Rec (%)	SOIL DESCRIPTION	Depth (feet)	PID (ppm)	REMARKS
P-1		94	ASPHALT	▲	NM	
			Brown, dry, fine to coarse SAND, with fine Gravel, little Silt		0.0	
			Brown, damp, fine to medium SAND		0.0	
			Brown, damp CLAY		0.0	
			Brown, moist CLAY, with fine to coarse Sand, some Silt		0.0	
P-2		48	Brown, damp, fine to medium SAND, some coarse Sand and Silt	5	0.0	
			Brown, moist CLAY		0.0	
P-3		60	Brown-gray, moist CLAY		NM	
			Gray, moist to wet SILT and CLAY		NM	
				10	NM	
					NM	
P-4		100	Gray, saturated, fine to medium SAND		NM	
			Gray, saturated, fine SAND		NM	
			Gray, saturated, fine to medium SAND		NM	
			Gray, saturated, fine SAND	15	NM	
			Gray, wet SILT, some fine Sand		NM	
P-5		100	Gray, saturated, fine to medium SAND		NM	
			Gray, saturated, fine SAND, with Silt		NM	
			Gray, wet CLAY		NM	
			Gray, saturated, fine to medium SAND		NM	
			Gray, moist CLAY		NM	
			Gray, saturated, fine SAND	20		
			Boring terminated at 20 ft			

LOG A EWNN07 - GINT STD US.GDT - 5/18/18 13:09 - P:\PROJECTS\ANN ARBOR\GEO\TECHNICAL_PSA_2017\HOOVER BUNDLE 3\GINT\HOOVER BUNDLE 3 BORING LOGS.GPJ



Esri, HERE, DeLorme, MapmyIndia, © OpenStreetMap contributors

- ⊕ 20 Feet Boring (Lithology)
- ⊕ 5 Feet Boring (Lithology)
- ⊕ 20 Feet Boring (Environmental)

Notes:
 -Soil and groundwater samples were analyzed for Michigan 10 metals, VOCs, SVOCs and PCBs from Environmental Locations.
 -GP-18-09W was only analyzed for Michigan 10 metals, VOCs and PCBs due to limited sample availability.
 -Analytical results above relevant Part 201 criteria are depicted above.

As = Arsenic Se= Selenium mg/kg = micrograms per kilogram
 Cu = Copper Zn = Zinc ug/l = micrograms per liter
 Pb = Lead

DW = Residential Drinking Water Criteria
 NDW = Nonresidential Drinking Water Criteria
 GSI = Groundwater Surface Water Interface Criteria
 DWP = Residential Drinking Water Protection Criteria
 GSIP = Groundwater Surface Water Interface Protection Criteria

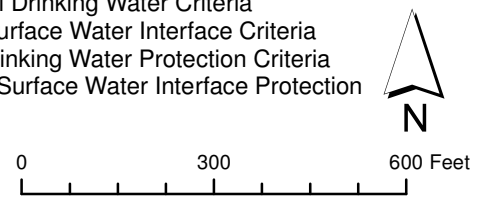

DESIGNED BY: ADR
DATE: 05/22/2018
CHECKED BY: PJM
DATE: 05/22/2018

BUNDLE 3
 ANN ARBOR, MICHIGAN
ANALYTICAL RESULTS

Table 2
Bundle 3 Groundwater Analytical Results
Ann Arbor, Michigan

Sample ID	CAS	Parameter	Result (ug/L)	Residential Drinking Water Criteria And RBSLs	Nonresidential Drinking Water Criteria And RBSLs	Groundwater Surface Water Interface Criteria And RBSLs	Residential Groundwater Volatilization to Indoor Air Inhalation	Nonresidential Groundwater Volatilization to Indoor Air Inhalation	Water Solubility	Flammability and Explosivity Screening Level	
GP-18-05W 4/27/2018	Metals										
	7440-38-2	Arsenic	3.1 J	10 (A)	10 (A)	10	NLV	NLV	NA	ID	
	7440-39-3	Barium	400	2,000 (A)	2,000 (A)	670 (G)	NLV	NLV	NA	ID	
	7440-43-9	Cadmium	0.1 J	5.0 (A)	5.0 (A)	3.0 (G,X)	NLV	NLV	NA	ID	
	7440-47-3	Chromium	3.2 J	100 (A)	100 (A)	11	NLV	NLV	NA	ID	
	7440-50-8	Copper	4.3 J	1,000 (E)	1,000 (E)	13 (G)	NLV	NLV	NA	ID	
	7439-92-1	Lead	2.0 J	4.0 (L)	4.0 (L)	29 (G,X)	NLV	NLV	NA	ID	
	7782-49-2	Selenium	1.5 J	50 (A)	50 (A)	5	NLV	NLV	NA	ID	
7440-66-6	Zinc	13	2,400	5,000 (E)	170 (G)	NLV	NLV	NA	ID		
GP-18-09W 4/30/2018	Metals										
	7440-38-2	Arsenic	23	10 (A)	10 (A)	10	NLV	NLV	NA	ID	
	7440-39-3	Barium	410	2,000 (A)	2,000 (A)	670 (G)	NLV	NLV	NA	ID	
	7440-43-9	Cadmium	1.1 J	5.0 (A)	5.0 (A)	3.0 (G,X)	NLV	NLV	NA	ID	
	7440-47-3	Chromium	32	100 (A)	100 (A)	11	NLV	NLV	NA	ID	
	7440-50-8	Copper	80	1,000 (E)	1,000 (E)	13 (G)	NLV	NLV	NA	ID	
	7439-92-1	Lead	150	4.0 (L)	4.0 (L)	29 (G,X)	NLV	NLV	NA	ID	
	7782-49-2	Selenium	9.4	50 (A)	50 (A)	5	NLV	NLV	NA	ID	
	7440-22-4	Silver	0.18 J	34	98	0.2 (M)	0.06	NLV	NLV	NA	ID
	7440-66-6	Zinc	220	2,400	5,000 (E)	170 (G)	NLV	NLV	NA	ID	
	VOCs										
91-20-3	Naphthalene	1.9 J	520	1,500	11	31,000 (S)	31,000 (S)	31,000	NA	NA	
GP-18-12W 4/30/2018	7440-38-2	Arsenic	8.5	10 (A)	10 (A)	10	NLV	NLV	NA	ID	
	7440-39-3	Barium	340	2,000 (A)	2,000 (A)	670 (G)	NLV	NLV	NA	ID	
	7440-43-9	Cadmium	0.18 J	5.0 (A)	5.0 (A)	3.0 (G,X)	NLV	NLV	NA	ID	
	7440-47-3	Chromium	19	100 (A)	100 (A)	11	NLV	NLV	NA	ID	
	7440-50-8	Copper	48	1,000 (E)	1,000 (E)	13 (G)	NLV	NLV	NA	ID	
	7439-92-1	Lead	17	4.0 (L)	4.0 (L)	29 (G,X)	NLV	NLV	NA	ID	
	7782-49-2	Selenium	1.7 J	50 (A)	50 (A)	5	NLV	NLV	NA	ID	
	7440-66-6	Zinc	53	2,400	5,000 (E)	73 (G)	NLV	NLV	NA	ID	
SVOCs											
84-74-2	Di-n-butyl phthalate	0.27 J	880	2,500	9.7	NLV	NLV	11,200	NA	NA	



CORE LOG

Project: Geotechnical Bundle #2
 TTL Project No. 1504703
 Core Date: December 14 & 15, 2018

828 Greene Street at Centerline		1008 Greene Street in Northbound Lane	
Core Thickness	5 inches	Core Thickness	5 inches
Base Materials	Natural Aggregate with Asphalt Millings	Base Materials	Natural Aggregate

CORE LOG

Project: Geotechnical Bundle #2
TTL Project No. 1504703
Core Date: December 14 & 15, 2018

200 Hill Street in Westbound Lane		Hill Street in Eastbound Lane	
			
Core Thickness	7 inches	Core Thickness	11¼ inches
Base Materials	Natural Aggregate	Base Materials	Limestone Aggregate

CORE LOG

Project: Geotechnical Bundle #2
TTL Project No. 1504703
Core Date: December 14 & 15, 2018

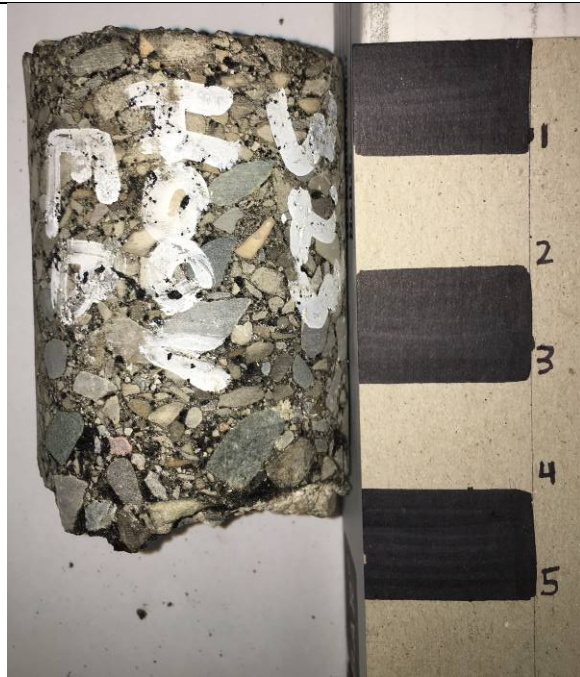
142 Hoover Street in Southbound Lane		323 Hoover Street in Eastbound Lane	
			
Core Thickness	3 ³ / ₄ inches (Measured 4 inches along corehole sidewall)	Core Thickness	4 ¹ / ₄ inches (Measured 4 ¹ / ₂ inches along corehole sidewall)
Base Materials	Natural Aggregate	Base Materials	Limestone Aggregate

CORE LOG

Project: Geotechnical Bundle #2
TTL Project No. 1504703
Core Date: December 14 & 15, 2018

500 Hoover Street in Westbound Lane

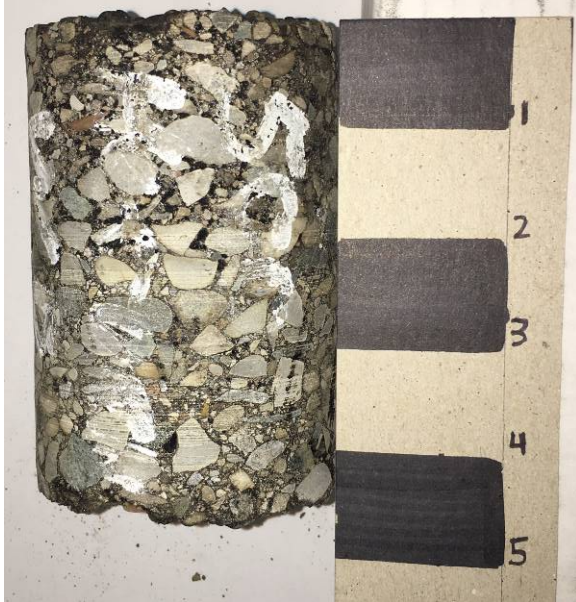

319 Mosley Street in Eastbound Lane



Core Thickness	4¾ inches	Core Thickness	4 inches
Base Materials	Limestone Aggregate	Base Materials	Natural Aggregate

CORE LOG

Project: Geotechnical Bundle #2
TTL Project No. 1504703
Core Date: December 14 & 15, 2018

620 Third Street at Centerline

	
Core Thickness	7¼ inches (Measured 8 inches along corehole sidewall)
Base Materials	Natural Aggregate

ATTACHMENTS

CITY OF ANN ARBOR
LIVING WAGE ORDINANCE DECLARATION OF COMPLIANCE

The Ann Arbor Living Wage Ordinance (Section 1:811-1:821 of Chapter 23 of Title I of the Code) requires that an employer who is (a) a contractor providing services to or for the City for a value greater than \$10,000 for any twelve-month contract term, or (b) a recipient of federal, state, or local grant funding administered by the City for a value greater than \$10,000, or (c) a recipient of financial assistance awarded by the City for a value greater than \$10,000, shall pay its employees a prescribed minimum level of compensation (i.e., Living Wage) for the time those employees perform work on the contract or in connection with the grant or financial assistance. The Living Wage must be paid to these employees for the length of the contract/program.

Companies employing fewer than 5 persons and non-profits employing fewer than 10 persons are exempt from compliance with the Living Wage Ordinance. If this exemption applies to your company/non-profit agency please check here No. of employees _____

The Contractor or Grantee agrees:

- (a) To pay each of its employees whose wage level is not required to comply with federal, state or local prevailing wage law, for work covered or funded by a contract with or grant from the City, no less than the Living Wage. The current Living Wage is defined as \$13.22/hour for those employers that provide employee health care (as defined in the Ordinance at Section 1:815 Sec. 1 (a)), or no less than \$14.75/hour for those employers that do not provide health care. The Contractor or Grantor understands that the Living Wage is adjusted and established annually on April 30 in accordance with the Ordinance and covered employers shall be required to pay the adjusted amount thereafter to be in compliance with Section 1:815(3).

Check the applicable box below which applies to your workforce

Employees who are assigned to any covered City contract/grant will be paid at or above the applicable living wage without health benefits

Employees who are assigned to any covered City contract/grant will be paid at or above the applicable living wage with health benefits

- (a) To post a notice approved by the City regarding the applicability of the Living Wage Ordinance in every work place or other location in which employees or other persons contracting for employment are working.
- (b) To provide to the City payroll records or other documentation within ten (10) business days from the receipt of a request by the City.
- (c) To permit access to work sites to City representatives for the purposes of monitoring compliance, and investigating complaints or non-compliance.
- (d) To take no action that would reduce the compensation, wages, fringe benefits, or leave available to any employee covered by the Living Wage Ordinance or any person contracted for employment and covered by the Living Wage Ordinance in order to pay the living wage required by the Living Wage Ordinance.

The undersigned states that he/she has the requisite authority to act on behalf of his/her employer in these matters and has offered to provide the services or agrees to accept financial assistance in accordance with the terms of the Living Wage Ordinance. The undersigned certifies that he/she has read and is familiar with the terms of the Living Wage Ordinance, obligates the Employer/Grantee to those terms and acknowledges that if his/her employer is found to be in violation of Ordinance it may be subject to civil penalties and termination of the awarded contract or grant of financial assistance.

 Company Name

 Street Address

 Signature of Authorized Representative

 Date

 City, State, Zip

 Print Name and Title

 Phone/Email address

CITY OF ANN ARBOR LIVING WAGE ORDINANCE

RATE EFFECTIVE APRIL 30, 2018 - ENDING APRIL 29, 2019

\$13.22 per hour

If the employer provides health care benefits*

\$14.75 per hour

If the employer does **NOT** provide health care benefits*

Employers providing services to or for the City of Ann Arbor or recipients of grants or financial assistance from the City of Ann Arbor for a value of more than \$10,000 in a twelve-month period of time must pay those employees performing work on a City of Ann Arbor contract or grant, the above living wage.

ENFORCEMENT

The City of Ann Arbor may recover back wages either administratively or through court action for the employees that have been underpaid in violation of the law. Persons denied payment of the living wage have the right to bring a civil action for damages in addition to any action taken by the City.

Violation of this Ordinance is punishable by fines of not more than \$500/violation plus costs, with each day being considered a separate violation. Additionally, the City of Ann Arbor has the right to modify, terminate, cancel or suspend a contract in the event of a violation of the Ordinance.

* Health Care benefits include those paid for by the employer or making an employer contribution toward the purchase of health care. The employee contribution must not exceed \$.50 an hour for an average work week; and the employer cost or contribution must equal no less than \$1/hr for the average work week.

The Law Requires Employers to Display This Poster Where Employees Can Readily See It.

**For Additional Information or to File a Complaint Contact:
Colin Spencer at 734/794-6500 or cspencer@a2gov.org**



Vendor Conflict of Interest Disclosure Form
--

All vendors interested in conducting business with the City of Ann Arbor must complete and return the Vendor Conflict of Interest Disclosure Form in order to be eligible to be awarded a contract. Please note that all vendors are subject to comply with the City of Ann Arbor’s conflict of interest policies as stated within the certification section below.

If a vendor has a relationship with a City of Ann Arbor official or employee, an immediate family member of a City of Ann Arbor official or employee, the vendor shall disclose the information required below.

1. No City official or employee or City employee’s immediate family member has an ownership interest in vendor’s company or is deriving personal financial gain from this contract.
2. No retired or separated City official or employee who has been retired or separated from the City for less than one (1) year has an ownership interest in vendor’s Company.
3. No City employee is contemporaneously employed or prospectively to be employed with the vendor.
4. Vendor hereby declares it has not and will not provide gifts or hospitality of any dollar value or any other gratuities to any City employee or elected official to obtain or maintain a contract.
5. Please note any exceptions below:

Conflict of Interest Disclosure*	
Name of City of Ann Arbor employees, elected officials or immediate family members with whom there may be a potential conflict of interest.	<input type="checkbox"/> Relationship to employee <hr style="border: 0; border-top: 1px solid black;"/> <input type="checkbox"/> Interest in vendor’s company <input type="checkbox"/> Other (please describe in box below)

*Disclosing a potential conflict of interest does not disqualify vendors. In the event vendors do not disclose potential conflicts of interest and they are detected by the City, vendor will be exempt from doing business with the City.

I certify that this Conflict of Interest Disclosure has been examined by me and that its contents are true and correct to my knowledge and belief and I have the authority to so certify on behalf of the Vendor by my signature below:		
Vendor Name	Vendor Phone Number	
Signature of Vendor Authorized Representative	Date	Printed Name of Vendor Authorized Representative

Questions about this form? Contact Procurement Office City of Ann Arbor Phone: 734/794-6500, procurement@a2gov.org

CITY OF ANN ARBOR NON-DISCRIMINATION ORDINANCE

Relevant provisions of Chapter 112, Nondiscrimination, of the Ann Arbor City Code are included below.
You can review the entire ordinance at www.a2gov.org/humanrights.

Intent: It is the intent of the city that no individual be denied equal protection of the laws; nor shall any individual be denied the enjoyment of his or her civil or political rights or be discriminated against because of actual or perceived age, arrest record, color, disability, educational association, familial status, family responsibilities, gender expression, gender identity, genetic information, height, HIV status, marital status, national origin, political beliefs, race, religion, sex, sexual orientation, source of income, veteran status, victim of domestic violence or stalking, or weight.

Discriminatory Employment Practices: No person shall discriminate in the hire, employment, compensation, work classifications, conditions or terms, promotion or demotion, or termination of employment of any individual. No person shall discriminate in limiting membership, conditions of membership or termination of membership in any labor union or apprenticeship program.

Discriminatory Effects: No person shall adopt, enforce or employ any policy or requirement which has the effect of creating unequal opportunities according to actual or perceived age, arrest record, color, disability, educational association, familial status, family responsibilities, gender expression, gender identity, genetic information, height, HIV status, marital status, national origin, political beliefs, race, religion, sex, sexual orientation, source of income, veteran status, victim of domestic violence or stalking, or weight for an individual to obtain housing, employment or public accommodation, except for a bona fide business necessity. Such a necessity does not arise due to a mere inconvenience or because of suspected objection to such a person by neighbors, customers or other persons.

Nondiscrimination by City Contractors: All contractors proposing to do business with the City of Ann Arbor shall satisfy the contract compliance administrative policy adopted by the City Administrator in accordance with the guidelines of this section. All city contractors shall ensure that applicants are employed and that employees are treated during employment in a manner which provides equal employment opportunity and tends to eliminate inequality based upon any classification protected by this chapter. All contractors shall agree not to discriminate against an employee or applicant for employment with respect to hire, tenure, terms, conditions, or privileges of employment, or a matter directly or indirectly related to employment, because of any applicable protected classification. All contractors shall be required to post a copy of Ann Arbor's Non-Discrimination Ordinance at all work locations where its employees provide services under a contract with the city.

Complaint Procedure: If any individual believes there has been a violation of this chapter, he/she may file a complaint with the City's Human Rights Commission. The complaint must be filed within 180 calendar days from the date of the individual's knowledge of the allegedly discriminatory action or 180 calendar days from the date when the individual should have known of the allegedly discriminatory action. A complaint that is not filed within this timeframe cannot be considered by the Human Rights Commission. To file a complaint, first complete the complaint form, which is available at www.a2gov.org/humanrights. Then submit it to the Human Rights Commission by e-mail (hrc@a2gov.org), by mail (Ann Arbor Human Rights Commission, PO Box 8647, Ann Arbor, MI 48107), or in person (City Clerk's Office). For further information, please call the commission at 734-794-6141 or e-mail the commission at hrc@a2gov.org.

Private Actions For Damages or Injunctive Relief: To the extent allowed by law, an individual who is the victim of discriminatory action in violation of this chapter may bring a civil action for appropriate injunctive relief or damages or both against the person(s) who acted in violation of this chapter.

THIS IS AN OFFICIAL GOVERNMENT NOTICE AND
MUST BE DISPLAYED WHERE EMPLOYEES CAN READILY SEE IT.

MICHIGAN DEPARTMENT OF TRANSPORTATION CERTIFIED PAYROLL

COMPLETION OF CERTIFIED PAYROLL FORM FULFILLS THE MINIMUM MDOT PREVAILING WAGE REQUIREMENTS

(1) NAME OF CONTRACTOR / SUBCONTRACTOR (CIRCLE ONE) (2) ADDRESS

(3) PAYROLL NO. (4) FOR WEEK ENDING (5) PROJECT AND LOCATION (6) CONTRACT ID

(a) EMPLOYEE INFORMATION	(b) WORK CLASSIFICATION	(c) Hour Type	(d) DAY AND DATE							(e) TOTAL HOURS ON PROJECT	(f) PROJECT RATE OF PAY	(g) PROJECT RATE OF FRINGE PAY	(h) GROSS PROJECT EARNED		(i) TOTAL WEEKLY HOURS WORKED ALL JOBS	(j) DEDUCTIONS						(k) TOTAL WEEKLY WAGES PAID FOR ALL JOBS
														GROSS PROJECT EARNED		GROSS WEEKLY EARNED	FICA	FEDERAL	STATE	OTHER	TOTAL DEDUCT	
NAME:									0			\$0.00	/								\$0.00	\$0.00
ETH#GEN: ID #:	GROUP/CLASS #:	S							0			\$0.00	/								\$0.00	\$0.00
NAME:									0			\$0.00	/								\$0.00	\$0.00
ETH#GEN: ID #:	GROUP/CLASS #:	S							0			\$0.00	/								\$0.00	\$0.00
NAME:									0			\$0.00	/								\$0.00	\$0.00
ETH#GEN: ID #:	GROUP/CLASS #:	S							0			\$0.00	/								\$0.00	\$0.00
NAME:									0			\$0.00	/								\$0.00	\$0.00
ETH#GEN: ID #:	GROUP/CLASS #:	S							0			\$0.00	/								\$0.00	\$0.00
NAME:									0			\$0.00	/								\$0.00	\$0.00
ETH#GEN: ID #:	GROUP/CLASS #:	S							0			\$0.00	/								\$0.00	\$0.00
NAME:									0			\$0.00	/								\$0.00	\$0.00
ETH#GEN: ID #:	GROUP/CLASS #:	S							0			\$0.00	/								\$0.00	\$0.00
NAME:									0			\$0.00	/								\$0.00	\$0.00

Date _____

I, _____ (Name of Signatory Party) _____ (Title)

do hereby state:

(1) That I pay or supervise the payment of the persons employed by

_____ on the _____ (Contractor or Subcontractor)
 _____; that during the payroll period commencing on the _____ (Building or Work)
 _____ day of _____, _____, and ending the _____ day of _____, _____,
 all persons employed on said project have been paid the full weekly wages earned, that no rebates have been or will be made either directly or indirectly to or on behalf of said

_____ from the full _____ (Contractor or Subcontractor)

weekly wages earned by any person and that no deductions have been made either directly or indirectly from the full wages earned by any person, other than permissible deductions as defined in Regulations, Part 3 (29 C.F.R. Subtitle A), issued by the Secretary of Labor under the Copeland Act, as amended (48 Stat. 948, 63 Stat. 108, 72 Stat. 967; 76 Stat. 357; 40 U.S.C. § 3145), and described below:

(2) That any payrolls otherwise under this contract required to be submitted for the above period are correct and complete; that the wage rates for laborers or mechanics contained therein are not less than the applicable wage rates contained in any wage determination incorporated into the contract; that the classifications set forth therein for each laborer or mechanic conform with the work he performed.

(3) That any apprentices employed in the above period are duly registered in a bona fide apprenticeship program registered with a State apprenticeship agency recognized by the Bureau of Apprenticeship and Training, United States Department of Labor, or if no such recognized agency exists in a State, are registered with the Bureau of Apprenticeship and Training, United States Department of Labor.

(4) That:

(a) WHERE FRINGE BENEFITS ARE PAID TO APPROVED PLANS, FUNDS, OR PROGRAMS

- in addition to the basic hourly wage rates paid to each laborer or mechanic listed in the above referenced payroll, payments of fringe benefits as listed in the contract have been or will be made to appropriate programs for the benefit of such employees, except as noted in section 4(c) below.

(b) WHERE FRINGE BENEFITS ARE PAID IN CASH

- Each laborer or mechanic listed in the above referenced payroll has been paid, as indicated on the payroll, an amount not less than the sum of the applicable basic hourly wage rate plus the amount of the required fringe benefits as listed in the contract, except as noted in section 4(c) below.

(c) EXCEPTIONS

EXCEPTION (CRAFT)	EXPLANATION
REMARKS:	
NAME AND TITLE	SIGNATURE
THE WILLFUL FALSIFICATION OF ANY OF THE ABOVE STATEMENTS MAY SUBJECT THE CONTRACTOR OR SUBCONTRACTOR TO CIVIL OR CRIMINAL PROSECUTION. SEE SECTION 1001 OF TITLE 18 AND SECTION 231 OF TITLE 31 OF THE UNITED STATES CODE.	