

# ADDENDUM No. 1

ITB No. 4557

## 2019 Streetlight Replacement

**Due: December 20, 2018 at 10:00 A.M. (local time)**

The following changes, additions, and/or deletions shall be made to the Invitation to Bid for the 2019 Streetlight Replacement project, ITB No. 4557, on which bids will be received on/or before the date and time listed above.

The information contained herein shall take precedence over the original documents and all previous addenda (if any), and is appended thereto. **This Addendum includes nineteen (19) pages.**

**The Bidder is to acknowledge receipt of this Addendum No. 1, including all attachments in its Bid by so indicating on page ITB-1 of the Invitation to Bid Form. Bids submitted without acknowledgement of receipt of this addendum may be considered non-conforming.**

The following forms provided within the ITB Document must be included in submitted proposal:

- City of Ann Arbor Non-Discrimination Declaration of Compliance
- City of Ann Arbor Living Wage Declaration of Compliance
- Vendor Conflict of Interest Disclosure Form
- City of Ann Arbor Prevailing Wage Declaration of Compliance

**Bids that fail to provide these completed forms listed above upon bid opening will be rejected as non-responsive and will not be considered for award.**

### I. CLARIFICATIONS

1. For light poles with banner arms located within the City's amenity zone, banner arms shall be oriented toward sidewalk. For light poles with banner arms not located within the City's amenity zone, banner arms shall be oriented toward the road and the center of the light pole foundation must be 3 feet from the back of curb. The light pole foundation may need to be shifted in non-amenity zone locations to accommodate the 3 foot offset requirement from back of curb. In general, there is an amenity zone along Liberty Street, but no amenity zone along Fourth Avenue.
2. Plan Sheets 13-24 are revised so that legend numbered callouts are not greyed out. These sheets have been included to show numbered callouts.
3. Pre-Bid Meeting notes and sign-in sheet are attached to this Addendum.

### II. QUESTIONS AND ANSWERS

The following Questions have been received by the City. Responses are being provided in accordance with the terms of the ITB. Respondents are directed to take note in its review of the documents of the following questions and City responses as they affect work or details in other areas not specifically referenced here.

Question 1: What entity is responsible for providing light poles, fixtures, and luminaires?

Answer 1: The Contractor is responsible for providing and installing all materials for this project, including light poles, fixtures, and luminaires unless otherwise specified in the contract documents.

Plan Sheet 6 has been updated to reflect revision. Revision is clouded on sheet.

Bidders are responsible for any conclusions that they may draw from the information contained in the Addendum.

**PREBID MEETING SIGN-IN SHEET**

**PROJECT:**

**2019 Streetlight Replacement**

**ITB 4557**

**Date: 12/6/18**

PLEASE PRINT

NAME	REPRESENTING	MAILING ADDRESS	TELEPHONE	EMAIL
Chris Elenbaas Public Works Engineer	City of Ann Arbor - Public Works	Address: <u>4251 Stone School Road</u> City, State: <u>Ann Arbor, MI</u> Zip: <u>48107-8647</u>	Office: (734) 794-6350 x43311 Mobile: (734) 358-2029 Fax: (734) 994-0742	<a href="mailto:celenbaas@a2gov.org">celenbaas@a2gov.org</a>
Brad Davis	Ravornu	Address: <u>14140 33 mile rd</u> City, State: <u>Buce Twp MI</u> Zip: <u>48065</u>	Office: ( ) Mobile: (586) <u>747-3131</u> Fax No. ( )	<a href="mailto:bdavis@ravornuenergy.com">bdavis@ravornuenergy.com</a>
Gage Agin	J. Ranck Electric	Address: <u>1993 Gover Pkwy.</u> City, State: <u>Mt Pleasant, MI</u> Zip: <u>48856</u>	Office: (989) <u>775-7393</u> Mobile: ( ) Fax No. (989) <u>775-4630</u>	<a href="mailto:gagin@jranck.com">gagin@jranck.com</a>
Justin Serpotti	Corby Energy	Address: <u>6001 Schooner Dr.</u> City, State: <u>Bellevue, MI</u> Zip: <u>48111</u>	Office: ( ) Mobile: (313) <u>350-2420</u> Fax No. ( )	<a href="mailto:JSERPOTTI@CORBYENERGY.COM">JSERPOTTI@CORBYENERGY.COM</a>
KAREN BEHRENDT	STATELINE	Address: <u>1135 BEAUFAIT</u> City, State: <u>DETROIT MI</u> Zip: <u>48202</u>	Office: (586) <u>904.8010</u> Mobile: ( ) Fax No. ( )	<a href="mailto:KAREN@STATELINEUSA.COM">KAREN@STATELINEUSA.COM</a>
Mark McVicar	Corby Energy	Address: <u>6001 Schooner Dr</u> City, State: <u>Bellevue</u> Zip: <u>48111</u>	Office: (234) <u>595 923</u> Mobile: (33) <u>502 111</u> Fax No. ( )	<a href="mailto:MMVICAR@CORBYENERGY.COM">MMVICAR@CORBYENERGY.COM</a>
		Address: _____ City, State: _____ Zip: _____	Office: ( ) Mobile: ( ) Fax No. ( )	
		Address: _____ City, State: _____ Zip: _____	Office: ( ) Mobile: ( ) Fax No. ( )	



# **2019 STREETLIGHT REPLACEMENT**

Pre-Bid Meeting Agenda ITB 4557

December 6, 2018 at 2:30 PM

The Wheeler Service Center

- I. Introductions
- II. Addendum Items
  - a. Addenda – None to date
    - i. Pre-Bid minutes, including sign in sheet.
    - ii. Minor Revisions may be issued in an addenda by next week, if needed.
- III. General
  - a. Project Overview
    - i. Replacement of 73 light poles and 52 foundations.
    - ii. Additional work includes replaced and reinstalled luminaires, a replaced handhole, replacement of conductors as needed and restoration of impact areas.
    - iii. Record of existing conditions by visual tape recording is required.
  - b. Bid Opening
    - i. December 20, 10:00 AM EST – Refer to invitation to bid for information.
    - ii. **The bids will be opened and read aloud publicly. All bid material must be delivered to City Hall prior to bid opening to be considered.**
  - c. Bid Submission Requirements
    - i. Refer to invitation to bid for full list of bid submittal requirements.
  - d. Standard Specifications and Detailed Specifications
    - i. Project Schedule
      - Starting Date – Estimated start of March 1<sup>st</sup>
      - Completion Date – June 23<sup>rd</sup> (or 115 days after notice to proceed).
      - Hours of work: 7:00 AM to 8:00 PM Monday thru Friday (Saturday's **and Sunday's** with written permission).
    - ii. Engineer's estimate – No Engineer's Estimate Provided.
    - iii. Access to light poles – Unless otherwise authorized, Contractor shall confine work activities to road ROW. Contractor shall submit **one** ROW **permit** and lane closure permits for each individual lane closure; contractor shall submit lane closure permit 48 hours prior to lane closure **via Ann Arbor's online system**. City will waive ROW and lane closure permit fees. When applicable to work zone, Contractor shall coordinate daily with DDA and Republic Parking Systems to bag parking meters, and use car parking and bicycle spaces for construction staging. Contractor is responsible for maintaining access to driveways during construction, and notifying businesses when access will be unavailable.
    - iv. De-energize streetlights – Contractor shall coordinate with City of Ann Arbor **crews to isolate and turn off streetlights; isolation of circuits downtown may require more time than outside of downtown.**
    - v. Pedestrian access must be maintained unless otherwise noted. Contractor shall utilize Pedestrian Type II Barricades when necessary, as described in Appendix

C. Barricades must be ADA compliant, and sidewalk access must be maintained throughout the project.

- e. Special Provisions & Details
  - i. Refer to invitation to bid appendices A-C for special provisions and details.

#### IV. Construction

- a. Streetlight Replacement
  - i. Fifty-two foundations proposed to be removed and replaced
  - ii. Seventy-three light poles to be removed and replaced
  - iii. At least one light pole will be removed, salvaged and reinstalled
  - iv. At least one street lighting handhole will be removed and replaced
  - v. All impact areas shall be restored as existing; materials include sidewalk, brick pavers and topsoil, among others
  - vi. Thirty-five fixtures to be removed and replaced
  - vii. Thirty-eight fixtures to be removed, salvaged and reinstalled
- b. Maintenance of Traffic – Contractor shall ensure work activities and potential risks are protected from pedestrian access.
- c. Maintenance of Lighting – On a **single** city block, only **half-of** the light fixtures **on one side of the street** may be impacted at a time. Coordinate streetlight de-energizing with City of Ann Arbor.

#### V. Other Items

- a. Scope is subject to change to reflect allocated project budget.
- b. **State Street work may be require coordination with ongoing DTE utility work.**
- c. **Lead time on downtown fixtures may push back construction dates. The Contractor shall relay lead time information from fixture/pole suppliers to the City.**

#### Contact Information:

Kyle Selter  
Project Engineer  
Phone: (734) 466-4562  
E-mail: [Kyle.Selter@ohm-advisors.com](mailto:Kyle.Selter@ohm-advisors.com)

**\*Added comments from pre-bid meeting discussion**

### LIGHT FIXTURE SCHEDULE

TYPE	DESCRIPTION	MANUFACTURER	CATALOG #	LAMPS	REMARKS
SL1	DECORATIVE GLOBE STREET LIGHT	LUMECON	L35W- -1-NW-B-D	LED	ORIENT BANNER ARMS AS DIRECTED BY ENGINEER. ORIENT RECEPTACLE AND POLE HANDHOLE AWAY FROM ROAD. LUMINARIES ARE FURNISHED AND INSTALLED BY CONTRACTOR. POLES WITH BANNER ARMS, POLE HANDHOLES AND RECEPTACLES ARE CONTRACTOR FURNISHED AND INSTALLED. FIXTURE TO BE MOUNTED ON POLE TYPE LP1.
SL2	DUAL FIXTURE DECORATIVE GLOBE STREET LIGHT	LUMECON	L35W- -1-NW-B-D	LED	
SL3	COBRA HEAD STREET LIGHT	LEOTEK	GCM2 40H MV NW 3R BK 850 FFA PCR7-CR	LED	ORIENT BANNER ARMS AS DIRECTED BY ENGINEER. ORIENT RECEPTACLE AND POLE HANDHOLE AWAY FROM ROAD. ORIENT LUMINAIRES PARALLEL TO THE ROAD. LUMINAIRES ARE FURNISHED AND INSTALLED BY CONTRACTOR. POLES WITH BANNER ARMS, POLE HANDHOLES AND RECEPTACLES ARE CONTRACTOR FURNISHED AND INSTALLED. FIXTURE TO BE MOUNTED ON POLE TYPE LP2.
					FIXTURE TO BE MOUNTED ON POLE TYPE LP3.

### GENERAL NOTES

- PROVIDE QUAZITE MODEL PC1118BA12 WITH COVER PC1118HA00 OR APPROVED EQUIVALENT.
- BOX AND COVER SHALL BE POLYMER CONCRETE.
- COVERS SHALL BE SECURED WITH 3/8" BOLTS, NUTS, AND WASHERS, WHICH SHALL BE BRASS, STAINLESS STEEL OR OTHER CORROSION RESISTANT MATERIAL. STAINLESS STEEL SHALL HAVE A CHROMIUM CONTENT OF NOT LESS THAN 18% AND A NICKEL CONTENT OF NOT LESS THAN 8%, NUTS SHALL BE RECESSED BELOW TOP SURFACE OF COVER.
- COVER LETTERING SHALL BE 1/2" MINIMUM LETTERS CAST IN STANDARD MARKINGS: (STREET LIGHTING).
- CONDUIT ENTERING THE BOX SHALL HAVE 90° LONG RADIUS BEND (INSIDE THE BOX). THE CONDUITS OPENING, INSIDE THE BOX, SHALL BE AT LEAST 4" BELOW THE LID, OPENING SHALL HAVE SMOOTH EDGE. IF THE CONDUIT IS P.V.C. A SLIP COUPLING MUST BE USED. IF THE CONDUIT IS RIGID PIPE, A PROTECTIVE BUSHING SHALL BE USED.
- CONDUCTORS SHALL HAVE A MINIMUM OF 24" SLACK FROM CONDUIT BELL END.
- BACKFILL WITH EXCAVATED MATERIAL AND THOROUGHLY COMPACT.
- WHERE HANDHOLES ARE INSTALLED IN CONCRETE AREAS, 1/2" PREMOLDED EXPANSION JOINT SHALL BE INSTALLED AROUND THE BOX.
- BOXES IN NON-VEHICLE TRAFFIC AREAS TO BE TIER 8 AND IN VEHICLE TRAFFIC AREAS TO BE TIER 22 UNLESS OTHERWISE NOTED.

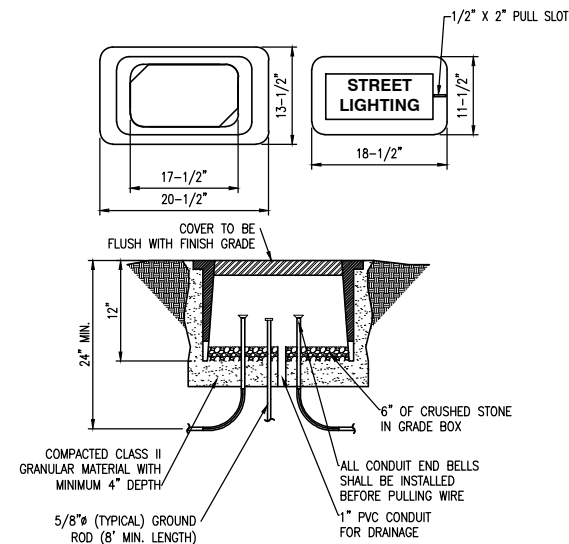

HANDHOLE DETAIL

NOT TO SCALE

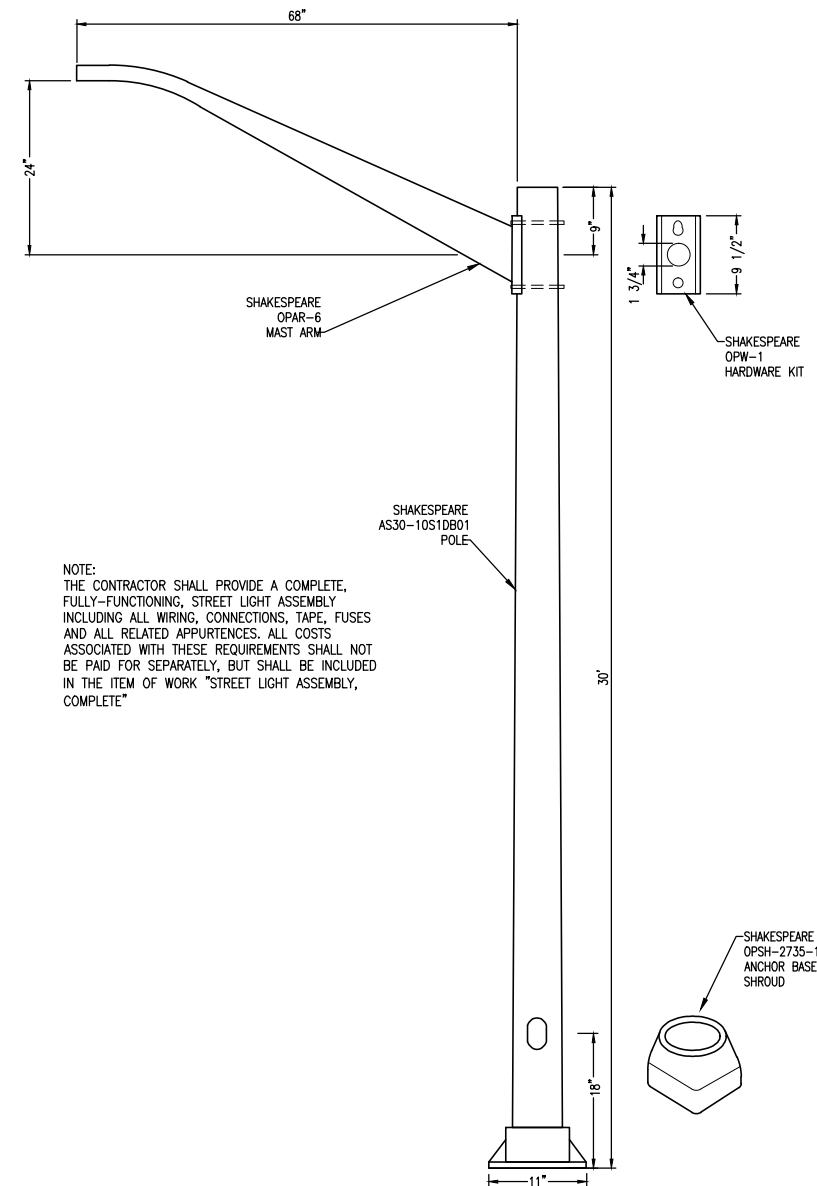

POLE TYPE LP3 DETAIL

NOT TO SCALE

NOTE:  
THE CONTRACTOR SHALL PROVIDE A COMPLETE, FULLY-FUNCTIONING, STREET LIGHT ASSEMBLY INCLUDING ALL WIRING, CONNECTIONS, TAPE, FUSES AND ALL RELATED APPURTENANCES. ALL COSTS ASSOCIATED WITH THESE REQUIREMENTS SHALL NOT BE PAID FOR SEPARATELY, BUT SHALL BE INCLUDED IN THE ITEM OF WORK "STREET LIGHT ASSEMBLY, COMPLETE"

REVISIONS:  
11-28-18 BID SET  
12-14-18 ADDENDUM No. 1 REVISIONS

CITY OF ANN ARBOR  
ITB NO. 4557 2019 STREET LIGHT REPLACEMENT  
ELECTRICAL DETAILS, LIGHT FIXTURE SCHEDULE

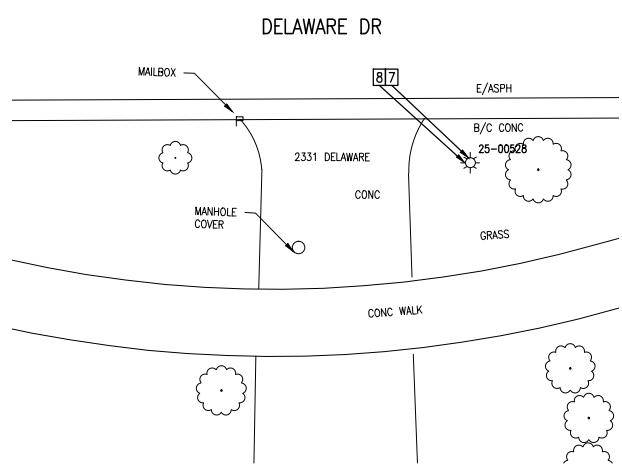

#1 - 2331 DELAWARE DR  
EAST OF TILSBY CT

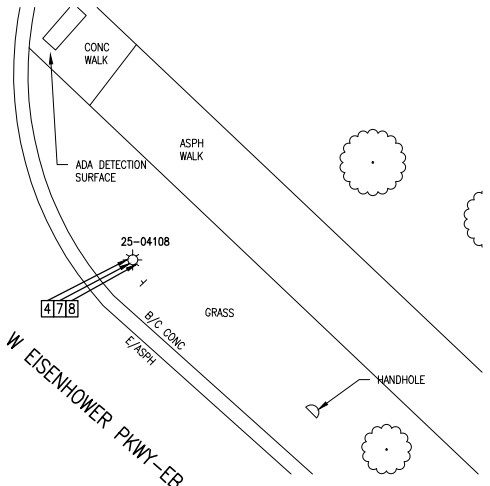

#2 - W EISENHOWER PKWY-EB  
AT CRANBROOK VILLAGE ENTRANCE

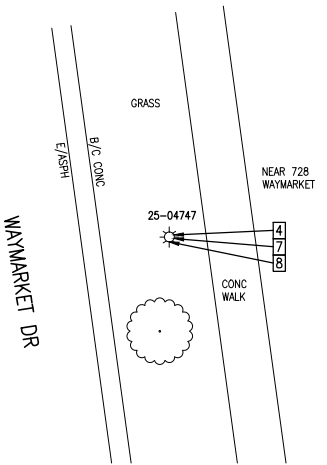

#3 - WAYMARKET DR NEAR  
BRIAR COVE TERR. APPTS

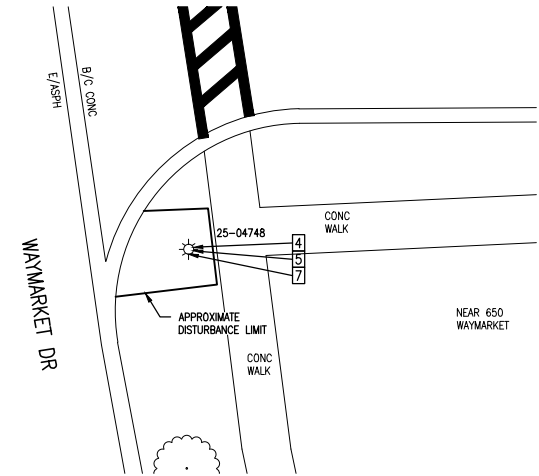

#4 - WAYMARKET DR NEAR  
BRIAR COVE TERR. APPTS

NOTE: POLE LOCATION 25-00528 HAS  
LOOSE WIRING. TO BE ADDRESSED  
DURING CONSTRUCTION

**REMOVAL KEY**

- 1 CONCRETE WALK, REMOVE
- 2 BRICK PAVER WALK, REMOVE & SALVAGE
- 3 PAVEMENT, REMOVE
- 4 LIGHT POLE, REMOVE
- 5 FOUNDATION, REMOVE
- 6 FIXTURE, REMOVE
- 7 FIXTURE, REMOVE & SALVAGE
- 8 FOUNDATION, PROTECT
- 9 HANDHOLE, REMOVE
- 10 LIGHT POLE, REMOVE & SALVAGE
- 11 LIGHT POLE, PROTECT

**REMOVAL PLAN**

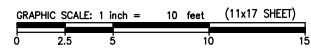

**QUANTITIES THIS SHEET**

TOTAL	UNIT	DESCRIPTION
1	Ea	Foundation, Rem
3	Ea	Light Pole, Rem
1	Ea	Foundation, Light Pole
3	Ea	Light Pole, LP3
4	Ea	Fixture, Reinstall

**CONSTRUCTION KEY**

- 1 CONCRETE WALK
- 2 BRICK PAVER WALK, REINSTALL
- 3 ADA RAMP
- 4 CONCRETE PAVEMENT
- 5 HMA PAVEMENT
- 6 TOPSOIL, SEED & MULCH
- 7 POLE FOUNDATION
- 8 LIGHT POLE, LP1
- 9 LIGHT POLE, LP2
- 10 LIGHT POLE, LP3
- 11 FIXTURE, REINSTALL
- 12 FIXTURE, SL1
- 13 FIXTURE, SL2
- 14 FIXTURE, SL3
- 15 HANDHOLE
- 16 LIGHT POLE, REINSTALL

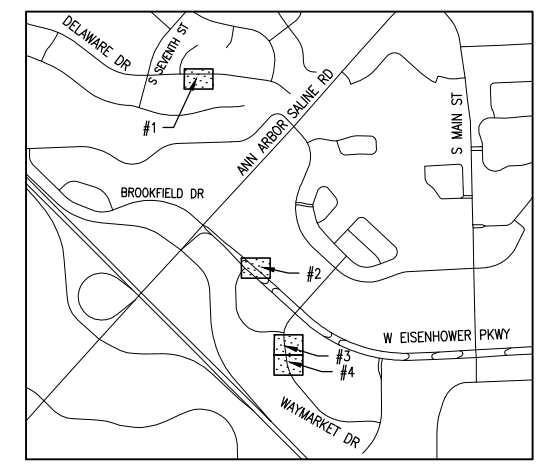

**KEY PLAN**  
NOT TO SCALE

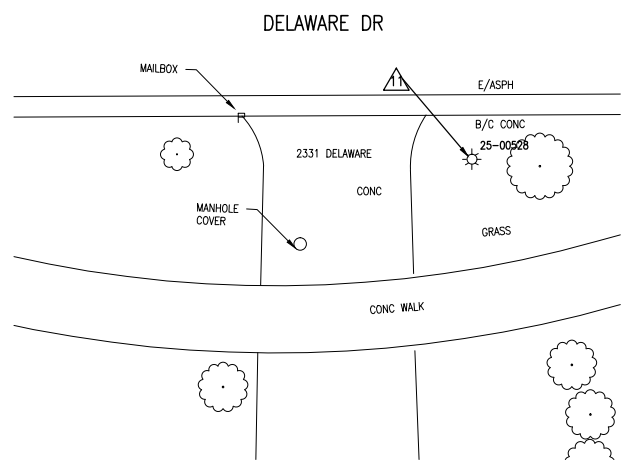

#1 - 2331 DELAWARE DR  
EAST OF TILSBY CT

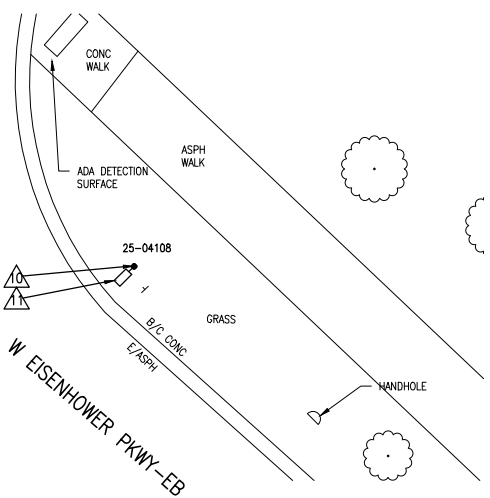

#2 - W EISENHOWER PKWY-EB  
AT CRANBROOK VILLAGE ENTRANCE

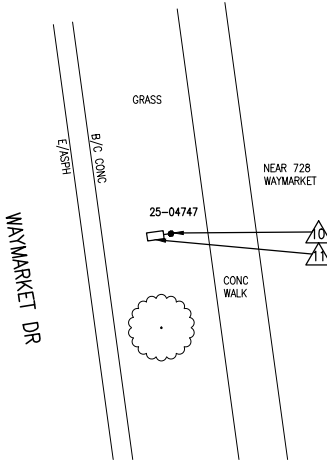

#3 - WAYMARKET DR NEAR  
BRIAR COVE TERR. APPTS

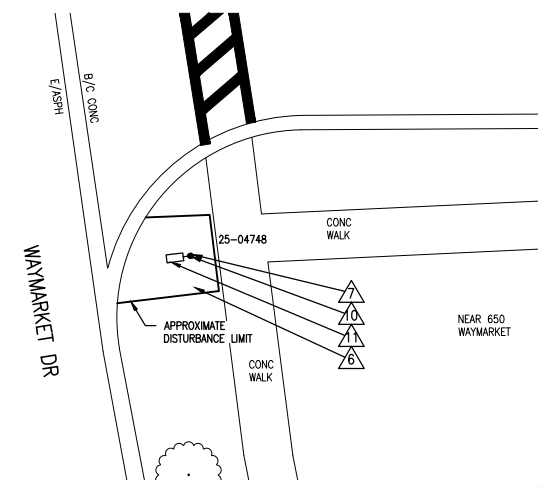

#4 - WAYMARKET DR NEAR  
BRIAR COVE TERR. APPTS

**CONSTRUCTION PLAN**

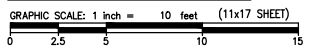

REVISIONS:  
 11-28-18 BID SET  
 12-14-18 ADDENDUM No. 1 REVISIONS

CITY OF ANN ARBOR  
 ITB NO. 4557 2019 STREET LIGHT REPLACEMENT  
 REMOVAL & CONSTRUCTION PLAN



Know what's below.  
Call before you dig.

DRAWING PATH: P:\0000\_01000028180040\_44\_Street\_LL\Replaces\_FY\_19\_CIP\Drawings\Civil\Plans\_Consist\80040CON\_01.dwg Date: 12/13/2018 9:43:38m

COPYRIGHT 2017 OHM ALL DRAWINGS AND WRITTEN MATERIALS APPEARING HEREIN CONSTITUTE THE ORIGINAL AND UNPUBLISHED WORK OF OHM AND THE SAME MAY NOT BE DUPLICATED, DISTRIBUTED, OR DISCLOSED WITHOUT PRIOR WRITTEN CONSENT OF OHM



DRAWING PATH: P:\0000\_01000028180040\_44\_Street\_LL\Revised\_EY\_19\_CIP\Drawings\Civil\Plans\_Consist\80040CON\_01.dwg Date: 12/13/2018 9:43:30m

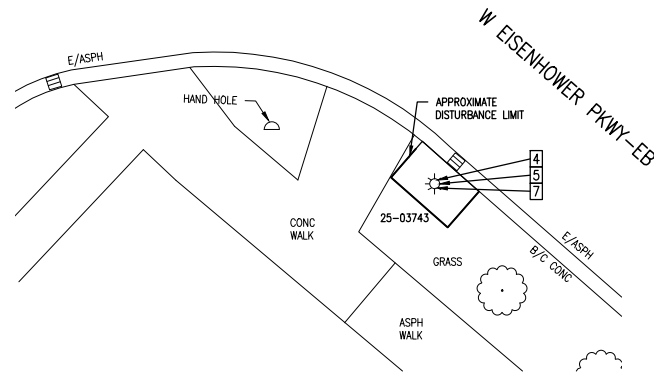

#1 - W EISENHOWER PKWY-EB AT WAYMARKET DR

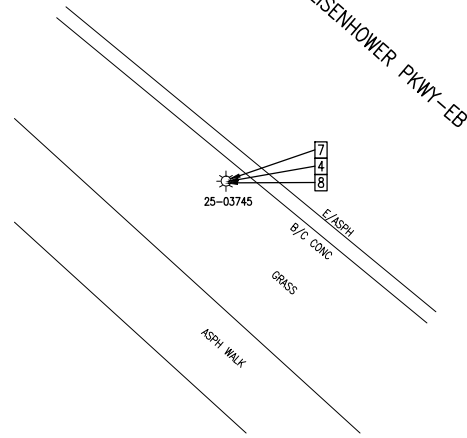

#2 - W EISENHOWER PKWY-EB EAST OF WAYMARKET DR

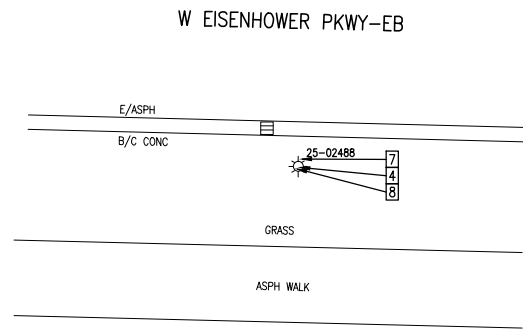

#3 - W EISENHOWER PKWY-EB AT MICHIGAN LEFT EAST OF SIGNATURE BLVD

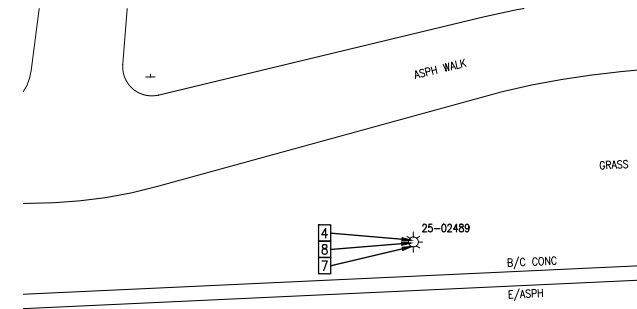

#4 - W EISENHOWER PKWY-WB AT MICHIGAN LEFT EAST OF SIGNATURE BLVD

**REMOVAL KEY**

- 1 CONCRETE WALK, REMOVE
- 2 BRICK PAVER WALK, REMOVE & SALVAGE
- 3 PAVEMENT, REMOVE
- 4 LIGHT POLE, REMOVE
- 5 FOUNDATION, REMOVE
- 6 FIXTURE, REMOVE
- 7 FIXTURE, REMOVE & SALVAGE
- 8 FOUNDATION, PROTECT
- 9 HANDHOLE, REMOVE
- 10 LIGHT POLE, REMOVE & SALVAGE
- 11 LIGHT POLE, PROTECT

**REMOVAL PLAN**

GRAPHIC SCALE: 1 inch = 10 feet (11x17 SHEET)

**QUANTITIES THIS SHEET**

TOTAL	UNIT	DESCRIPTION
1	Ea	Foundation, Rem
4	Ea	Light Pole, Rem
1	Ea	Foundation, Light Pole
4	Ea	Light Pole, LP3
4	Ea	Fixture, Reinstall

**CONSTRUCTION KEY**

- 1 CONCRETE WALK
- 2 BRICK PAVER WALK, REINSTALL
- 3 ADA RAMP
- 4 CONCRETE PAVEMENT
- 5 HMA PAVEMENT
- 6 TOPSOIL, SEED & MULCH
- 7 POLE FOUNDATION
- 8 LIGHT POLE, LP1
- 9 LIGHT POLE, LP2
- 10 LIGHT POLE, LP3
- 11 FIXTURE, REINSTALL
- 12 FIXTURE, SL1
- 13 FIXTURE, SL2
- 14 FIXTURE, SL3
- 15 HANDHOLE
- 16 LIGHT POLE, REINSTALL

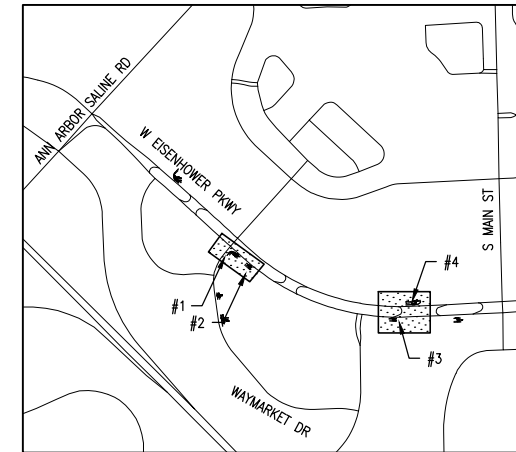

**KEY PLAN**  
NOT TO SCALE

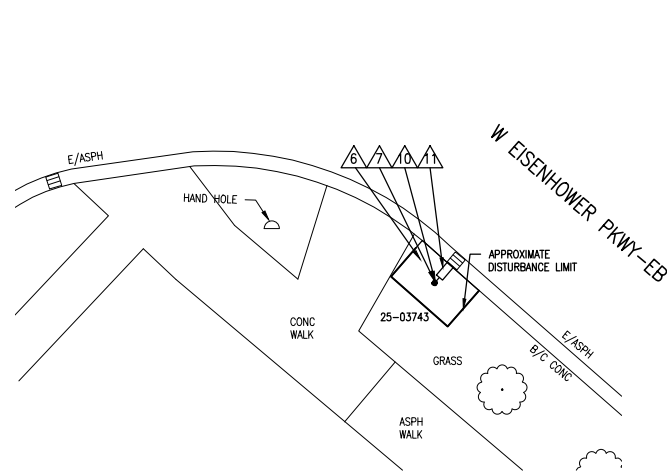

#1 - W EISENHOWER PKWY-EB AT WAYMARKET DR

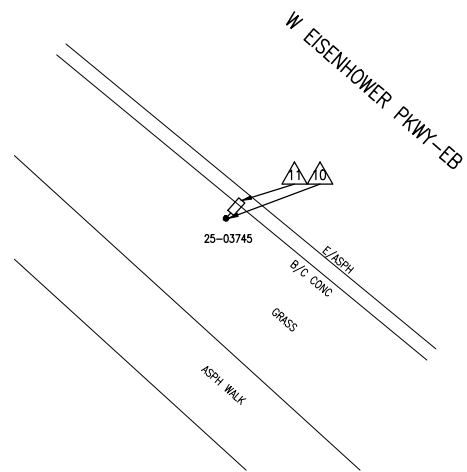

#2 - W EISENHOWER PKWY-EB EAST OF WAYMARKET DR

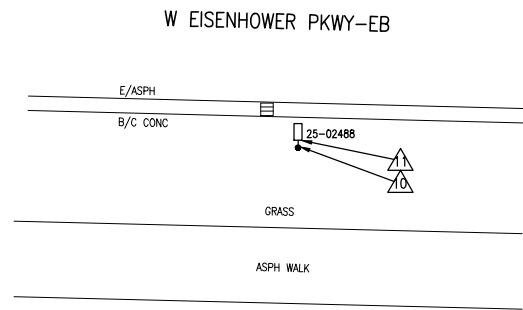

#3 - W EISENHOWER PKWY-EB AT MICHIGAN LEFT EAST OF SIGNATURE BLVD

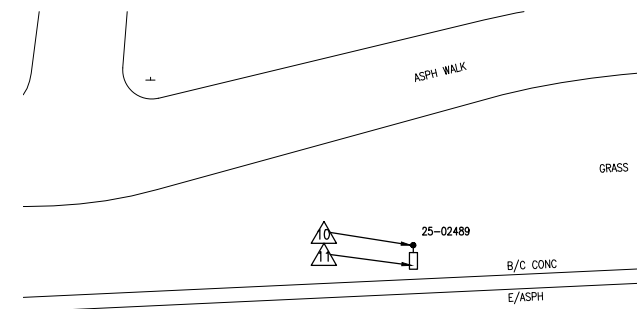

#4 - W EISENHOWER PKWY-WB AT MICHIGAN LEFT EAST OF SIGNATURE BLVD

**CONSTRUCTION PLAN**

GRAPHIC SCALE: 1 inch = 10 feet (11x17 SHEET)



REVISIONS:  
11-28-18 BID SET  
12-14-18 ADDENDUM No. 1 REVISIONS

DATE: 12/13/2018  
PROJECT: 0028-R-2019  
PROJ. NO.: 0028-R-2019  
PROJ. NAME: WASHINGTON  
CITY/TOWNSHIP: ANN ARBOR  
COUNTY: WASHTENAW  
SCALE: AS NOTED  
VERT. DATUM: NAVD83  
HORIZ. DATUM: NAD83

**CITY OF ANN ARBOR**  
ITB NO. 4557 2019 STREET LIGHT REPLACEMENT  
REMOVAL & CONSTRUCTION PLAN



Know what's below.  
Call before you dig.

COPYRIGHT 2017 OHM ALL DRAWINGS AND WRITTEN MATERIALS APPEARING HEREIN CONSTITUTE THE ORIGINAL AND UNPUBLISHED WORK OF OHM AND THE SAME MAY NOT BE DUPLICATED, DISTRIBUTED, OR DISCLOSED WITHOUT PRIOR WRITTEN CONSENT OF OHM

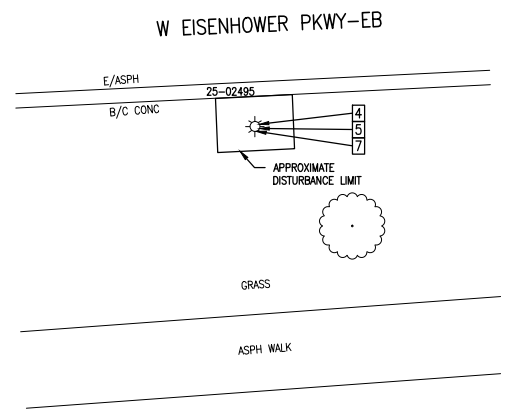

#1 - W EISENHOWER PKWY-EB  
WEST OF S MAIN ST

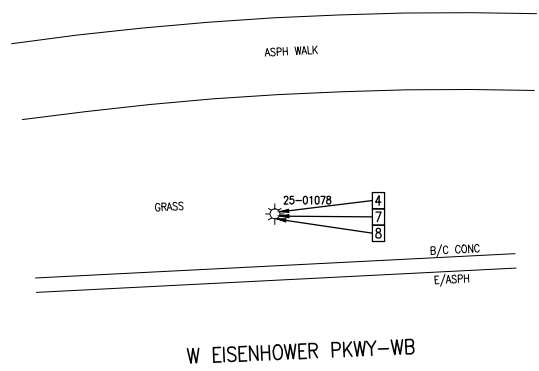

#2 - W EISENHOWER PKWY-WB  
FIRST STREET LIGHT EAST OF S MAIN ST

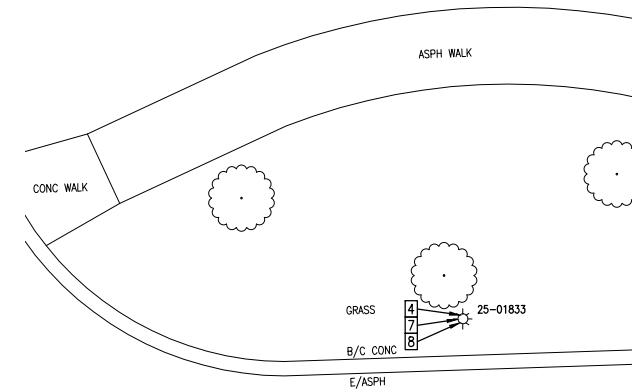

#3 - W EISENHOWER PKWY-WB AT  
BURLINGTON WOODS CIR

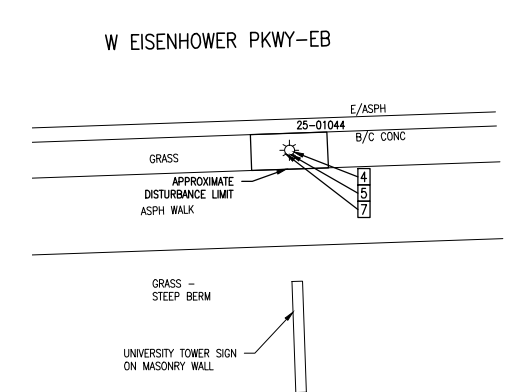

#4 - E EISENHOWER PKWY-EB  
EAST OF S STATE ST

**REMOVAL KEY**

- 1 CONCRETE WALK, REMOVE
- 2 BRICK PAVER WALK, REMOVE & SALVAGE
- 3 PAVEMENT, REMOVE
- 4 LIGHT POLE, REMOVE
- 5 FOUNDATION, REMOVE
- 6 FIXTURE, REMOVE
- 7 FIXTURE, REMOVE & SALVAGE
- 8 FOUNDATION, PROTECT
- 9 HANDHOLE, REMOVE
- 10 LIGHT POLE, REMOVE & SALVAGE
- 11 LIGHT POLE, PROTECT

**REMOVAL PLAN**

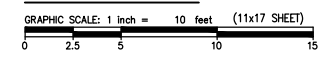

**QUANTITIES THIS SHEET**

TOTAL	UNIT	DESCRIPTION
2	Ea	Foundation, Rem
4	Ea	Light Pole, Rem
2	Ea	Foundation, Light Pole
4	Ea	Light Pole, LP3
4	Ea	Fixture, Reinstall

**CONSTRUCTION KEY**

- 1 CONCRETE WALK
- 2 BRICK PAVER WALK, REINSTALL
- 3 ADA RAMP
- 4 CONCRETE PAVEMENT
- 5 HMA PAVEMENT
- 6 TOPSOIL, SEED & MULCH
- 7 POLE FOUNDATION
- 8 LIGHT POLE, LP1
- 9 LIGHT POLE, LP2
- 10 LIGHT POLE, LP3
- 11 FIXTURE, REINSTALL
- 12 FIXTURE, SL1
- 13 FIXTURE, SL2
- 14 FIXTURE, SL3
- 15 HANDHOLE
- 16 LIGHT POLE, REINSTALL

**CONSTRUCTION PLAN**

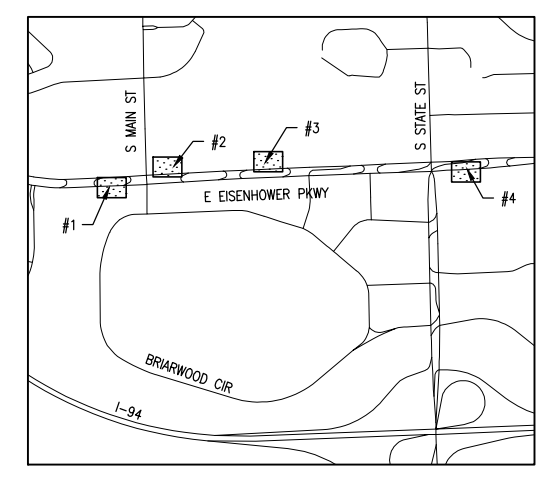
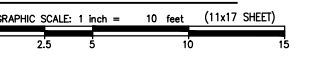

**KEY PLAN**  
NOT TO SCALE

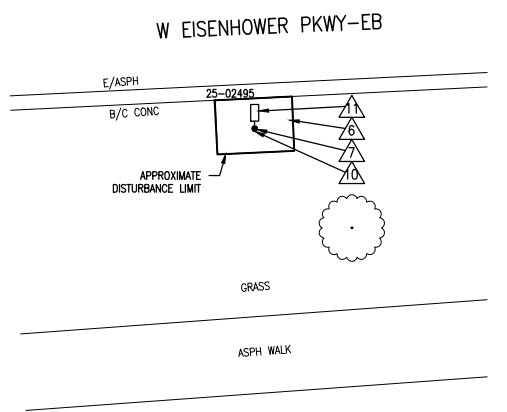

#1 - W EISENHOWER PKWY-EB  
WEST OF S MAIN ST

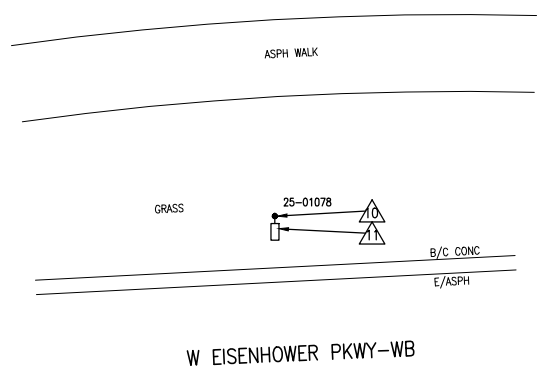

#2 - W EISENHOWER PKWY-WB  
FIRST STREET LIGHT EAST OF S MAIN ST

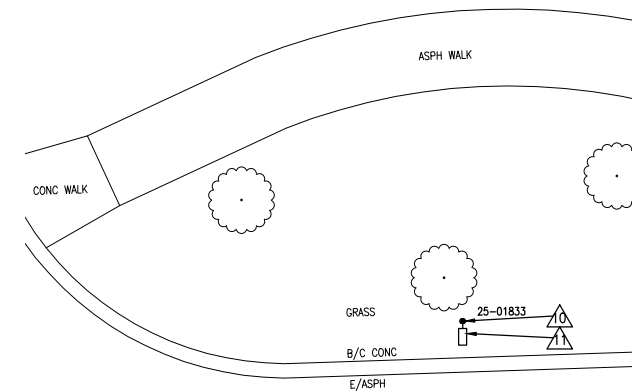

#3 - W EISENHOWER PKWY-WB AT  
BURLINGTON WOODS CIR

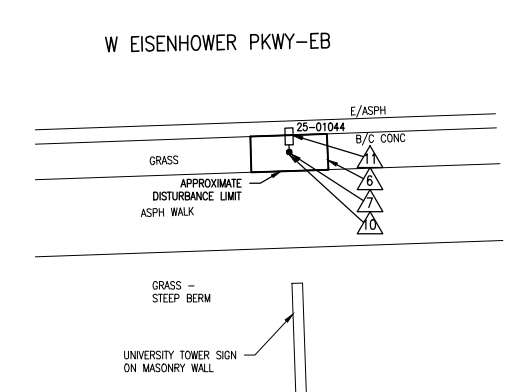

#4 - E EISENHOWER PKWY-EB  
EAST OF S STATE ST

REVISIONS:  
 11-28-18 BID SET  
 12-14-18 ADDENDUM No. 1 REVISIONS

CITY OF ANN ARBOR  
 ITB NO. 4557 2019 STREET LIGHT REPLACEMENT  
 REMOVAL & CONSTRUCTION PLAN



DRAWING PATH: P:\0000\_01000028180040\_44\_Street\_LL\_Recipie\_FY\_19\_CIPDrawings\CityPlans\_Consist\80040CON\_01.dwg Date: 13, 2018 - 9:50am

COPYRIGHT 2017 OHM ALL DRAWINGS AND WRITTEN MATERIALS APPEARING HEREIN CONSTITUTE THE ORIGINAL AND UNPUBLISHED WORK OF OHM AND THE SAME MAY NOT BE DUPLICATED, DISTRIBUTED, OR DISCLOSED WITHOUT PRIOR WRITTEN CONSENT OF OHM

W EISENHOWER PKWY-EB

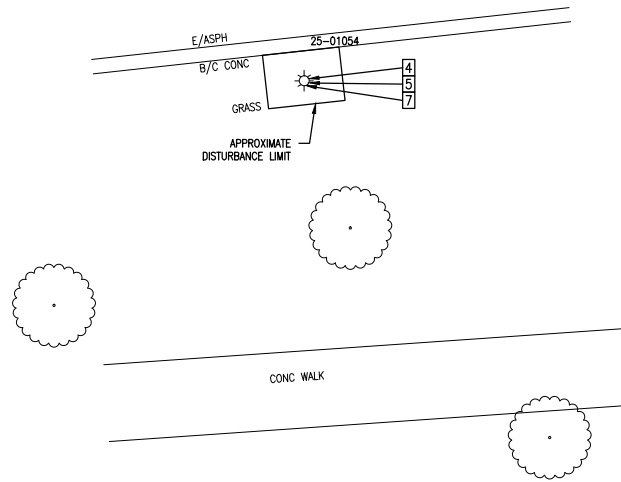

#1 - E EISENHOWER PKWY-EB WEST OF BOARDWALK DR

NOTE: POLE LOCATION 25-00891 MAY HAVE DAMAGED WIRES TO BE ADDRESSED DURING CONSTRUCTION

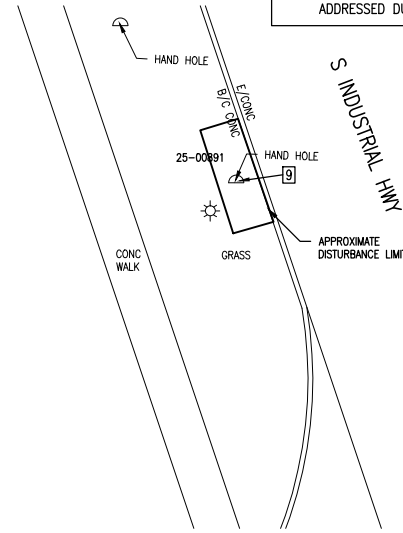

#2 - S INDUSTRIAL HWY ACROSS FROM 2805 S INDUSTRIAL HWY

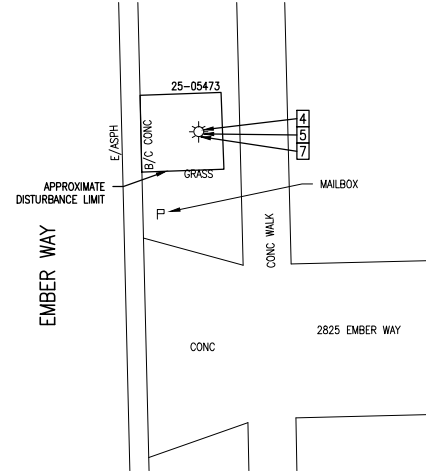

#3 - AT 2825 EMBER WAY

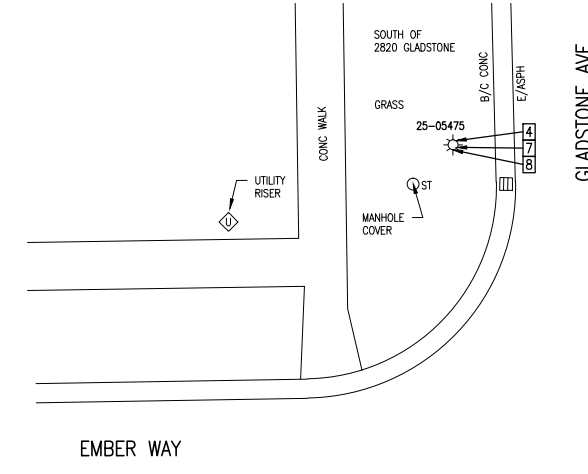

#4 - NW CORNER OF GLADSTONE AVE & EMBER WAY INTERSECTION

**REMOVAL KEY**

- 1 CONCRETE WALK, REMOVE
- 2 BRICK PAVER WALK, REMOVE & SALVAGE
- 3 PAVEMENT, REMOVE
- 4 LIGHT POLE, REMOVE
- 5 FOUNDATION, REMOVE
- 6 FIXTURE, REMOVE
- 7 FIXTURE, REMOVE & SALVAGE
- 8 FOUNDATION, PROTECT
- 9 HANDHOLE, REMOVE
- 10 LIGHT POLE, REMOVE & SALVAGE
- 11 LIGHT POLE, PROTECT

**REMOVAL PLAN**

GRAPHIC SCALE: 1 inch = 10 feet (11x17 SHEET)

**QUANTITIES THIS SHEET**

TOTAL	UNIT	DESCRIPTION
1	Ea	Handhole, Rem
2	Ea	Foundation, Rem
3	Ea	Light Pole, Rem
1	Ea	Handhole, Streetlight
2	Ea	Foundation, Light Pole
3	Ea	Light Pole, LP3
3	Ea	Fixture, Reinstall

**CONSTRUCTION KEY**

- 1 CONCRETE WALK
- 2 BRICK PAVER WALK, REINSTALL
- 3 ADA RAMP
- 4 CONCRETE PAVEMENT
- 5 HMA PAVEMENT
- 6 TOPSOIL, SEED & MULCH
- 7 POLE FOUNDATION
- 8 LIGHT POLE, LP1
- 9 LIGHT POLE, LP2
- 10 LIGHT POLE, LP3
- 11 FIXTURE, REINSTALL
- 12 FIXTURE, SL1
- 13 FIXTURE, SL2
- 14 FIXTURE, SL3
- 15 HANDHOLE
- 16 LIGHT POLE, REINSTALL

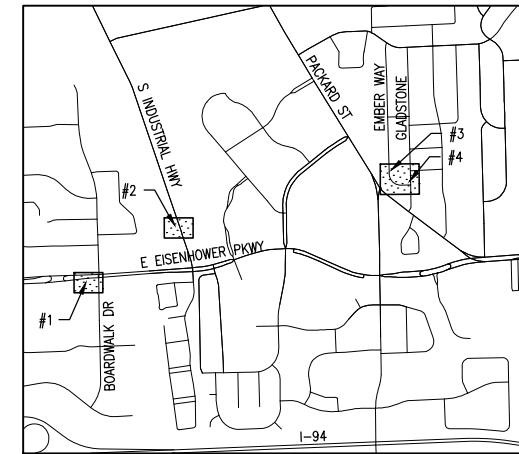

**KEY PLAN**  
NOT TO SCALE

W EISENHOWER PKWY-EB

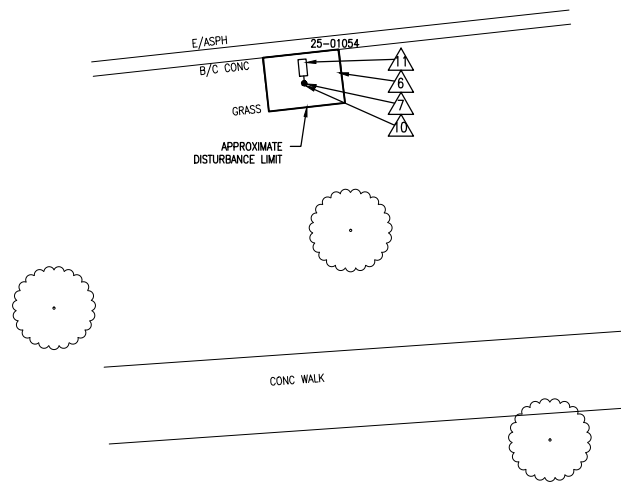

#1 - E EISENHOWER PKWY-EB WEST OF BOARDWALK DR

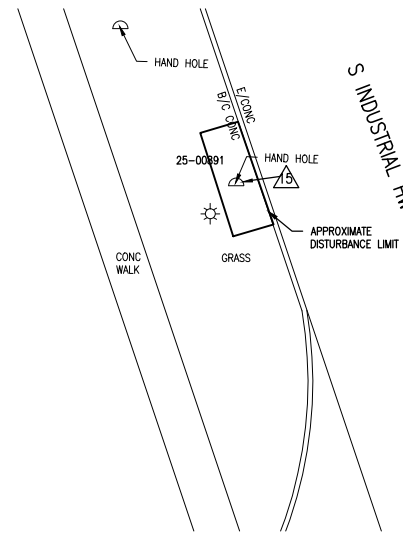

#2 - S INDUSTRIAL HWY ACROSS FROM 2805 S INDUSTRIAL HWY

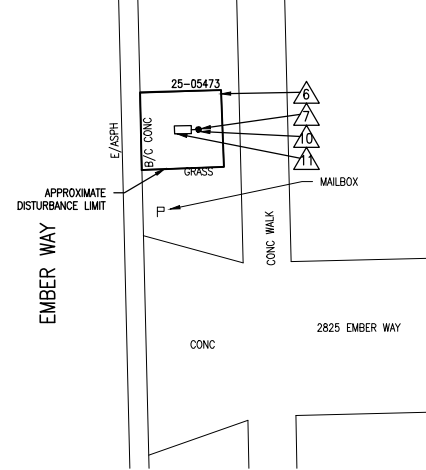

#3 - AT 2825 EMBER WAY

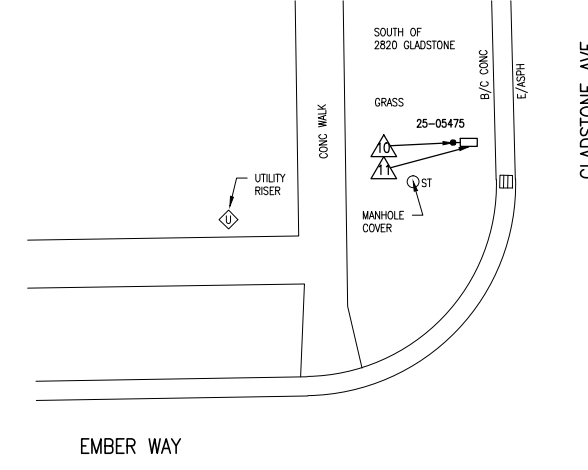

#4 - NW CORNER OF GLADSTONE AVE & EMBER WAY INTERSECTION

**CONSTRUCTION PLAN**

GRAPHIC SCALE: 1 inch = 10 feet (11x17 SHEET)



Know what's below.  
Call before you dig.

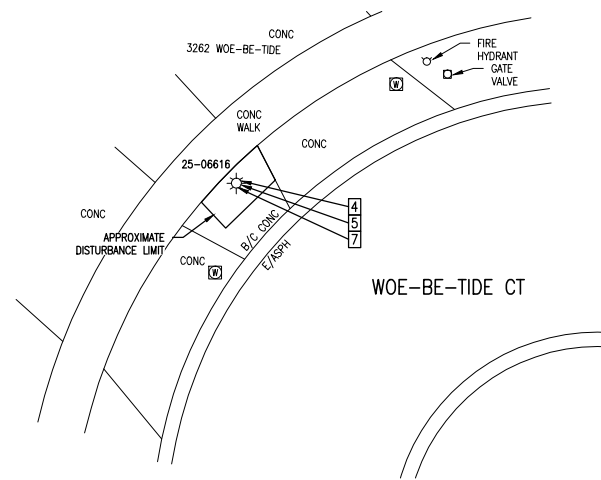

#1 - INNER PORTION OF WOE-BE-TIDE CT

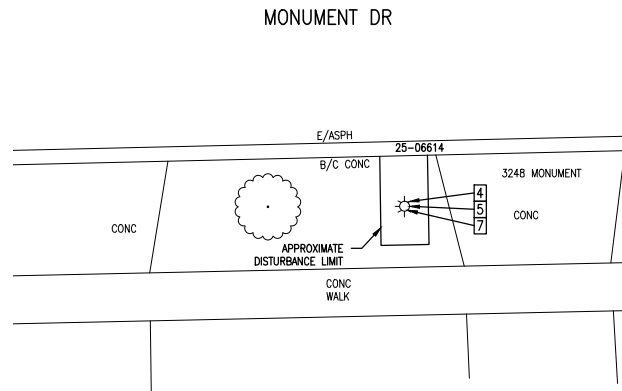

#2 - MONUMENT DR WEST OF TURNBERRY LN

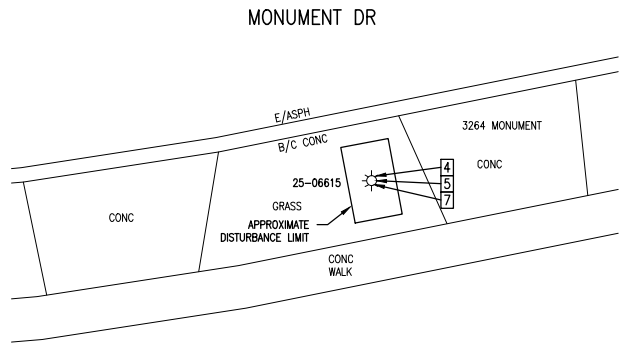

#3 - MONUMENT DR WEST OF TURNBERRY LN

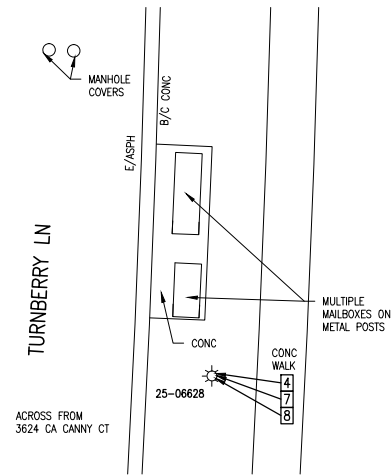

#4 - TURNBERRY LN NORTH OF CA CANNY CT

**REMOVAL KEY**

- 1 CONCRETE WALK, REMOVE
- 2 BRICK PAVER WALK, REMOVE & SALVAGE
- 3 PAVEMENT, REMOVE
- 4 LIGHT POLE, REMOVE
- 5 FOUNDATION, REMOVE
- 6 FIXTURE, REMOVE
- 7 FIXTURE, REMOVE & SALVAGE
- 8 FOUNDATION, PROTECT
- 9 HANDHOLE, REMOVE
- 10 LIGHT POLE, REMOVE & SALVAGE
- 11 LIGHT POLE, PROTECT

**REMOVAL PLAN**

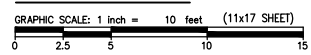

**QUANTITIES THIS SHEET**

TOTAL	UNIT	DESCRIPTION
3	Ea	Foundation, Rem
4	Ea	Light Pole, Rem
3	Ea	Foundation, Light Pole
4	Ea	Light Pole, LP3
4	Ea	Fixture, Reinstall

**CONSTRUCTION KEY**

- 1 CONCRETE WALK
- 2 BRICK PAVER WALK, REINSTALL
- 3 ADA RAMP
- 4 CONCRETE PAVEMENT
- 5 HMA PAVEMENT
- 6 TOPSOIL, SEED & MULCH
- 7 POLE FOUNDATION
- 8 LIGHT POLE, LP1
- 9 LIGHT POLE, LP2
- 10 LIGHT POLE, LP3
- 11 FIXTURE, REINSTALL
- 12 FIXTURE, SL1
- 13 FIXTURE, SL2
- 14 FIXTURE, SL3
- 15 HANDHOLE
- 16 LIGHT POLE, REINSTALL

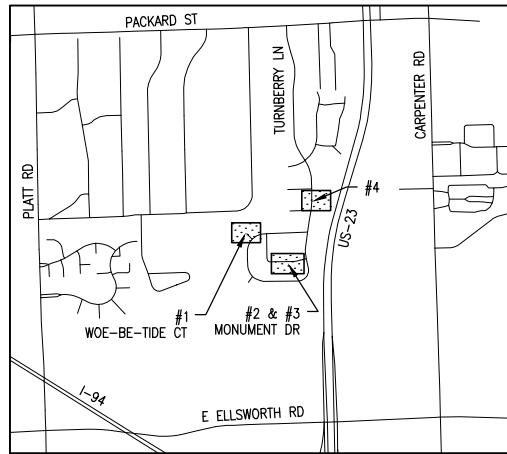

**KEY PLAN**  
NOT TO SCALE

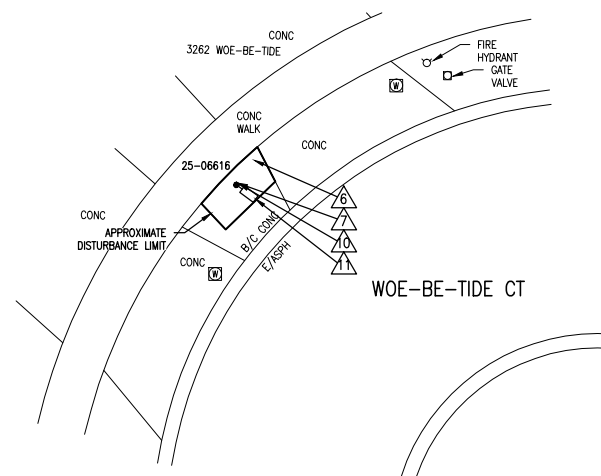

#1 - INNER PORTION OF WOE-BE-TIDE CT

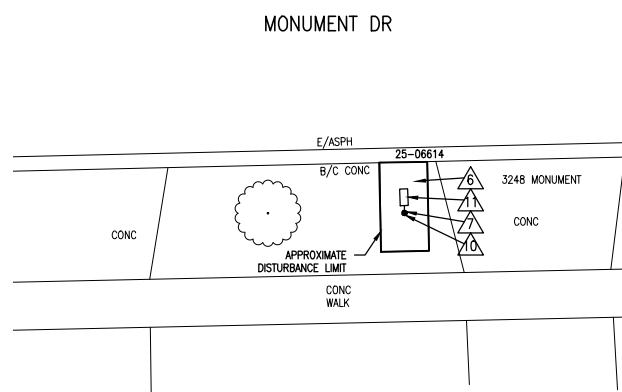

#2 - MONUMENT DR WEST OF TURNBERRY LN

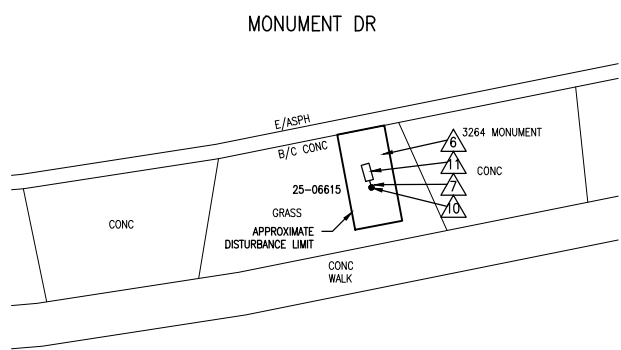

#3 - MONUMENT DR WEST OF TURNBERRY LN

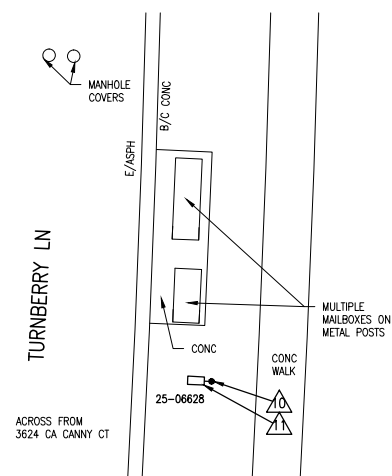

#4 - TURNBERRY LN NORTH OF CA CANNY CT

**CONSTRUCTION PLAN**

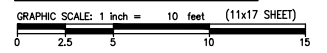

REVISIONS:  
 11-28-18 BID SET  
 12-14-18 ADDENDUM No. 1 REVISIONS

CITY OF ANN ARBOR  
 ITB NO. 4557 2019 STREET LIGHT REPLACEMENT  
 REMOVAL & CONSTRUCTION PLAN

DRAWING PATH: P:\0000\_01000028180040\_44\_Street\_LL\_Replic\_EY\_19\_CIPDrawings\ChilPlans\_Consist\80040CON\_01.dwg Date: 13, 2018 9:43am

COPYRIGHT 2017 OHM ALL DRAWINGS AND WRITTEN MATERIALS APPEARING HEREIN CONSTITUTE THE ORIGINAL AND UNPUBLISHED WORK OF OHM AND THE SAME MAY NOT BE DUPLICATED, DISTRIBUTED, OR DISCLOSED WITHOUT PRIOR WRITTEN CONSENT OF OHM

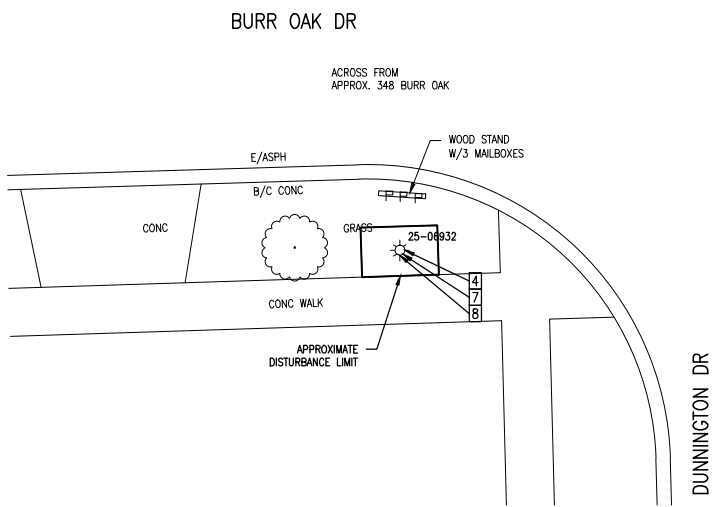

#1 - SW CORNER OF BURR OAK DR & DUNNINGTON DR

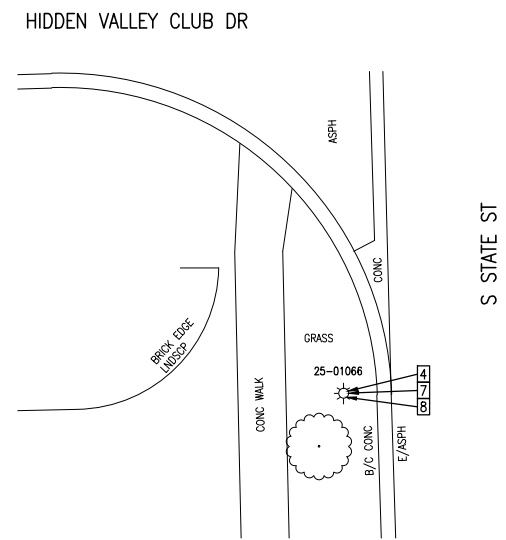

#2 - SW CORNER OF S STATE ST & HIDDEN VALLEY CLUB DR

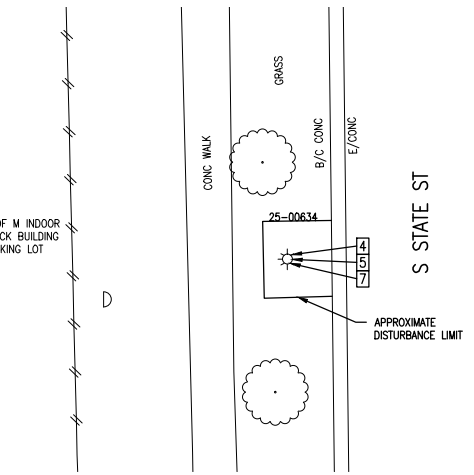

#3 - S STATE ST FIRST POLE NORTHWEST OF VOLKSWAGEN OF ANN ARBOR 2565 S STATE ST

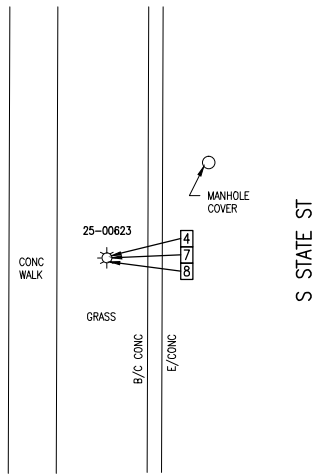

#4 - ACROSS FROM ARBOR HILLS HAIR & BODY SALON 2295 S STATE ST

**REMOVAL KEY**

- 1 CONCRETE WALK, REMOVE
- 2 BRICK PAVER WALK, REMOVE & SALVAGE
- 3 PAVEMENT, REMOVE
- 4 LIGHT POLE, REMOVE
- 5 FOUNDATION, REMOVE
- 6 FIXTURE, REMOVE
- 7 FIXTURE, REMOVE & SALVAGE
- 8 FOUNDATION, PROTECT
- 9 HANDHOLE, REMOVE
- 10 LIGHT POLE, REMOVE & SALVAGE
- 11 LIGHT POLE, PROTECT

**CONSTRUCTION KEY**

- 1 CONCRETE WALK
- 2 BRICK PAVER WALK, REINSTALL
- 3 ADA RAMP
- 4 CONCRETE PAVEMENT
- 5 HMA PAVEMENT
- 6 TOPSOIL, SEED & MULCH
- 7 POLE FOUNDATION
- 8 LIGHT POLE, LP1
- 9 LIGHT POLE, LP2
- 10 LIGHT POLE, LP3
- 11 FIXTURE, REINSTALL
- 12 FIXTURE, SL1
- 13 FIXTURE, SL2
- 14 FIXTURE, SL3
- 15 HANDHOLE
- 16 LIGHT POLE, REINSTALL

**REMOVAL PLAN**

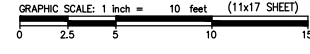

**QUANTITIES THIS SHEET**

TOTAL	UNIT	DESCRIPTION
1	Ea	Foundation, Rem
4	Ea	Light Pole, Rem
1	Ea	Foundation, Light Pole
4	Ea	Light Pole, LP3
4	Ea	Fixture, Reinstall

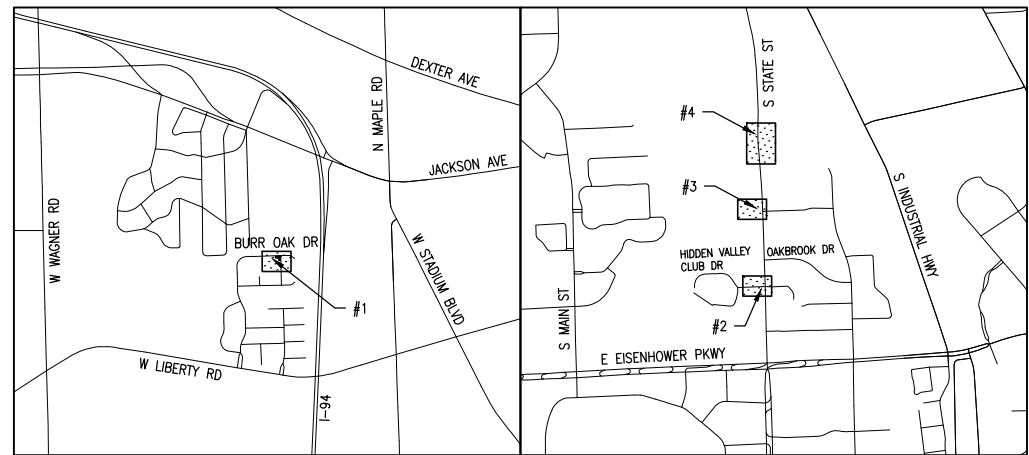

**KEY PLAN**  
NOT TO SCALE

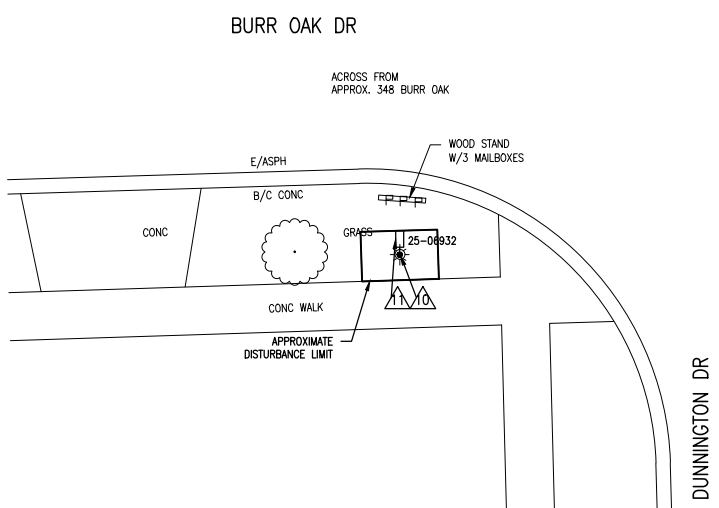

#1 - SW CORNER OF BURR OAK DR & DUNNINGTON DR

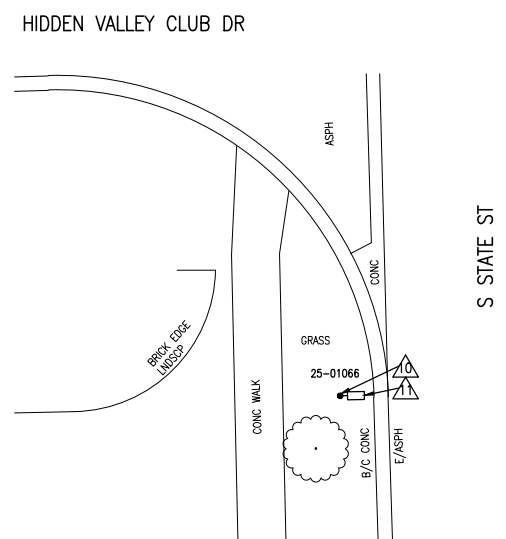

#2 - SW CORNER OF S STATE ST & HIDDEN VALLEY CLUB DR

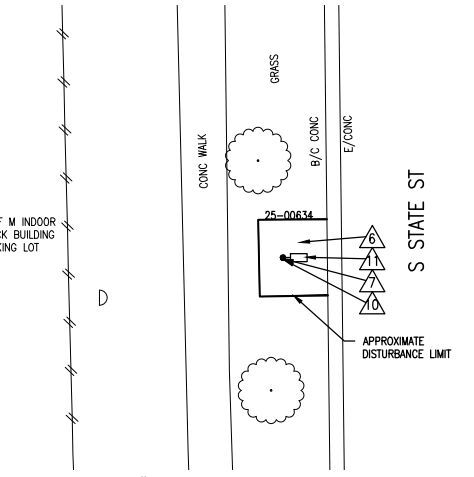

#3 - S STATE ST FIRST POLE NORTHWEST OF VOLKSWAGEN OF ANN ARBOR 2565 S STATE ST

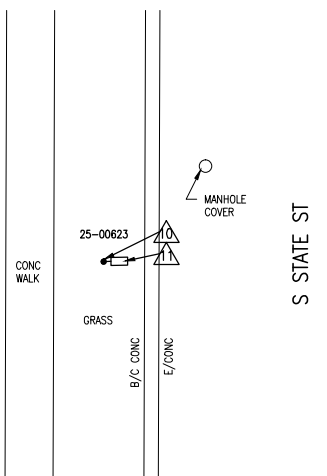

#4 - ACROSS FROM ARBOR HILLS HAIR & BODY SALON 2295 S STATE ST

**CONSTRUCTION PLAN**

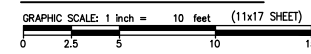

Know what's below.  
Call before you dig.

REVISIONS:  
 11-28-18 BID SET  
 12-14-18 ADDENDUM No. 1 REVISIONS

CITY OF ANN ARBOR  
 ITB NO. 4557 2019 STREET LIGHT REPLACEMENT  
 REMOVAL & CONSTRUCTION PLAN

DRAWING PATH: P:\0000\_01000028180040\_44\_Street\_LL\_Replic\_EY\_19\_CIPDrawings\ChilPlans\_Consist\80040CON\_01.dwg Date: 12/13/2018 9:43am

COPYRIGHT 2017 OHM ALL DRAWINGS AND WRITTEN MATERIALS APPEARING HEREIN CONSTITUTE THE ORIGINAL AND UNPUBLISHED WORK OF OHM AND THE SAME MAY NOT BE DUPLICATED, DISTRIBUTED, OR DISCLOSED WITHOUT PRIOR WRITTEN CONSENT OF OHM

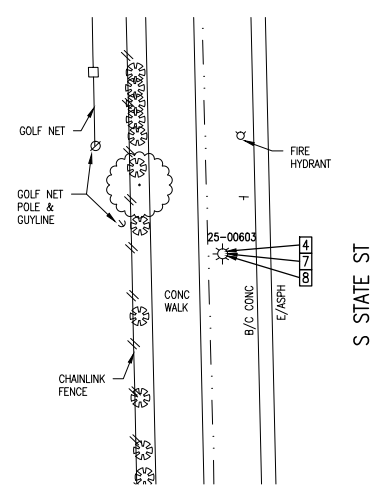

#1 - ACROSS FROM NORTH ENTRANCE OF THE PRODUCE STATION  
 1629 S STATE ST

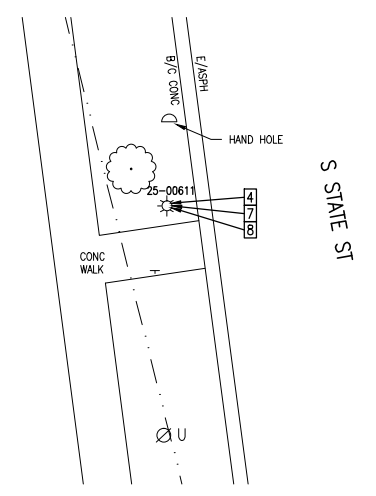

#2 - S STATE ST BUS STOP AT DANIELS & ZERMACK ARCHITECTS  
 2080 S STATE ST

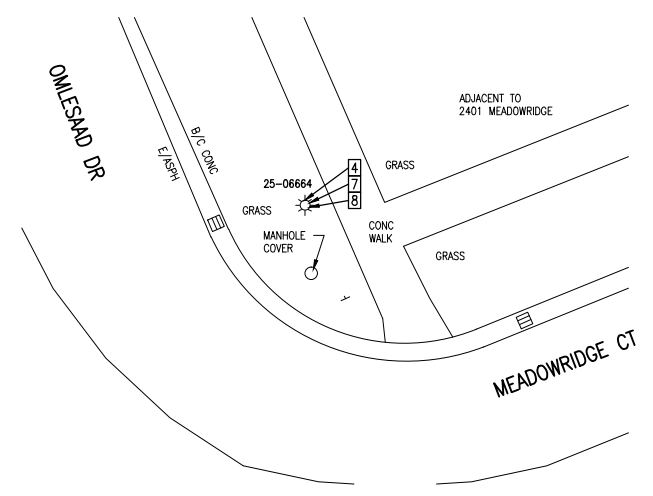

#3 - OMLESAAD DR AT MEADOWRIDGE CT

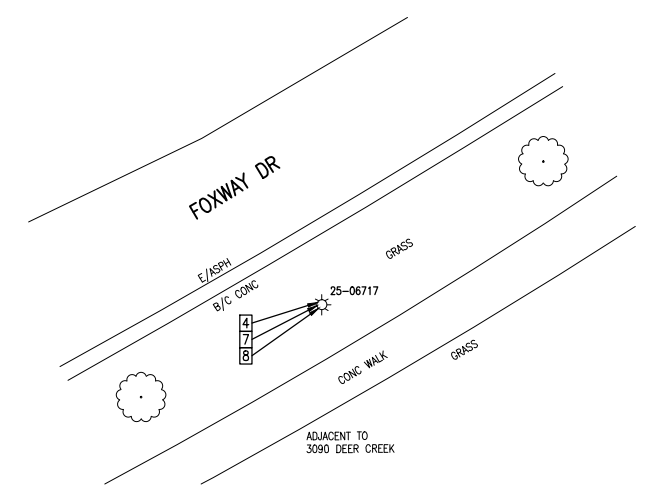

#4 - FOXWAY DR EAST OF HOME AT DEER CREEK CT INTERSECTION

**REMOVAL KEY**

- 1 CONCRETE WALK, REMOVE
- 2 BRICK PAVER WALK, REMOVE & SALVAGE
- 3 PAVEMENT, REMOVE
- 4 LIGHT POLE, REMOVE
- 5 FOUNDATION, REMOVE
- 6 FIXTURE, REMOVE
- 7 FIXTURE, REMOVE & SALVAGE
- 8 FOUNDATION, PROTECT
- 9 HANDHOLE, REMOVE
- 10 LIGHT POLE, REMOVE & SALVAGE
- 11 LIGHT POLE, PROTECT

**CONSTRUCTION KEY**

- 1 CONCRETE WALK
- 2 BRICK PAVER WALK, REINSTALL
- 3 ADA RAMP
- 4 CONCRETE PAVEMENT
- 5 HMA PAVEMENT
- 6 TOPSOIL, SEED & MULCH
- 7 POLE FOUNDATION
- 8 LIGHT POLE, LP1
- 9 LIGHT POLE, LP2
- 10 LIGHT POLE, LP3
- 11 FIXTURE, REINSTALL
- 12 FIXTURE, SL1
- 13 FIXTURE, SL2
- 14 FIXTURE, SL3
- 15 HANDHOLE
- 16 LIGHT POLE, REINSTALL

**REMOVAL PLAN**

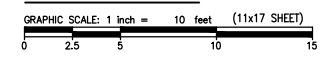

**QUANTITIES THIS SHEET**

TOTAL	UNIT	DESCRIPTION
4	Ea	Light Pole, Rem
4	Ea	Light Pole, LP3
4	Ea	Fixture, Reinstall

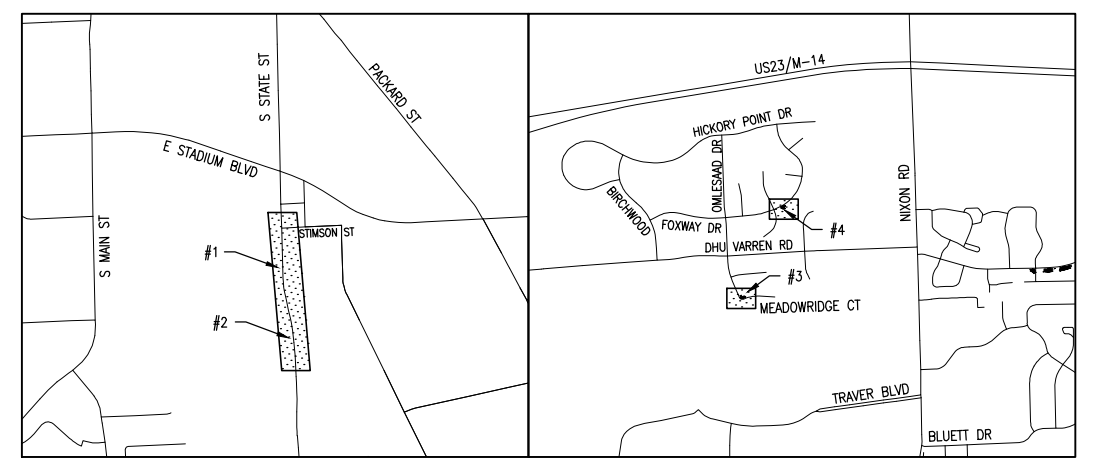

**KEY PLAN**  
 NOT TO SCALE

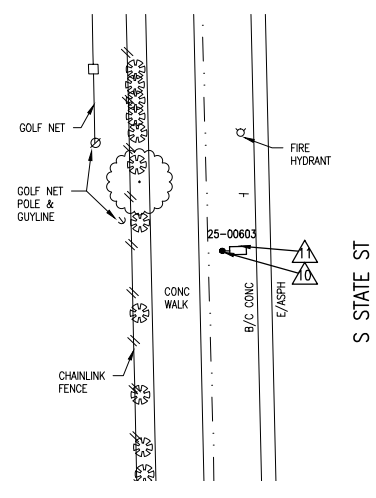

#1 - ACROSS FROM NORTH ENTRANCE OF THE PRODUCE STATION  
 1629 S STATE ST

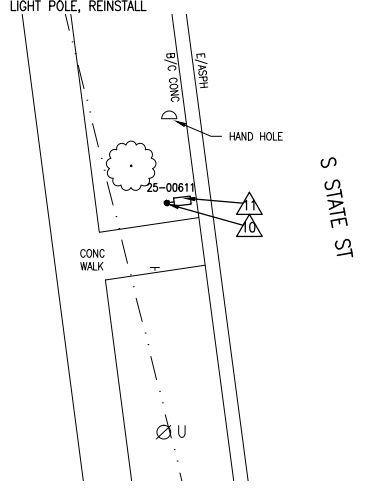

#3 - OMLESAAD DR AT MEADOWRIDGE CT

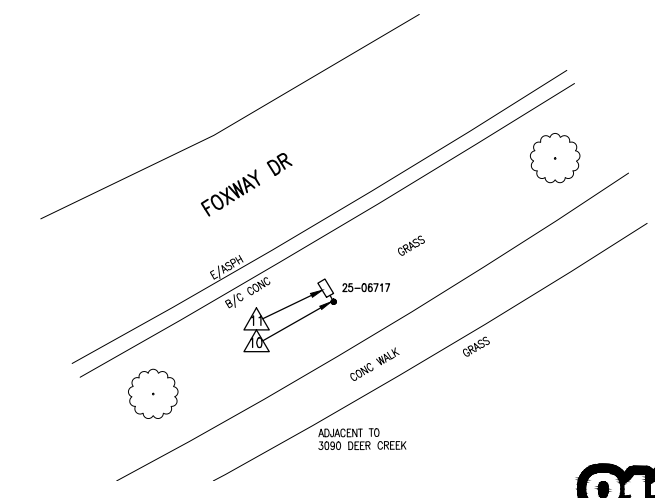

#4 - FOXWAY DR EAST OF HOME AT DEER CREEK CT INTERSECTION

**CONSTRUCTION PLAN**

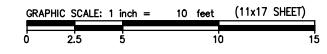

Know what's below.  
 Call before you dig.

REVISIONS:  
 11-28-18 BID SET  
 12-14-18 ADDENDUM No. 1 REVISIONS

CITY OF ANN ARBOR  
 ITB NO. 4557 2019 STREET LIGHT REPLACEMENT  
 REMOVAL & CONSTRUCTION PLAN

DRAWING PATH: P:\0000\_01000028180040\_44\_Street\_LL\Revised\_EY\_19\_CIP\Drawings\ChiliPlans\_Consist\80040CON\_01.dwg Date: 12/13/2018 9:43am

COPYRIGHT 2017 OHM ALL DRAWINGS AND WRITTEN MATERIALS APPEARING HEREIN CONSTITUTE THE ORIGINAL AND UNPUBLISHED WORK OF OHM AND THE SAME MAY NOT BE DUPLICATED, DISTRIBUTED, OR DISCLOSED WITHOUT PRIOR WRITTEN CONSENT OF OHM

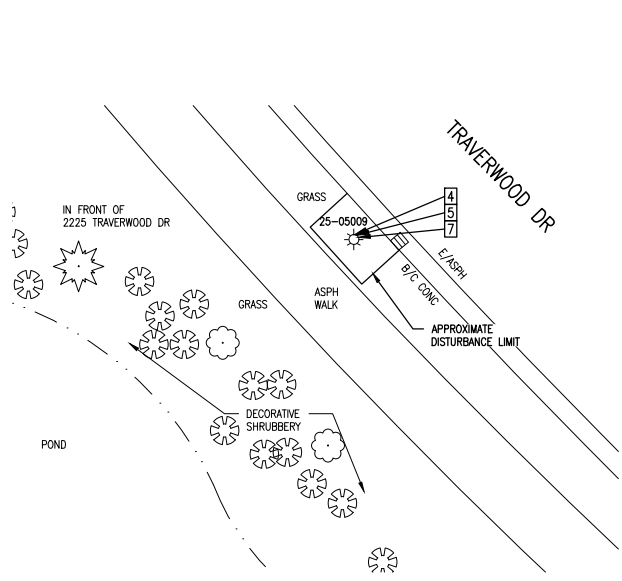

#1 - TRAVERWOOD DR SOUTH OF NORTH DEVON CIR INTERSECTION

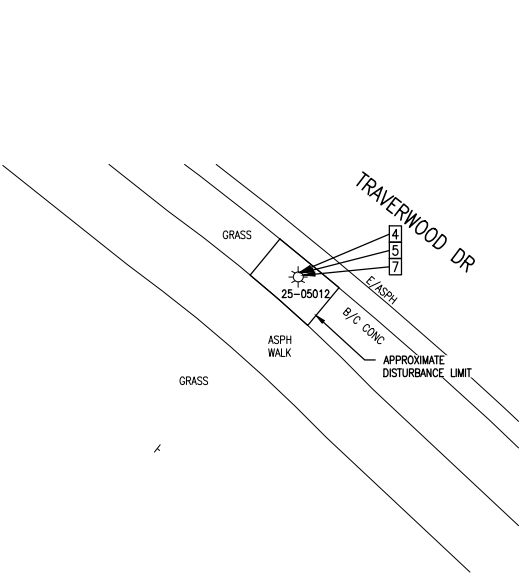

#2 - TRAVERWOOD DR ACROSS FROM U OF M ALCOHOL MGMT 2025 TRAVERWOOD DR

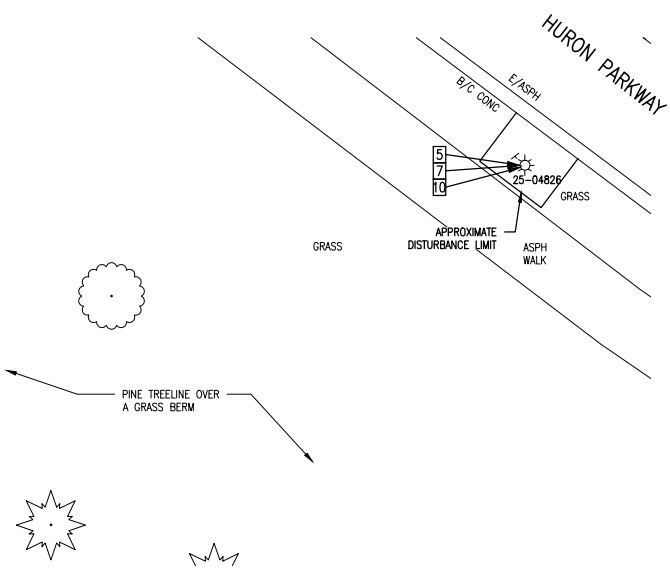

#3 - HURON PKWY 100 FT EAST OF WEST DRIVEWAY TO KROGER 2641 PLYMOUTH RD

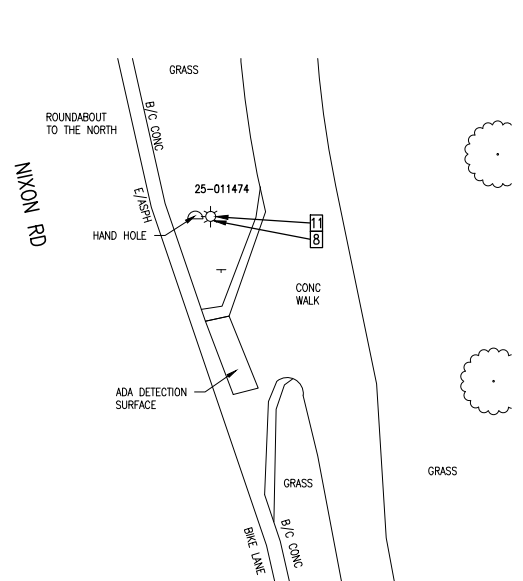

#4 - NIXON RD BIKE MERGE SOUTH OF HURON PKWY & PEDESTRIAN CROSSWALK

**REMOVAL KEY**

- 1 CONCRETE WALK, REMOVE
- 2 BRICK PAVER WALK, REMOVE & SALVAGE
- 3 PAVEMENT, REMOVE
- 4 LIGHT POLE, REMOVE
- 5 FOUNDATION, REMOVE
- 6 FIXTURE, REMOVE
- 7 FIXTURE, REMOVE & SALVAGE
- 8 FOUNDATION, PROTECT
- 9 HANDHOLE, REMOVE
- 10 LIGHT POLE, REMOVE & SALVAGE
- 11 LIGHT POLE, PROTECT

**CONSTRUCTION KEY**

- 1 CONCRETE WALK
- 2 BRICK PAVER WALK, REINSTALL
- 3 ADA RAMP
- 4 CONCRETE PAVEMENT
- 5 HMA PAVEMENT
- 6 TOPSOIL, SEED & MULCH
- 7 POLE FOUNDATION
- 8 LIGHT POLE, LP1
- 9 LIGHT POLE, LP2
- 10 LIGHT POLE, LP3
- 11 FIXTURE, REINSTALL
- 12 FIXTURE, SL1
- 13 FIXTURE, SL2
- 14 FIXTURE, SL3
- 15 HANDHOLE
- 16 LIGHT POLE, REINSTALL

**REMOVAL PLAN**

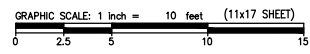

**QUANTITIES THIS SHEET**

TOTAL	UNIT	DESCRIPTION
3	Ea	Foundation, Rem
2	Ea	Light Pole, Rem
3	Ea	Foundation, Light Pole
2	Ea	Light Pole, LP3
3	Ea	Fixture, Reinstall

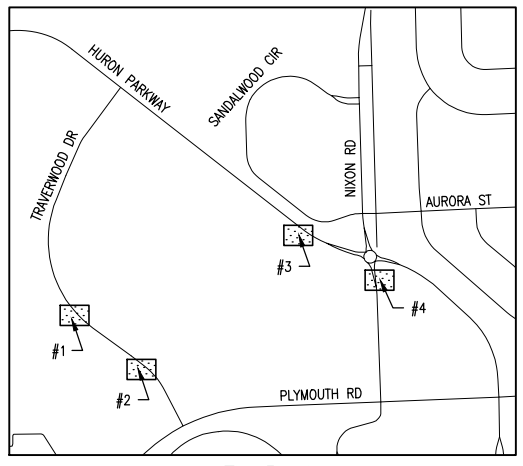

**KEY PLAN**  
NOT TO SCALE

NOTE: POLE LOCATION 25-011474 HAS A LOOSE BRACKET AT POLE ARM. PROVIDE NEW HARDWARE KIT IF NECESSARY

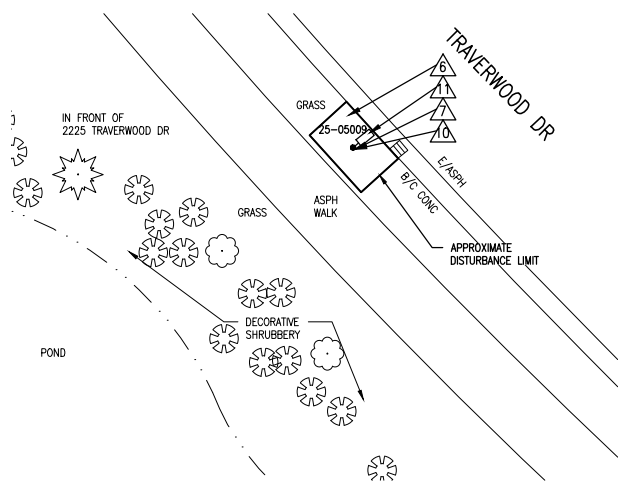

#1 - TRAVERWOOD DR SOUTH OF NORTH DEVON CIR INTERSECTION

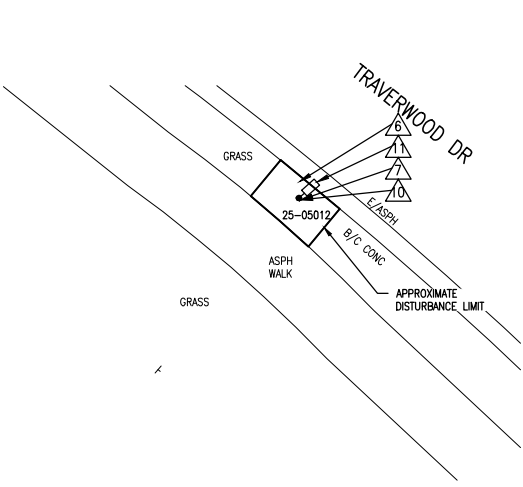

#2 - TRAVERWOOD DR ACROSS FROM U OF M ALCOHOL MGMT 2025 TRAVERWOOD DR

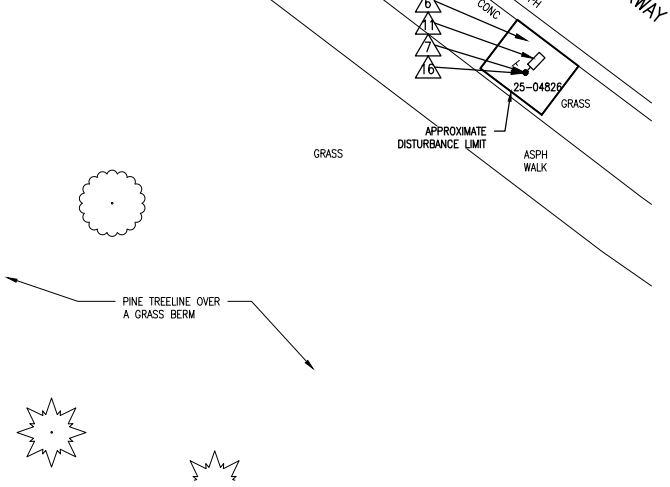

#3 - HURON PKWY 100 FT EAST OF WEST DRIVEWAY TO KROGER 2641 PLYMOUTH RD

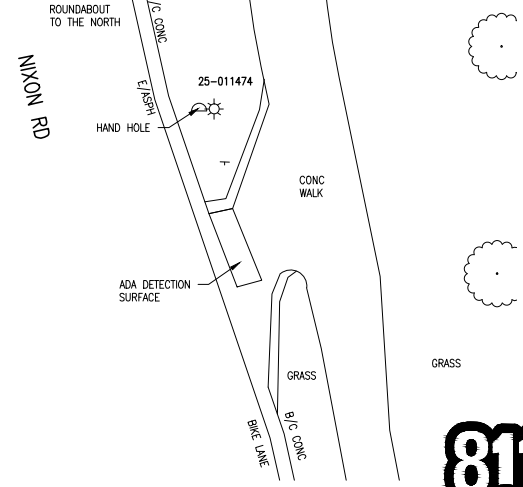

#4 - NIXON RD BIKE MERGE SOUTH OF HURON PKWY & PEDESTRIAN CROSSWALK

**CONSTRUCTION PLAN**

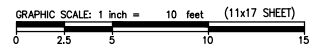

REVISIONS:  
 11-28-18 BID SET  
 12-14-18 ADDENDUM No. 1 REVISIONS

CITY OF ANN ARBOR  
 ITB NO. 4557 2019 STREET LIGHT REPLACEMENT  
 REMOVAL & CONSTRUCTION PLAN

DRAWING PATH: P:\0000\_01000028180040\_44\_Street\_LL\Replaces\_EY\_19\_CIP\Drawings\Civil\Plans\_Consist\800400CON\_03.dwg Date: 13, 2018 9:42am

COPYRIGHT 2017 OHM ALL DRAWINGS AND WRITTEN MATERIALS APPEARING HEREIN CONSTITUTE THE ORIGINAL AND UNPUBLISHED WORK OF OHM AND THE SAME MAY NOT BE DUPLICATED, DISTRIBUTED, OR DISCLOSED WITHOUT PRIOR WRITTEN CONSENT OF OHM

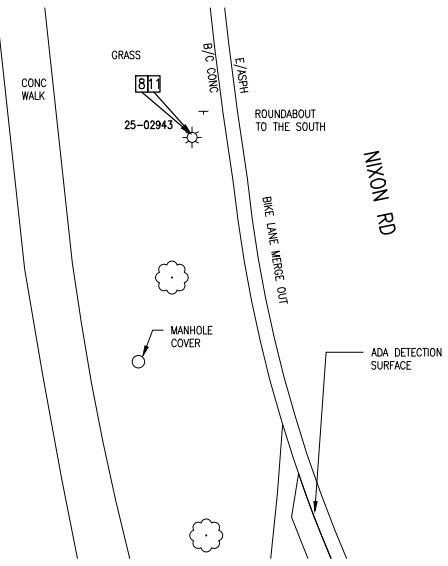

#1 - NIXON RD BIKE MERGE NORTH OF HURON PKWY & PEDESTRIAN CROSSWALK

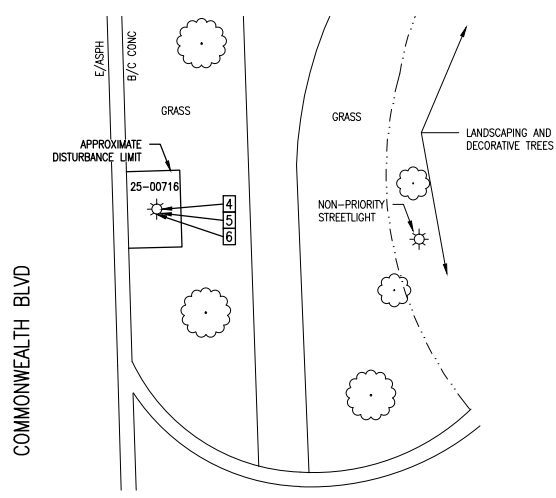

#2 - COMMONWEALTH BLVD SOUTH SIDE 2100 COMMONWEALTH BLVD PARKING

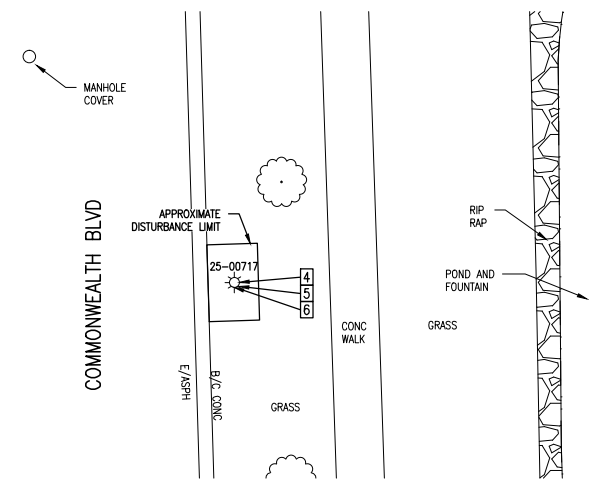

#3 - COMMONWEALTH BLVD ACROSS 2100 COMMONWEALTH BLVD PARKING

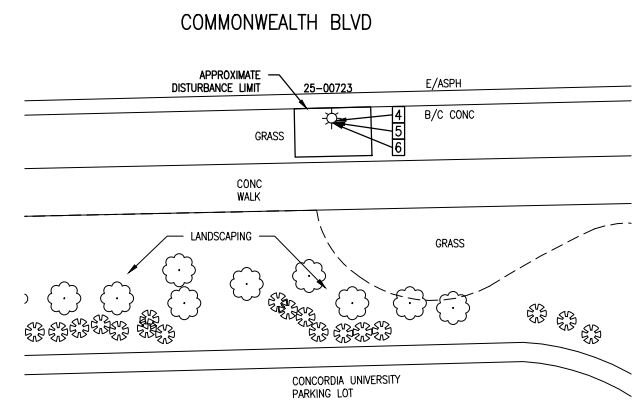

#4 - COMMONWEALTH BLVD WEST OF GREEN RD INTERSECTION

**REMOVAL KEY**

- 1 CONCRETE WALK, REMOVE
- 2 BRICK PAVER WALK, REMOVE & SALVAGE
- 3 PAVEMENT, REMOVE
- 4 LIGHT POLE, REMOVE
- 5 FOUNDATION, REMOVE
- 6 FIXTURE, REMOVE
- 7 FIXTURE, REMOVE & SALVAGE
- 8 FOUNDATION, PROTECT
- 9 HANDHOLE, REMOVE
- 10 LIGHT POLE, REMOVE & SALVAGE
- 11 LIGHT POLE, PROTECT

**CONSTRUCTION KEY**

- 1 CONCRETE WALK
- 2 BRICK PAVER WALK, REINSTALL
- 3 ADA RAMP
- 4 CONCRETE PAVEMENT
- 5 HMA PAVEMENT
- 6 TOPSOIL, SEED & MULCH
- 7 POLE FOUNDATION
- 8 LIGHT POLE, LP1
- 9 LIGHT POLE, LP2
- 10 LIGHT POLE, LP3
- 11 FIXTURE, REINSTALL
- 12 FIXTURE, SL1
- 13 FIXTURE, SL2
- 14 FIXTURE, SL3
- 15 HANDHOLE
- 16 LIGHT POLE, REINSTALL

**REMOVAL PLAN**

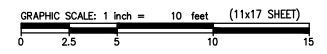

TOTAL	UNIT	DESCRIPTION
3	Ea	Foundation, Rem
3	Ea	Light Pole, Rem
3	Ea	Foundation, Light Pole
3	Ea	Light Pole, LP3
3	Ea	Fixture, SL3
1	Ea	Fixture, Reinstall

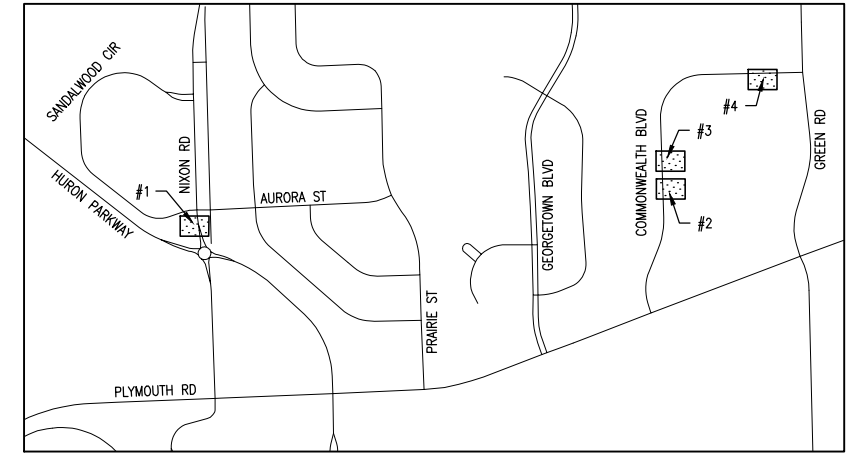

**KEY PLAN**  
NOT TO SCALE

NOTE: POLE LOCATION 25-02943 HAS LOOSE WIRING. TO BE ADDRESSED DURING CONSTRUCTION

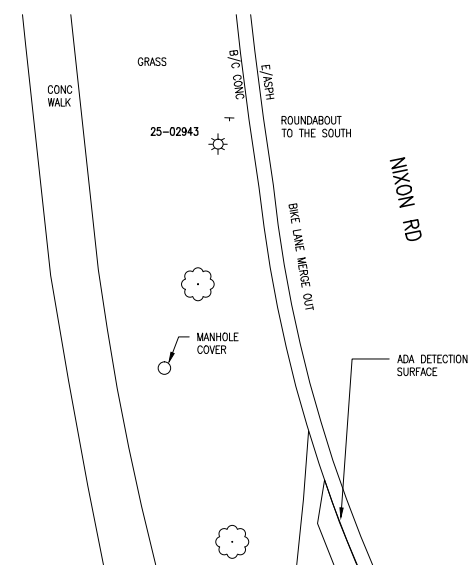

#1 - NIXON RD BIKE MERGE NORTH OF HURON PKWY & PEDESTRIAN CROSSWALK

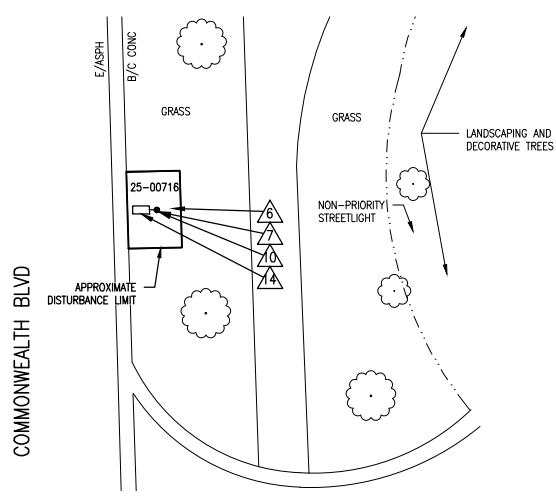

#2 - COMMONWEALTH BLVD SOUTH SIDE 2100 COMMONWEALTH BLVD PARKING

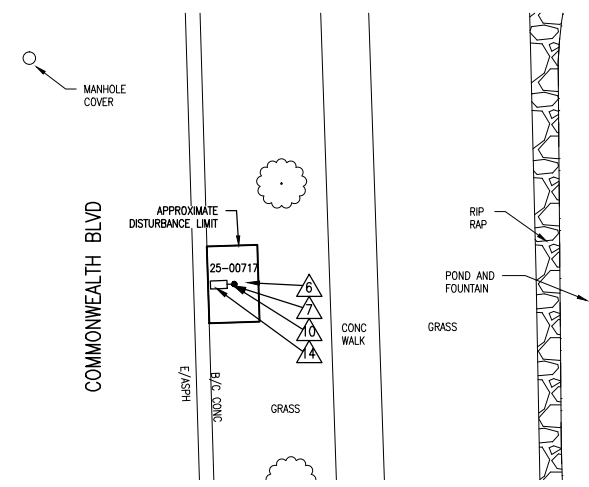

#3 - COMMONWEALTH BLVD ACROSS 2100 COMMONWEALTH BLVD PARKING

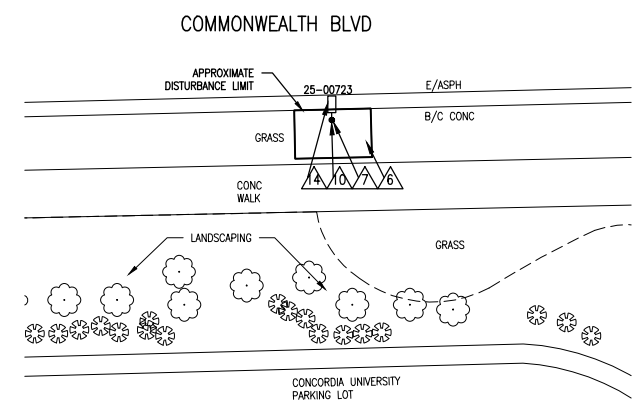

#4 - COMMONWEALTH BLVD WEST OF GREEN RD INTERSECTION

**CONSTRUCTION PLAN**

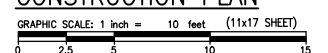

Know what's below.  
Call before you dig.

REVISIONS:  
11-28-18 BID SET  
12-14-18 ADDENDUM No. 1 REVISIONS

CITY OF ANN ARBOR  
ITB NO. 4557 2019 STREET LIGHT REPLACEMENT  
REMOVAL & CONSTRUCTION PLAN

DRAWING PATH: P:\0000\_01000028180040\_44\_Street\_LL\_Replic\_EY\_19\_CIPDrawings\Chil\Plans\_Cons\180040CON\_03.dwg Dec 13, 2018 9:42am

COPYRIGHT 2017 OHM ALL DRAWINGS AND WRITTEN MATERIALS APPEARING HEREIN CONSTITUTE THE ORIGINAL AND UNPUBLISHED WORK OF OHM AND THE SAME MAY NOT BE DUPLICATED, DISTRIBUTED, OR DISCLOSED WITHOUT PRIOR WRITTEN CONSENT OF OHM



DRAWING PATH: P:\0000\_010000028180040\_44\_Street\_LL\Revised\_EY\_19\_CIP\Drawings\Civil\Plans\_Consist\80040CON\_03.dwg Date: 13, 2018 9:42am

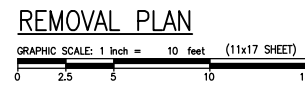
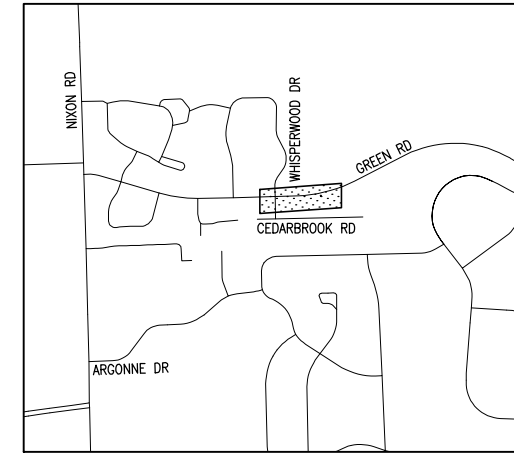
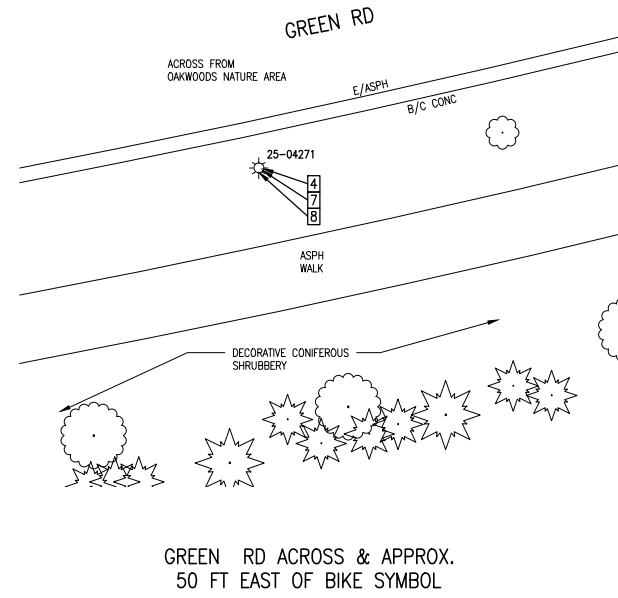
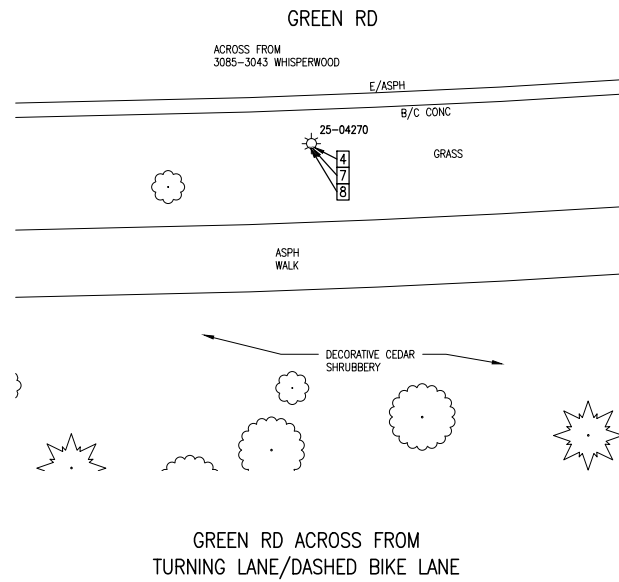
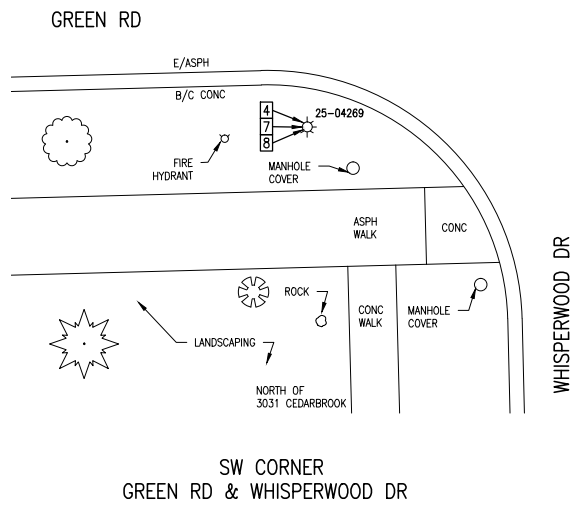

QUANTITIES THIS SHEET

TOTAL	UNIT	DESCRIPTION
3	Ea	Light Pole, Rem
3	Ea	Light Pole, LP3
3	Ea	Fixture, Reinstall

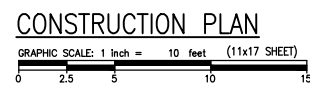
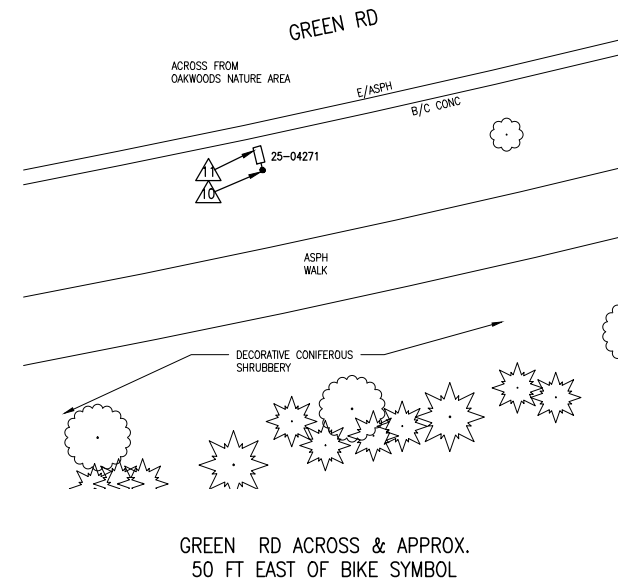
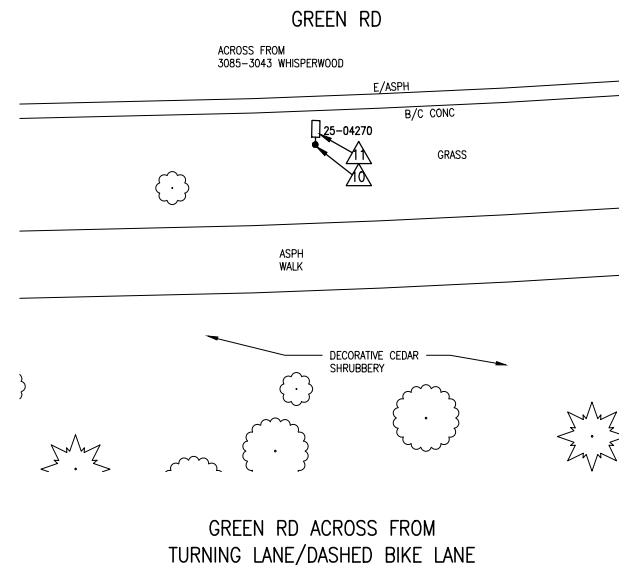
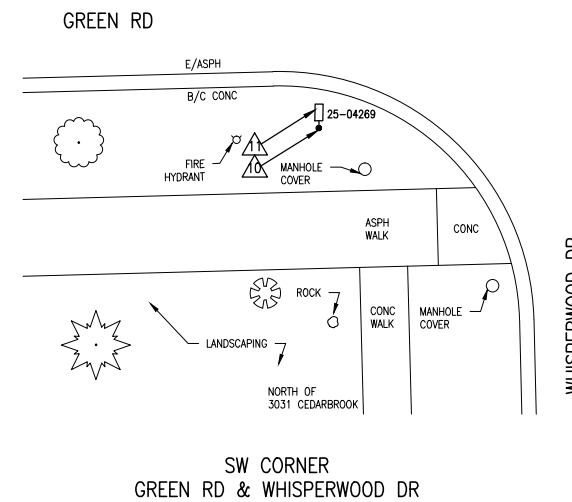

- REMOVAL KEY**
- 1 CONCRETE WALK, REMOVE
  - 2 BRICK PAVER WALK, REMOVE & SALVAGE
  - 3 PAVEMENT, REMOVE
  - 4 LIGHT POLE, REMOVE
  - 5 FOUNDATION, REMOVE
  - 6 FIXTURE, REMOVE
  - 7 FIXTURE, REMOVE & SALVAGE
  - 8 FOUNDATION, PROTECT
  - 9 HANDHOLE, REMOVE
  - 10 LIGHT POLE, REMOVE & SALVAGE
  - 11 LIGHT POLE, PROTECT

- CONSTRUCTION KEY**
- 1 CONCRETE WALK
  - 2 BRICK PAVER WALK, REINSTALL
  - 3 ADA RAMP
  - 4 CONCRETE PAVEMENT
  - 5 HMA PAVEMENT
  - 6 TOPSOIL, SEED & MULCH
  - 7 POLE FOUNDATION
  - 8 LIGHT POLE, LP1
  - 9 LIGHT POLE, LP2
  - 10 LIGHT POLE, LP3
  - 11 FIXTURE, REINSTALL
  - 12 FIXTURE, SL1
  - 13 FIXTURE, SL2
  - 14 FIXTURE, SL3
  - 15 HANDHOLE
  - 16 LIGHT POLE, REINSTALL



Know what's below.  
Call before you dig.

COPYRIGHT 2017 OHM ALL DRAWINGS AND WRITTEN MATERIALS APPEARING HEREIN CONSTITUTE THE ORIGINAL AND UNPUBLISHED WORK OF OHM AND THE SAME MAY NOT BE DUPLICATED, DISTRIBUTED, OR DISCLOSED WITHOUT PRIOR WRITTEN CONSENT OF OHM

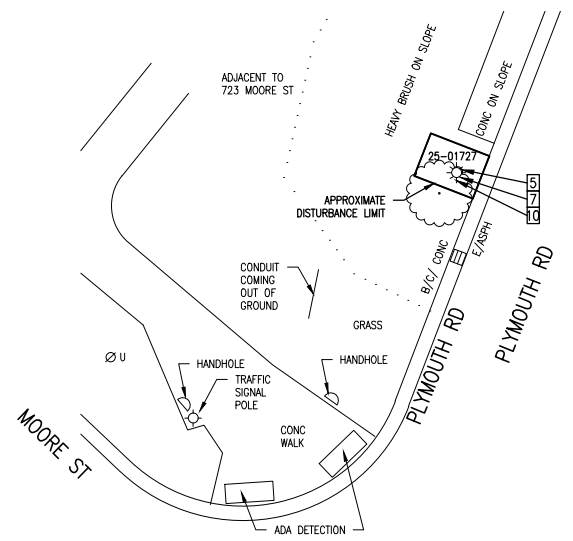

#1 - PLYMOUTH RD  
 NW CORNER AT MOORE ST

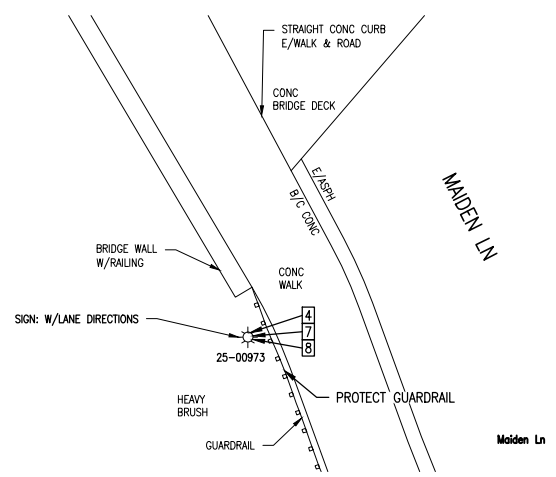

#2 - SOUTHWEST SIDE OF MAIDEN LN BRIDGE  
 SOUTH OF WALL

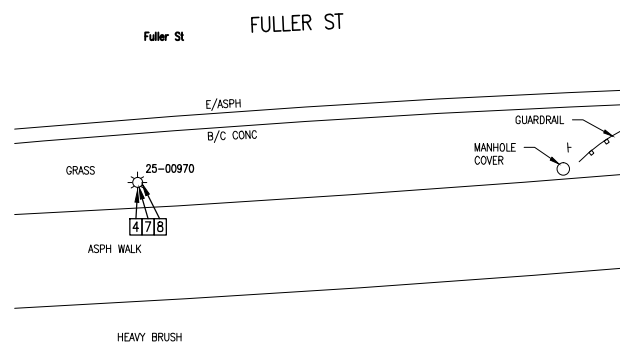

#3 - EB FULLER AT GORE WEST OF THE HURON RIVER

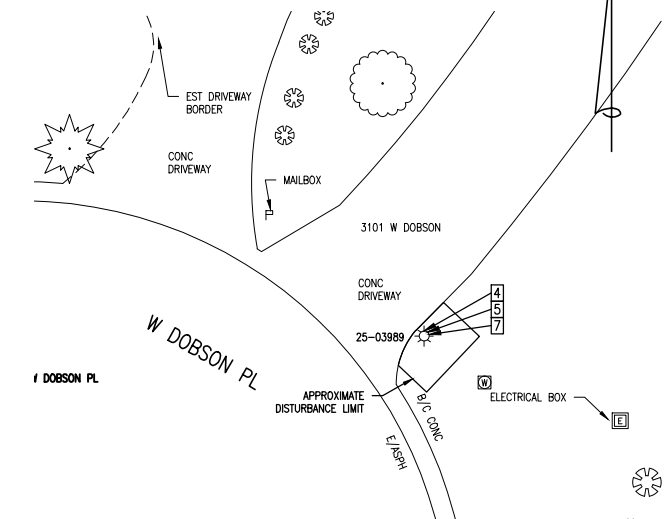

#4 - CUL-DE-SAC  
 WEST END OF W DOBSON PL

**REMOVAL KEY**

- 1 CONCRETE WALK, REMOVE
- 2 BRICK PAVER WALK, REMOVE & SALVAGE
- 3 PAVEMENT, REMOVE
- 4 LIGHT POLE, REMOVE
- 5 FOUNDATION, REMOVE
- 6 FIXTURE, REMOVE
- 7 FIXTURE, REMOVE & SALVAGE
- 8 FOUNDATION, PROTECT
- 9 HANDHOLE, REMOVE
- 10 LIGHT POLE, REMOVE & SALVAGE
- 11 LIGHT POLE, PROTECT

**CONSTRUCTION KEY**

- 1 CONCRETE WALK
- 2 BRICK PAVER WALK, REINSTALL
- 3 ADA RAMP
- 4 CONCRETE PAVEMENT
- 5 HMA PAVEMENT
- 6 TOPSOIL, SEED & MULCH
- 7 POLE FOUNDATION
- 8 LIGHT POLE, LP1
- 9 LIGHT POLE, LP2
- 10 LIGHT POLE, LP3
- 11 FIXTURE, REINSTALL
- 12 FIXTURE, SL1
- 13 FIXTURE, SL2
- 14 FIXTURE, SL3
- 15 HANDHOLE
- 16 LIGHT POLE, REINSTALL

**REMOVAL PLAN**

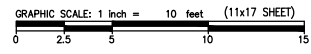

**QUANTITIES THIS SHEET**

TOTAL	UNIT	DESCRIPTION
2	Ea	Foundation, Rem
3	Ea	Light Pole, Rem
1	Ea	Light Pole, Rem and Salvage
2	Ea	Foundation, Light Pole
3	Ea	Light Pole, LP3
1	Ea	Light Pole, Reinstall
4	Ea	Fixture, Reinstall

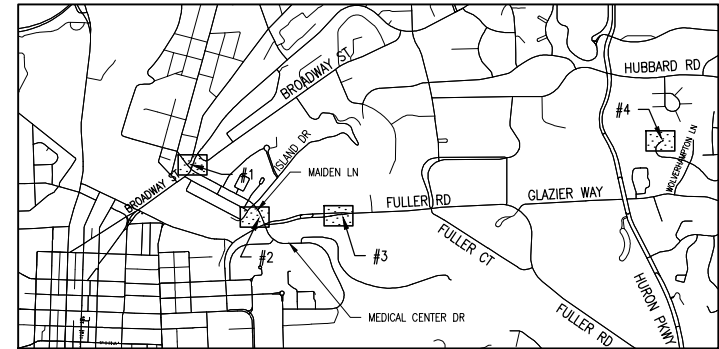

**KEY PLAN**  
 NOT TO SCALE

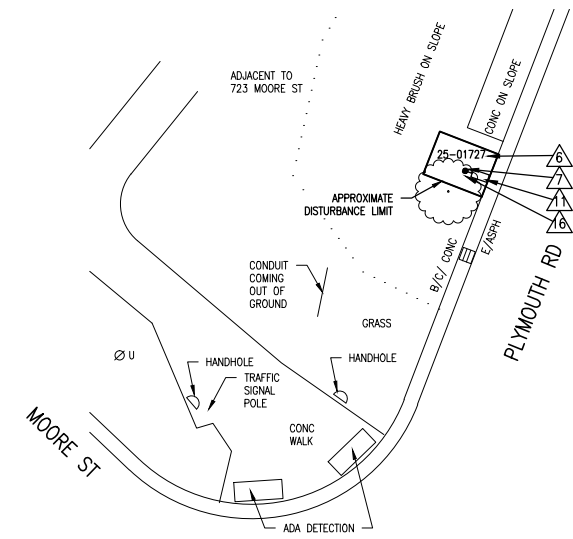

#1 - PLYMOUTH RD  
 NW CORNER AT MOORE ST

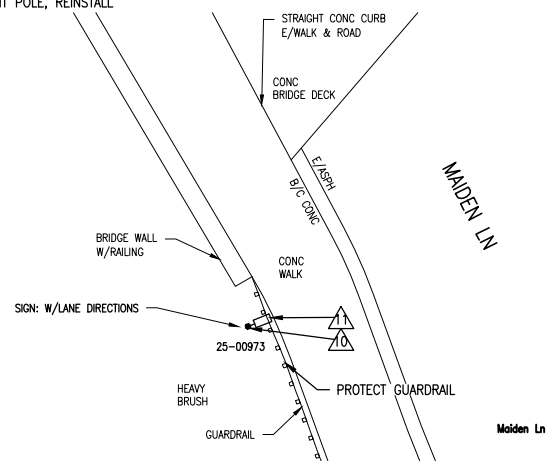

#2 - SOUTHWEST SIDE OF MAIDEN LN BRIDGE  
 SOUTH OF WALL

**CONSTRUCTION PLAN**

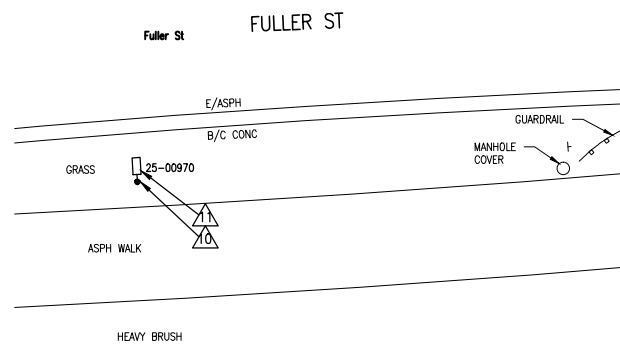
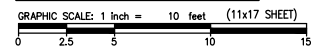

#3 - EB FULLER AT GORE WEST OF THE HURON RIVER

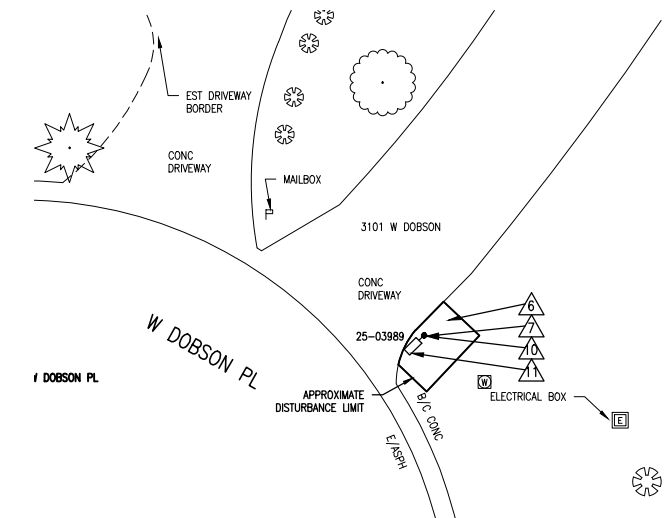

#4 - CUL-DE-SAC  
 WEST END OF W DOBSON PL



REVISIONS:  
 11-28-18 BID SET  
 12-14-18 ADDENDUM No. 1 REVISIONS

CITY OF ANN ARBOR  
 ITB NO. 4557 2019 STREET LIGHT REPLACEMENT  
 REMOVAL & CONSTRUCTION PLAN

DRAWING PATH: C:\Users\eham\appdata\local\temp\acPublish\_12512180\00CON\_04.dwg Dec 13, 2018 - 9:53am

COPYRIGHT 2017 OHM ALL DRAWINGS AND WRITTEN MATERIALS APPEARING HEREIN CONSTITUTE THE ORIGINAL AND UNPUBLISHED WORK OF OHM AND THE SAME MAY NOT BE DUPLICATED, DISTRIBUTED, OR DISCLOSED WITHOUT PRIOR WRITTEN CONSENT OF OHM

DRAWING PATH: C:\Users\eham\appdata\local\temp\acPublish\_12512180\00CON\_04.dwg Dec 13, 2018 - 9:53am

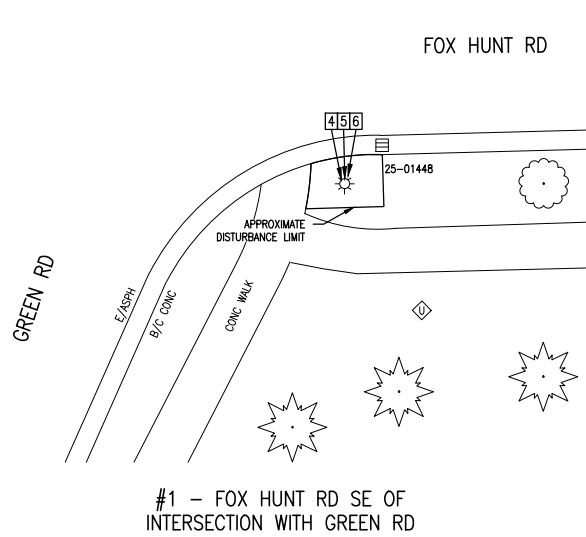

#1 - FOX HUNT RD SE OF INTERSECTION WITH GREEN RD

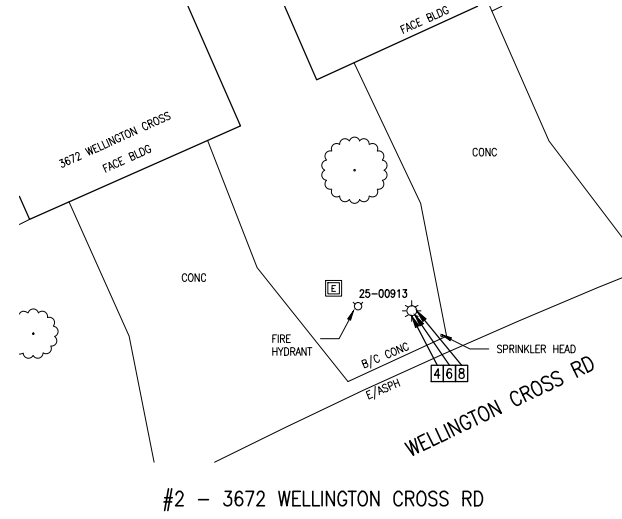

#2 - 3672 WELLINGTON CROSS RD

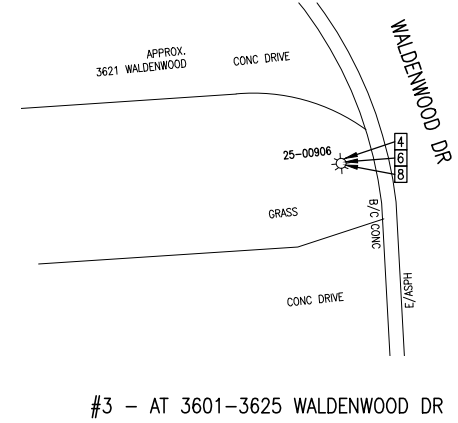

#3 - AT 3601-3625 WALDENWOOD DR

**REMOVAL PLAN**

GRAPHIC SCALE: 1 inch = 10 feet (11x17 SHEET)

**QUANTITIES THIS SHEET**

TOTAL	UNIT	DESCRIPTION
1	Ea	Foundation, Rem
3	Ea	Light Pole, Rem
1	Ea	Foundation, Light Pole
3	Ea	Light Pole, LP1
3	Ea	Fixture, SL1

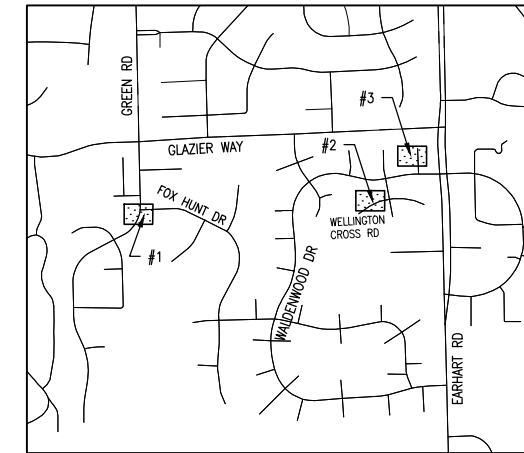

**KEY PLAN**  
NOT TO SCALE

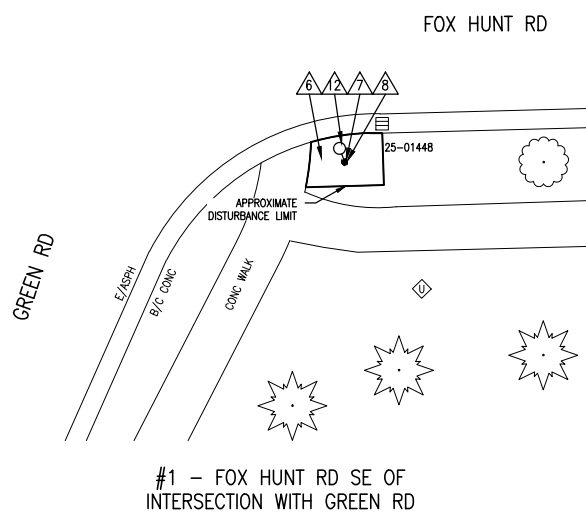

#1 - FOX HUNT RD SE OF INTERSECTION WITH GREEN RD

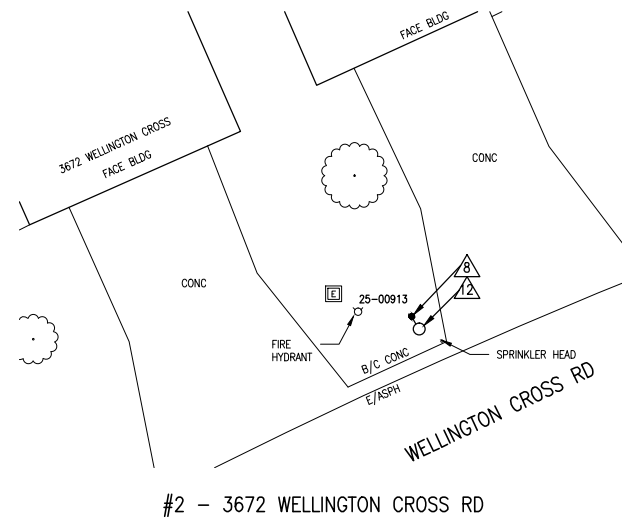

#2 - 3672 WELLINGTON CROSS RD

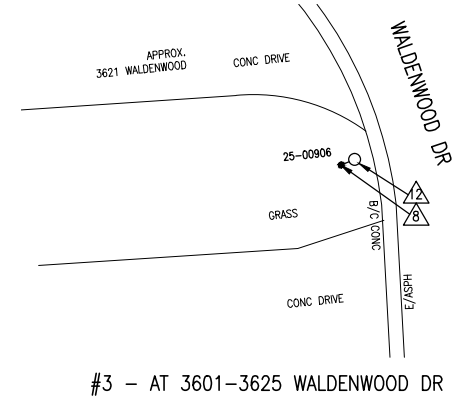

#3 - AT 3601-3625 WALDENWOOD DR

**CONSTRUCTION PLAN**

GRAPHIC SCALE: 1 inch = 10 feet (11x17 SHEET)

**REMOVAL KEY**

- 1 CONCRETE WALK, REMOVE
- 2 BRICK PAVER WALK, REMOVE & SALVAGE
- 3 PAVEMENT, REMOVE
- 4 LIGHT POLE, REMOVE
- 5 FOUNDATION, REMOVE
- 6 FIXTURE, REMOVE
- 7 FIXTURE, REMOVE & SALVAGE
- 8 FOUNDATION, PROTECT
- 9 HANDHOLE, REMOVE
- 10 LIGHT POLE, REMOVE & SALVAGE
- 11 LIGHT POLE, PROTECT

**CONSTRUCTION KEY**

- 1 CONCRETE WALK
- 2 BRICK PAVER WALK, REINSTALL
- 3 ADA RAMP
- 4 CONCRETE PAVEMENT
- 5 HMA PAVEMENT
- 6 TOPSOIL, SEED & MULCH
- 7 POLE FOUNDATION
- 8 LIGHT POLE, LP1
- 9 LIGHT POLE, LP2
- 10 LIGHT POLE, LP3
- 11 FIXTURE, REINSTALL
- 12 FIXTURE, SL1
- 13 FIXTURE, SL2
- 14 FIXTURE, SL3
- 15 HANDHOLE
- 16 LIGHT POLE, REINSTALL



Know what's below.  
Call before you dig.

COPYRIGHT 2017 OHM ALL DRAWINGS AND WRITTEN MATERIALS APPEARING HEREIN CONSTITUTE THE ORIGINAL AND UNPUBLISHED WORK OF OHM AND THE SAME MAY NOT BE DUPLICATED, DISTRIBUTED, OR DISCLOSED WITHOUT PRIOR WRITTEN CONSENT OF OHM