

CITY OF ANN ARBOR
INVITATION TO BID



STREET SURFACE TREATMENT PROJECT - FY2019

ITB No. 4530

Due Date: **Wednesday, May 16, 2018 at or before 2:00 p.m. (Local Time)**

**Public Services Area
Engineering Unit**

Issued By:

City of Ann Arbor
Procurement Unit
301 E. Huron Street
Ann Arbor, MI 48104

TABLE OF CONTENTS

| | |
|---|----------------------------|
| TABLE OF CONTENTS..... | TC-1 |
| NOTICE OF PRE-BID CONFERENCE..... | NP-1 |
| INSTRUCTIONS TO BIDDERS..... | IB-1 to 6 |
| INVITATION TO BID..... | ITB-1 to 3 |
| BID FORMS..... | BF-1 to 7 |
| CONTRACT..... | C-1 to 3 |
| BOND FORMS..... | B-1 to 2 |
| GENERAL CONDITIONS..... | GC-1 to 16 |
| STANDARD SPECIFICATIONS..... | SS-1 |
| DETAILED SPECIFICATIONS..... | (see page numbering below) |
| DS for General Conditions..... | DS-1 to 2 |
| DS for Project Supervision..... | DS-3 to 6 |
| DS for Certified Payroll Compliance and Reporting..... | DS-7 to 8 |
| DS for Resident Notification..... | DS-9 |
| DS for Materials and Supplies Certifications..... | DS-10 |
| DS for Vacuum Type Cleaning Equipment..... | DS-11 |
| DS for Project Schedule includes "Schedule of Streets"..... | DS-12 to 14 |
| DS for Maximum Unit Weight..... | DS-15 |
| DS for Soil Erosion and Sedimentation Control - Inlet Filter..... | DS-16 |
| DS for Hot Mix Asphalt Pavement Repair..... | DS-17 to 18 |
| DS for Micro-surfacing..... | DS-19 to 20 |
| DS for Chip Seal..... | DS-21 to 23 |
| DS for Slurry Seal..... | DS-24 to 25 |
| DS for Permanent Pavement Markings..... | DS-26 |
| DS for Maintenance of Traffic..... | DS-27 to 70 |
| DS for Minor Traffic Control..... | DS-71 to 74 |
| DS for No Parking Signs..... | DS-75 |
| APPENDIX..... | APDX-1 |
| Notices to Bidders | |
| Michigan Department of Transportation (MDOT) Special Provisions | |
| MDOT Supplemental Specifications | |
| Project Listing of Streets | |
| Project Log | |
| Project Location Maps | |

ATTACHMENTS

City of Ann Arbor Prevailing Wage Declaration of Compliance Form
City of Ann Arbor Living Wage Declaration of Compliance Form and Ordinance Poster
City of Ann Arbor Vendor Conflict of Interest Disclosure Form
City of Ann Arbor Non-Discrimination Declaration of Compliance Form and Ordinance Notice
MDOT Certified Payroll Forms

NOTICE OF PRE-BID CONFERENCE

The City will hold a pre-bid conference for this project on **Friday, May 4, 2018**, at **1:00 p.m.** in the **4th Floor Conference Room** of the Guy C. Larcom Building (City Hall), located at 301 East Huron Street, Ann Arbor, Michigan, 48104.

Attendance at this conference is highly recommended. City staff will answer administrative and technical questions regarding the project at this time. The pre-bid conference is only for informational purposes. Any answers furnished will not be official until verified in writing by the Financial Service Area, Procurement Unit. City staff will issue an addendum to affirm answers that change or substantially clarify the bid.

INSTRUCTIONS TO BIDDERS

General

Work to be done under this Contract is generally described through the detailed specifications and must be completed fully in accordance with the contract documents. All work to be done under this Contract is located in or near the City of Ann Arbor.

Any Bid which does not conform fully to these instructions may be rejected.

Preparation of Bids

Bids should be prepared providing a straight-forward, concise description of the Bidder's ability to meet the requirements of the ITB. Bids shall be written in ink or typewritten. No erasures are permitted. Mistakes may be crossed out and corrected and must be initialed and dated in ink by the person signing the Bid.

Bids must be submitted on the "Bid Forms" provided with each blank properly filled in. If forms are not fully completed it may disqualify the bid. No alternative bid will be considered unless alternative bids are specifically requested. If alternatives are requested, any deviation from the specification must be fully described, in detail on the "Alternate" section of Bid form.

Each person signing the Bid certifies that he/she is the person in the Bidder's firm/organization responsible for the decision as to the fees being offered in the Bid and has not and will not participated in any action contrary to the terms of this provision.

Questions or Clarification on ITB Specifications

All questions regarding this ITB shall be submitted via email. Emailed questions and inquires will be accepted from any and all prospective Bidders in accordance with the terms and conditions of the ITB.

All questions shall be due on or before **Tuesday, May 8, 2018, at 5:00pm** and should be addressed as follows:

Specification/Scope of Work questions emailed to **ddykman@a2gov.org**
Bid Process and Compliance questions emailed to **cspencer@a2gov.org**

Any error, omissions or discrepancies in the plans and specifications discovered by a prospective contractor and/or service provider shall be brought to the attention of **David Dykman** at **ddykman@a2gov.org** as quickly as possible after discovery. Further, the contractor and/or service provider shall not be allowed to take advantage of errors, omissions or discrepancies in the plans and specifications.

Addenda

If it becomes necessary to revise any part of the ITB, notice of the Addendum will be posted to

Michigan Inter-governmental Trade Network (MITN) www.mitn.info and/or City of Ann Arbor web site www.A2gov.org for all parties to download.

Each Bidder must in its Bid, to avoid any miscommunications, acknowledge all addenda which it has received, but the failure of a Bidder to receive, or acknowledge receipt of; any addenda shall not relieve the Bidder of the responsibility for complying with the terms thereof.

The City will not be bound by oral responses to inquiries or written responses other than written addenda.

Bid Submission

All Bids are due and must be delivered to the City of Ann Arbor Procurement Unit on or before **2:00 p.m., Wednesday, May 16, 2018, (Local Time)**. Bids submitted late or via oral, telephonic, telegraphic, electronic mail or facsimile **will not** be considered or accepted.

Each Bidder must submit one (1) original Bid and **two (2)** Bid copies in a sealed envelope clearly marked: **ITB No. 4530: Street Surface Treatment Project - FY2019**.

Bids must be addressed and delivered to:

City of Ann Arbor
Procurement Unit,
c/o Customer Services, 1st Floor
301 East Huron Street
Ann Arbor, MI 48107

All Bids received on or before the Due Date will be publicly opened and recorded immediately. No immediate decisions are rendered.

The following forms provided within this ITB Document must be included in submitted bids.

- **City of Ann Arbor Prevailing Wage Declaration of Compliance**
- **City of Ann Arbor Living Wage Ordinance Declaration of Compliance**
- **Vendor Conflict of Interest Disclosure Form**
- **City of Ann Arbor Non-Discrimination Ordinance Declaration of Compliance**

Bids that fail to provide these completed forms listed above upon bid opening will be rejected as non-responsive and will not be considered for award.

Hand delivered bids will be date/time stamped/signed by the Procurement Unit at the address above in order to be considered. Normal business hours are 9:00 a.m. to 3:00 p.m. Monday through Friday, excluding Holidays. The City will not be liable to any Bidder for any unforeseen circumstances, delivery or postal delays. Postmarking to the Due Date will not substitute for receipt of the Bid. Each Bidder is responsible for submission of their Bid.

Additional time for submission of bids past the stated due date and time will not be granted to a single Bidder; however, additional time may be granted to all Bidders when the City determines in its sole discretion that circumstances warrant it.

Award

The City intends to award a Contract(s) to the lowest responsible Bidder(s). On multi-divisional contracts, separate divisions may be awarded to separate Bidders. The City may also utilize alternatives offered in the Bid Forms, if any, to determine the lowest responsible Bidder on each division, and award multiple divisions to a single Bidder, so that the lowest total cost is achieved for the City. For unit price bids, the Contract will be awarded based upon the unit prices and the lump sum prices stated by the bidder for the work items specified in the bid documents, with consideration given to any alternates selected by the City. If the City determines that the unit price for any item is materially different for the work item bid than either other bidders or the general market, the City, in its sole discretion, in addition to any other right it may have, may reject the bid as not responsible or non-conforming.

The acceptability of major subcontractors will be considered in determining if a Bidder is responsible. In comparing Bids, the City will give consideration to alternate Bids for items listed in the bid forms. All key staff and subcontractors are subject to the approval by the City.

Official Documents

The City of Ann Arbor officially distributes bid documents from the Procurement Unit or through the Michigan Intergovernmental Trade Network (MITN). Copies of the bid documents obtained from any other source are not Official copies. Addenda and other bid information will only be posted to these official distribution sites. If you obtained City of Ann Arbor Bid documents from other sources, it is recommended that you register on www.MITN.info and obtain an official Bid. Bidders do not need to be shown on the plan holders list provided by MITN to be considered an official plan holder.

Bid Security

Each bid must be accompanied by a certified check, or Bid Bond by a surety licensed and authorized to do business within the State of Michigan, in the amount of 5% of the total of the bid price.

Withdrawal of Bids

After the time of opening, no Bid may be withdrawn for the period of ninety (90) days

Contract Time

Time is of the essence in the performance of the work under this Contract. The available time for work under this Contract is indicated on page C-2, Article III of the Contract. If these time requirements can not be met, the Bidder must stipulate on Bid Form Section 3 - Time Alternate its schedule for performance of the work. Consideration will be given to time in evaluating bids.

Liquidated Damages

A liquidated damages clause, as given on page C-2, Article III of the Contract, provides that the

Contractor shall pay the City as liquidated damages, and not as a penalty, a sum certain per day for each and every day that the Contractor may be in default of completion of the specified work, within the time(s) stated in the Contract, or written extensions.

Liquidated damages clauses, as given in the General Conditions, provide further that the City shall be entitled to impose and recover liquidated damages for breach of the obligations under Chapter 112 of the City Code.

The liquidated damages are for the non-quantifiable aspects of any of the previously identified events and do not cover actual damages that can be shown or quantified nor are they intended to preclude recovery of actual damages in addition to the recovery of liquidated damages.

Human Rights Information

All contractors proposing to do business with the City shall satisfy the contract compliance administrative policy adopted by the City Administrator in accordance with the Section 9:158 of the Ann Arbor City Code. Breach of the obligation not to discriminate as outlined in Section 5, beginning at page GC-3 shall be a material breach of the contract. Contractors are required to post a copy of Ann Arbor's Non-Discrimination Ordinance attached at all work locations where its employees provide services under a contract with the City.

Wage Requirements

Section 4, beginning at page GC-1, outlines the requirements for payment of prevailing wages and for payment of a "living wage" to employees providing service to the City under this contract. The successful bidder and its subcontractors must comply with all applicable requirements and provide proof of compliance.

Pursuant to Resolution R-16-469 all public improvement contractors are subject to prevailing wage and will be required to provide to the City payroll records sufficient to demonstrate compliance with the prevailing wage requirements. Use of the Prevailing Wage Form provided in the Appendix section or a City-approved equivalent will be required along with wage rate interviews.

For laborers whose wage level are subject to federal, state and/or local prevailing wage law the appropriate Davis-Bacon wage rate classification is identified based upon the work including within this contract. **The wage determination(s) current on the date 10 days before bids are due shall apply to this contract.** The U.S. Department of Labor (DOL) has provided explanations to assist with classification in the following resource link: www.wdol.gov.

For the purposes of this ITB the Construction Type of Highway will apply.

Conflict Of Interest Disclosure

The City of Ann Arbor Purchasing Policy requires that prospective Vendors complete a Conflict of Interest Disclosure form. A contract may not be awarded to the selected Vendor unless and until the Procurement Unit and the City Administrator have reviewed the Disclosure form and determined that no conflict exists under applicable federal, state, or local law or administrative

regulation. Not every relationship or situation disclosed on the Disclosure Form may be a disqualifying conflict. Depending on applicable law and regulations, some contracts may awarded on the recommendation of the City Administrator after full disclosure, where such action is allowed by law, if demonstrated competitive pricing exists and/or it is determined the award is in the best interest of the City. A copy of the Vendor Conflict of Interest Disclosure Form is attached.

Major Subcontractors

The Bidder shall identify on Bid Form Section 4 each major subcontractor it expects to engage for this Contract if the work to be subcontracted is 15% or more of the bid sum or over \$50,000, whichever is less. The Bidder also shall identify the work to be subcontracted to each major subcontractor. The Bidder shall not change or replace a subcontractor without approval by the City.

Debarment

Submission of a Bid in response to this ITB is certification that the Bidder is not currently debarred, suspended, proposed for debarment, and declared ineligible or voluntarily excluded from participation in this transaction by any State or Federal departments or agency. Submission is also agreement that the City will be notified of any changes in this status.

Disclosures

After bids are opened, all information in a submitter's bid is subjected to disclosure under the provisions of Michigan Public Act No. 442 of 1976, as amended (MCL 15.231 et seq.) known as the "Freedom of Information Act." The Freedom of Information Act also provides for the complete disclosure of contracts and attachments thereto except where specifically exempted.

Bid Protest

All Bid protests must be in writing and filed with the Purchasing Agent within five (5) business days of the award action. The bidder must clearly state the reasons for the protest. If a bidder contacts a City Service Area/Unit and indicates a desire to protest an award, the Service Area/Unit shall refer the bidder to the Purchasing Agent. The Purchasing Agent will provide the bidder with the appropriate instructions for filing the protest. The protest shall be reviewed by the City Administrator or designee whose decision shall be final.

Any inquiries or requests regarding this procurement should be only submitted in writing to the Designated City Contacts provided herein. Attempts by the Offeror to initiate contact with anyone other than the Designated City Contacts provided herein that the prospective Offeror believes can influence the procurement decision, e.g., Elected Officials, City Administrator, Selection Committee Members, Appointed Committee Members, etc., may lead to immediate elimination from further consideration.

Cost Liability

The City of Ann Arbor assumes no responsibility or liability for costs incurred by the Bidder prior to the execution of a contract with the City. By submitting a bid, a bidder agrees to bear all costs incurred or related to the preparation, submission and selection process for the bid.

Reservation of Rights

The City of Ann Arbor reserves the right to accept any bid or alternative bid proposed in whole or in part, to reject any or all bids or alternatives bids in whole or in part and to waive irregularity and/or informalities in any bid and to make the award in any manner deemed in the best interest of the City.

Idlefree Ordinance

The City of Ann Arbor adopted an idling reduction Ordinance that goes into effect July 1, 2017. The full text of the ordinance (including exemptions) can be found at: www.a2gov.org/idlefree.

Under the ordinance, No Operator of a Commercial Vehicle shall cause or permit the Commercial Vehicle to Idle:

- (a) For any period of time while the Commercial Vehicle is unoccupied; or
- (b) For more than 5 minutes in any 60-minute period while the Commercial Vehicle is occupied.

In addition, generators and other internal combustion engines are covered

- (1) Excluding Motor Vehicle engines, no internal combustion engine shall be operated except when it is providing power or electrical energy to equipment or a tool that is actively in use.

INVITATION TO BID

City of Ann Arbor
Guy C. Larcom Municipal Building
Ann Arbor, Michigan 48107

Ladies and Gentlemen:

The undersigned, as Bidder, declares that this Bid is made in good faith, without fraud or collusion with any person or persons bidding on the same Contract; that this Bidder has carefully read and examined the bid documents, including City Nondiscrimination requirements and Declaration of Compliance Form, Living Wage requirements and Declaration of Compliance Form, Prevailing Wage requirements and Declaration of Compliance Form, Vendor Conflict of Interest Form, Notice of Pre-Bid Conference, Instructions to Bidders, Bid, Bid Forms, Contract, Bond Forms, General Conditions, Standard Specifications, Detailed Specifications, all Addenda, and the Plans (if applicable) and understands them. The Bidder declares that it conducted a full investigation at the site and of the work proposed and is fully informed as to the nature of the work and the conditions relating to the work's performance. The Bidder also declares that it has extensive experience in successfully completing projects similar to this one.

The Bidder acknowledges that it has not received or relied upon any representations or warrants of any nature whatsoever from the City of Ann Arbor, its agents or employees, and that this Bid is based solely upon the Bidder's own independent business judgment.

The undersigned proposes to perform all work shown on the plans or described in the bid documents, including any addenda issued, and to furnish all necessary machinery, tools, apparatus, and other means of construction to do all the work, furnish all the materials, and complete the work in strict accordance with all terms of the Contract of which this Bid is one part.

In accordance with these bid documents, and Addenda numbered _____, the undersigned, as Bidder, proposes to perform at the sites in and/or around Ann Arbor, Michigan, all the work included herein for the amounts set forth in the Bid Forms.

The Bidder declares that it has become fully familiar with the liquidated damage clauses for completion times and for compliance with City Code Chapter 112, understands and agrees that the liquidated damages are for the non-quantifiable aspects of non-compliance and do not cover actual damages that may be shown and agrees that if awarded the Contract, all liquidated damage clauses form part of the Contract.

The Bidder declares that it has become fully familiar with the provisions of Chapter 14, Section 1:320 (Prevailing wages) and Chapter 23 (Living Wage) of the Code of the City of Ann Arbor and that it understands and agrees to comply, to the extent applicable to employees providing services to the City under this Contract, with the wage and reporting requirements stated in the City Code provisions cited. Bidder certifies that the statements contained in the City Prevailing Wage and Living Wage Declaration of Compliance Forms are true and correct. Bidder further agrees that the cited provisions of Chapter 14 and Chapter 23 form a part of this Contract.

The Bidder declares that it has become familiar with the City Conflict of Interest Disclosure Form and certifies that the statement contained therein is true and correct.

The Bidder encloses a certified check or Bid Bond in the amount of 5% of the total of the Bid Price. The Bidder agrees both to contract for the work and to furnish the necessary Bonds and insurance documentation within 10 days after being notified of the acceptance of the Bid.

If this Bid is accepted by the City and the Bidder fails to contract and furnish the required Bonds and insurance documentation within 10 days after being notified of the acceptance of this Bid, then the Bidder shall be considered to have abandoned the Contract and the certified check or Bid Bond accompanying this Bid shall become due and payable to the City.

If the Bidder enters into the Contract in accordance with this Bid, or if this Bid is rejected, then the accompanying check or Bid Bond shall be returned to the Bidder.

In submitting this Bid, it is understood that the right is reserved by the City to accept any Bid, to reject any or all Bids, to waive irregularities and/or informalities in any Bid, and to make the award in any manner the City believes to be in its best interest.

SIGNED THIS _____ DAY OF _____, 2018.

Bidder's Name

Authorized Signature of Bidder

Official Address

(Print Name of Signer Above)

Telephone Number

Email Address for Award Notice

LEGAL STATUS OF BIDDER

(The Bidder shall fill out the appropriate form and strike out the other three.)

Bidder declares that it is:

* A corporation organized and doing business under the laws of the State of _____, for whom _____, bearing the office title of _____, whose signature is affixed to this Bid, is authorized to execute contracts.

NOTE: If not incorporated in Michigan, please attach the corporation's Certificate of Authority

• A limited liability company doing business under the laws of the State of _____, whom _____ bearing the title of _____ whose signature is affixed to this proposal, is authorized to execute contract on behalf of the LLC.

* A partnership, organized under the laws of the state of _____ and filed in the county of _____, whose members are (list all members and the street and mailing address of each) (attach separate sheet if necessary):

* An individual, whose signature with address, is affixed to this Bid: _____
(initial here)

Authorized Official

_____ **Date** _____, 2018_

(Print) Name _____ Title _____

Company: _____

Address: _____

Contact Phone () _____ Fax () _____

Email _____

BID FORM

Section 1 - Schedule of Prices

Street Surface Treatments - FY2019
File No. 2018-020
Bid No. 4530

| <u>Line No.</u> | <u>Item No.</u> | <u>Item Description</u> | <u>Unit</u> | <u>Estimated Quantity</u> | <u>Unit Price</u> | <u>Total Price</u> |
|-----------------|-----------------|---|-------------|---------------------------|-------------------|--------------------|
| 10 | 1047051 | _General Conditions, Max \$85,000.00 | LSUM | 1.00 | \$ _____ | \$ _____ |
| 20 | 1047051 | _Project Supervision, Max \$50,000.00 | LSUM | 1.00 | \$ _____ | \$ _____ |
| 30 | 1047051 | _Certified Payroll Compliance and Reporting | LSUM | 1.00 | \$ _____ | \$ _____ |
| 40 | 1047051 | _Resident Notification | LSUM | 1.00 | \$ _____ | \$ _____ |
| 50 | 2080020 | Erosion Control, Inlet Protection, Fabric Drop | Ea | 135.00 | \$ _____ | \$ _____ |
| 60 | 2090001 | Project Cleanup | LSUM | 1.00 | \$ _____ | \$ _____ |
| 70 | 5017011 | _Cold Milling HMA Surface, Modified | Syd | 3,882.00 | \$ _____ | \$ _____ |
| 80 | 5017031 | _Hand Patching, Modified, Major Streets | Ton | 377.00 | \$ _____ | \$ _____ |
| 90 | 5017031 | _Hand Patching, Modified, Minor (Local) Streets | Ton | 222.00 | \$ _____ | \$ _____ |
| 100 | 5040005 | Micro-Surface, Rutfilling | Ton | 100.00 | \$ _____ | \$ _____ |
| 110 | 5047011 | _Micro-Surface, Single Course | Syd | 53,357.24 | \$ _____ | \$ _____ |
| 120 | 5057011 | _Seal, Single Chip, Modified | Syd | 82,948.00 | \$ _____ | \$ _____ |
| 130 | 5067011 | _Seal, Slurry, Modified | Syd | 106,551.00 | \$ _____ | \$ _____ |
| 140 | 8110049 | Pavt Mrkg, Ovly Cold Plastic, Direction Arrow Sym, Bike | Ea | 1.00 | \$ _____ | \$ _____ |
| 150 | 8110058 | Pavt Mrkg, Ovly Cold Plastic, Bike, Small Sym | Ea | 1.00 | \$ _____ | \$ _____ |
| 160 | 8110195 | Pavt Mrkg, Thermopl, 4 inch, White | Ft | 5,400.00 | \$ _____ | \$ _____ |
| 170 | 8110196 | Pavt Mrkg, Thermopl, 4 inch, Yellow | Ft | 14,400.00 | \$ _____ | \$ _____ |
| 180 | 8110197 | Pavt Mrkg, Thermopl, 6 inch, Crosswalk | Ft | 500.00 | \$ _____ | \$ _____ |
| 190 | 8110198 | Pavt Mrkg, Thermopl, 6 inch, White | Ft | 2,000.00 | \$ _____ | \$ _____ |
| 200 | 8110214 | Pavt Mrkg, Thermopl, 12 inch, Crosswalk | Ft | 850.00 | \$ _____ | \$ _____ |
| 210 | 8110212 | Pavt Mrkg, Thermopl, 12 inch, Cross Hatching, White | Ft | 120.00 | \$ _____ | \$ _____ |

TOTAL THIS PAGE \$ _____

BID FORM

Section 1 - Schedule of Prices

Street Surface Treatments - FY2019

File No. 2018-020

Bid No. 4530

| <u>Line No.</u> | <u>Item No.</u> | <u>Item Description</u> | <u>Unit</u> | <u>Estimated Quantity</u> | <u>Unit Price</u> | <u>Total Price</u> |
|-----------------|-----------------|--|-------------|---------------------------|-------------------|--------------------|
| 220 | 8110213 | Pavt Mrkg, Thermopl, 12 inch, Cross Hatching, Yellow | Ft | 1,086.00 | \$ _____ | \$ _____ |
| 230 | 8110218 | Pavt Mrkg, Thermopl, 24 inch, Stop Bar | Ft | 275.00 | \$ _____ | \$ _____ |
| 240 | 8110343 | Rem Spec Mrkg | Sft | 1,025.00 | \$ _____ | \$ _____ |
| 250 | 8117050 | _Pavt Mrkg, Thermopl, Lt Turn Arrow Sym | Ea | 16.00 | \$ _____ | \$ _____ |
| 260 | 8117050 | _Pavt Mrkg, Thermopl, Rt Turn Arrow Sym | Ea | 3.00 | \$ _____ | \$ _____ |
| 270 | 8117050 | _Pavt Mrkg, Thermopl, Thru Arrow Sym | Ea | 2.00 | \$ _____ | \$ _____ |
| 280 | 8117050 | _Pavt Mrkg, Thermopl, Only | Ea | 12.00 | \$ _____ | \$ _____ |
| 290 | 8120012 | Barricade, Type III, High Intensity, Double Sided, Lighted, Furn | Ea | 82.00 | \$ _____ | \$ _____ |
| 300 | 8120013 | Barricade, Type III, High Intensity, Double Sided, Lighted, Oper | Ea | 82.00 | \$ _____ | \$ _____ |
| 310 | 8120030 | Channelizing Device, 42 inch, Furn | Ea | 703.00 | \$ _____ | \$ _____ |
| 320 | 8120031 | Channelizing Device, 42 inch, Oper | Ea | 703.00 | \$ _____ | \$ _____ |
| 330 | 8120140 | Lighted Arrow, Type C, Furn | Ea | 14.00 | \$ _____ | \$ _____ |
| 340 | 8120141 | Lighted Arrow, Type C, Oper | Ea | 14.00 | \$ _____ | \$ _____ |
| 350 | 8120210 | Pavt Mrkg, Longit, 6 inch or Less Width, Rem | Ft | 21,800.00 | \$ _____ | \$ _____ |
| 360 | 8120211 | Pavt Mrkg, Longit, Greater than 6 inch Width, Rem | Ft | 2,331.00 | \$ _____ | \$ _____ |
| 370 | 8120235 | Pavt Mrkg, Wet Retrlec, Type NR, Paint, 4 inch, White, Temp | Ft | 5,400.00 | \$ _____ | \$ _____ |
| 380 | 8120236 | Pavt Mrkg, Wet Retrlec, Type NR, Paint, 4 inch, Yellow, Temp | Ft | 14,400.00 | \$ _____ | \$ _____ |
| 390 | 8120250 | Plastic Drum, High Intensity, Furn | Ea | 135.00 | \$ _____ | \$ _____ |
| 400 | 8120251 | Plastic Drum, High Intensity, Oper | Ea | 135.00 | \$ _____ | \$ _____ |
| 410 | 8120280 | Raised Pavt Marker, Temp, Type 1, White, Monodirectional | Ea | 108.00 | \$ _____ | \$ _____ |
| 420 | 8120281 | Raised Pavt Marker, Temp, Type 1, Yellow, Bidirectional | Ea | 288.00 | \$ _____ | \$ _____ |
| TOTAL THIS PAGE | | | | | | \$ _____ |

BID FORM

Section 1 - Schedule of Prices

Street Surface Treatments - FY2019
 File No. 2018-020
 Bid No. 4530

| <u>Line No.</u> | <u>Item No.</u> | <u>Item Description</u> | <u>Unit</u> | <u>Estimated Quantity</u> | <u>Unit Price</u> | <u>Total Price</u> |
|-----------------------|-----------------|--|-------------|---------------------------|-------------------|--------------------|
| 430 | 8120310 | Sign Cover | Ea | 75.00 | \$ _____ | \$ _____ |
| 440 | 8120330 | Sign, Portable, Changeable Message, Furn | Ea | 6.00 | \$ _____ | \$ _____ |
| 450 | 8120331 | Sign, Portable, Changeable Message, Oper | Ea | 15.00 | \$ _____ | \$ _____ |
| 460 | 8120350 | Sign, Type B, Temp, Prismatic, Furn | Sft | 2,972.00 | \$ _____ | \$ _____ |
| 470 | 8120351 | Sign, Type B, Temp, Prismatic, Oper | Sft | 2,972.00 | \$ _____ | \$ _____ |
| 480 | 8120370 | Traf Regulator Control | LSUM | 1.00 | \$ _____ | \$ _____ |
| 490 | 8127050 | _No Parking Sign | Ea | 360.00 | \$ _____ | \$ _____ |
| 500 | 8127050 | _Pedestrian Type II Barricade, Temp | Ea | 20.00 | \$ _____ | \$ _____ |
| 510 | 8127051 | _Minor Traffic Control, Max \$70,000.00 | LSUM | 1.00 | \$ _____ | \$ _____ |
| TOTAL THIS PAGE | | | | | | \$ _____ |
| TOTAL FROM PAGE BF-1 | | | | | | \$ _____ |
| TOTAL FROM PAGE BF-2 | | | | | | \$ _____ |
| TOTAL BASE BID | | | | | | \$ _____ |

BID FORM

Section 2 - Material and Equipment Alternates

The Base Bid proposal price shall include materials and equipment selected from the designated items and manufacturers listed in the bidding documents. This is done to establish uniformity in bidding and to establish standards of quality for the items named.

If the Contractor wishes to quote alternate items for consideration by the City, it may do so under this Section. A complete description of the item and the proposed price differential must be provided. Unless approved at the time of award, substitutions where items are specifically named will be considered only as a negotiated change in Contract Sum.

| <u>Item Number</u> | <u>Description</u> | <u>Add/Deduct Amount</u> |
|--------------------|--------------------|--------------------------|
|--------------------|--------------------|--------------------------|

If the Bidder does not suggest any material or equipment alternate, the Bidder **MUST** complete the following statement:

For the work outlined in this request for bid, the bidder does NOT propose any material or equipment alternate under the Contract.

Signature of Authorized Representative of Bidder _____ Date _____

BID FORM

Section 3 - Time Alternate

If the Bidder takes exception to the time stipulated in Article III of the Contract, Time of Completion, page C-2, it is requested to stipulate below its proposed time for performance of the work. Consideration will be given to time in evaluating bids.

If the Bidder does not suggest any time alternate, the Bidder **MUST** complete the following statement:

For the work outlined in this request for bid, the bidder does NOT propose any time alternate under the Contract.

Signature of Authorized Representative of Bidder _____ Date

BID FORM

Section 4 - Major Subcontractors

For purposes of this Contract, a Subcontractor is anyone (other than the Contractor) who performs work (other than or in addition to the furnishing of materials, plans or equipment) at or about the construction site, directly or indirectly for or on behalf of the Contractor (and whether or not in privity of Contract with the Contractor), but shall not include any individual who furnishes merely the individual's own personal labor or services.

Contractor agrees that all subcontracts entered into by the Contractor shall contain similar wage provision to Section 4 of the General Conditions covering subcontractor's employees who perform work on this contract.

For the work outlined in these documents the Bidder expects to engage the following major subcontractors to perform the work identified:

| <u>Subcontractor (Name and Address)</u> | <u>Work</u> | <u>Amount</u> |
|---|-------------|---------------|
|---|-------------|---------------|

If the Bidder does not expect to engage any major subcontractor, the Bidder **MUST** complete the following statement:

For the work outlined in this request for bid, the bidder does NOT expect to engage any major subcontractor to perform work under the Contract.

Signature of Authorized Representative of Bidder _____ Date _____

CONTRACT

THIS AGREEMENT is made on the _____ day of _____, 201____, between the CITY OF ANN ARBOR, a Michigan Municipal Corporation, 301 East Huron Street, Ann Arbor, Michigan 48104 (“City”) and _____ (“Contractor”)

(An individual/partnership/corporation, include state of incorporation)

(Address)

Based upon the mutual promises below, the Contractor and the City agree as follows:

ARTICLE I - Scope of Work

The Contractor agrees to furnish all of the materials, equipment and labor necessary; and to abide by all the duties and responsibilities applicable to it for the project titled “**Street Surface Treatment Project – FY2019**” in accordance with the requirements and provisions of the following documents, including all written modifications incorporated into any of the documents, which are incorporated as part of this Contract:

| | |
|--|-------------------------|
| Living Wage and Non-Discrimination Ordinances -Declaration of Compliance Forms (if applicable) | Bonds |
| Vendor Conflict of Interest Form | General Conditions |
| Prevailing Wage Declaration of Compliance Form (if applicable) | Standard Specifications |
| Bid Forms | Detailed Specifications |
| Contract and Exhibits | Plans |
| | Addenda |

ARTICLE II - Definitions

Administering Service Area/Unit means **Public Services Unit / Engineering Unit**

Project means **Street Surface Treatment Project – FY2019; ITB No. 4530**

ARTICLE III - Time of Completion

- (A) The work to be completed under this Contract shall begin immediately on the date specified in the Notice to Proceed issued by the City.
- (B) The entire work for this Contract shall be completed in accordance with the scheduling requirements outlined in the “Detailed Specification for Project Schedule” found on page DS-1 of the Contract Documents.
- (C) Failure to complete all the work within the time specified above, including any extension granted in writing by the Supervising Professional, shall obligate the Contractor to pay the City, as liquidated damages and not as a penalty, the amount(s) specified in the “Detailed Specification for Project Schedule” found on page DS-1 of the Contract Documents for each calendar day of delay in the completion of all the work. If any liquidated damages are unpaid by the Contractor, the City shall be entitled to deduct these unpaid liquidated damages from the monies due the Contractor.

The liquidated damages are for the non-quantifiable aspects of any of the previously identified events and do not cover actual damages that can be shown

or quantified nor are they intended to preclude recovery of actual damages in addition to the recovery of liquidated damages.

- (D) The term of this Contract shall extend until June 30, 2019, or until satisfactory performance of all services have been performed, whichever occurs first. Subject to the availability of funding, the Contract may be extended for one one-year term, subject to the same terms and conditions, including unit prices, in the original Contract and subject to agreement by the City and the Contractor. Between January 1 and March 31, 2018, the City may provide a written request for the one year extension to the Contractor, after which the Contractor shall have 30 days to respond in writing that it agrees to the one year extension. Failure to respond may result in the Contract being reissued for bid.

ARTICLE IV - The Contract Sum

- (A) The City shall pay to the Contractor for the performance of the Contract, the unit prices as given in the Bid Form for the estimated bid total of:

_____ Dollars (\$_____)

- (B) The amount paid shall be equitably adjusted to cover changes in the work ordered by the Supervising Professional but not required by the Contract Documents. Increases or decreases shall be determined only by written agreement between the City and Contractor.

ARTICLE V - Assignment

This Contract may not be assigned or subcontracted any portion of any right or obligation under this contract without the written consent of the City. Notwithstanding any consent by the City to any assignment, Contractor shall at all times remain bound to all warranties, certifications, indemnifications, promises and performances, however described, as are required of it under this contract unless specifically released from the requirement, in writing, by the City.

ARTICLE VI - Choice of Law

This Contract shall be construed, governed, and enforced in accordance with the laws of the State of Michigan. By executing this agreement, the Contractor and the City agree to venue in a court of appropriate jurisdiction sitting within Washtenaw County for purposes of any action arising under this Contract. The parties stipulate that the venue referenced in this Contract is for convenience and waive any claim of non-convenience.

Whenever possible, each provision of the Contract will be interpreted in a manner as to be effective and valid under applicable law. The prohibition or invalidity, under applicable law, of any provision will not invalidate the remainder of the Contract.

ARTICLE VII - Relationship of the Parties

The parties of the Contract agree that it is not a Contract of employment but is a Contract to accomplish a specific result. Contractor is an independent Contractor performing services for the City. Nothing contained in this Contract shall be deemed to constitute any other relationship between the City and the Contractor.

Contractor certifies that it has no personal or financial interest in the project other than the compensation it is to receive under the Contract. Contractor certifies that it is not, and shall not become, overdue or in default to the City for any Contract, debt, or any other obligation to the City including real or personal property taxes. City shall have the right to set off any such debt against

compensation awarded for services under this agreement.

ARTICLE VIII - Notice

All notices given under this Contract shall be in writing, and shall be by personal delivery or by certified mail with return receipt requested to the parties at their respective addresses as specified in the Contract Documents or other address the Contractor may specify in writing. Notice will be deemed given on the date when one of the following first occur: (1) the date of actual receipt; or (2) three days after mailing certified U.S. mail.

ARTICLE IX - Indemnification

To the fullest extent permitted by law, Contractor shall indemnify, defend and hold harmless the City, its officers, employees and agents harmless from all suits, claims, judgments and expenses including attorney’s fees resulting or alleged to result, in whole or in part, from any act or omission, which is in any way connected or associated with this Contract, by the Contractor or anyone acting on the Contractor’s behalf under this Contract. Contractor shall not be responsible to indemnify the City for losses or damages caused by or resulting from the City’s sole negligence. The provisions of this Article shall survive the expiration or earlier termination of this contract for any reason.

ARTICLE X - Entire Agreement

This Contract represents the entire understanding between the City and the Contractor and it supersedes all prior representations, negotiations, agreements, or understandings whether written or oral. Neither party has relied on any prior representations in entering into this Contract. No terms or conditions of either party’s invoice, purchase order or other administrative document shall modify the terms and conditions of this Contract, regardless of the other party’s failure to object to such form. This Contract shall be binding on and shall inure to the benefit of the parties to this Contract and their permitted successors and permitted assigns and nothing in this Contract, express or implied, is intended to or shall confer on any other person or entity any legal or equitable right, benefit, or remedy of any nature whatsoever under or by reason of this Contract. This Contract may be altered, amended or modified only by written amendment signed by the City and the Contractor.

FOR CONTRACTOR

By _____

Its: _____

FOR THE CITY OF ANN ARBOR

By _____
Christopher Taylor, Mayor

By _____
Jacqueline Beaudry, City Clerk

Approved as to substance

By _____
Howard S. Lazarus, City Administrator

By _____
Craig Hupy, Public Services Area
Administrator

Approved as to form and content

By _____
Stephen K. Postema, City Attorney

PERFORMANCE BOND

- (1) _____ (referred to as "Principal"), and _____, a corporation duly authorized to do business in the State of Michigan (referred to as "Surety"), are bound to the City of Ann Arbor, Michigan (referred to as "City"), for \$ _____, the payment of which Principal and Surety bind themselves, their heirs, executors, administrators, successors and assigns, jointly and severally, by this bond.
- (2) The Principal has entered a written Contract with the City dated _____, 201____, for: _____ and this bond is given for that Contract in compliance with Act No. 213 of the Michigan Public Acts of 1963, as amended, being MCL 129.201 et seq.
- (3) Whenever the Principal is declared by the City to be in default under the Contract, the Surety may promptly remedy the default or shall promptly:
- (a) complete the Contract in accordance with its terms and conditions; or
 - (b) obtain a bid or bids for submission to the City for completing the Contract in accordance with its terms and conditions, and upon determination by Surety of the lowest responsible bidder, arrange for a Contract between such bidder and the City, and make available, as work progresses, sufficient funds to pay the cost of completion less the balance of the Contract price; but not exceeding, including other costs and damages for which Surety may be liable hereunder, the amount set forth in paragraph 1.
- (4) Surety shall have no obligation to the City if the Principal fully and promptly performs under the Contract.
- (5) Surety agrees that no change, extension of time, alteration or addition to the terms of the Contract or to the work to be performed thereunder, or the specifications accompanying it shall in any way affect its obligations on this bond, and waives notice of any such change, extension of time, alteration or addition to the terms of the Contract or to the work, or to the specifications.

SIGNED AND SEALED this _____ day of _____, 2018.

(Name of Surety Company)
By _____
(Signature)
Its _____
(Title of Office)

(Name of Principal)
By _____
(Signature)
Its _____
(Title of Office)

Approved as to form:

Name and address of agent:

Stephen K. Postema, City Attorney

LABOR AND MATERIAL BOND

- (1) _____
of _____ (referred to as "Principal"), and _____, a corporation duly authorized to do business in the State of Michigan, (referred to as "Surety"), are bound to the City of Ann Arbor, Michigan (referred to as "City"), for the use and benefit of claimants as defined in Act 213 of Michigan Public Acts of 1963, as amended, being MCL 129.201 et seq., in the amount of \$ _____, for the payment of which Principal and Surety bind themselves, their heirs, executors, administrators, successors and assigns, jointly and severally, by this bond.
- (2) The Principal has entered a written Contract with the City, dated _____, 201_, for _____; and this bond is given for that Contract in compliance with Act No. 213 of the Michigan Public Acts of 1963 as amended;
- (3) If the Principal fails to promptly and fully repay claimants for labor and material reasonably required under the Contract, the Surety shall pay those claimants.
- (4) Surety's obligations shall not exceed the amount stated in paragraph 1, and Surety shall have no obligation if the Principal promptly and fully pays the claimants.

SIGNED AND SEALED this _____ day of _____, 201_

(Name of Surety Company)
By _____
(Signature)
Its _____
(Title of Office)

(Name of Principal)
By _____
(Signature)
Its _____
(Title of Office)

Approved as to form:

Name and address of agent:

Stephen K. Postema, City Attorney

GENERAL CONDITIONS

Section 1 - Execution, Correlation and Intent of Documents

The contract documents shall be signed in 2 copies by the City and the Contractor.

The contract documents are complementary and what is called for by any one shall be binding. The intention of the documents is to include all labor and materials, equipment and transportation necessary for the proper execution of the work. Materials or work described in words which so applied have a well-known technical or trade meaning have the meaning of those recognized standards.

In case of a conflict among the contract documents listed below in any requirement(s), the requirement(s) of the document listed first shall prevail over any conflicting requirement(s) of a document listed later.

(1) Addenda in reverse chronological order; (2) Detailed Specifications; (3) Standard Specifications; (4) Plans; (5) General Conditions; (6) Contract; (7) Bid Forms; (8) Bond Forms; (9) Bid.

Section 2 - Order of Completion

The Contractor shall submit with each invoice, and at other times reasonably requested by the Supervising Professional, schedules showing the order in which the Contractor proposes to carry on the work. They shall include the dates at which the Contractor will start the several parts of the work, the estimated dates of completion of the several parts, and important milestones within the several parts.

Section 3 - Familiarity with Work

The Bidder or its representative shall make personal investigations of the site of the work and of existing structures and shall determine to its own satisfaction the conditions to be encountered, the nature of the ground, the difficulties involved, and all other factors affecting the work proposed under this Contract. The Bidder to whom this Contract is awarded will not be entitled to any additional compensation unless conditions are clearly different from those which could reasonably have been anticipated by a person making diligent and thorough investigation of the site.

The Bidder shall immediately notify the City upon discovery, and in every case prior to submitting its Bid, of every error or omission in the bidding documents that would be identified by a reasonably competent, diligent Bidder. In no case will a Bidder be allowed the benefit of extra compensation or time to complete the work under this Contract for extra expenses or time spent as a result of the error or omission.

Section 4 - Wage Requirements

Under this Contract, the Contractor shall conform to Chapter 14 of Title I of the Code of the City of Ann Arbor as amended; which in part states "...that all craftsmen, mechanics and laborers employed directly on the site in connection with said improvements, including said employees of subcontractors, shall receive the prevailing wage for the corresponding classes of craftsmen, mechanics and laborers, as determined by statistics for the Ann Arbor area compiled by the United States Department of Labor. At the request of the City, any contractor or subcontractor shall provide satisfactory proof of compliance with the contract provisions required by the Section.

Pursuant to Resolution R-16-469 all public improvement contractors are subject to prevailing wage and will be required to provide to the City payroll records sufficient to demonstrate compliance with the prevailing wage requirements. A sample Prevailing Wage Form is provided in the Appendix herein for reference as to what will be expected from contractors. Use of the Prevailing Wage Form provided in the Appendix section or a City-approved equivalent will be required along with wage rate interviews.

Where the Contract and the Ann Arbor City Ordinance are silent as to definitions of terms required in determining contract compliance with regard to prevailing wages, the definitions provided in the Davis-Bacon Act as amended (40 U.S.C. 278-a to 276-a-7) for the terms shall be used.

If the Contractor is a "covered employer" as defined in Chapter 23 of the Ann Arbor City Code, the Contractor agrees to comply with the living wage provisions of Chapter 23 of the Ann Arbor City Code. The Contractor agrees to pay those employees providing Services to the City under this Agreement a "living wage," as defined in Section 1:815 of the Ann Arbor City Code, as adjusted in accordance with Section 1:815(3); to post a notice approved by the City of the applicability of Chapter 23 in every location in which regular or contract employees providing services under this Agreement are working; to maintain records of compliance; if requested by the City, to provide documentation to verify compliance; to take no action that would reduce the compensation, wages, fringe benefits, or leave available to any employee or person contracted for employment in order to pay the living wage required by Section 1:815; and otherwise to comply with the requirements of Chapter 23.

Contractor agrees that all subcontracts entered into by the Contractor shall contain similar wage provision covering subcontractor's employees who perform work on this contract.

Section 5 - Non-Discrimination

The Contractor agrees to comply, and to require its subcontractor(s) to comply, with the nondiscrimination provisions of MCL 37.2209. The Contractor further agrees to comply with the provisions of Section 9:158 of Chapter 112 of Title IX of the Ann Arbor City Code, and to assure that applicants are employed and that employees are treated during employment in a manner which provides equal employment opportunity.

Section 6 - Materials, Appliances, Employees

Unless otherwise stipulated, the Contractor shall provide and pay for all materials, labor, water, tools, equipment, light, power, transportation, and other facilities necessary or used for the execution and completion of the work. Unless otherwise specified, all materials incorporated in the permanent work shall be new, and both workmanship and materials shall be of the highest quality. The Contractor shall, if required, furnish satisfactory evidence as to the kind and quality of materials.

The Contractor shall at all times enforce strict discipline and good order among its employees, and shall seek to avoid employing on the work any unfit person or anyone not skilled in the work assigned.

Adequate sanitary facilities shall be provided by the Contractor.

Section 7 - Qualifications for Employment

The Contractor shall employ competent laborers and mechanics for the work under this Contract. For work performed under this Contract, employment preference shall be given to qualified local residents.

Section 8 - Royalties and Patents

The Contractor shall pay all royalties and license fees. It shall defend all suits or claims for infringements of any patent rights and shall hold the City harmless from loss on account of infringement except that the City shall be responsible for all infringement loss when a particular process or the product of a particular manufacturer or manufacturers is specified, unless the City has notified the Contractor prior to the signing of the Contract that the particular process or product is patented or is believed to be patented.

Section 9 - Permits and Regulations

The Contractor must secure and pay for all permits, permit or plan review fees and licenses necessary for the prosecution of the work. These include but are not limited to City building permits, right-of-way permits, lane closure permits, right-of-way occupancy permits, and the like. The City shall secure and pay for easements shown on the plans unless otherwise specified.

The Contractor shall give all notices and comply with all laws, ordinances, rules and regulations bearing on the conduct of the work as drawn and specified. If the Contractor observes that the contract documents are at variance with those requirements, it shall promptly notify the Supervising Professional in writing, and any necessary changes shall be adjusted as provided in the Contract for changes in the work.

Section 10 - Protection of the Public and of Work and Property

The Contractor is responsible for the means, methods, sequences, techniques and procedures of construction and safety programs associated with the work contemplated by this contract. The Contractor, its agents or sub-contractors, shall comply with the "General Rules and Regulations for the Construction Industry" as published by the Construction Safety Commission of the State of Michigan and to all other local, State and National laws, ordinances, rules and regulations pertaining to safety of persons and property.

The Contractor shall take all necessary and reasonable precautions to protect the safety of the public. It shall continuously maintain adequate protection of all work from damage, and shall take all necessary and reasonable precautions to adequately protect all public and private property from injury or loss arising in connection with this Contract. It shall make good any damage, injury or loss to its work and to public and private property resulting from lack of reasonable protective precautions, except as may be due to errors in the contract documents, or caused by agents or employees of the City. The Contractor shall obtain and maintain sufficient insurance to cover damage to any City property at the site by any cause.

In an emergency affecting the safety of life, or the work, or of adjoining property, the Contractor is, without special instructions or authorization from the Supervising Professional, permitted to act at its discretion to prevent the threatened loss or injury. It shall also so act, without appeal, if authorized or instructed by the Supervising Professional.

Any compensation claimed by the Contractor for emergency work shall be determined by agreement or in accordance with the terms of Claims for Extra Cost - Section 15.

Section 11 - Inspection of Work

The City shall provide sufficient competent personnel for the inspection of the work.

The Supervising Professional shall at all times have access to the work whenever it is in preparation or progress, and the Contractor shall provide proper facilities for access and for

inspection.

If the specifications, the Supervising Professional's instructions, laws, ordinances, or any public authority require any work to be specially tested or approved, the Contractor shall give the Supervising Professional timely notice of its readiness for inspection, and if the inspection is by an authority other than the Supervising Professional, of the date fixed for the inspection. Inspections by the Supervising Professional shall be made promptly, and where practicable at the source of supply. If any work should be covered up without approval or consent of the Supervising Professional, it must, if required by the Supervising Professional, be uncovered for examination and properly restored at the Contractor's expense.

Re-examination of any work may be ordered by the Supervising Professional, and, if so ordered, the work must be uncovered by the Contractor. If the work is found to be in accordance with the contract documents, the City shall pay the cost of re-examination and replacement. If the work is not in accordance with the contract documents, the Contractor shall pay the cost.

Section 12 - Superintendence

The Contractor shall keep on the work site, during its progress, a competent superintendent and any necessary assistants, all satisfactory to the Supervising Professional. The superintendent will be responsible to perform all on-site project management for the Contractor. The superintendent shall be experienced in the work required for this Contract. The superintendent shall represent the Contractor and all direction given to the superintendent shall be binding as if given to the Contractor. Important directions shall immediately be confirmed in writing to the Contractor. Other directions will be confirmed on written request. The Contractor shall give efficient superintendence to the work, using its best skill and attention.

Section 13 - Changes in the Work

The City may make changes to the quantities of work within the general scope of the Contract at any time by a written order and without notice to the sureties. If the changes add to or deduct from the extent of the work, the Contract Sum shall be adjusted accordingly. All the changes shall be executed under the conditions of the original Contract except that any claim for extension of time caused by the change shall be adjusted at the time of ordering the change.

In giving instructions, the Supervising Professional shall have authority to make minor changes in the work not involving extra cost and not inconsistent with the purposes of the work, but otherwise, except in an emergency endangering life or property, no extra work or change shall be made unless in pursuance of a written order by the Supervising Professional, and no claim for an addition to the Contract Sum shall be valid unless the additional work was ordered in writing.

The Contractor shall proceed with the work as changed and the value of the work shall be determined as provided in Claims for Extra Cost - Section 15.

Section 14 - Extension of Time

Extension of time stipulated in the Contract for completion of the work will be made if and as the Supervising Professional may deem proper under any of the following circumstances:

- (1) When work under an extra work order is added to the work under this Contract;
- (2) When the work is suspended as provided in Section 20;
- (3) When the work of the Contractor is delayed on account of conditions which could not have been foreseen, or which were beyond the control of the Contractor, and which were not

the result of its fault or negligence;

- (4) Delays in the progress of the work caused by any act or neglect of the City or of its employees or by other Contractors employed by the City;
- (5) Delay due to an act of Government;
- (6) Delay by the Supervising Professional in the furnishing of plans and necessary information;
- (7) Other cause which in the opinion of the Supervising Professional entitles the Contractor to an extension of time.

The Contractor shall notify the Supervising Professional within 7 days of an occurrence or conditions which, in the Contractor's opinion, entitle it to an extension of time. The notice shall be in writing and submitted in ample time to permit full investigation and evaluation of the Contractor's claim. The Supervising Professional shall acknowledge receipt of the Contractor's notice within 7 days of its receipt. Failure to timely provide the written notice shall constitute a waiver by the Contractor of any claim.

In situations where an extension of time in contract completion is appropriate under this or any other section of the contract, the Contractor understands and agrees that the only available adjustment for events that cause any delays in contract completion shall be extension of the required time for contract completion and that there shall be no adjustments in the money due the Contractor on account of the delay.

Section 15 - Claims for Extra Cost

If the Contractor claims that any instructions by drawings or other media issued after the date of the Contract involved extra cost under this Contract, it shall give the Supervising Professional written notice within 7 days after the receipt of the instructions, and in any event before proceeding to execute the work, except in emergency endangering life or property. The procedure shall then be as provided for Changes in the Work-Section I3. No claim shall be valid unless so made.

If the Supervising Professional orders, in writing, the performance of any work not covered by the contract documents, and for which no item of work is provided in the Contract, and for which no unit price or lump sum basis can be agreed upon, then the extra work shall be done on a Cost-Plus-Percentage basis of payment as follows:

- (1) The Contractor shall be reimbursed for all reasonable costs incurred in doing the work, and shall receive an additional payment of 15% of all the reasonable costs to cover both its indirect overhead costs and profit;
- (2) The term "Cost" shall cover all payroll charges for employees and supervision required under the specific order, together with all worker's compensation, Social Security, pension and retirement allowances and social insurance, or other regular payroll charges on same; the cost of all material and supplies required of either temporary or permanent character; rental of all power-driven equipment at agreed upon rates, together with cost of fuel and supply charges for the equipment; and any costs incurred by the Contractor as a direct result of executing the order, if approved by the Supervising Professional;
- (3) If the extra is performed under subcontract, the subcontractor shall be allowed to compute its charges as described above. The Contractor shall be permitted to add an additional charge of 5% percent to that of the subcontractor for the Contractor's supervision and contractual responsibility;

- (4) The quantities and items of work done each day shall be submitted to the Supervising Professional in a satisfactory form on the succeeding day, and shall be approved by the Supervising Professional and the Contractor or adjusted at once;
- (5) Payments of all charges for work under this Section in any one month shall be made along with normal progress payments. Retainage shall be in accordance with Progress Payments-Section 16.

No additional compensation will be provided for additional equipment, materials, personnel, overtime or special charges required to perform the work within the time requirements of the Contract.

When extra work is required and no suitable price for machinery and equipment can be determined in accordance with this Section, the hourly rate paid shall be 1/40 of the basic weekly rate listed in the Rental Rate Blue Book published by Dataquest Incorporated and applicable to the time period the equipment was first used for the extra work. The hourly rate will be deemed to include all costs of operation such as bucket or blade, fuel, maintenance, "regional factors", insurance, taxes, and the like, but not the costs of the operator.

Section 16 - Progress Payments

The Contractor shall submit each month, or at longer intervals, if it so desires, an invoice covering work performed for which it believes payment, under the Contract terms, is due. The submission shall be to the City's Finance Department - Accounting Division. The Supervising Professional will, within 10 days following submission of the invoice, prepare a certificate for payment for the work in an amount to be determined by the Supervising Professional as fairly representing the acceptable work performed during the period covered by the Contractor's invoice. To insure the proper performance of this Contract, the City will retain a percentage of the estimate in accordance with Act 524, Public Acts of 1980. The City will then, following the receipt of the Supervising Professional's Certificate, make payment to the Contractor as soon as feasible, which is anticipated will be within 15 days.

An allowance may be made in progress payments if substantial quantities of permanent material have been delivered to the site but not incorporated in the completed work if the Contractor, in the opinion of the Supervising Professional, is diligently pursuing the work under this Contract. Such materials shall be properly stored and adequately protected. Allowance in the estimate shall be at the invoice price value of the items. Notwithstanding any payment of any allowance, all risk of loss due to vandalism or any damages to the stored materials remains with the Contractor.

In the case of Contracts which include only the Furnishing and Delivering of Equipment, the payments shall be; 60% of the Contract Sum upon the delivery of all equipment to be furnished, or in the case of delivery of a usable portion of the equipment in advance of the total equipment delivery, 60% of the estimated value of the portion of the equipment may be paid upon its delivery in advance of the time of the remainder of the equipment to be furnished; 30% of the Contract Sum upon completion of erection of all equipment furnished, but not later than 60 days after the date of delivery of all of the equipment to be furnished; and payment of the final 10% on final completion of erection, testing and acceptance of all the equipment to be furnished; but not later than 180 days after the date of delivery of all of the equipment to be furnished, unless testing has been completed and shows the equipment to be unacceptable.

With each invoice for periodic payment, the Contractor shall enclose a Contractor's Declaration - Section 43, and an updated project schedule per Order of Completion - Section 2.

Section 17 - Deductions for Uncorrected Work

If the Supervising Professional decides it is inexpedient to correct work that has been damaged or that was not done in accordance with the Contract, an equitable deduction from the Contract price shall be made.

Section 18 - Correction of Work Before Final Payment

The Contractor shall promptly remove from the premises all materials condemned by the Supervising Professional as failing to meet Contract requirements, whether incorporated in the work or not, and the Contractor shall promptly replace and re-execute the work in accordance with the Contract and without expense to the City and shall bear the expense of making good all work of other contractors destroyed or damaged by the removal or replacement.

If the Contractor does not remove the condemned work and materials within 10 days after written notice, the City may remove them and, if the removed material has value, may store the material at the expense of the Contractor. If the Contractor does not pay the expense of the removal within 10 days thereafter, the City may, upon 10 days written notice, sell the removed materials at auction or private sale and shall pay to the Contractor the net proceeds, after deducting all costs and expenses that should have been borne by the Contractor. If the removed material has no value, the Contractor must pay the City the expenses for disposal within 10 days of invoice for the disposal costs.

The inspection or lack of inspection of any material or work pertaining to this Contract shall not relieve the Contractor of its obligation to fulfill this Contract and defective work shall be made good. Unsuitable materials may be rejected by the Supervising Professional notwithstanding that the work and materials have been previously overlooked by the Supervising Professional and accepted or estimated for payment or paid for. If the work or any part shall be found defective at any time before the final acceptance of the whole work, the Contractor shall forthwith make good the defect in a manner satisfactory to the Supervising Professional. The judgment and the decision of the Supervising Professional as to whether the materials supplied and the work done under this Contract comply with the requirements of the Contract shall be conclusive and final.

Section 19 - Acceptance and Final Payment

Upon receipt of written notice that the work is ready for final inspection and acceptance, the Supervising Professional will promptly make the inspection. When the Supervising Professional finds the work acceptable under the Contract and the Contract fully performed, the Supervising Professional will promptly sign and issue a final certificate stating that the work required by this Contract has been completed and is accepted by the City under the terms and conditions of the Contract. The entire balance found to be due the Contractor, including the retained percentage, shall be paid to the Contractor by the City within 30 days after the date of the final certificate.

Before issuance of final certificates, the Contractor shall file with the City:

- (1) The consent of the surety to payment of the final estimate;
- (2) The Contractor's Affidavit in the form required by Section 44.

In case the Affidavit or consent is not furnished, the City may retain out of any amount due the Contractor, sums sufficient to cover all lienable claims.

The making and acceptance of the final payment shall constitute a waiver of all claims by the City except those arising from:

- (1) unsettled liens;

- (2) faulty work appearing within 12 months after final payment;
- (3) hidden defects in meeting the requirements of the plans and specifications;
- (4) manufacturer's guarantees.

It shall also constitute a waiver of all claims by the Contractor, except those previously made and still unsettled.

Section 20 - Suspension of Work

The City may at any time suspend the work, or any part by giving 5 days notice to the Contractor in writing. The work shall be resumed by the Contractor within 10 days after the date fixed in the written notice from the City to the Contractor to do so. The City shall reimburse the Contractor for expense incurred by the Contractor in connection with the work under this Contract as a result of the suspension.

If the work, or any part, shall be stopped by the notice in writing, and if the City does not give notice in writing to the Contractor to resume work at a date within 90 days of the date fixed in the written notice to suspend, then the Contractor may abandon that portion of the work suspended and will be entitled to the estimates and payments for all work done on the portions abandoned, if any, plus 10% of the value of the work abandoned, to compensate for loss of overhead, plant expense, and anticipated profit.

Section 21 - Delays and the City's Right to Terminate Contract

If the Contractor refuses or fails to prosecute the work, or any separate part of it, with the diligence required to insure completion, ready for operation, within the allowable number of consecutive calendar days specified plus extensions, or fails to complete the work within the required time, the City may, by written notice to the Contractor, terminate its right to proceed with the work or any part of the work as to which there has been delay. After providing the notice the City may take over the work and prosecute it to completion, by contract or otherwise, and the Contractor and its sureties shall be liable to the City for any excess cost to the City. If the Contractor's right to proceed is terminated, the City may take possession of and utilize in completing the work, any materials, appliances and plant as may be on the site of the work and useful for completing the work. The right of the Contractor to proceed shall not be terminated or the Contractor charged with liquidated damages where an extension of time is granted under Extension of Time - Section 14.

If the Contractor is adjudged a bankrupt, or if it makes a general assignment for the benefit of creditors, or if a receiver is appointed on account of its insolvency, or if it persistently or repeatedly refuses or fails except in cases for which extension of time is provided, to supply enough properly skilled workers or proper materials, or if it fails to make prompt payments to subcontractors or for material or labor, or persistently disregards laws, ordinances or the instructions of the Supervising Professional, or otherwise is guilty of a substantial violation of any provision of the Contract, then the City, upon the certificate of the Supervising Professional that sufficient cause exists to justify such action, may, without prejudice to any other right or remedy and after giving the Contractor 3 days written notice, terminate this Contract. The City may then take possession of the premises and of all materials, tools and appliances thereon and without prejudice to any other remedy it may have, make good the deficiencies or finish the work by whatever method it may deem expedient, and deduct the cost from the payment due the Contractor. The Contractor shall not be entitled to receive any further payment until the work is finished. If the expense of finishing the work, including compensation for additional managerial and administrative services exceeds the unpaid balance of the Contract Sum, the Contractor and its surety are liable to the City for any excess cost incurred. The expense incurred by the City, and the damage incurred through the Contractor's default, shall be certified by the Supervising Professional.

Section 22 - Contractor's Right to Terminate Contract

If the work should be stopped under an order of any court, or other public authority, for a period of 3 months, through no act or fault of the Contractor or of anyone employed by it, then the Contractor may, upon 7 days written notice to the City, terminate this Contract and recover from the City payment for all acceptable work executed plus reasonable profit.

Section 23 - City's Right To Do Work

If the Contractor should neglect to prosecute the work properly or fail to perform any provision of this Contract, the City, 3 days after giving written notice to the Contractor and its surety may, without prejudice to any other remedy the City may have, make good the deficiencies and may deduct the cost from the payment due to the Contractor.

Section 24 - Removal of Equipment and Supplies

In case of termination of this Contract before completion, from any or no cause, the Contractor, if notified to do so by the City, shall promptly remove any part or all of its equipment and supplies from the property of the City, failing which the City shall have the right to remove the equipment and supplies at the expense of the Contractor.

The removed equipment and supplies may be stored by the City and, if all costs of removal and storage are not paid by the Contractor within 10 days of invoicing, the City upon 10 days written notice may sell the equipment and supplies at auction or private sale, and shall pay the Contractor the net proceeds after deducting all costs and expenses that should have been borne by the Contractor and after deducting all amounts claimed due by any lien holder of the equipment or supplies.

Section 25 - Responsibility for Work and Warranties

The Contractor assumes full responsibility for any and all materials and equipment used in the construction of the work and may not make claims against the City for damages to materials and equipment from any cause except negligence or willful act of the City. Until its final acceptance, the Contractor shall be responsible for damage to or destruction of the project (except for any part covered by Partial Completion and Acceptance - Section 26). The Contractor shall make good all work damaged or destroyed before acceptance. All risk of loss remains with the Contractor until final acceptance of the work (Section 19) or partial acceptance (Section 26). The Contractor is advised to investigate obtaining its own builders risk insurance.

The Contractor shall guarantee the quality of the work for a period of one year. The Contractor shall also unconditionally guarantee the quality of all equipment and materials that are furnished and installed under the contract for a period of one year. At the end of one year after the Contractor's receipt of final payment, the complete work, including equipment and materials furnished and installed under the contract, shall be inspected by the Contractor and the Supervising Professional. Any defects shall be corrected by the Contractor at its expense as soon as practicable but in all cases within 60 days. Any defects that are identified prior to the end of one year shall also be inspected by the Contractor and the Supervising Professional and shall be corrected by the Contractor at its expense as soon as practicable but in all cases within 60 days. The Contractor shall assign all manufacturer or material supplier warranties to the City prior to final payment. The assignment shall not relieve the Contractor of its obligations under this paragraph to correct defects.

Section 26 - Partial Completion and Acceptance

If at any time prior to the issuance of the final certificate referred to in Acceptance and Final Payment - Section 19, any portion of the permanent construction has been satisfactorily completed, and if the Supervising Professional determines that portion of the permanent construction is not required for the operations of the Contractor but is needed by the City, the Supervising Professional shall issue to the Contractor a certificate of partial completion, and immediately the City may take over and use the portion of the permanent construction described in the certificate, and exclude the Contractor from that portion.

The issuance of a certificate of partial completion shall not constitute an extension of the Contractor's time to complete the portion of the permanent construction to which it relates if the Contractor has failed to complete it in accordance with the terms of this Contract. The issuance of the certificate shall not release the Contractor or its sureties from any obligations under this Contract including bonds.

If prior use increases the cost of, or delays the work, the Contractor shall be entitled to extra compensation, or extension of time, or both, as the Supervising Professional may determine.

Section 27 - Payments Withheld Prior to Final Acceptance of Work

The City may withhold or, on account of subsequently discovered evidence, nullify the whole or part of any certificate to the extent reasonably appropriate to protect the City from loss on account of:

- (1) Defective work not remedied;
- (2) Claims filed or reasonable evidence indicating probable filing of claims by other parties against the Contractor;
- (3) Failure of the Contractor to make payments properly to subcontractors or for material or labor;
- (4) Damage to another Contractor.

When the above grounds are removed or the Contractor provides a Surety Bond satisfactory to the City which will protect the City in the amount withheld, payment shall be made for amounts withheld under this section.

Section 28 - Contractor's Insurance

- (1) The Contractor shall procure and maintain during the life of this Contract, including the guarantee period and during any warranty work, such insurance policies, including those set forth below, as will protect itself and the City from all claims for bodily injuries, death or property damage which may arise under this Contract; whether the act(s) or omission(s) giving rise to the claim were made by the Contractor or by any subcontractor or anyone employed by them directly or indirectly. In the case of all contracts involving on-site work, the Contractor shall provide to the City, before the commencement of any work under this contract, certificates of insurance and other documentation satisfactory to the City demonstrating it has obtained the policies and endorsements required on behalf of itself, and when requested, any subcontractor(s). The certificates of insurance endorsements and/or copies of policy language shall document that the Contractor satisfies the following minimum requirements.

- (a) Worker's Compensation Insurance in accordance with all applicable state and federal statutes. Further, Employers Liability Coverage shall be obtained in the following minimum amounts:

Bodily Injury by Accident - \$500,000 each accident
Bodily Injury by Disease - \$500,000 each employee
Bodily Injury by Disease - \$500,000 each policy limit

- (b) Commercial General Liability Insurance equivalent to, as a minimum, Insurance Services Office form CG 00 01 07 98 or current equivalent. The City of Ann Arbor shall be named as an additional insured. There shall be no added exclusions or limiting endorsements specifically for the following coverages: Products and Completed Operations, Explosion, Collapse and Underground coverage or Pollution. Further there shall be no added exclusions or limiting endorsements which diminish the City's protections as an additional insured under the policy. The following minimum limits of liability are required:

| | |
|-------------|--|
| \$1,000,000 | Each occurrence as respect Bodily Injury Liability or Property Damage Liability, or both combined. |
| \$2,000,000 | Per Job General Aggregate |
| \$1,000,000 | Personal and Advertising Injury |
| \$2,000,000 | Products and Completed Operations Aggregate |

- (c) Motor Vehicle Liability Insurance, including Michigan No-Fault Coverages, equivalent to, as a minimum, Insurance Services Office form CA 00 01 07 97 or current equivalent. Coverage shall include all owned vehicles, all non-owned vehicles and all hired vehicles. The City of Ann Arbor shall be named as an additional insured. There shall be no added exclusions or limiting endorsements which diminish the City's protections as an additional insured under the policy. Further, the limits of liability shall be \$1,000,000 for each occurrence as respects Bodily Injury Liability or Property Damage Liability, or both combined.

- (d) Umbrella/Excess Liability Insurance shall be provided to apply excess of the Commercial General Liability, Employers Liability and the Motor Vehicle coverage enumerated above, for each occurrence and for aggregate in the amount of \$1,000,000.

- (2) Insurance required under subsection (1)(b) and (1)(c) above shall be considered primary as respects any other valid or collectible insurance that the City may possess, including any self-insured retentions the City may have; and any other insurance the City does possess shall be considered excess insurance only and shall not be required to contribute with this insurance. Further, the Contractor agrees to waive any right of recovery by its insurer against the City.
- (3) Insurance companies and policy forms are subject to approval of the City Attorney, which approval shall not be unreasonably withheld. Documentation must provide and demonstrate an unconditional 30 day written notice of cancellation in favor of the City of Ann Arbor. Further, the documentation must explicitly state the following: (a) the policy number; name of insurance company; name and address of the agent or authorized representative; name and address of insured; project name; policy expiration date; and specific coverage amounts; (b) any deductibles or self-insured retentions which shall be approved by the City, in its sole discretion; (c) that the policy conforms to the requirements specified Contractor shall furnish the City with satisfactory certificates of insurance and endorsements prior to commencement of any work. Upon request, the Contractor shall provide within 30 days a copy of the policy(ies) to the City. If any of the above coverages expire by their terms during the term of this Contract, the Contractor shall deliver proof of

renewal and/or new policies and endorsements to the Administering Service Area/Unit at least ten days prior to the expiration date.

- (4) Any Insurance provider of Contractor shall be admitted and authorized to do business in the State of Michigan and shall carry and maintain a minimum rating assigned by A.M. Best & Company's Key Rating Guide of "A-" Overall and a minimum Financial Size Category of "V". Insurance policies and certificates issued by non-admitted insurance companies are not acceptable unless approved in writing by the City.
- (5) City reserves the right to require additional coverage and/or coverage amounts as may be included from time to time in the Detailed Specifications for the Project.
- (6) The provisions of General Condition 28 shall survive the expiration or earlier termination of this contract for any reason.

Section 29 - Surety Bonds

Bonds will be required from the successful bidder as follows:

- (1) A Performance Bond to the City of Ann Arbor for the amount of the bid(s) accepted;
- (2) A Labor and Material Bond to the City of Ann Arbor for the amount of the bid(s) accepted.

Bonds shall be executed on forms supplied by the City in a manner and by a Surety Company authorized to transact business in Michigan and satisfactory to the City Attorney.

Section 30 - Damage Claims

The Contractor shall be held responsible for all damages to property of the City or others, caused by or resulting from the negligence of the Contractor, its employees, or agents during the progress of or connected with the prosecution of the work, whether within the limits of the work or elsewhere. The Contractor must restore all property injured including sidewalks, curbing, sodding, pipes, conduit, sewers or other public or private property to not less than its original condition with new work.

Section 31 - Refusal to Obey Instructions

If the Contractor refuses to obey the instructions of the Supervising Professional, the Supervising Professional shall withdraw inspection from the work, and no payments will be made for work performed thereafter nor may work be performed thereafter until the Supervising Professional shall have again authorized the work to proceed.

Section 32 - Assignment

Neither party to the Contract shall assign the Contract without the written consent of the other. The Contractor may assign any monies due to it to a third party acceptable to the City.

Section 33 - Rights of Various Interests

Whenever work being done by the City's forces or by other contractors is contiguous to work covered by this Contract, the respective rights of the various interests involved shall be established by the Supervising Professional, to secure the completion of the various portions of the work in general harmony.

The Contractor is responsible to coordinate all aspects of the work, including coordination of, and

with, utility companies and other contractors whose work impacts this project.

Section 34 - Subcontracts

The Contractor shall not award any work to any subcontractor without prior written approval of the City. The approval will not be given until the Contractor submits to the City a written statement concerning the proposed award to the subcontractor. The statement shall contain all information the City may require.

The Contractor shall be as fully responsible to the City for the acts and omissions of its subcontractors, and of persons either directly or indirectly employed by them, as it is for the acts and omissions of persons directly employed by it.

The Contractor shall cause appropriate provisions to be inserted in all subcontracts relative to the work to bind subcontractors to the Contractor by the terms of the General Conditions and all other contract documents applicable to the work of the subcontractors and to give the Contractor the same power to terminate any subcontract that the City may exercise over the Contractor under any provision of the contract documents.

Nothing contained in the contract documents shall create any contractual relation between any subcontractor and the City.

Section 35 - Supervising Professional's Status

The Supervising Professional has the right to inspect any or all work. The Supervising Professional has authority to stop the work whenever stoppage may be appropriate to insure the proper execution of the Contract. The Supervising Professional has the authority to reject all work and materials which do not conform to the Contract and to decide questions which arise in the execution of the work.

The Supervising Professional shall make all measurements and determinations of quantities. Those measurements and determinations are final and conclusive between the parties.

Section 36 - Supervising Professional's Decisions

The Supervising Professional shall, within a reasonable time after their presentation to the Supervising Professional, make decisions in writing on all claims of the City or the Contractor and on all other matters relating to the execution and progress of the work or the interpretation of the contract documents.

Section 37 - Storing Materials and Supplies

Materials and supplies may be stored at the site of the work at locations agreeable to the City unless specific exception is listed elsewhere in these documents. Ample way for foot traffic and drainage must be provided, and gutters must, at all times, be kept free from obstruction. Traffic on streets shall be interfered with as little as possible. The Contractor may not enter or occupy with agents, employees, tools, or material any private property without first obtaining written permission from its owner. A copy of the permission shall be furnished to the Supervising Professional.

Section 38 - Lands for Work

The Contractor shall provide, at its own expense and without liability to the City, any additional land and access that may be required for temporary construction facilities or for storage of

materials.

Section 39 - Cleaning Up

The Contractor shall, as directed by the Supervising Professional, remove at its own expense from the City's property and from all public and private property all temporary structures, rubbish and waste materials resulting from its operations unless otherwise specifically approved, in writing, by the Supervising Professional.

Section 40 - Salvage

The Supervising Professional may designate for salvage any materials from existing structures or underground services. Materials so designated remain City property and shall be transported or stored at a location as the Supervising Professional may direct.

Section 41 - Night, Saturday or Sunday Work

No night or Sunday work (without prior written City approval) will be permitted except in the case of an emergency and then only to the extent absolutely necessary. The City may allow night work which, in the opinion of the Supervising Professional, can be satisfactorily performed at night. Night work is any work between 8:00 p.m. and 7:00 a.m. No Saturday work will be permitted unless the Contractor gives the Supervising Professional at least 48 hours but not more than 5 days notice of the Contractor's intention to work the upcoming Saturday.

Section 42 - Sales Taxes

Under State law the City is exempt from the assessment of State Sales Tax on its direct purchases. Contractors who acquire materials, equipment, supplies, etc. for incorporation in City projects are not likewise exempt. State Law shall prevail. The Bidder shall familiarize itself with the State Law and prepare its Bid accordingly. No extra payment will be allowed under this Contract for failure of the Contractor to make proper allowance in this bid for taxes it must pay.

Section 43

CONTRACTOR'S DECLARATION

I hereby declare that I have not, during the period _____, 20____, to _____, 20____, performed any work, furnished any materials, sustained any loss, damage or delay, or otherwise done anything in addition to the regular items (or executed change orders) set forth in the Contract titled **Street Surface Treatment Project – FY2019; ITB No. 4530; File 2018-020**, for which I shall ask, demand, sue for, or claim compensation or extension of time from the City, except as I hereby make claim for additional compensation or extension of time as set forth on the attached itemized statement. I further declare that I have paid all payroll obligations related to this Contract that have become due during the above period and that all invoices related to this Contract received more than 30 days prior to this declaration have been paid in full except as listed below.

There is/is not (Contractor please circle one and strike one as appropriate) an itemized statement attached regarding a request for additional compensation or extension of time.

Contractor

Date

By _____
(Signature)

Its _____
(Title of Office)

Past due invoices, if any, are listed below.

STANDARD SPECIFICATIONS

Perform all work under this contract in accordance with the Michigan Department of Transportation (MDOT) 2012 Standard Specifications for Construction and/or in accordance with the City of Ann Arbor Detailed Specifications, MDOT Supplemental Specifications, and MDOT Special Provisions included in the contract. Any reference to the Michigan Department of Transportation (the "Department") in the above Standard Specifications, Supplemental Specifications, and Special Provisions shall also mean the City of Ann Arbor.

The Michigan Department of Transportation 2012 Standard Specification for Construction may be downloaded from the following web link:

<http://mdotcf.state.mi.us/public/specbook/2012/>

CITY OF ANN ARBOR
DETAILED SPECIFICATION
FOR
GENERAL CONDITIONS

AA:DAD

1 of 2

04/17/18

a. Description. This item comprises all work described and required by the plans and specifications at each project location for which the contract contains no item(s) of work, including but not limited to the following:

- Scheduling, coordination, and organization of all work, subcontractors, suppliers, testing, inspection, surveying, and staking.
- Coordination of, and cooperation with, other contractors, agencies, departments, and utilities.
- Protection and maintenance of utilities.
- Maintaining drainage.
- Maintaining driveways drive openings, sidewalks, bike paths, mail deliveries, and solid waste/recycle pick-ups.
- Storing all materials and equipment off lawn areas.
- Temporary relocation and final replacement/re-setting of mailboxes.
- Coordination efforts to furnish various surface treatment applications/mixtures and HMA mixtures as directed by the Engineer
- Coordination efforts to furnish and operate various-size vehicles/equipment as directed by the Engineer
- Furnishing and operating vacuum-type street and utility structure cleaning equipment as directed by the Engineer
- Protecting all sewers, and drainage and utility structures including manholes, gate wells, valve boxes, inlet structures from damage and contamination by debris and construction materials. Keeping structures clean of construction debris and properly covered at all times during the construction. Immediately cleaning any structures and/or sewers contaminated with construction debris resulting from Contractor operations and/or work activities.
- Furnishing and operating both vibratory plate and pneumatic-type (“pogo-stick”) compactors
- Furnishing and operating a backhoe during all work activities
- Furnishing and operating a jackhammer and air compressor during all work activities
- Noise and dust control
- Mobilization(s) and demobilization(s).
- Furnishing submittals and certifications for materials and supplies
- All miscellaneous and incidental items such as overhead, insurance, and permits.
- Meeting all requirements relating to Debarment Certification, Davis Bacon Act, and Disadvantaged Business Enterprise, and providing the necessary documentation.

The Appendix of the contract documents provides data pertaining to existing soil borings and pavement sections to assist the Engineer and Contractor determine the soil conditions existing within the construction areas of the various project locations. The City in no way guarantees existing conditions to be the same as shown in the data. The Contractor is solely responsible for any/all conclusions it may draw from the data.

Quantities as given are approximate and are estimates for bidding purposes. The City does not guarantee their totals and they may vary by any amount. While it is the City's intent to complete the project substantially as drawn and specified herein, quantities may be changed or reduced to zero for cost savings or other reasons. **The City reserves the right to change the quantities; however, the City will not allow the Contractor to adjust unit price(s) due to such change.**

b. **Materials.** None Specified.

c. **Construction.** Not specified.

d. **Measurement and Payment.** Measure and pay for the completed work, as described, at the contract unit price using the following pay item:

| <u>Pay Item</u> | <u>Pay Unit</u> |
|---------------------------------|-----------------|
| General Conditions, Max \$_____ | Lump Sum |

Measure **General Conditions, Max \$_____** by the unit lump sum and pay for it at the contract unit price, which price includes costs for all labor, equipment and materials necessary to complete the work.

The Contractor is fully responsible for all direct and/or indirect damages to property caused by unclean or damaged sewers or structures resulting from its operations and/or work activities including any/all cost associated with such damages.

Measurement will be on a pro rata basis at the time of each progress payment, and based on the ratio of work completed during the payment period and the total contract amount. When all of the work of this Contract is complete, the measurement of this item shall be 1.0 Lump Sum, less any deductions incurred for inadequate performance as described herein. This amount will not increase for any reason, including extensions of time, extras, and/or additional work.

CITY OF ANN ARBOR
DETAILED SPECIFICATION
FOR
PROJECT SUPERVISION

AA:DAD

1 of 4

04/17/18

a. Description. The Contractor shall provide supervision in accordance with the City of Ann Arbor Standard Specifications, subsections 104.07 and 107.15 of the Michigan Department of Transportation (MDOT) 2012 Standard Specifications for Construction, and as described herein.

The Contractor shall designate a full-time Project Supervisor to act as the Contractor's agent/representative, and to be responsible for scheduling and coordination of all subcontractors, suppliers, other governmental agencies, and all public and private utility companies.

The Project Supervisor shall not be an active crewmember of the Contractor, shall not be an active member or employee of any subcontractor's work force, and shall not perform general or specialized labor tasks. The Project Supervisor shall be a full-time employee of the General Contractor and shall have all needed authority to make binding decisions on behalf of the Contractor in all matters pertaining to performance and execution of the work of the project.

The Project Supervisor shall work exclusively on this project, and shall put forth his/her full effort into the organization and coordination of the work of this project.

One week prior to the pre-construction meeting, the Contractor shall designate a proposed Project Supervisor by name, and shall furnish the Engineer with a current, thorough, detailed summary of the proposed Project Supervisor's work history, outlining all previous supervisory experience on projects of a similar size and nature. The detailed work history shall include personal and professional references (names and phone numbers) of persons (previous owners or agents) who can attest to the qualifications and work history of the proposed Project Supervisor. Proposed candidates for Project Supervisor shall have a demonstrated ability to work harmoniously with the Engineer, the City, the public, subcontractors, and all other parties typically involved with work of this nature. The Engineer will have the authority to reject a proposed Project Supervisor whom he/she considers unqualified.

The Project Supervisor shall be available 24 hours-per-day to provide proper supervision, coordination and scheduling of the project for the duration of the Contract. The Contractor shall furnish the City with telephone numbers of the Project Supervisor in order to provide 24 hour-per-day access during business and non-business hours, including weekends and holidays.

The Project Supervisor shall be equipped by the Contractor with a "smart" mobile telephone with "data" and "text" capabilities to provide the City with 24 hour-per-day access to him/her during daily construction activities, during transit to and from the construction site, and during all non-business hours including weekends and holidays.

The Project Supervisor shall be equipped with assistants as necessary to provide project supervision as specified herein, and in accordance with the Contract.

1. Duties and Responsibilities. The Project Supervisor shall work harmoniously with the Engineer, the City, the public, subcontractors, and all other parties typically involved with work of this nature.

The Project Supervisor shall have a thorough, detailed understanding and working knowledge of all construction practices and methods specified elsewhere herein, as well as the handling, placement, testing and inspection of aggregates, aggregate products, bituminous concrete, Portland cement concrete materials, and other such materials and products related to the work of this project.

The Project Supervisor shall be responsible for all of the work of all of the Contractor, subcontractor and/or supplier work forces.

The Project Supervisor shall be responsible for proper and adequate maintenance (emissions, safety, and general operation) of all of the Contractor's, subcontractors' and suppliers' equipment and vehicles. The Project Supervisor shall make all needed diligent and good faith efforts to ensure that all equipment utilized in the performance of the work is properly maintained, safe, and complies with all legal and environmental requirements of the work as set forth in section 107.15 of the MDOT 2012 Standard Specifications for Construction.

The Project Supervisor shall be responsible for the legal, proper and safe parking/storage of all of the Contractor, subcontractor and/or supplier equipment, work vehicles, and employee's vehicles.

The Project Supervisor shall schedule and coordinate the work of all parties involved in the project, including utility companies, testing agencies, governmental agencies, all City departments (such as Utilities and Transportation), and City inspectors.

The Project Supervisor shall coordinate and schedule the work of any independent survey crews retained by the Engineer or City to witness and reset existing and new geographic/benchmark monuments. Failure to have existing monuments witnessed and reset may result in delays to the Contractor's work. Costs for such delays will be the Contractor's sole responsibility. The Project Supervisor shall also schedule and complete all needed survey request forms required to schedule the services of survey personnel to properly layout all elements of the project work in accordance with the City of Ann Arbor Public Services Area Standard Specifications and the MDOT 2012 Standard Specifications for Construction.

The Project Supervisor shall coordinate and schedule inspection performed by the City and Consultants (including material testing firms) in a timely manner, to assure proper and timely testing and inspection of the work.

The Project Supervisor shall submit to the Engineer, an updated, detailed schedule of the proposed work on a weekly basis, and an update of all proposed changes on a daily basis.

The Project Supervisor and all subcontractors shall attend a weekly progress meeting chaired by the Engineer to discuss the work. Upon the completion of each meeting, the Engineer shall prepare and distribute, to all present, a written summary of the meeting's

minutes. Those in attendance shall review the minutes and, if necessary, comment on any deficiencies or errors prior to or at the next scheduled progress meeting.

2. **Additional Performance Requirements.** If, in the sole opinion of the Engineer, the Project Supervisor is not adequately performing the duties as outlined in this detailed specification, the following system of notices will be given to the contractor with the associated penalties:

First Notice – The Engineer will issue a warning in writing to the Contractor detailing the deficiencies in the Project Supervision. The Contractor must respond within seven (7) calendar days in writing with a plan to correct the stated deficiencies. Failure to respond within seven (7) calendar days will result in the issuing of a second notice.

Second Notice – The Engineer will issue a second warning in writing to the Contractor further detailing the deficiencies in the Project Supervision. The Engineer will deduct 10%, or \$10,000, whichever is greater, from the original contract amount bid for the Project Supervision contract item of work. The Contractor must respond within seven (7) calendar days in writing with a plan to correct the stated deficiencies. Failure to respond within seven (7) calendar days will result in the issuing of a third notice. At this time, the Engineer reserves the right to meet with personnel with the necessary authority within the Contractor's organization to discuss the deficiencies in the Project Supervision.

Third Notice – The Engineer will issue a third notice in writing to the Contractor further detailing the deficiencies in the Project Supervision. The Engineer will deduct 25%, or \$25,000, whichever is greater, from the original contract amount bid for the Project Supervision contract item of work, and the Contractor will remove and replace the Project Supervisor immediately with another individual approved by the Engineer.

Should, in the sole opinion of the Engineer, the Project Supervisor fail to perform his/her duties and responsibilities as described herein to such a degree that the successful completion of the project is put in jeopardy, the above system of notices may be foregone, and the Contractor shall immediately replace the Project Supervisor upon receipt of written notice. The Engineer, in its determination, will consider failure by the Contractor to provide adequate project supervision as a basis to suspend work without the extension of contract time or additional compensation.

If the original Project Supervision contract amount is insufficient to cover said deductions, the Engineer will reduce Project Supervision contract amount to zero and will generate a contract modification to assess a penalty to cover the difference between the Project Supervision contract amount and the total amount of the deduction(s). The expectation is that the Project Supervision contract amount will be sufficient to cover any deductions.

b. Materials. None Specified.

c. Construction. Not specified.

d. Measurement and Payment. Measure and pay for the completed work, as described, at the contract unit price using the following pay item:

Pay Item

Pay Unit

Project Supervision, Max \$____Lump Sum

Measure **Project Supervision, Max \$____** by the unit lump sum and pay for it at the contract unit price, which price includes costs for all labor, equipment and materials necessary to complete the work.

Measurement will be on a pro rata basis at the time of each progress payment, and based on the ratio of work completed during the payment period and the total contract amount. When all of the work of this Contract is complete, the measurement of this item shall be 1.0 Lump Sum, less any deductions incurred for inadequate performance as described herein. This amount will not increase for any reason, including extensions of time, extras, and/or additional work.

CITY OF ANN ARBOR
DETAILED SPECIFICATION
FOR
CERTIFIED PAYROLL COMPLIANCE AND REPORTING

AA:MGN/DD

1 of 2

04/17/18

a. Description. This specification covers all administrative requirements, payroll reporting procedures to be followed by Contractors performing work on City-sponsored public improvements projects, and all other miscellaneous and incidental costs associated with complying with the applicable sections of the City of Ann Arbor Code of Ordinances with regard to payment of prevailing wages and its Prevailing Wage Compliance policy.

The intent of this specification is **not** to include the actual labor costs associated with the payment of prevailing wages as required. Properly incorporate those costs in all other contract items of work bid for the project.

b. General. The Contractor will comply with all applicable sections of Federal and State prevailing wage laws, duly promulgated regulations, the City of Ann Arbor Code of Ordinances, and its Prevailing Wage Compliance Policy as defined within the contract documents. The Contractor shall provide the required certified payrolls, city-required declarations, and reports requested elsewhere in the contract documents within the timeline(s) stipulated therein.

The Contractor shall also provide corrected copies of any submitted documents found to contain errors, omissions, inconsistencies, or other defects that render the report invalid. Provide the corrected copies when requested by the Supervising Professional.

The Contractor shall also attend any required meetings as needed to fully discuss and ensure compliance with the contract requirements regarding prevailing wage compliance. The Contractor shall require all employees engaged in on-site work to participate in, provide the requested information to the extent practicable, and cooperate in the interview process. The City of Ann Arbor will provided the needed language interpreters in order to perform wage rate interviews or other field investigations as needed.

Submit certified payrolls on City-provided forms or forms used by the Contractor, as long as the Contractor forms contain all required payroll information. If the Contractor elects to provide its own forms, the Supervising Professional shall approve of their use prior to the beginning of on-site work.

c. Unbalanced Bidding. The City of Ann Arbor will examine the submitted cost for this item of work prior to contract award. If the City determines, in its sole discretion that the costs bid by the Contractor for complying with the contract requirements are not reasonable, accurately reported or contain discrepancies, the City reserves the right to request additional documentation that fully supports and justifies the price as bid. Should the submitted information not be determined to be reasonable or justify the costs, the City reserves the right to pursue award of the contract to the second low bidder without penalty or prejudice to any other remedies that it may have or may elect to exercise with respect to the original low-bidder.

The City will not extend the contract completion date as a result of its investigation of the as-bid amount for this item of work, even if the anticipated contract award date must be adjusted. The only exception will be if the Contractor adequately demonstrates that their costs were appropriate

and justifiable. In such case, the City will adjust the contract completion date by the number of calendar days commensurate with the length of its investigation if it cannot meet the published Notice to Proceed date of the work. The City will not allow adjustments to contract unit prices for all other items of work due to the adjustment of contract completion date.

d. Measurement and Payment. Measure and pay for the completed work, as described, at the contract unit price using the following pay item:

| <u>Pay Item</u> | <u>Pay Unit</u> |
|--|-----------------|
| Certified Payroll Compliance and Reporting | Lump Sum |

Measure **Certified Payroll Compliance and Reporting** by the unit lump sum and pay for it at the contract unit price, which price includes costs for all supervisory, accounting, and administrative labor, and equipment and materials necessary to complete the work of monitoring, performing and maintaining compliance with the tasks required of this Detailed Specification.

Measurement will be on a pro rata basis at the time of each progress payment, and based on the ratio of work completed during the payment period and the total contract amount. When all of the work of this Contract is complete, the measurement of this item shall be 1.0 Lump Sum, less any deductions incurred for inadequate performance as described herein. This amount will not increase for any reason, including extensions of time, extras, and/or additional work.

CITY OF ANN ARBOR
DETAILED SPECIFICATION
FOR
RESIDENT NOTIFICATION

AA:DAD

1 of 1

04/17/18

a. Description. This work consists of notifying in writing all affected residents and/or property/business owners of any proposed surface treatment work on all major and minor (local) City streets, unless otherwise directed by the Engineer. Provide written notification with the following information:

1. Date of notification to affected residents.
2. The nature and duration of the planned work, disruption, and/or closure.
3. Request resident and/or property/business owner not to park on street during the planned work operation.
4. The name, address and telephone numbers of the Contractor, the Engineer, and appropriate City departments.

At the preconstruction meeting or no later than seven (7) business days prior to commencement of any contract work, submit to the Engineer for approval a notification plan (including the proposed written notification).

No construction will begin for work where written notification to is not complete. The Engineer will not give any consideration to claim(s) for contract extension of time resulting from failure to fulfill the requirements of the detailed specification.

b. Materials. None specified.

c. Construction. At least 48 hours in advance of any surface treatment work distribute approved notices to affected residents and/or property/business owners within the planned work limits.

d. Measurement and Payment. Measure and pay for the completed work, as described, at the contract unit price using the following pay item:

| <u>Pay Item</u> | <u>Pay Unit</u> |
|-----------------------------|-----------------|
| Resident Notification | Lump Sum |

Measure **Resident Notification** by the unit lump sum and pay for it at the contract unit price, which price includes costs for all labor, equipment and materials necessary to complete the work.

Measurement will be on a pro rata basis at the time of each progress payment, and based on the ratio of work completed during the payment period and the total contract amount. When all of the work of this Contract is complete, the measurement of this item shall be 1.0 Lump Sum, less any deductions incurred for inadequate performance as described herein. This amount will not increase for any reason, including extensions of time, extras, and/or additional work.

CITY OF ANN ARBOR
DETAILED SPECIFICATION
FOR
MATERIAL AND SUPPLIES CERTIFICATIONS

AA:DAD

1 of 1

04/17/18

a. Description. This work includes furnishing material or supply certifications to the Engineer for review and approval a minimum of three business days prior to any scheduled delivery, installation, and/or construction of such. The manufacturer or supplier shall certify (by testing or other means approved by the Engineer) that any/all of following materials or supplies used to complete the project work are compliant with the specifications in the Contract.

HMA materials

Hot-poured Joint Sealants

Cements, coatings, admixtures and curing materials

Sands and Aggregates

Steel and Fabricated metal

Portland Cement Concrete Mixtures

Reinforcing Steel for Concrete

Reinforcing Fibers for Concrete

Pre-cast Concrete products

Sanitary Sewer Pipe

Storm Sewer Pipe

Water Main Pipe

Corrugated Metal Pipe

High Density Polyethylene Pipe

Timber for retaining walls

Modular Concrete Block for retaining walls

Edge Drain and Underdrain Pipe

Geotextile Filter Fabric and Stabilization Fabric/Grids

b. Materials. None specified.

c. Construction. Not specified.

d. Measurement and Payment. The Engineer will not pay for the work required of this detailed specification separately. The Contractor shall include it in the contract unit price bid for the pay Item **General Conditions, Maximum, \$_____**.

CITY OF ANN ARBOR
DETAILED SPECIFICATION
FOR
VACUUM TYPE CLEANING EQUIPMENT

AA:DAD

1 of 1

04/17/18

a. Description. This work includes furnishing and operating throughout the construction period, vacuum type street cleaning and utility structure cleaning equipment (Vac-All, Vactor, etc.) approved by the Engineer, as and when directed by the Engineer for dust control, for dirt/debris control, and for street cleaning immediately prior to paving, and for street and utility structure cleaning after any and all paving.

b. Materials. None specified.

c. Construction. The Contractor shall furnish and operate throughout the construction period, vacuum type street cleaning and utility structure cleaning equipment (Vac-All, Vactor, etc.) approved by the Engineer. When directed by the Engineer, the Contractor shall use this equipment to control dust, dirt, and other debris within the project limits and beyond as required, to clean streets surfaces immediately prior to placing HMA pavement mixtures, and for street and utility structure cleaning after any and all paving. The cleaning equipment shall be of sufficient power to remove dust, dirt, and debris from the pavement and from utility structures in and adjacent to the construction area.

d. Measurement and Payment. The Engineer will not pay for the work required of this detailed specification separately. The Contractor shall include it in the contract unit price bid for the pay item **General Conditions, Maximum, \$___**.

CITY OF ANN ARBOR
DETAILED SPECIFICATION
FOR
PROJECT SCHEDULE

AA:DAD

1 of 2

04/17/18

Complete the entirety of work under this Contract in accordance with, and subject to, the scheduling requirements as outlined below, and all other requirements of the Contract Documents.

Organize, coordinate and diligently execute the work at the locations shown on the Schedule of Streets included herein. This schedule details the requirements, if any, for the Start of Work (on or after dates specified), the Completion of Work (on or before dates specified), Restricted Dates, the Maximum Calendar Days for Completion, and the Liquidated Damages per Calendar Day for each street. For the purpose of this Contract, the "Start of Work" definition is the date when either the "No-Parking" signs or the temporary traffic control measures become effective, whichever occurs first and relates only to the application of the designated surface treatment. Pavement repairs and other surface preparation work does not apply. The definition of the "Completion of Work" is the point in time when all work designated for a project location is complete. This includes, but is not limited to, placement of permanent pavement markings, street and underground utility and utility structure cleaning as required, removal of sedimentation and soil erosion control devices, removal of all temporary traffic control devices and "No Parking" signs, and other necessary project clean-up work as directed by the Engineer.

The Engineer shall limit the Contractor's work operations to a number of streets that, in the opinion of the Engineer, is reasonable to allow for proper and thorough inspection, and to reduce traffic control and/or safety problems. The contractor shall not have more than two (2) locations "active" at any given time with a maximum of one (1) of those locations being a Major Street. A location is "active" if work on the street has begun, and it has not yet complete. Regard an "Area" shown on the Schedule of Streets as one (1) location.

The City expects to furnish the Contractor with two (2) copies of the Contract, for its execution, on or before **May 22, 2018**. The Contractor shall properly execute both copies of the Contract and return them, with the required Bonds and Insurance documentation, to the City by **June 8, 2018**. The Contractor shall not begin the work before the applicable date(s) as described herein without approval from the Project Engineer, and in no case before the receipt of the fully executed Contract and Notice to Proceed.

By no later than **June 22, 2018**, the Contractor shall submit a detailed schedule of work (progress schedule) for the Engineer's review and approval. The progress schedule must fully comply with the scheduling requirements contained on the Schedule of Streets. The schedule shall clearly indicate, in detail, the start and the finish date of each work task on each street. The Contractor shall update the approved progress schedule each week, and present it to the Engineer at the weekly progress meeting, and must consult with the Engineer for review and approval of any proposed deviations from the most current, approved, schedule.

The Contractor shall begin project work on or after **July 5, 2018**, and only upon receipt of the fully executed Contract, Notice to Proceed and approved Progress Schedule. The City will consider granting appropriate time extensions should delays prevent the Contractor from starting work on this date.

Complete the entire project on or before **June 30, 2019**. Completion of the project means all locations shown on the Schedule of Streets are complete and ready for use in accordance with the "Completion of Work" as defined above.

Failure to complete all work as specified within the times specified, including time extensions granted thereto as determined by the Engineer, shall entitle the City to deduct dollar amounts specified in the Schedule of Streets as "Liquidated Damages" from the payments due the Contractor. The City will assess "Liquidated Damages" for delays in the completion of the work for each street, for each calendar day the work remains incomplete beyond the required contract completion date.

Time is of the essence in the performance of the work of this contract. The Contractor is expected to mobilize sufficient personnel and equipment and work throughout all authorized hours to complete the project by the intermediate (location specific) and final completion dates. Should the Contractor demonstrate that they must work on some Sundays in order to maintain the project schedule, they may only do so with prior approval from the City, and only during approved working hours. There will be no additional compensation due to the Contractor for work performed on Sundays.

The Engineer may delay or stop the work due to threatening weather conditions. No compensation shall be due the Contractor for unused materials or downtime due to rain, or the threat of rain. The Contractor is solely responsible for repairing all damages to the work and to the site, including any City infrastructure, and any adjacent properties resulting from its decision to work in the rain.

The Contractor shall not work in the dark except as approved by the Engineer and shall provide lighting for night work as detailed elsewhere in this contract. The Engineer may stop the work, or may require the Contractor to defer certain work to another day, if, in the Engineer's opinion, the Contractor cannot be complete the work within the remaining daylight hours, or if inadequate daylight is present to properly perform or inspect the work. No compensation shall be due to the Contractor for unused materials or downtime, when the Engineer directs work stoppage for reasons due to darkness and/or inadequate remaining daylight. The Contractor is solely responsible for repairing all damages to the work and to the site, including any City infrastructure, and any adjacent properties, which result from working in the dark.

Assessment of Liquidated Damages will occur until the required work is complete in the current construction season. If, with the Engineer's approval, work extends beyond seasonal limitations, the assessment of Liquidated Damages will discontinue until the work resumes in the following construction season.

If the construction contract is not complete within the specified period(s) including any extensions of time granted thereto, at the sole discretion of the City of Ann Arbor it may terminate the Contract. Should this occur no additional compensation will be due to the Contractor, and the Contractor may be forbidden to bid on future City of Ann Arbor projects for a period of at least three (3) years. If the Engineer elects to terminate the Contract, payment for contract items with a Lump Sum unit price will be up to a maximum amount equal to the percentage of the contract work that is complete at the time of termination.

The City's decision to delete streets, add streets, change the construction limits on streets, or, the City's contribution to a delay of the construction on any one street shall not entitle the Contractor to receive additional compensation for work on any other street(s), nor shall it relieve the Contractor of any responsibilities for completion of work on any other street(s).

Include any/all to organize, coordinate, and schedule all of the project work in the contract unit price bid for the pay item **General Conditions, Max \$_____**.

Street Surface Treatment Project – FY2019

Project Schedule of Streets

| Location (Street) | Limits of Work | Start of Work | Completion of Work | Restricted Dates | Maximum Calendar Days for Completion | Liquidated Damages per Calendar Day |
|-------------------|---|---------------|--------------------|-------------------------------|--------------------------------------|-------------------------------------|
| Green Road | Plymouth Road to Gettysburg Road/Burbank Drive | | | CAA1, MMRL, UMFB | 15 | \$750.00 |
| Fuller Road | East End of Huron River Bridge to Fuller Court | | | AAAF, LABR, MMRL, UMFB | 15 | \$1,000.00 |
| Area 1 | See Project Location List and Minor (Local) Streets Map | | | AAAF, *AAPS, LABR, MMRL, UMFB | 21 | \$500.00 |
| Area 2 | See Project Location List and Minor (Local) Streets Map | | | AAAF, LABR, MMRL, UMFB | 20 | \$500.00 |
| Area 3 | See Project Location List and Minor (Local) Streets Map | | | LABR, MMRL, UMFB | 7 | \$500.00 |
| Area 4 | See Project Location List and Minor (Local) Streets Map | | | LABR, MMRL, UMFB | 10 | \$500.00 |
| Area 5 | See Project Location List and Minor (Local) Streets Map | | | LABR, MMRL, UMFB | 14 | \$500.00 |

AAAF - No work permitted from July 19, 2018 thru July 22, 2018 due to the Ann Arbor Street Art Fairs.

AAPS - No work permitted when Ann Arbor Public Schools are in session (before June 18, 2018 or after September 3, 2018 until June 17, 2019).
 *This only applies to Lorraine Street in the Area 1 project location.

CAA1 - No work permitted during the City of Ann Arbor Green Road Sidewalk Gap Project (anticipated to start on or after August 20, 2018, and be complete by October 1, 2018).

CAA2 - No work permitted during the City of Ann Arbor Green Road Sidewalk Gap Project (anticipated to start on or after August 20, 2018, and be complete by October 1, 2018).

LABR - No work during the Labor Day holiday period from 3:00 p.m. August 31 to 7:00 a.m. September 4, 2018.

MMRL - No work during the Memorial Day holiday period from 3:00 p.m. May 25 to 7:00 a.m. May 29, 2018.

UMFB - No work permitted during scheduled home game dates for University of Michigan Football.

Notes:

- Upon starting work on the Minor (Local) streets in Areas 1, 2, 3, 4 and/or 5, perform all work in each area until it is complete and before starting work on a new area. The only exception to this requirement applies to Area No. 1 and the work on Lorraine Street, which the Contractor should schedule and perform separately when the Ann Arbor Public Schools are not in session, and only if all other work within this area cannot be performed in that timeframe.

CITY OF ANN ARBOR
DETAILED SPECIFICATION
FOR
MAXIMUM UNIT WEIGHT

AA:DAD

1 of 1

04/17/18

Determination of the maximum dry density per cubic foot (lbs/ft³) will be using test method AASHTO T-180 unless otherwise directed by the Engineer. Use the determined value(s) as the maximum unit weight when measuring the in place compaction or density of soils unless such value(s) are determined by an alternate test method as directed by the Engineer.

CITY OF ANN ARBOR

DETAILED SPECIFICATION
FOR

SOIL EROSION AND SEDIMENTATION CONTROL – INLET FILTER

AA:DAD

1 of 1

04/17/18

a. Description. This work consists of installing and maintaining inlet filters, as shown on the plans, in accordance with section 208 of the Michigan Department of Transportation (MDOT) 2012 Standard Specifications for Construction and. Install filters in existing and proposed inlets to restrict and minimize amounts of sediment entering into the storm sewer system and water courses. The related work includes the installation, maintenance and removal of the filter cloth, cleaning as required during the performance of the project work, removing and disposing of accumulated sediment, and replacement of filters if required by the Engineer to provide a properly working inlet filter and a well-drained site.

b. Materials. The following devices are approved for use as acceptable alternatives:

1. Siltsack Type B, Regular Flow, by ACF Environmental, Inc.
2. Inlet Pro Sediment Bag, Standard Flow, with optional foam deflector by Hanes GeoComponents.
3. Dandy Curb Bag, Dandy Bag, Dandy Curb Sack, Dandy Sack, or Dandy Pop by Dandy Products, Inc.
4. Basin Bag, Regular Flow by CSI Geoturf.

The Contractor shall submit product data sheets and a sample of the filter material used for inlet filters to the Engineer for approval prior to ordering materials.

c. Construction. The Contractor shall install, maintain, clean, and re-install and/or replace inlet filters in accordance with the manufacturer’s specifications and as directed by the Engineer. The Contractor shall dispose of debris off-site.

d. Measurement and Payment. Measure and pay for the completed work, as described, at the contract unit price for the following pay item:

| <u>Pay Item</u> | <u>Pay Unit</u> |
|-------------------------------------|-----------------|
| Erosion Control, Inlet Filter | Each |

Measure **Erosion Control, Inlet Filter** individually in place by unit each and pay for it at the contract unit price, which price includes all costs for labor, equipment and materials necessary to furnish, install, maintain, clean and remove the inlet filter, and to re-install and/or replace the inlet filter as needed.

CITY OF ANN ARBOR
 DETAILED SPECIFICATION
 FOR
HOT MIX ASHALT PAVEMENT REPAIR

AA:DAD

1 of 2

04/18/18

a. Description. This work consists of repairing areas of failed asphalt pavement by cold milling the existing pavement and placing new hot mix asphalt (HMA) material in according to this special provision, as shown on the plans., as directed by the Engineer, and as described herein. Complete pavement repairs in the cold milled surface prior to placement of the first hot mix asphalt paving course.

b. Materials. Provide materials in accordance with subsection 501.02 of the Michigan Department of Transportation (MDOT) 2012 Standard Specifications for Construction and as shown on the special detail.

Use the following mixes for **Hand Patching, Modified:**

| PAY ITEM | HMA MIX | APPLICATION RATE | ESTIMATED THICKNESS | PERFORMANCE GRADE | AWI (min) |
|--|---------|--|--|-------------------|-----------|
| Hand Patching, Modified, Major Streets | 5E3 | Yield may vary with maximum = 330 lb/syd | Thickness may vary with maximum layer = 3.0 inches | PG 64-28 | N/A |
| Hand Patching, Modified, Minor (Local) Streets | LVSP | Yield may vary with maximum = 330 lb/syd | Thickness may vary with maximum layer = 3.0 inches | PG 58-28 | N/A |

Use the respective mixes indicated above for work on Major and Local streets unless the project log notes otherwise, or directed otherwise by the Engineer.

The Performance Grade asphalt binder range for the HMA mixture shall be as noted above.

Apply bond coat material at uniform rate of application a minimum of 0.10 gallons per square yard unless directed otherwise by the Engineer. Before placing the bond coat, thoroughly clean the existing pavement surface. The Contractor shall also thoroughly clean all edges, and joints and cracks to a minimum depth of one inch, with compressed air, vac-all type equipment, or other approved mechanical or hand methods, to remove all dirt, debris, and all foreign material.

c. Construction. Ensure all construction is in accordance with subsection 501.03 of the MDOT 2012 Standard Specifications for Construction with the following modifications and/or additions.

The Engineer will designate repair locations, and delineate them in the field prior to the start of construction.

Cold mill designated repair locations, and place HMA material according to the special detail. Compact HMA patch material in no greater than 3 inch layers to the adjacent pavement surface grade using a machine vibrator or approved roller.

Complete all pavement repair work prior to placement of any chip seal or micro-surfacing.

d. Measurement and Payment. Measure and pay for the completed work, as described, at the respective contract unit prices using the following respective pay items:

| Pay Item | Pay Unit |
|---|-----------------|
| Cold Milling HMA Surface, Modified..... | Square Yard |
| Hand Patching, Modified, Major Streets..... | Ton |
| Hand Patching, Modified, Minor (Local) Streets..... | Ton |

Measure **Cold Milling HMA Surface, Modified** area by the unit square yard and pay for it at the contract unit price, which price includes the cost for all labor, equipment and materials required to remove, load, haul, and dispose of the cold milled material, and cleaning the cold milled pavement. The Engineer will not pay for material picked up by cleaning after cold milling.

Measure **Hand Patching, Modified, Major Streets** weight by the unit ton and pay for it at the contract unit price, which prices includes the cost for all labor, equipment and materials to place HMA, by hand or other methods, and compacting the material. This price also includes furnishing and applying bond coat material.

Measure **Hand Patching, Modified, Minor (Local) Streets** weight by the unit ton and pay for it at the contract unit price, which prices includes the cost for all labor, equipment and materials to place HMA, by hand or other methods, and compacting the material. This price also includes furnishing and applying bond coat material.

CITY OF ANN ARBOR
DETAILED SPECIFICATION
FOR
MICRO-SURFACING

AA:DAD

1 of 2

04/17/18

a. Description. This work consists of preparing existing pavement and providing and placing a micro-surfacing mixture in accordance with section 504 of the Michigan Department of Transportation (MDOT) 2012 Standard Specifications for Construction, as directed by the Engineer, and as described herein.

b. Materials. Provide materials in accordance with subsection 504.02 of the MDOT 2012 Standard Specifications for Construction with the following modification.

1. Add the following to subsection 504.02.A of the MDOT 2012 Standard Specifications for Construction.

A. Screen 2FA fine aggregate used for micro-surfacing at the project site to ensure aggregate being introduced into the micro-surface mixture is not larger than the top size aggregate allowed in the mix design. Screen aggregate directly into the material transport units or micro-surface machine(s). Use aggregate screening unit capable of producing adequate tonnage to maintain project production in accordance with subsection 504.03.

2. Use CSS-1hM asphalt emulsion for micro-surfacing mixtures. The emulsified asphalt must conform to certification procedures described in the MDOT *Materials Quality Assurance Procedures Manual*.

c. Construction. Ensure all construction is in accordance with subsection 504.03 of the MDOT 2012 Standard Specifications for Construction with the following modifications.

1. Add the following to subsection 504.03.C of the MDOT 2012 Standard Specifications for Construction.

A. Use a pick-up sweeper to perform any sweeping required to prepare the existing surface.

2. Add the following to subsection 504.03.D of the MDOT 2012 Standard Specifications for Construction.

A. Take extreme care not to place micro-surface mixture on any concrete curb and gutter.

Conduct nighttime work between the hours of 7:00 p.m. and 6:00 a.m. at the locations shown on the "Project Schedule of Street" and in the "Project Log". The Engineer may allow nighttime work at other locations with seven (7) day notification to the Engineer, and only after authorization by the City.

d. Measurement and Payment. Measure and pay for the completed work, as described, at the respective contract unit prices using the following respective pay items:

| Pay Item | Pay Unit |
|---|-----------------|
| Micro-Surface, Standard | Square Yard |
| Micro-Surface, Single Course | Square Yard |
| Micro-Surface, Single Course, Nighttime Work..... | Square Yard |

Measure **Micro-Surface, Standard**; **Micro-Surface, Single Course**; and **Micro-Surface, Single Course, Nighttime Work** area in place by their respective units square yard and pay for them at their respective contract unit prices, which prices include the costs for all labor, equipment and materials necessary to complete the work.

The unit prices for **Micro-Surface**, regardless of the type required, include the cost of surface preparation; applying a bond coat; stationing and the establishment of yield intervals; placing temporary pavement markings; corrective action and any traffic control related to it; any required materials sampling and testing; and documentation.

The unit price for **Micro-Surface, Standard** also includes the cost for all materials, equipment, and labor required to place the micro-surfacing mixtures including the application of a rut filling course, a leveling course, and a surface course for full width coverage.

The unit price for **Micro Surface, Single Course** also includes the cost for all materials, equipment, and labor required to place the micro-surfacing mixtures by applying a single course of mixture for full width coverage.

The unit price for **Micro Surface, Single Course, Nighttime Work** also includes the cost for all materials, equipment, and labor required to place the micro-surfacing mixtures by applying a single course of mixture for full width coverage during the hours of work specified. Pay for lighting to conduct this work separately at the contract unit price for the pay item **Ltg for Night Work**.

The City will pay separately for temporary traffic control to place any mixture in accordance with the Detailed Specification for Maintaining Traffic, and removing pavement markings in accordance with subsection 812.04 of the MDOT 2012 Standard Specifications for Construction.

CITY OF ANN ARBOR
DETAILED SPECIFICATION
FOR
CHIP SEAL

AA:DAD

1 of 3

04/17/18

a. Description. This work consists of preparing the pavement surface and providing and placing a single chip seal in accordance with section 505 of the Michigan Department of Transportation (MDOT) 2012 Standard Specifications for Construction, as directed by the Engineer, and as described herein.

b. Materials. Provide materials in accordance with subsection 505.02 of the MDOT 2012 Standard Specifications for Construction with the following modifications.

1. Asphalt Emulsion. Use CRS-2M as specified in section 904 of the MDOT 2012 Standard Specifications for Construction. The emulsified asphalt must conform to certification procedures described in the MDOT *Materials Quality Assurance Procedures Manual*.

2. Coarse Aggregate. Provide CS-2 course aggregates meeting the gradation and physical requirements of Table 1. Coarse aggregates for all chip seals will be tested materials or provided by a prequalified aggregate supplier. Use no copper smelter slag as a chip seal aggregate.

c. Construction. Ensure all construction is in accordance with subsection 505.03 of the MDOT 2012 Standard Specifications for Construction with the following modifications and/or additions.

1. Placement Operation. Prior to placing the chip seal, establish, identify, and maintain, 1,000-foot intervals until project completion.

Immediately prior to placing the chip seal remove all pavement markings using an abrasion method.

Roll the coarse aggregate before the asphalt emulsion has set. Leave no more than 150 feet of unrolled cover material at any time. Leave no cover material unrolled for more than five (5) minutes. Complete a minimum of two (2) complete rolling trips over the cover aggregate. A complete trip is one pass, forward and backward, over the same patch. Each trip shall overlap the previous trip.

Roll the coarse aggregate sufficiently to embed it into the asphalt emulsion. If the Engineer determines that the rolling procedures are not sufficiently embedding the aggregate into the emulsion, then the Contractor will submit modifications for improving the rolling procedures to the Engineer for approval.

Do not place cover (course) aggregate on asphalt emulsion after it breaks.

Perform an initial sweeping on the final surface before the end of each day's work or within 24 hours of application with the approval of the Engineer. Begin initial sweeping within 3 hours after application unless otherwise directed by the Engineer.

2. Application Rates. Apply asphalt emulsion at a rate within the range of 0.39 - 0.41 gallons per square yard. The JMF target rate for the asphalt shall be 0.40 gallons per square yard. Apply asphalt emulsion at a minimum temperature of 290°F, followed by a uniform application of coarse aggregate.

Place CS-2 coarse aggregate at a rate within the range of 18-20 pounds per square yard. The JMF target rate for the asphalt shall be 19 pounds per square yard.

If the target rates are not the optimum application rates due to the gradation of the coarse aggregate or due to existing surface conditions of the pavement, the Contractor shall notify the Engineer. The Contractor shall then submit new rates and a new JMF for approval by the Engineer prior to work commencing.

3. Temporary Raised Pavement Markings. Place temporary raised pavement markings prior to the application of the chip seal, at intervals specified below, or as directed by the Engineer.

- A. On tangent sections of roadway and on gentle curvatures of roadways, place the markers at 50-foot intervals.
- B. On severe curvatures of roadways, place the markers at 25-foot intervals.

Install temporary raised pavement markings no more than 24 hours prior to the placement of the chip seal. Offset the markings from the centerline or lane line(s) to facilitate placement of the first pass of the micro-surfacing; remove the markings under the lane closure of the adjacent pass, and place the temporary pavement markings upon completion of the micro-surfacing to ensure they are always present.

d. Measurement and Payment. Measure and pay for the completed work, as described, at the contract unit price using the following pay item:

| Pay Item | Pay Unit |
|-----------------------------------|-----------------|
| Seal, Single Chip, Modified | Square Yard |

Measure **Seal, Single Chip, Modified** area in place by the unit square yard and pay for it at the contract unit price, which price includes all cost for labor, equipment and materials necessary to complete the work. Payment also includes the cost of surface preparation; placing temporary pavement markings; corrective action and any traffic control related to it; any required materials sampling and testing; and documentation.

The City will pay separately for temporary traffic control in accordance with the Detailed Specification for Maintaining Traffic, and removing pavement markings in accordance with subsection 812.04 of the MDOT 2012 Standard Specifications for Construction.

Table 1: Gradation and Physical Requirements for Single Chip Seal Aggregates

| Sieve Analysis (MTM 109), Total Percent Passing (a) | | |
|--|---------------------------------------|------------------------------------|
| Sieve Size | CS-2 | |
| ¾ " | 100 | |
| ½ " | 100 | |
| 3/8 " | 90-100 | |
| No. 4 | 0-10 | |
| No. 8 | 0-5 | |
| No. 200 (loss by wash) | 2.0 maximum | |
| Physical Requirements for Coarse Aggregates (CS-1 and CS-2) | | |
| Test | Description | Specification |
| MTM 102 | L.A. Abrasion Resistance | 35% maximum (b) 45% maximum (c) |
| MTM 117 | Percent of crushed Particles | 95% minimum |
| MTM 110 | Deleterious Particles in Aggregate | 3.5% maximum (d) |
| ASTM D4791 (e) | Flat and Elongated Ratio, 3:1 | 12.0% maximum |
| MTM 111 (f) | Aggregate Wear Index (AWI) | 260 minimum |
| (g) | Moisture Content at time of Placement | 4% maximum |
| <p>a. All aggregate shall be washed.</p> <p>b. Natural aggregate.</p> <p>c. Iron Blast-Furnace slag aggregate.</p> <p>d. Includes the sum of shale, silt stone, structurally weak and clay ironstone.</p> <p>e. As determined for material retained on the No.4 sieve. The ratio between any combination of length, width or thickness.</p> <p>f. For single chip seal and second course of double chip seal. Does not apply to a shoulder chip seal.</p> <p>g. As described in MDOT Procedures for Aggregate Inspection.</p> <p>Note: The AWI requirement is waived on shoulders.</p> | | |

CITY OF ANN ARBOR
DETAILED SPECIFICATION
FOR
SLURRY SEAL

AA:DAD

1 of 2

04/17/18

a. Description. This work consists of preparing the pavement surface and providing and placing a slurry seal in accordance with section 506 of the Michigan Department of Transportation (MDOT) 2012 Standard Specifications for Construction, as directed by the Engineer, and as described herein.

b. Materials. Provide materials in accordance with subsection 506.02 of the MDOT 2012 Standard Specifications for Construction with the following modifications.

1. Asphalt Emulsion. Use a blend of polymerized asphalt emulsion that is a quick traffic, quick cure (QT-QC) type, and is a homogeneous brown color and shows no separation after thorough mixing that breaks and sets on the aggregate with five (5) minutes and is ready for cross-traffic within fifteen (15) to forty-five (45) minutes. The emulsified asphalt must conform to certification procedures described in the MDOT *Materials Quality Assurance Procedures Manual*.

2. Fine Aggregate. Screen 2FA fine aggregate at the project site to ensure the aggregate being introduced into the slurry seal mixture is not larger than the top size aggregate allowed in the mix design. Screen aggregate directly into the material transport units or slurry seal machine(s). Use aggregate screening unit capable of producing adequate tonnage to maintain project production in accordance with subsection 506.03.

c. Construction. Ensure all construction is in accordance with subsection 506.03 of the MDOT 2012 Standard Specifications for Construction with the following modifications.

1. Add the following to subsection 504.03.C of the MDOT 2012 Standard Specifications for Construction.

A. Remove pavement markings using an abrasion method.

B. Use a pick-up sweeper to perform any sweeping required to prepare the existing surface.

C. Protect drainage and utility structures, monument and valve boxes, and other existing structures during bond coat and mixture application.

D. Prior to placing the mixture, establish, identify, and maintain, 1,000-foot intervals until project completion.

1. Delete subsection 506.03.D of the MDOT 2012 Standard Specifications for Construction and replace with the following.

A. Application. Apply a single course of slurry seal over the entire existing HMA surface area at a rate of 24 pounds per square yard \pm 2 pounds per square yard, based on the weight of the dry aggregate, including the shoulder(s) if required.

Document any approved changes to a new/revised JMF rate by stationing.

- B. Take extreme care not to place slurry seal mixture on any concrete curb and gutter.

d. Measurement and Payment. Measure and pay for the completed work, as described, at the contract unit price using the following pay item:

| Pay Item | Pay Unit |
|------------------------------|-----------------|
| Seal, Slurry, Modified | Square Yard |

Measure **Seal, Slurry, Modified** area in place by the unit square yard and pay for it at the contract unit price, which price includes all cost for labor, equipment and materials necessary to complete the work for placement of a single course of slurry seal to a pavement and the accompanying shoulder(s). Payment also includes surface preparation; applying a bond coat; stationing and the establishment of yield intervals; corrective action and all traffic control related to it; any required materials sampling and testing; and documentation.

The City will pay separately for temporary traffic control required to place the mixture in accordance with the Detailed Specification for Maintaining Traffic, and removing pavement markings in accordance with subsection 812.04 of the MDOT 2012 Standard Specifications for Construction.

CITY OF ANN ARBOR
 DETAILED SPECIFICATION
 FOR
PERMANENT PAVEMENT MARKINGS

AA:DAD

1 of 1

04/17/18

a. Description. This work consists of providing and placing permanent pavement markings in accordance with the Michigan Manual on Uniform Traffic Control Devices (MMUTCD). Provide pavement markings that conform to the plans, section 811 of the Michigan Department of Transportation (MDOT) 2012 Standard Specifications for Construction, MDOT Pavement Marking Standard Plans, City of Ann Arbor Special Details, as directed by the Engineer, and as specified herein.

b. Materials. Provide materials in accordance with sections 811 and 920 of the MDOT 2012 Standard Specifications for Construction. Provide the Material Safety Data Sheets to the Engineer for required materials and supplies. Dispose of unused material and containers in accordance with the Federal Resource Conservation Recovery Act (RCRA) of 1976 as amended, and 1994 PA 451, Part 111 Hazardous Waste Management. Provide samples of permanent pavement marking materials upon request.

c. Construction Methods. The preparation and placement of permanent pavement markings shall conform to section 811 of the MDOT 2012 Standard Specifications, the plans, and as specified herein.

d. Measurement and Payment. Measure and pay for the completed work, as described, at the respective contract unit prices using the following respective pay items:

| <u>Pay Item</u> | <u>Pay Unit</u> |
|---|-----------------|
| Pavt Mrkg, Thermopl, 4 inch, Parking Sym, White..... | Foot |
| Pavt Mrkg, Thermopl, Lt Turn Arrow Sym | Each |
| Pavt Mrkg, Thermopl, Rt Turn Arrow Sym | Each |
| Pavt Mrkg, Thermopl, Thru Arrow Sym | Each |
| Pavt Mrkg, Thermopl, Thru and Lt Turn Arrow Sym..... | Each |
| Pavt Mrkg, Thermopl, Thru and Rt Turn Arrow Sym | Each |
| Pavt Mrkg, Thermopl, Only..... | Each |
| Pavt Mrkg, Thermopl, Railroad Sym | Each |
| Pavt Mrkg, Thermopl, School..... | Each |
| Pavt Mrkg, Thermopl, Speed Hump Chevron, White | Each |

Measure **Pavt Mrkg, Thermopl, Lt Turn Arrow Sym; Pavt Mrkg, Thermopl, Only; Pavt Mrkg, Thermopl, Rt Turn Arrow Sym; Pavt Mrkg, Thermopl, Speed Hump Chevron, White; and Pavt Mrkg, Thermopl, Thru Arrow Sym** individually in place by the unit each and pay for them at their respective contract unit prices, which prices include the costs for all labor, equipment and materials to complete the work.

CITY OF ANN ARBOR
DETAILED SPECIFICATION
FOR
MAINTENANCE OF TRAFFIC

AA:DAD

1 of 5

04/18/18

a. Description. The Contractor shall maintain traffic at the locations identified on the “Schedule of Streets” for duration of project work. Maintenance of traffic will be in accordance with subsection 104.11 and section 812 of the Michigan Department of Transportation (MDOT) 2012 Standard Specifications for Construction, the 2011 Michigan Manual of Uniform Traffic Control Devices (MMUTCD), applicable supplemental specifications, as directed by the Engineer, and as herein specified.

All streets included in this project shall remain open to traffic during construction unless otherwise approved by the Engineer.

The Contractor shall maintain traffic in accordance with the following, and herein included, Michigan Department of Transportation (MDOT) Maintaining Traffic Typical and Work Zone Device Details apply to the project: M0020a, M0050a, M0140a, M0150a, M0232a, M0250a, M0280a, M0310a, M0330a, M0350a, M0380a, M0400a, WZD-100-A, and WZD-125-E.

The Contractor must submit a work zone traffic control plan to the Engineer in accordance with section 104 of the 2012 Standard Specifications for Construction and this detailed specification. The Engineer will have seven (7) calendar days to review the plan for acceptance or provide comments for plan revisions required to obtain acceptance. At a minimum, the plan shall include the proposed ingress/egress locations for construction equipment and vehicles, traffic control devices that will be utilized to warn the motoring public of ingress/egress locations, and measures that will be taken to ensure compliance with the plan. No work shall begin prior to acceptance of the work zone traffic control plan. Additional time required to obtain an accepted work zone traffic control plan shall not be cause for delay or impact claims. All costs associated with obtaining an acceptable plan, providing and executing all parts of the accepted plan including required traffic control devices, or resolving an incomplete or unacceptable plan shall be borne by the Contractor.

The Engineer will direct any changes or adjustments to these signing typicals and details as may be necessary to facilitate the maintenance of traffic required for the project.

The permanent pavement marking items are included in the contract and shall be placed per the MDOT 2012 Standard Specifications for Construction prior to the removal of any devices required to temporarily maintain traffic during construction, and also prior to opening the project to traffic unless otherwise approved by the Engineer.

The Contractor shall notify the Project Engineer a minimum of 10 business days prior to the implementation of any lane closures.

These maintaining traffic provisions are subject to change in the event of special community activities.

b. Materials. Materials for all devices used to temporarily control and maintain traffic shall meet the requirements of section 812 of the MDOT 2012 Standard Specifications for Construction, the MMUTCD, and the applicable MDOT typicals and details included herein.

All signs shall be of sizes shown on the MDOT typicals and details, unless otherwise directed by the Engineer. Install temporary signs that are to remain in the same place for 14 days or more on driven posts. Install all other temporary signs on portable supports. All signs shall have a minimum bottom height of 7.0 feet.

Channelizing devices required for all lane closures shall be plastic drums. 42 inch channelizing devices are permissible at certain locations with approval from the Engineer.

c. Construction. Construction methods shall meet the requirements of section 812 of the MDOT 2012 Standard Specifications for Construction.

The Contractor shall furnish and place all necessary temporary traffic control devices to maintain traffic during construction. Keep all work, construction equipment, and material storage behind the curb, or behind barricades or channelizing devices, in combination with protective fencing if required to protect open excavations. No work, construction equipment, or material storage shall in any way hinder vehicle movement or impair traffic vision. The contractor shall protect all uncured surface treatment applications as required until all traffic (pedestrian, bicycle, vehicular, etc.) can access it without damage. The Contractor shall install additional barricades and protective fencing at the end of each day to insure no disturbance to the work area.

Distances between warning, regulatory, and guide signs as shown on the typicals and details are approximate, and may require field adjustment, as directed by the Engineer.

The Contractor shall maintain two-way traffic as shown on the typicals and details, access for local traffic on local streets, and keep all intersections open to traffic at all times, unless specifically authorized in writing by the Engineer.

The Contractor shall maintain traffic such that no vehicle shall be required to drive into active work areas. Remove and replace patch areas that extend more than halfway across the roadway in a manner to provide a minimum of half the pavement width at all times for maintaining traffic.

The Contractor shall remove existing pavement markings and place temporary pavement markings as directed by the Engineer.

All temporary traffic/pedestrian control devices furnished by the Contractor shall remain the property of the Contractor. The City shall not be responsible for stolen or damaged signs, barricades, plastic drums and other traffic maintenance items. The Contractor shall replace missing and/or damaged traffic control devices immediately, at no additional cost to the City.

1. Construction Influence Area (CIA). The CIA shall consist of, at each location, the width of the right-of-way and easements, and the limits of any advance temporary construction signing shown on the applicable maintaining traffic typicals and details along the street under construction and any/all cross streets. Posted detour routes are not included as part of the CIA.

The Contractor shall furnish, erect, maintain, and upon completion of the work, remove all traffic control devices within and around the CIA, and along posted detour routes, for the safety and protection of traffic. This includes, but is not limited to, regulatory and

warning signs, barricades, channeling devices and other minor devices where required by the Engineer.

The Contractor shall coordinate its operations with all subcontractors, utilities, and/or other contractors performing work on this and other projects within, or adjacent to, the Construction Influence Area (CIA). The contractor shall avoid conflicts in maintaining traffic operations, signing, and orderly progress of other contract work.

2. Permits. Prior to the start of construction, the Contractor shall obtain a "Right-of-Way" Permit from City of Ann Arbor Customer Services Unit. The Contractor shall notify the Engineer and obtain a "Traffic Detour or Lane Closure" Permit from City of Ann Arbor Project Management Services Unit a minimum of 72 business hours prior to the implementation of any traffic shifts, lane closures and street closures. The City will waive the fees associated with these permits.

3. Work Times and Restrictions. Conduct all work Monday through Saturday between 7:00 a.m. and 8:00 p.m. unless there is plan authorized by the City prior to commencement of construction that identifies the alternate days and hours of work. Notify the Engineer a minimum of three (3) working days in advance of any required night work. Night work must have the approval of the City prior to commencement.

Only perform work on Sunday if it is of an emergency nature or if it is necessary to ensure vehicular and pedestrian traffic safety, and only perform it with prior approval by the City.

Perform no construction activities or interruptions to traffic, including lane closures, on Sundays and during the Memorial Day, Independence Day, and Labor Day holiday periods unless otherwise authorized by the Engineer. All streets and sidewalks that can be open shall be open to motorized and non-motorized traffic. The Engineer will also not permit any trucking on or off site during these times.

During non-working periods, any area with uncompleted work shall have plastic drums at specific locations and protective fencing, as directed by the Engineer, and at no additional cost to the project.

4. Traffic Restrictions. The Contractor shall, at all times, conduct its work to insure the least possible obstruction to traffic and inconvenience to the general public, businesses, and residents in the vicinity of the work.

Do not impact traffic on major streets between the hours of 7:00 a.m. to 9:00 a.m. and from 3:30 p.m. to 6:00 p.m. unless otherwise approved by the Engineer or as specified on the Lane Closure Permit. Make all major changes in traffic control either between 9:00 a.m. and 3:30 p.m. or between 6:00 p.m. and 7:00 a.m. in order to minimize interference with rush hour traffic. All traffic controls must be in place and ready for traffic each day by 7:00 a.m. and 3:30 p.m. The Engineer will permit temporary obstruction of traffic for loading and unloading of trucks if the Contractor provides traffic regulators (flag persons) in conformance with Part VI of the MMUTCD. During temporary obstructions, a minimum of two traffic regulators are required.

Maintain access to businesses, residences, and side street(s) within the CIA for the duration of the project. The Contractor shall make every effort to coordinate its

operations to minimize interruptions that may impact this access. The Contractor shall notify the Engineer forty-eight (48) hours in advance of any work planned on or near business or residential driveways, and stage work so that it is part-width when it is necessary to work in these areas. The Engineer will not allow the Contractor to prohibit access to businesses and residences during any phase of construction, unless agreed upon with the property owner(s). The Engineer may require traffic regulator (flag) control at its discretion, and will direct the Contractor to provide it when necessary to maintain safe access to businesses, residences, and side street(s).

Lane width shall be a minimum of 9 feet wide. Contractor shall schedule work in order to maintain traffic flow and under no circumstances stop traffic for prolonged periods as determined by the Engineer. The Contractor shall suspend work within the CIA during peak traffic hours and/or when construction activities are unduly hampering or delaying traffic flow as determined by the Engineer.

5. Emergency Services. The Contractor shall notify local police, fire departments and emergency response units a minimum of three business days (72 hours) prior to the closure of any lanes, or traffic shifts causing restricted movements of traffic or restricted access. Fire hydrants in or adjacent to the work shall be kept "live" and fire fighting forces made aware of their availability at all times during construction.

d. Measurement and Payment. Measure and pay for the completed work, as described, for the maintenance of traffic using the following pay items in accordance with subsection 812.04 of the MDOT 2012 Standard Specifications for Construction and any detailed specifications or special provisions included in the Contract.

| <u>Pay Item</u> | <u>Pay Unit</u> |
|--|-----------------|
| Barricade, Type III, High Intensity, Double Sided, Lighted, Furn | Each |
| Barricade, Type III, High Intensity, Double Sided, Lighted, Oper | Each |
| Channelizing Device, 42 inch, Furn | Each |
| Channelizing Device, 42 inch, Oper | Each |
| Lighted Arrow, Type C, Furn | Each |
| Lighted Arrow, Type C, Oper | Each |
| Pavt Mrkg, Longit, 6 inch or Less Width, Rem | Foot |
| Pavt Mrkg, Longit, Greater than 6 inch Width, Rem | Foot |
| Pavt Mrkg, Wet Retrflc, Type NR, Paint, 4 inch, White, Temp | Foot |
| Pavt Mrkg, Wet Retrflc, Type NR, Paint, 4 inch, Yellow, Temp | Foot |
| Plastic Drum, High Intensity, Furn | Each |
| Plastic Drum, High Intensity, Oper | Each |
| Raised Pavt Marker, Temp, Type 1, White, Monodirectional | Each |
| Raised Pavt Marker, Temp, Type 1, Yellow, Bidirectional | Each |
| Sign Cover | Each |
| Sign, Portable, Changeable Message, Furn | Each |

| | |
|---|-------------|
| Sign, Portable, Changeable Message, Oper..... | Each |
| Sign, Type B, Temp, Prismatic, Furn | Square Foot |
| Sign, Type B, Temp, Prismatic, Oper..... | Square Foot |
| Traf Regulator Control..... | Lump Sum |
| _Pedestrian Type II Barricade, Temp | Each |
| _Minor Traffic Control, Max \$____ | Lump Sum |

All signing and related traffic control devices deemed necessary for the maintenance of traffic on the project as shown on the applicable MDOT Maintaining Traffic Typical and Work Zone Device Details are the basis for the estimated quantities contained in the Contract, including traffic regulators, lighted arrows and minor traffic control devices.

Payment for furnishing and operating temporary traffic control devices shall be for the maximum quantity in use at each location at any one time with exception to lighted arrows and portable changeable message signs, which payment shall be for furnishing and operating the maximum quantity in use at any one time during the entire project (all streets).

Any additional signing or maintaining traffic devices required to expedite the construction shall be at the Contractor's expense unless approved by the Engineer.

Include any/all costs for transporting temporary traffic control devices in their respective contract unit prices bid for the individual traffic control items of work set up in the contract.

The Engineer will pay for temporary traffic control devices only once irrespective of the number of times moved or placed in and out of operation.

Include any/all costs for temporary traffic control devices where there is no separate pay item in the contract unit price bid for the pay item **_Minor Traffic Control, Max \$____**.

MINIMUM MERGING TAPER LENGTH "L" (FEET)

| OFFSET FEET | POSTED SPEED LIMIT, MPH (PRIOR TO WORK AREA) | | | | | | | | | |
|----------------|--|-----|-----|-----|-----|-----|-----|-----|-----|------|
| | 25 | 30 | 35 | 40 | 45 | 50 | 55 | 60 | 65 | 70 |
| 1 | 10 | 15 | 20 | 27 | 45 | 50 | 55 | 60 | 65 | 70 |
| 2 | 21 | 30 | 41 | 53 | 90 | 100 | 110 | 120 | 130 | 140 |
| 3 | 31 | 45 | 61 | 80 | 135 | 150 | 165 | 180 | 195 | 210 |
| 4 | 42 | 60 | 82 | 107 | 180 | 200 | 220 | 240 | 260 | 280 |
| 5 | 52 | 75 | 102 | 133 | 225 | 250 | 275 | 300 | 325 | 350 |
| 6 | 63 | 90 | 123 | 160 | 270 | 300 | 330 | 360 | 390 | 420 |
| 7 | 73 | 105 | 143 | 187 | 315 | 350 | 385 | 420 | 455 | 490 |
| 8 | 83 | 120 | 163 | 213 | 360 | 400 | 440 | 480 | 520 | 560 |
| 9 | 94 | 135 | 184 | 240 | 405 | 450 | 495 | 540 | 585 | 630 |
| 10 | 104 | 150 | 204 | 267 | 450 | 500 | 550 | 600 | 650 | 700 |
| 11 | 115 | 165 | 225 | 293 | 495 | 550 | 605 | 660 | 715 | 770 |
| 12 | 125 | 180 | 245 | 320 | 540 | 600 | 660 | 720 | 780 | 840 |
| 13 | 135 | 195 | 266 | 347 | 585 | 650 | 715 | 780 | 845 | 910 |
| 14 | 146 | 210 | 286 | 374 | 630 | 700 | 770 | 840 | 910 | 980 |
| 15 | 157 | 225 | 307 | 400 | 675 | 750 | 825 | 900 | 975 | 1050 |

TAPER LENGTH "L" IN FEET

THE FORMULAS FOR THE MINIMUM LENGTH OF A MERGING TAPER IN DERIVING THE "L" VALUES SHOWN IN THE ABOVE TABLES ARE AS FOLLOWS:

"L" = $\frac{W \times S^2}{60}$ WHERE POSTED SPEED PRIOR TO THE WORK AREA IS 40 MPH OR LESS

"L" = S x W WHERE POSTED SPEED PRIOR TO THE WORK AREA IS 45 MPH OR GREATER

- L = MINIMUM LENGTH OF MERGING TAPER
- S = POSTED SPEED LIMIT IN MPH PRIOR TO WORK AREA
- W = WIDTH OF OFFSET

TYPES OF TAPERS

UPSTREAM TAPERS

- MERGING TAPER
- SHIFTING TAPER
- SHOULDER TAPER
- TWO-WAY TRAFFIC TAPER

DOWNSTREAM TAPERS (USE IS OPTIONAL)

TAPER LENGTH

- L - MINIMUM
- 1/2 L - MINIMUM
- 1/3 L - MINIMUM
- 100' - MAXIMUM
- 100' - MINIMUM (PER LANE)

| | | | |
|---|---|-------------------------|--------|
|  TRAFFIC AND SAFETY MAINTAINING TRAFFIC TYPICAL | TABLES FOR "L", "D" AND "B" VALUES | | |
| | DRAWN BY: CON:AE:djf CHECKED BY: BMM | JUNE 2006 PLAN DATE: | M0020a |
| FILE: K:/DGN/TSR/STDS/ENGLISH/MNTTRF/M0020a.dgn REV. 08/21/2006 | | | |

DISTANCE BETWEEN TRAFFIC CONTROL DEVICES "D"
AND LENGTH OF LONGITUDINAL BUFFER SPACE ON
"WHERE WORKERS PRESENT" SEQUENCES

| "D" DISTANCES | POSTED SPEED LIMIT, MPH (PRIOR TO WORK AREA) | | | | | | | | | |
|------------------|--|-----|-----|-----|-----|-----|-----|-----|-----|-----|
| | 25 | 30 | 35 | 40 | 45 | 50 | 55 | 60 | 65 | 70 |
| D (FEET) | 250 | 300 | 350 | 400 | 450 | 500 | 550 | 600 | 650 | 700 |

GUIDELINES FOR LENGTH OF
LONGITUDINAL BUFFER SPACE "B"

| SPEED* MPH | LENGTH FEET |
|---------------|----------------|
| 20 | 33 |
| 25 | 50 |
| 30 | 83 |
| 35 | 132 |
| 40 | 181 |
| 45 | 230 |
| 50 | 279 |
| 55 | 329 |
| 60 | 411 |
| 65 | 476 |
| 70 | 542 |

* POSTED SPEED, OFF PEAK 85TH PERCENTILE SPEED PRIOR TO WORK STARTING, OR THE ANTICIPATED OPERATING SPEED

1 BASED UPON AMERICAN ASSOCIATION OF STATE HIGHWAY AND TRANSPORTATION OFFICIALS (AASHTO) BRAKING DISTANCE PORTION OF STOPPING SIGHT DISTANCE FOR WET AND LEVEL PAVEMENTS (A POLICY ON GEOMETRIC DESIGN OF HIGHWAY AND STREETS), AASHTO. THIS AASHTO DOCUMENT ALSO RECOMMENDS ADJUSTMENTS FOR THE EFFECT OF GRADE ON STOPPING AND VARIATION FOR TRUCKS.

| | | | |
|---|---|-------------------------|--------|
|  TRAFFIC AND SAFETY MAINTAINING TRAFFIC TYPICAL | TABLES FOR "L", "D" AND "B" VALUES | | |
| | DRAWN BY: CON:AE:djf CHECKED BY: BMM | JUNE 2006 PLAN DATE: | M0020a |
| FILE: K:/DGN/TSR/STDS/ENGLISH/MNTTRF/M0020a.dgn REV. 08/21/2006 | | | |

SIGN PLACEMENT
IS THE SAME FOR
BOTH DIRECTIONS

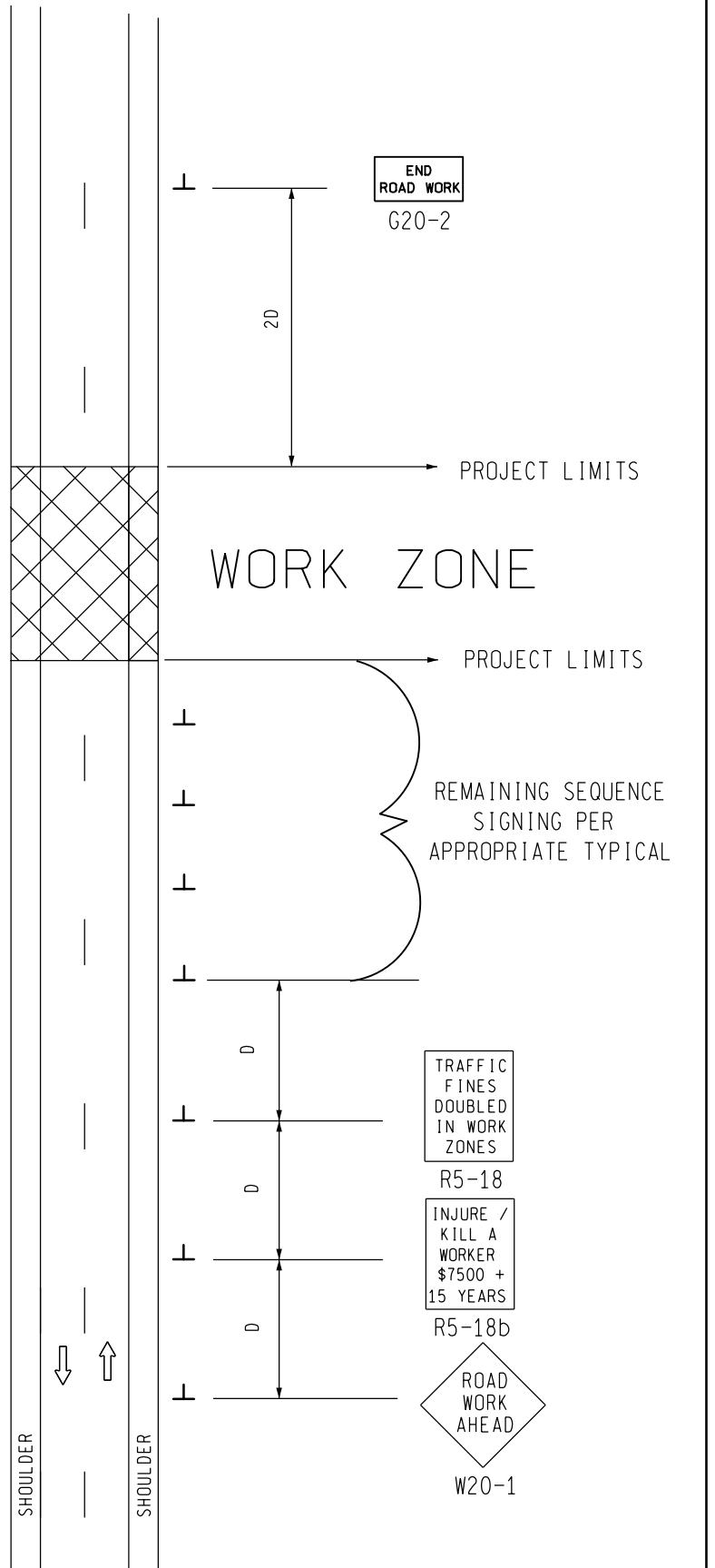
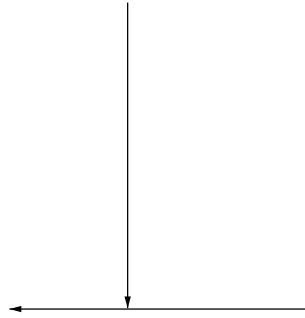

SIGN = 48 f+2 - TYPE B
FOR ONE DIRECTION OF TRAFFIC
W20-1 QUANTITY INCLUDED WITH
APPROPRIATE TYPICAL FOR
SEQUENCE SIGNING

| | | |
|--|--|------------------------------------|
| <p>TRAFFIC AND SAFETY MAINTAINING TRAFFIC TYPICAL</p> | <p>TYPICAL ADVANCE SIGNING TREATMENT FOR INTERMEDIATE AND SHORT TERM STATIONARY WORK ZONE OPERATIONS WHERE ALL TRAFFIC CONTROL DEVICES ARE REMOVED AT END OF EACH WORK DAY ON AN UNDIVIDED TWO-WAY ROADWAY</p> | |
| | <p>DRAWN BY: CON:AE:djf CHECKED BY: BMM:CRB</p> | <p>OCTOBER 2011 PLAN DATE:</p> |
| <p>FILE: PW_RD/TS/Typicals/Signs/MT NON FWY/M0050a.dgn REV. 10/13/2011</p> | | |

NOT TO SCALE

NOTES

30. THE APPROPRIATE ADVANCE SIGNING SEQUENCE(S), (M0030a THROUGH M0080a) SHALL BE USED ON ALL PROJECTS.
35. THESE SIGNS ARE INTENDED TO BE USED WITHIN THE LIMITS OF THE TEMPORARY SEQUENCE SIGNING AS IS SHOWN ON 1 OF 2. THESE SIGNS ARE NOT TO BE INTERMINGLED WITH ANY OTHER TEMPORARY SEQUENCE SIGNING EXCEPT AS SHOWN.

SIGN SIZES

| | | |
|--------|---|-----------|
| G20-2 | - | 48" x 24" |
| R5-18 | - | 48" x 60" |
| R5-18b | - | 48" x 60" |
| W20-1 | - | 48" x 48" |

| | | | |
|---|--|--------------|--------|
|  TRAFFIC AND SAFETY MAINTAINING TRAFFIC TYPICAL | TYPICAL ADVANCE SIGNING TREATMENT FOR INTERMEDIATE AND SHORT TERM STATIONARY WORK ZONE OPERATIONS WHERE ALL TRAFFIC CONTROL DEVICES ARE REMOVED AT END OF EACH WORK DAY ON AN UNDIVIDED TWO-WAY ROADWAY | | |
| | DRAWN BY: CON:AE:djf | OCTOBER 2011 | SHEET |
| CHECKED BY: BMM:CRB | PLAN DATE: | M0050a | 2 OF 2 |
| FILE: PW_RD/TS/Typicals/Signs/MT NON FWY/M0050a.dgn REV. 10/13/2011 | | | |

NOT TO SCALE





PLACE THROUGHOUT WORK AREA AS INDICATED AND AFTER ALL MAJOR CROSSROADS IF PERMANENT SIGNS ARE NOT IN PLACE.

PLACE THIS SIGN ALONG WITH THE ADVANCE WORK ZONE SIGNING AS DEPICTED ON THE APPROPRIATE TYPICAL M0030a-M0080a.

PLACE THROUGHOUT WORK AREA AS INDICATED AND AFTER ALL MAJOR CROSSROADS IF PERMANENT SIGNS ARE NOT IN PLACE.

PLACE THIS SIGN ALONG WITH THE ADVANCE WORK ZONE SIGNING AS DEPICTED ON THE APPROPRIATE TYPICAL M0030a-M0080a.

KEY

-  TRAFFIC REGULATOR
-  CHANNELIZING DEVICES
-  LIGHTED ARROW PANEL (CAUTION MODE)
-  TRAFFIC FLOW
-  REFLECTS EXISTING SPEED LIMIT

SIGN = 200 ft± - TYPE B PLUS ADDITIONAL R2-1's THROUGHOUT WORK AREA

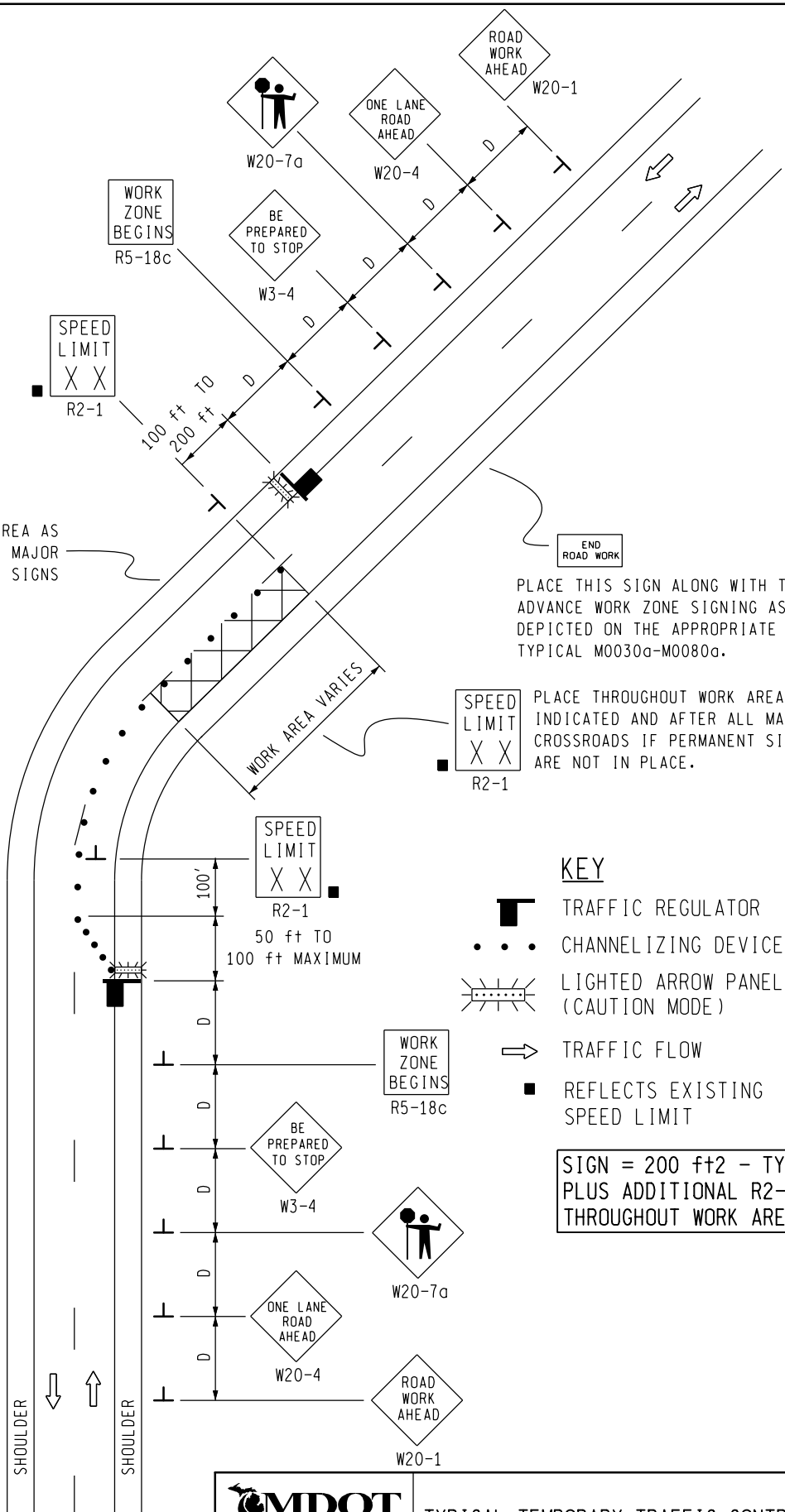

TRAFFIC AND SAFETY
MAINTAINING TRAFFIC
TYPICAL

TYPICAL TEMPORARY TRAFFIC CONTROL FOR
A TWO-LANE TWO-WAY ROADWAY WHERE ONE
LANE IS CLOSED UTILIZING TRAFFIC
REGULATORS, NO SPEED REDUCTION

DRAWN BY: CON:AE:djf
CHECKED BY: BMM:CRB

OCTOBER 2011
PLAN DATE:

M0140a

SHEET
1 OF 2

NOT TO SCALE

FILE: PW_RD/TS/Typicals/Signs/MT NON FWY/M0140a.dgn REV. 10/04/2011

NOTES

- 1H. D = DISTANCE BETWEEN TRAFFIC CONTROL DEVICES AND LENGTH OF LONGITUDINAL BUFFERS
SEE **M0020a** FOR "D" VALUES.
2. ALL NON-APPLICABLE SIGNING WITHIN THE CIA SHALL BE MODIFIED TO FIT CONDITIONS, COVERED OR REMOVED.
3. DISTANCES BETWEEN SIGNS, THE VALUES FOR WHICH ARE SHOWN IN TABLE D, ARE APPROXIMATE AND MAY NEED ADJUSTING AS DIRECTED BY THE ENGINEER.
- 3A. THE "WORK ZONE BEGINS" (R5-18c) SIGN SHALL BE USED ONLY IN THE INITIAL SIGNING SEQUENCE IN THE WORK ZONE. SUBSEQUENT SEQUENCES IN THE SAME WORK ZONE SHALL OMIT THIS SIGN AND THE QUANTITIES SHALL BE ADJUSTED APPROPRIATELY.
- 4A. THE MAXIMUM RECOMMENDED DISTANCE(S) BETWEEN CHANNELIZING DEVICES IN THE TAPER AREA(S) SHOULD BE 15 FEET AND SHOULD BE EQUAL IN FEET TO TWICE THE POSTED SPEED IN MILES PER HOUR IN THE PARALLEL AREA(S).
5. FOR OVERNIGHT CLOSURES, TYPE III BARRICADES SHALL BE LIGHTED.
6. WHEN CALLED FOR IN THE FHWA ACCEPTANCE LETTER FOR THE SIGN SYSTEM SELECTED, THE TYPE A WARNING FLASHER, SHOWN ON THE WARNING SIGNS, SHALL BE POSITIONED ON THE SIDE OF THE SIGN NEAREST THE ROADWAY.
7. ALL TEMPORARY SIGNS, TYPE III BARRICADES, THEIR SUPPORT SYSTEMS AND LIGHTING REQUIREMENTS SHALL MEET NCHRP 350 CRASHWORTHLY REQUIREMENTS STIPULATED IN THE CURRENT EDITION OF THE MICHIGAN MANUAL ON UNIFORM TRAFFIC CONTROL DEVICES, THE CURRENT EDITION OF THE STANDARD SPECIFICATIONS FOR CONSTRUCTION, THE STANDARD PLANS AND APPLICABLE SPECIAL PROVISIONS. ONLY DESIGNS AND MATERIALS APPROVED BY MDOT WILL BE ALLOWED.
9. ALL TRAFFIC REGULATORS SHALL BE PROPERLY TRAINED AND SUPERVISED.
- 9A. IN ANY OPERATION INVOLVING MORE THAN ONE TRAFFIC REGULATOR, ONE PERSON SHOULD BE DESIGNATED AS HEAD TRAFFIC REGULATOR.
10. ALL TRAFFIC REGULATORS' CONDUCT, THEIR EQUIPMENT, AND TRAFFIC REGULATING PROCEDURES SHALL CONFORM TO THE CURRENT EDITION OF THE MICHIGAN MANUAL OF UNIFORM TRAFFIC CONTROL DEVICES (MMUTCD) AND THE CURRENT EDITION OF THE MDOT HANDBOOK ENTITLED "TRAFFIC REGULATORS INSTRUCTION MANUAL."
11. WHEN TRAFFIC REGULATING IS ALLOWED DURING THE HOURS OF DARKNESS, APPROPRIATE LIGHTING SHALL BE PROVIDED TO SUFFICIENTLY ILLUMINATE THE TRAFFIC REGULATOR'S STATIONS.
- 12E. THE MAXIMUM DISTANCE BETWEEN THE TRAFFIC REGULATORS SHALL BE NO MORE THAN 2 MILES IN LENGTH UNLESS RESTRICTED FURTHER IN THE SPECIAL PROVISIONS FOR MAINTAINING TRAFFIC. ALL SEQUENCES OF MORE THAN 2 MILES IN LENGTH WILL REQUIRE WRITTEN PERMISSION FROM THE ENGINEER BEFORE PROCEEDING.
13. WHEN INTERSECTING ROADS OR SIGNIFICANT TRAFFIC GENERATORS (SHOPPING CENTERS, MOBILE HOME PARKS, ETC.) OCCUR WITHIN THE ONE-LANE TWO-WAY OPERATION, INTERMEDIATE TRAFFIC REGULATORS AND APPROPRIATE SIGNING SHALL BE PLACED AT THESE LOCATIONS.
14. ADDITIONAL SIGNING AND/OR ELONGATED SIGNING SEQUENCES SHOULD BE USED WHEN TRAFFIC VOLUMES ARE SIGNIFICANT ENOUGH TO CREATE BACKUPS BEYOND THE W3-4 SIGNS.
15. THE HAND HELD (PADDLE) SIGNS REQUIRED BY THE MMUTCD TO CONTROL TRAFFIC WILL BE PAID FOR AS PART OF FLAG CONTROL.
- 28E. THE TRAFFIC REGULATORS SHOULD BE POSITIONED AT OR NEAR THE SIDE OF THE ROAD SO THAT THEY ARE SEEN CLEARLY AT A MINIMUM DISTANCE OF 500 FEET. THIS MAY REQUIRE EXTENDING THE BEGINNING OF THE LANE CLOSURE TO OVERCOME VIEWING PROBLEMS CAUSED BY HILLS AND CURVES.

SIGN SIZES

DIAMOND WARNING - 48" x 48"
 R2-1 REGULATORY - 48" x 60"
 R5-18c REGULATORY - 48" x 48"

NOT TO SCALE

| | | | |
|--|--|--------------|--------|
|  TRAFFIC AND SAFETY MAINTAINING TRAFFIC TYPICAL | TYPICAL TEMPORARY TRAFFIC CONTROL FOR A TWO-LANE TWO-WAY ROADWAY WHERE ONE LANE IS CLOSED UTILIZING TRAFFIC REGULATORS, NO SPEED REDUCTION | | |
| | DRAWN BY: CON:AE:djf | OCTOBER 2011 | M0140a |
| CHECKED BY: BMM:CRB | PLAN DATE: | 2 OF 2 | |
| FILE: PW_RD/TS/Typicals/Signs/MT NON FWY/M0140a.dgn REV. 10/04/2011 | | | |

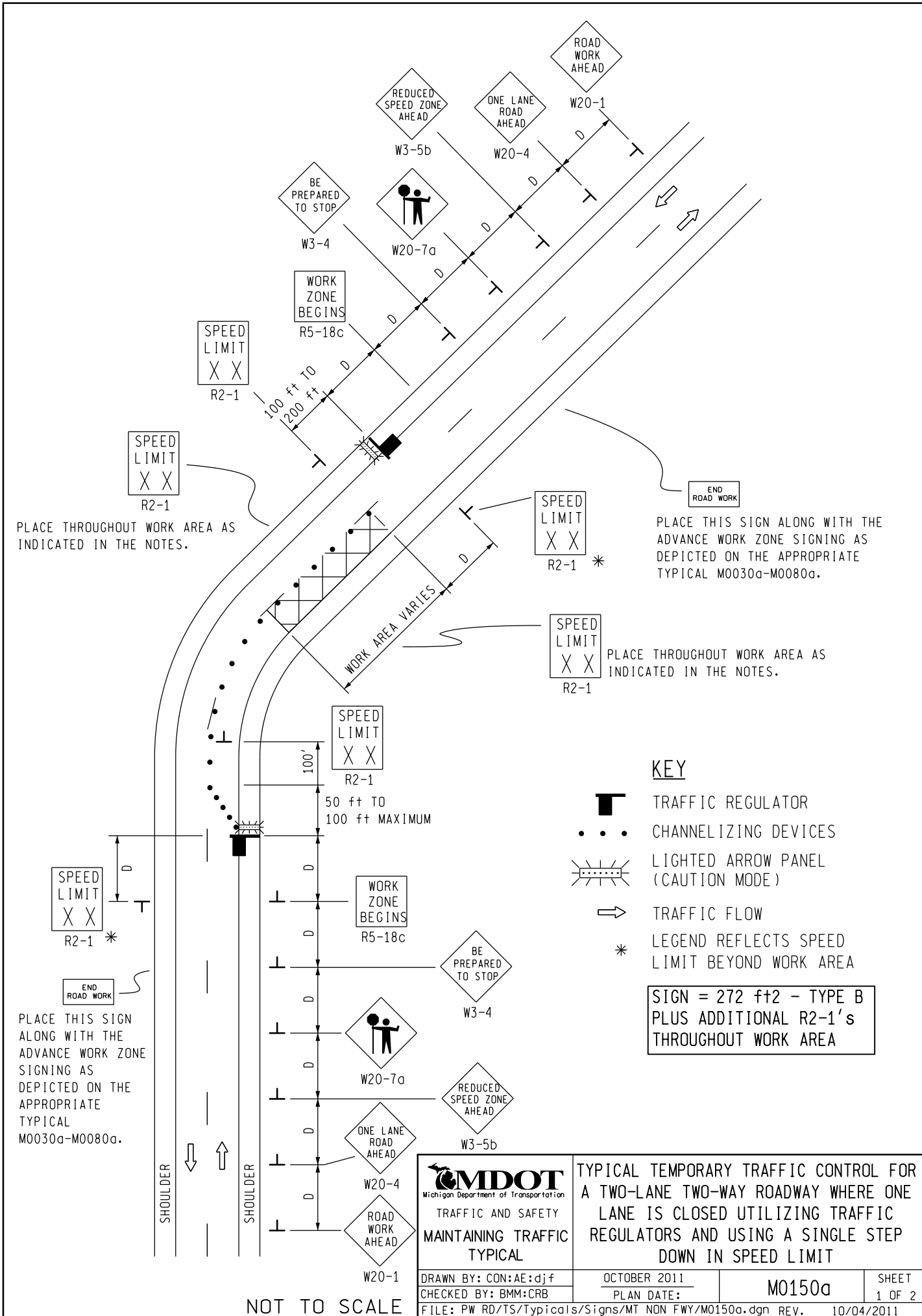





PLACE THROUGHOUT WORK AREA AS INDICATED IN THE NOTES.

PLACE THIS SIGN ALONG WITH THE ADVANCE WORK ZONE SIGNING AS DEPICTED ON THE APPROPRIATE TYPICAL M0030a-M0080a.

PLACE THROUGHOUT WORK AREA AS INDICATED IN THE NOTES.

KEY

-  TRAFFIC REGULATOR
-  CHANNELIZING DEVICES
-  LIGHTED ARROW PANEL (CAUTION MODE)
-  TRAFFIC FLOW
-  * LEGEND REFLECTS SPEED LIMIT BEYOND WORK AREA

SIGN = 272 ft±2 - TYPE B PLUS ADDITIONAL R2-1's THROUGHOUT WORK AREA

PLACE THIS SIGN ALONG WITH THE ADVANCE WORK ZONE SIGNING AS DEPICTED ON THE APPROPRIATE TYPICAL M0030a-M0080a.

MDOT
Michigan Department of Transportation
TRAFFIC AND SAFETY
MAINTAINING TRAFFIC
TYPICAL

TYPICAL TEMPORARY TRAFFIC CONTROL FOR A TWO-LANE TWO-WAY ROADWAY WHERE ONE LANE IS CLOSED UTILIZING TRAFFIC REGULATORS AND USING A SINGLE STEP DOWN IN SPEED LIMIT

| | | | |
|---|--------------|--------|--------------|
| DRAWN BY: CON:AE:djf | OCTOBER 2011 | M0150a | SHEET 1 OF 2 |
| CHECKED BY: BMM:CRB | PLAN DATE: | | |
| FILE: PW RD/TS/Typicals/Signs/MT NON FWY/M0150a.dgn REV. 10/04/2011 | | | |

NOT TO SCALE

NOTES

- 1H. D = DISTANCE BETWEEN TRAFFIC CONTROL DEVICES AND LENGTH OF LONGITUDINAL BUFFERS
SEE **M0020a** FOR "D" VALUES.
2. ALL NON-APPLICABLE SIGNING WITHIN THE CIA SHALL BE MODIFIED TO FIT CONDITIONS, COVERED OR REMOVED.
3. DISTANCES BETWEEN SIGNS, THE VALUES FOR WHICH ARE SHOWN IN TABLE D, ARE APPROXIMATE AND MAY NEED ADJUSTING AS DIRECTED BY THE ENGINEER.
- 3A. THE "WORK ZONE BEGINS" (R5-18c) SIGN SHALL BE USED ONLY IN THE INITIAL SIGNING SEQUENCE IN THE WORK ZONE. SUBSEQUENT SEQUENCES IN THE SAME WORK ZONE SHALL OMIT THIS SIGN AND THE QUANTITIES SHALL BE ADJUSTED APPROPRIATELY.
- 4A. THE MAXIMUM RECOMMENDED DISTANCE(S) BETWEEN CHANNELIZING DEVICES IN THE TAPER AREA(S) SHOULD BE 15 FEET AND SHOULD BE EQUAL IN FEET TO TWICE THE POSTED SPEED IN MILES PER HOUR IN THE PARALLEL AREA(S).
5. FOR OVERNIGHT CLOSURES, TYPE III BARRICADES SHALL BE LIGHTED.
6. WHEN CALLED FOR IN THE FHWA ACCEPTANCE LETTER FOR THE SIGN SYSTEM SELECTED, THE TYPE A WARNING FLASHER, SHOWN ON THE WARNING SIGNS, SHALL BE POSITIONED ON THE SIDE OF THE SIGN NEAREST THE ROADWAY.
7. ALL TEMPORARY SIGNS, TYPE III BARRICADES, THEIR SUPPORT SYSTEMS AND LIGHTING REQUIREMENTS SHALL MEET NCHRP 350 CRASHWORTHLY REQUIREMENTS STIPULATED IN THE CURRENT EDITION OF THE MICHIGAN MANUAL ON UNIFORM TRAFFIC CONTROL DEVICES, THE CURRENT EDITION OF THE STANDARD SPECIFICATIONS FOR CONSTRUCTION, THE STANDARD PLANS AND APPLICABLE SPECIAL PROVISIONS. ONLY DESIGNS AND MATERIALS APPROVED BY MDOT WILL BE ALLOWED.
9. ALL TRAFFIC REGULATORS SHALL BE PROPERLY TRAINED AND SUPERVISED.
- 9A. IN ANY OPERATION INVOLVING MORE THAN ONE TRAFFIC REGULATOR, ONE PERSON SHOULD BE DESIGNATED AS HEAD TRAFFIC REGULATOR.
10. ALL TRAFFIC REGULATORS' CONDUCT, THEIR EQUIPMENT, AND TRAFFIC REGULATING PROCEDURES SHALL CONFORM TO THE CURRENT EDITION OF THE MICHIGAN MANUAL OF UNIFORM TRAFFIC CONTROL DEVICES (MMUTCD) AND THE CURRENT EDITION OF THE MDOT HANDBOOK ENTITLED "TRAFFIC REGULATORS INSTRUCTION MANUAL."
11. WHEN TRAFFIC REGULATING IS ALLOWED DURING THE HOURS OF DARKNESS, APPROPRIATE LIGHTING SHALL BE PROVIDED TO SUFFICIENTLY ILLUMINATE THE TRAFFIC REGULATOR'S STATIONS.
- 12E. THE MAXIMUM DISTANCE BETWEEN THE TRAFFIC REGULATORS SHALL BE NO MORE THAN 2 MILES IN LENGTH UNLESS RESTRICTED FURTHER IN THE SPECIAL PROVISIONS FOR MAINTAINING TRAFFIC. ALL SEQUENCES OF MORE THAN 2 MILES IN LENGTH WILL REQUIRE WRITTEN PERMISSION FROM THE ENGINEER BEFORE PROCEEDING.
13. WHEN INTERSECTING ROADS OR SIGNIFICANT TRAFFIC GENERATORS (SHOPPING CENTERS, MOBILE HOME PARKS, ETC.) OCCUR WITHIN THE ONE-LANE TWO-WAY OPERATION, INTERMEDIATE TRAFFIC REGULATORS AND APPROPRIATE SIGNING SHALL BE PLACED AT THESE LOCATIONS.
14. ADDITIONAL SIGNING AND/OR ELONGATED SIGNING SEQUENCES SHOULD BE USED WHEN TRAFFIC VOLUMES ARE SIGNIFICANT ENOUGH TO CREATE BACKUPS BEYOND THE W3-4 SIGNS.
15. THE HAND HELD (PADDLE) SIGNS REQUIRED BY THE MMUTCD TO CONTROL TRAFFIC WILL BE PAID FOR AS PART OF FLAG CONTROL.
- 16A. ADDITIONAL SPEED LIMIT SIGNS REFLECTING THE REDUCED SPEED SHALL BE PLACED AFTER EACH MAJOR CROSSROAD THAT INTERSECTS THE WORK AREA WHERE THE REDUCED SPEED IS IN EFFECT, AND AT INTERVALS ALONG THE ROADWAY SUCH THAT NO SPEED LIMIT SIGNS REFLECTING THE REDUCED SPEED ARE MORE THAN TWO MILES APART.
- 16B. WHEN REDUCED SPEED LIMITS ARE UTILIZED IN THE WORK AREA, ADDITIONAL SPEED LIMIT SIGNS RETURNING TRAFFIC TO ITS NORMAL SPEED SHALL BE PLACED BEYOND THE LIMITS OF THE REDUCED SPEED AS INDICATED.
- 16E. WHEN EXISTING SPEED LIMITS ARE REDUCED MORE THAN 10 MPH, THE SPEED LIMIT SHALL BE STEPPED DOWN IN NO MORE THAN 10 MPH INCREMENTS.
- 28E. THE TRAFFIC REGULATORS SHOULD BE POSITIONED AT OR NEAR THE SIDE OF THE ROAD SO THAT THEY ARE SEEN CLEARLY AT A MINIMUM DISTANCE OF 500 FEET. THIS MAY REQUIRE EXTENDING THE BEGINNING OF THE LANE CLOSURE TO OVERCOME VIEWING PROBLEMS CAUSED BY HILLS AND CURVES.

SIGN SIZES

| | |
|------------------------|-------------|
| DIAMOND WARNING | - 48" x 48" |
| RECTANGULAR REGULATORY | - 48" x 60" |
| R5-18c REGULATORY | - 48" x 48" |

NOT TO SCALE

| | | | |
|--|--|--------------|--------|
|  MDOT Michigan Department of Transportation TRAFFIC AND SAFETY MAINTAINING TRAFFIC TYPICAL | TYPICAL TEMPORARY TRAFFIC CONTROL FOR A TWO-LANE TWO-WAY ROADWAY WHERE ONE LANE IS CLOSED UTILIZING TRAFFIC REGULATORS AND USING A SINGLE STEP DOWN IN SPEED LIMIT | | |
| | DRAWN BY: CON:AE:djf | OCTOBER 2011 | M0150a |
| CHECKED BY: BMM:CRB | PLAN DATE: | 2 OF 2 | |
| FILE: PW RD/TS/Typicals/Signs/MT NON FWY/M0150a.dgn REV. 10/04/2011 | | | |

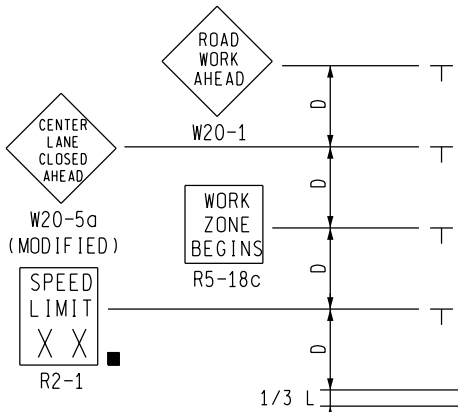

NO SPEED REDUCTION THIS DIRECTION

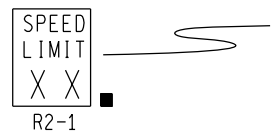

PLACE THROUGHOUT WORK AREA AS INDICATED AND AFTER ALL MAJOR CROSSROADS IF PERMANENT SIGNS ARE NOT IN PLACE.

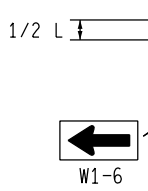

PLACE THIS SIGN ALONG WITH THE ADVANCE WORK ZONE SIGNING AS DEPICTED ON THE APPROPRIATE TYPICAL M0030a-M0050a.

PLACE THIS SIGN ALONG WITH THE ADVANCE WORK ZONE SIGNING AS DEPICTED ON THE APPROPRIATE TYPICAL M0030a-M0050a.

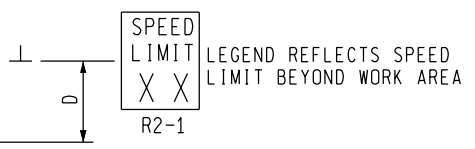

LEGEND REFLECTS SPEED LIMIT BEYOND WORK AREA

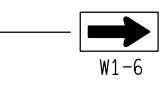

1/2 L
1/2 D

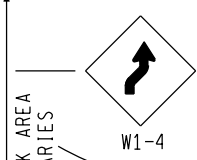

PLACE THROUGHOUT WORK AREA AS INDICATED IN THE NOTES.

1/2 L
1/3 L

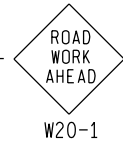
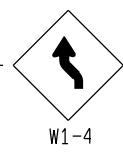
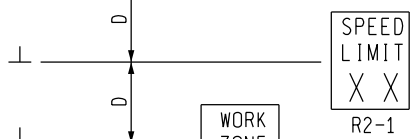

KEY

- • • CHANNELIZING DEVICES
- ⚡ LIGHTED ARROW PANEL (CAUTION MODE)
- ➡ TRAFFIC FLOW
- REFLECTS EXISTING SPEED LIMIT

SIGN = 200 ft ± 2 - TYPE B PLUS ADDITIONAL R2-1's THROUGHOUT WORK AREA

↑ MAXIMUM 10MPH SPEED REDUCTION THIS DIRECTION

| | | | |
|---|--|---|--------------------------------|
| | | <p>TYPICAL TEMPORARY TRAFFIC CONTROL FOR CLOSING ONE LANE OF A THREE LANE ROADWAY WITH CLFLTO AND SHIFTING ONE THROUGH LANE INTO THE CLFLTO USING A SINGLE STEP DOWN IN SPEED LIMIT IN ONE DIRECTION ONLY</p> | |
| <p>TRAFFIC AND SAFETY MAINTAINING TRAFFIC TYPICAL</p> | | <p>OCTOBER 2011 PLAN DATE:</p> | <p>M0232a SHEET 1 OF 2</p> |
| <p>DRAWN BY: CON:AE:DJF CHECKED BY: BMM:CRB</p> | <p>FILE: PW: RD/T&S/Typicals/Signs/MT/MT NonFwy/M0232a REV. 10/18/2011</p> | | |

NOT TO SCALE

NOTES

- 1F. D = DISTANCE BETWEEN TRAFFIC CONTROL DEVICES
 $1/2 L$, AND $1/3 L$ = MINIMUM LENGTH OF TAPER
 B = LENGTH OF LONGITUDINAL BUFFER
 SEE M0020a FOR "D," "L," AND "B" VALUES
2. ALL NON-APPLICABLE SIGNING WITHIN THE CIA SHALL BE MODIFIED TO FIT CONDITIONS, COVERED OR REMOVED.
3. DISTANCES BETWEEN SIGNS, THE VALUES FOR WHICH ARE SHOWN IN TABLE D, ARE APPROXIMATE AND MAY NEED ADJUSTING AS DIRECTED BY THE ENGINEER.
- 3A. THE "WORK ZONE BEGINS" (R5-18c) SIGN SHALL BE USED ONLY IN THE INITIAL SIGNING SEQUENCE IN THE WORK ZONE. SUBSEQUENT SEQUENCES IN THE SAME WORK ZONE SHALL OMIT THIS SIGN AND THE QUANTITIES SHALL BE ADJUSTED APPROPRIATELY.
- 4E. THE MAXIMUM RECOMMENDED DISTANCE(S) BETWEEN CHANNELIZING DEVICES SHOULD BE EQUAL IN FEET TO THE POSTED SPEED IN MILES PER HOUR ON TAPER(S) AND TWICE THE POSTED SPEED IN THE PARALLEL AREA(S).
5. FOR OVERNIGHT CLOSURES, TYPE III BARRICADES SHALL BE LIGHTED.
6. THE TYPE A WARNING FLASHER SHOWN ON THE WARNING SIGNS SHALL BE POSITIONED ON THE SIDE OF THE SIGN NEAREST THE ROADWAY.
7. ALL TEMPORARY SIGNS, TYPE III BARRICADES, THEIR SUPPORT SYSTEMS AND LIGHTING REQUIREMENTS SHALL MEET NCHRP 350 CRASHWORTHLY REQUIREMENTS STIPULATED IN THE CURRENT EDITION OF THE MICHIGAN MANUAL ON UNIFORM TRAFFIC CONTROL DEVICES, THE CURRENT EDITION OF THE STANDARD SPECIFICATIONS FOR CONSTRUCTION, THE STANDARD PLANS AND APPLICABLE SPECIAL PROVISIONS. ONLY DESIGNS AND MATERIALS APPROVED BY MDOT WILL BE ALLOWED.
8. WHEN BUFFER AREAS ARE ESTABLISHED, THERE SHALL BE NO EQUIPMENT OR MATERIALS STORED OR WORK CONDUCTED IN THE BUFFER AREA.
- 16A. ADDITIONAL SPEED LIMIT SIGNS REFLECTING THE REDUCED SPEED SHALL BE PLACED AFTER EACH MAJOR CROSSROAD THAT INTERSECTS THE WORK AREA WHERE THE REDUCED SPEED IS IN EFFECT, AND AT INTERVALS ALONG THE ROADWAY SUCH THAT NO SPEED LIMIT SIGNS REFLECTING THE REDUCED SPEED ARE MORE THAN TWO MILES APART.
- 16B. WHEN REDUCED SPEED LIMITS ARE UTILIZED IN THE WORK AREA, ADDITIONAL SPEED LIMIT SIGNS RETURNING TRAFFIC TO ITS NORMAL SPEED SHALL BE PLACED BEYOND THE LIMITS OF THE REDUCED SPEED AS INDICATED.
- 16E. WHEN EXISTING SPEED LIMITS ARE REDUCED MORE THAN 10 MPH, THE SPEED LIMIT SHALL BE STEPPED DOWN IN NO MORE THAN 10 MPH INCREMENTS.
21. ALL EXISTING PAVEMENT MARKINGS WHICH ARE IN CONFLICT WITH EITHER PROPOSED CHANGES IN TRAFFIC PATTERNS OR PROPOSED TEMPORARY TRAFFIC MARKINGS, SHALL BE REMOVED BEFORE ANY CHANGE IS MADE IN THE TRAFFIC PATTERN. EXCEPTION WILL BE MADE FOR DAYTIME-ONLY TRAFFIC PATTERNS THAT ARE ADEQUATELY DELINEATED BY OTHER TRAFFIC CONTROL DEVICES.

SIGN SIZES

| | |
|------------------------|-------------|
| DIAMOND WARNING | - 48" x 48" |
| W1-6 WARNING | - 48" x 24" |
| RECTANGULAR REGULATORY | - 48" x 60" |
| R5-18c REGULATORY | - 48" x 48" |

NOT TO SCALE

| | | | |
|---|--------------|--|--------|
|  TRAFFIC AND SAFETY MAINTAINING TRAFFIC TYPICAL | | TYPICAL TEMPORARY TRAFFIC CONTROL FOR CLOSING ONE LANE OF A THREE LANE ROADWAY WITH CLFLTO AND SHIFTING ONE THROUGH LANE INTO THE CLFLTO USING A SINGLE STEP DOWN IN SPEED LIMIT IN ONE DIRECTION ONLY | |
| DRAWN BY: CON:AE:DJF | OCTOBER 2011 | M0232a | SHEET |
| CHECKED BY: BMM:CRB | PLAN DATE: | | 2 OF 2 |
| FILE: PW: RD/T&S/Typicals/Signs/MT/MT NonFwy/M0232a REV. 10/18/2011 | | | |

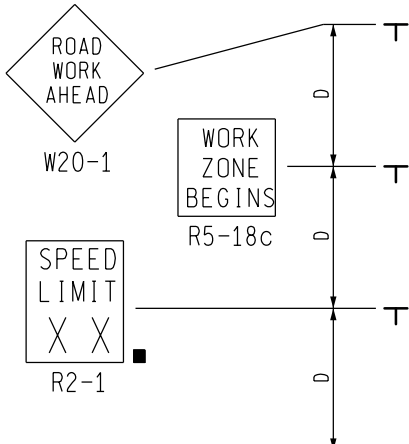

NO SPEED REDUCTION THIS DIRECTION

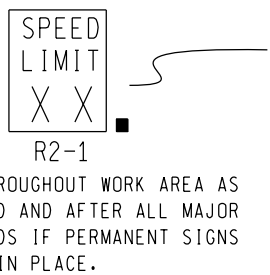

PLACE THROUGHOUT WORK AREA AS INDICATED AND AFTER ALL MAJOR CROSSROADS IF PERMANENT SIGNS ARE NOT IN PLACE.

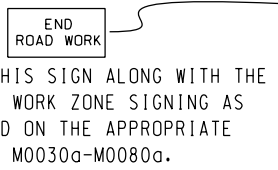

PLACE THIS SIGN ALONG WITH THE ADVANCE WORK ZONE SIGNING AS DEPICTED ON THE APPROPRIATE TYPICAL M0030a-M0080a.

KEY

- • • CHANNELIZING DEVICES
- ← LIGHTED ARROW PANEL
- TRAFFIC FLOW
- REFLECTS EXISTING SPEED LIMIT

SIGN = 172 f+2 - TYPE B PLUS ADDITIONAL R2-1's THROUGHOUT WORK AREA

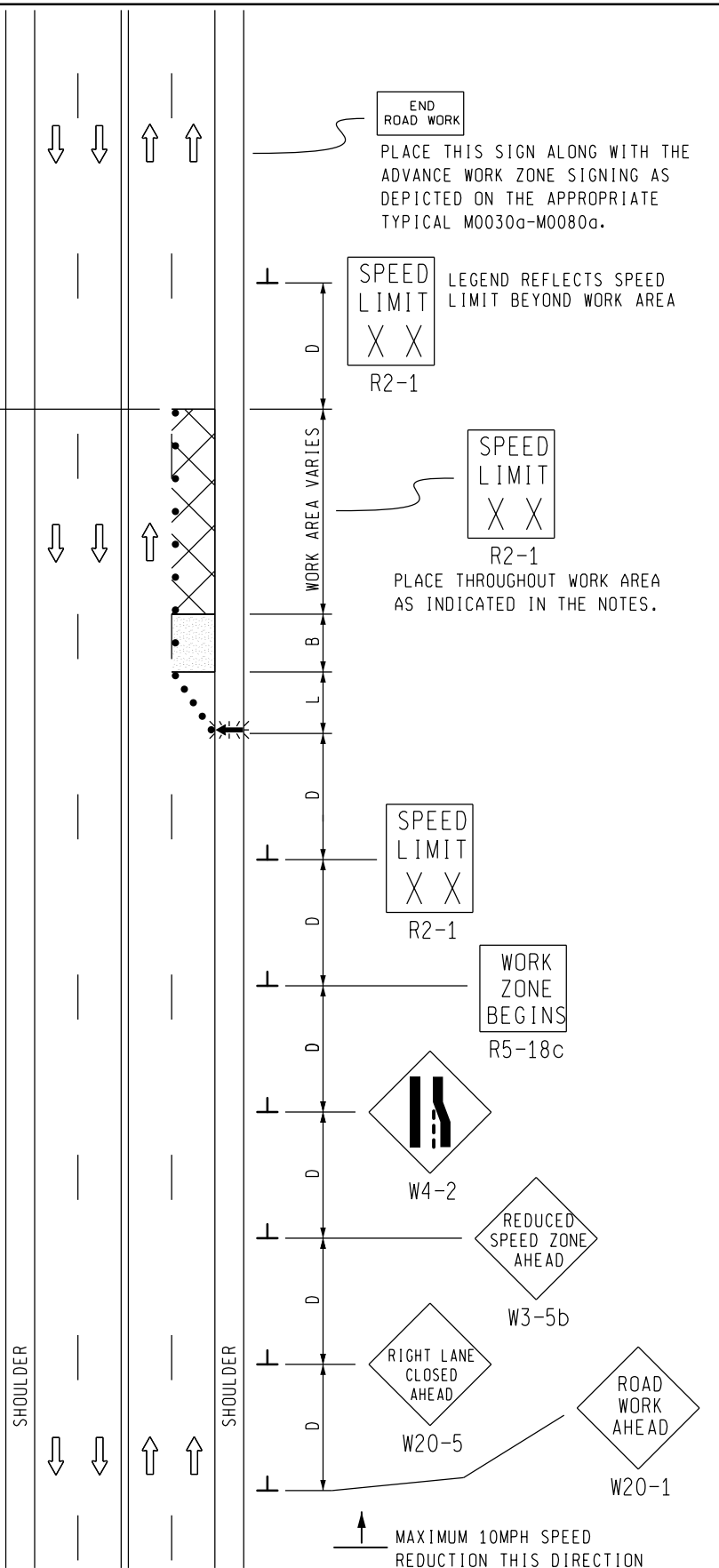

MDOT
Michigan Department of Transportation
TRAFFIC AND SAFETY
MAINTAINING TRAFFIC
TYPICAL

TYPICAL TEMPORARY TRAFFIC CONTROL FOR A ONE-LANE CLOSURE ON AN UNDIVIDED MULTI-LANE ROADWAY USING A SINGLE STEP DOWN IN SPEED LIMIT IN ONE DIRECTION ONLY

| | | | |
|---|--------------|--------|--------------|
| DRAWN BY: CON:AE:djf | OCTOBER 2011 | M0250a | SHEET 1 OF 2 |
| CHECKED BY: BMM:CRB | PLAN DATE: | | |
| FILE: PW RD/TS/Typicals/Signs/MT NON FWY/M0250a.dgn REV. 10/11/2011 | | | |

NOT TO SCALE

NOTES

- 1B. D = DISTANCE BETWEEN TRAFFIC CONTROL DEVICES
 L = MINIMUM LENGTH OF TAPER
 B = LENGTH OF LONGITUDINAL BUFFER
 SEE **M0020a** FOR "D," "L," AND "B" VALUES
2. ALL NON-APPLICABLE SIGNING WITHIN THE CIA SHALL BE MODIFIED TO FIT CONDITIONS, COVERED OR REMOVED.
3. DISTANCES BETWEEN SIGNS, THE VALUES FOR WHICH ARE SHOWN IN TABLE D, ARE APPROXIMATE AND MAY NEED ADJUSTING AS DIRECTED BY THE ENGINEER.
- 3A. THE "WORK ZONE BEGINS" (R5-18c) SIGN SHALL BE USED ONLY IN THE INITIAL SIGNING SEQUENCE IN THE WORK ZONE. SUBSEQUENT SEQUENCES IN THE SAME WORK ZONE SHALL OMIT THIS SIGN AND THE QUANTITIES SHALL BE ADJUSTED APPROPRIATELY.
- 4E. THE MAXIMUM RECOMMENDED DISTANCE(S) BETWEEN CHANNELIZING DEVICES SHOULD BE EQUAL IN FEET TO THE POSTED SPEED IN MILES PER HOUR ON TAPER(S) AND TWICE THE POSTED SPEED IN THE PARALLEL AREA(S).
5. FOR OVERNIGHT CLOSURES, TYPE III BARRICADES SHALL BE LIGHTED.
6. WHEN CALLED FOR IN THE FHWA ACCEPTANCE LETTER FOR THE SIGN SYSTEM SELECTED, THE TYPE A WARNING FLASHER, SHOWN ON THE WARNING SIGNS, SHALL BE POSITIONED ON THE SIDE OF THE SIGN NEAREST THE ROADWAY.
7. ALL TEMPORARY SIGNS, TYPE III BARRICADES, THEIR SUPPORT SYSTEMS AND LIGHTING REQUIREMENTS SHALL MEET NCHRP 350 CRASHWORTHY REQUIREMENTS STIPULATED IN THE CURRENT EDITION OF THE MICHIGAN MANUAL ON UNIFORM TRAFFIC CONTROL DEVICES, THE CURRENT EDITION OF THE STANDARD SPECIFICATIONS FOR CONSTRUCTION, THE STANDARD PLANS AND APPLICABLE SPECIAL PROVISIONS. ONLY DESIGNS AND MATERIALS APPROVED BY MDOT WILL BE ALLOWED.
8. WHEN BUFFER AREAS ARE ESTABLISHED, THERE SHALL BE NO EQUIPMENT OR MATERIALS STORED OR WORK CONDUCTED IN THE BUFFER AREA.
- 16A. ADDITIONAL SPEED LIMIT SIGNS REFLECTING THE REDUCED SPEED SHALL BE PLACED AFTER EACH MAJOR CROSSROAD THAT INTERSECTS THE WORK AREA WHERE THE REDUCED SPEED IS IN EFFECT, AND AT INTERVALS ALONG THE ROADWAY SUCH THAT NO SPEED LIMIT SIGNS REFLECTING THE REDUCED SPEED ARE MORE THAN TWO MILES APART.
- 16B. WHEN REDUCED SPEED LIMITS ARE UTILIZED IN THE WORK AREA, ADDITIONAL SPEED LIMIT SIGNS RETURNING TRAFFIC TO ITS NORMAL SPEED SHALL BE PLACED BEYOND THE LIMITS OF THE REDUCED SPEED AS INDICATED.
- 16E. WHEN EXISTING SPEED LIMITS ARE REDUCED MORE THAN 10 MPH, THE SPEED LIMIT SHALL BE STEPPED DOWN IN NO MORE THAN 10 MPH INCREMENTS.
21. ALL EXISTING PAVEMENT MARKINGS WHICH ARE IN CONFLICT WITH EITHER PROPOSED CHANGES IN TRAFFIC PATTERNS OR PROPOSED TEMPORARY TRAFFIC MARKINGS, SHALL BE REMOVED BEFORE ANY CHANGE IS MADE IN THE TRAFFIC PATTERN. EXCEPTION WILL BE MADE FOR DAYTIME-ONLY TRAFFIC PATTERNS THAT ARE ADEQUATELY DELINEATED BY OTHER TRAFFIC CONTROL DEVICES.
26. THE LIGHTED ARROW PANEL SHALL BE LOCATED AT THE BEGINNING OF THE TAPER AS SHOWN. WHEN PHYSICAL LIMITATIONS RESTRICT ITS PLACEMENT AS INDICATED, THEN IT SHALL BE PLACED AS CLOSE TO THE BEGINNING OF THE TAPER AS POSSIBLE.

SIGN SIZES

DIAMOND WARNING - 48" x 48"
 RECTANGULAR REGULATORY - 48" x 60"
 R5-18c REGULATORY - 48" x 48"

NOT TO SCALE

| | | | |
|--|--|---------------|--------|
|  TRAFFIC AND SAFETY MAINTAINING TRAFFIC TYPICAL | TYPICAL TEMPORARY TRAFFIC CONTROL FOR A ONE-LANE CLOSURE ON AN UNDIVIDED MULTI-LANE ROADWAY USING A SINGLE STEP DOWN IN SPEED LIMIT IN ONE DIRECTION ONLY | | |
| DRAWN BY: CON:AE:djf | OCTOBER 2011 | M0250a | SHEET |
| CHECKED BY: BMM:CRB | PLAN DATE: | | 2 OF 2 |
| FILE: PW RD/TS/Typicals/Signs/MT NON FWY/M0250a.dgn REV. 10/11/2011 | | | |

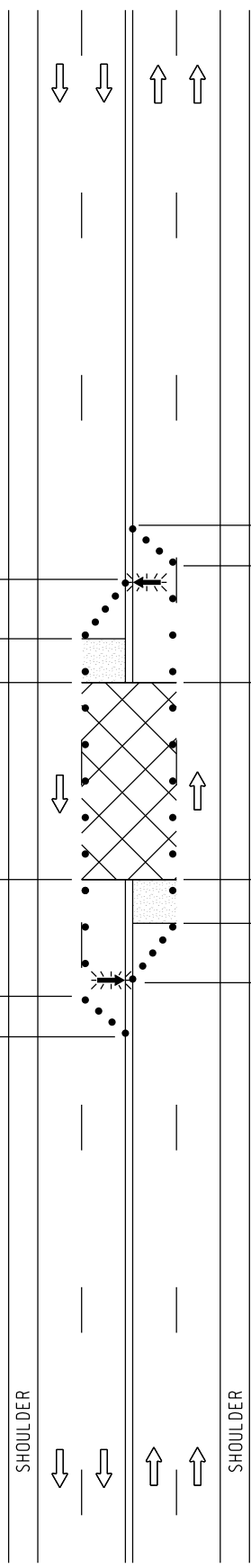
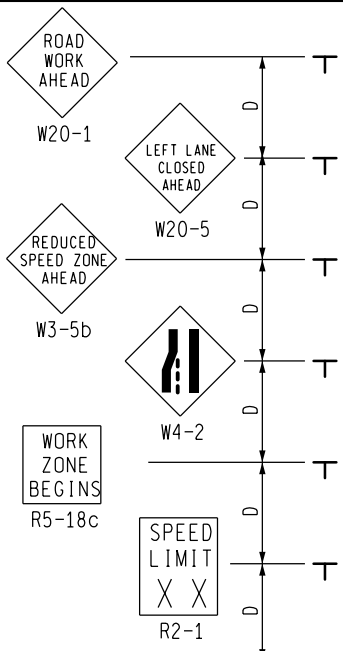

PLACE THIS SIGN ALONG WITH THE ADVANCE WORK ZONE SIGNING AS DEPICTED ON THE APPROPRIATE TYPICAL M0030a-M0080a.

END ROAD WORK

SPEED LIMIT XX R2-1

PLACE THROUGHOUT WORK AREA AS INDICATED IN THE NOTES.

100 ft MINIMUM

SPEED LIMIT XX R2-1

PLACE THROUGHOUT WORK AREA AS INDICATED IN THE NOTES.

SPEED LIMIT XX R2-1

PLACE THROUGHOUT WORK AREA AS INDICATED IN THE NOTES.

LEGEND REFLECTS SPEED LIMIT BEYOND WORK AREA

SPEED LIMIT XX R2-1

END ROAD WORK

PLACE THIS SIGN ALONG WITH THE ADVANCE WORK ZONE SIGNING AS DEPICTED ON THE APPROPRIATE TYPICAL M0030a-M0080a.

KEY

- • • CHANNELIZING DEVICES
- ← LIGHTED ARROW PANEL
- ⇒ TRAFFIC FLOW

SIGN = 240 ft± - TYPE B PLUS ADDITIONAL R2-1's THROUGHOUT WORK AREA

MDOT
Michigan Department of Transportation
TRAFFIC AND SAFETY
MAINTAINING TRAFFIC
TYPICAL

TYPICAL TEMPORARY TRAFFIC CONTROL FOR CLOSING THE CENTER TWO LANES OF A MULTI-LANE UNDIVIDED ROADWAY, (NO CLFLT0) USING A SINGLE STEP DOWN IN SPEED LIMIT

| | | | |
|---|--------------|--------|--------------|
| DRAWN BY: CON:AE:djf | OCTOBER 2011 | M0280a | SHEET 1 OF 2 |
| CHECKED BY: BMM:CRB | PLAN DATE: | | |
| FILE: PW RD/TS/Typicals/Signs/MT NON FWY/M0280a.dgn REV. 10/12/2011 | | | |

NOT TO SCALE

NOTES

- 1B. D = DISTANCE BETWEEN TRAFFIC CONTROL DEVICES
L = MINIMUM LENGTH OF TAPER
B = LENGTH OF LONGITUDINAL BUFFER
SEE M0020a FOR "D," "L," AND "B" VALUES
2. ALL NON-APPLICABLE SIGNING WITHIN THE CIA SHALL BE MODIFIED TO FIT CONDITIONS, COVERED OR REMOVED.
3. DISTANCES BETWEEN SIGNS, THE VALUES FOR WHICH ARE SHOWN IN TABLE D, ARE APPROXIMATE AND MAY NEED ADJUSTING AS DIRECTED BY THE ENGINEER.
- 3A. THE "WORK ZONE BEGINS" (R5-18c) SIGN SHALL BE USED ONLY IN THE INITIAL SIGNING SEQUENCE IN THE WORK ZONE. SUBSEQUENT SEQUENCES IN THE SAME WORK ZONE SHALL OMIT THIS SIGN AND THE QUANTITIES SHALL BE ADJUSTED APPROPRIATELY.
- 4B. THE MAXIMUM RECOMMENDED DISTANCE(S) BETWEEN CHANNELIZING DEVICES SHOULD BE EQUAL IN FEET TO THE POSTED SPEED IN MILES PER HOUR ON MERGING TAPER(S), TWICE THE POSTED SPEED IN THE PARALLEL AREA(S), AND 25 FEET IN THE DOWNSTREAM TAPER AREA(S).
5. FOR OVERNIGHT CLOSURES, TYPE III BARRICADES SHALL BE LIGHTED.
6. WHEN CALLED FOR IN THE FHWA ACCEPTANCE LETTER FOR THE SIGN SYSTEM SELECTED, THE TYPE A WARNING FLASHER, SHOWN ON THE WARNING SIGNS, SHALL BE POSITIONED ON THE SIDE OF THE SIGN NEAREST THE ROADWAY.
7. ALL TEMPORARY SIGNS, TYPE III BARRICADES, THEIR SUPPORT SYSTEMS AND LIGHTING REQUIREMENTS SHALL MEET NCHRP 350 CRASHWORTHLY REQUIREMENTS STIPULATED IN THE CURRENT EDITION OF THE MICHIGAN MANUAL ON UNIFORM TRAFFIC CONTROL DEVICES, THE CURRENT EDITION OF THE STANDARD SPECIFICATIONS FOR CONSTRUCTION, THE STANDARD PLANS AND APPLICABLE SPECIAL PROVISIONS. ONLY DESIGNS AND MATERIALS APPROVED BY MDOT WILL BE ALLOWED.
8. WHEN BUFFER AREAS ARE ESTABLISHED, THERE SHALL BE NO EQUIPMENT OR MATERIALS STORED OR WORK CONDUCTED IN THE BUFFER AREA.
- 16A. ADDITIONAL SPEED LIMIT SIGNS REFLECTING THE REDUCED SPEED SHALL BE PLACED AFTER EACH MAJOR CROSSROAD THAT INTERSECTS THE WORK AREA WHERE THE REDUCED SPEED IS IN EFFECT, AND AT INTERVALS ALONG THE ROADWAY SUCH THAT NO SPEED LIMIT SIGNS REFLECTING THE REDUCED SPEED ARE MORE THAN TWO MILES APART.
- 16B. WHEN REDUCED SPEED LIMITS ARE UTILIZED IN THE WORK AREA, ADDITIONAL SPEED LIMIT SIGNS RETURNING TRAFFIC TO ITS NORMAL SPEED SHALL BE PLACED BEYOND THE LIMITS OF THE REDUCED SPEED AS INDICATED.
- 16E. WHEN EXISTING SPEED LIMITS ARE REDUCED MORE THAN 10 MPH, THE SPEED LIMIT SHALL BE STEPPED DOWN IN NO MORE THAN 10 MPH INCREMENTS.
21. ALL EXISTING PAVEMENT MARKINGS WHICH ARE IN CONFLICT WITH EITHER PROPOSED CHANGES IN TRAFFIC PATTERNS OR PROPOSED TEMPORARY TRAFFIC MARKINGS, SHALL BE REMOVED BEFORE ANY CHANGE IS MADE IN THE TRAFFIC PATTERN. EXCEPTION WILL BE MADE FOR DAYTIME-ONLY TRAFFIC PATTERNS THAT ARE ADEQUATELY DELINEATED BY OTHER TRAFFIC CONTROL DEVICES.
- 26C. THE LIGHTED ARROW PANEL SHALL BE LOCATED AT THE BEGINNING OF THE MERGING TAPER AS SHOWN. WHEN PHYSICAL LIMITATIONS RESTRICT ITS PLACEMENT AS INDICATED, THEN IT SHALL BE PLACED AS CLOSE TO THE BEGINNING OF THE MERGING TAPER AS POSSIBLE.

SIGN SIZES

| | |
|------------------------|-------------|
| DIAMOND WARNING | - 48" x 48" |
| RECTANGULAR REGULATORY | - 48" x 60" |
| R5-18c REGULATORY | - 48" x 48" |

NOT TO SCALE

| | |
|---|--|
|  TRAFFIC AND SAFETY MAINTAINING TRAFFIC TYPICAL | TYPICAL TEMPORARY TRAFFIC CONTROL FOR CLOSING THE CENTER TWO LANES OF A MULTI-LANE UNDIVIDED ROADWAY, (NO CLFLT0) USING A SINGLE STEP DOWN IN SPEED LIMIT |
| DRAWN BY: CON:AE:djf | OCTOBER 2011 |
| CHECKED BY: BMM:CRB | PLAN DATE: |
| FILE: PW RD/TS/Typicals/Signs/MT NON FWY/M0280a.dgn | REV. 10/12/2011 |
| M0280a | SHEET 2 OF 2 |

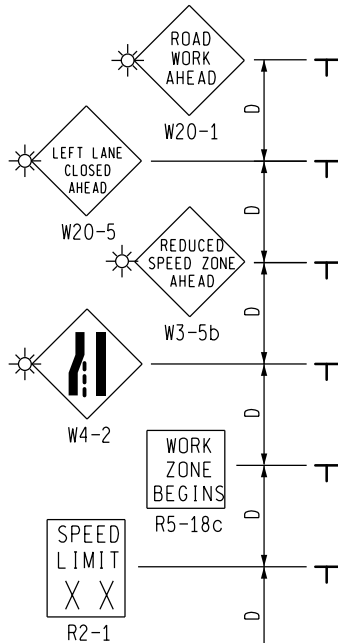

KEY

- • • CHANNELIZING DEVICES
- ← LIGHTED ARROW PANEL
- ☀ TYPE A WARNING FLASHER (REQUIRED)
- ⇒ TRAFFIC FLOW

SIGN = 304 f+2 - TYPE B PLUS ADDITIONAL R2-1's THROUGHOUT WORK AREA

PLACE THIS SIGN ALONG WITH THE ADVANCE WORK ZONE SIGNING AS DEPICTED ON THE APPROPRIATE TYPICAL M0030a-M0080a.

LEGEND REFLECTS SPEED LIMIT BEYOND WORK AREA

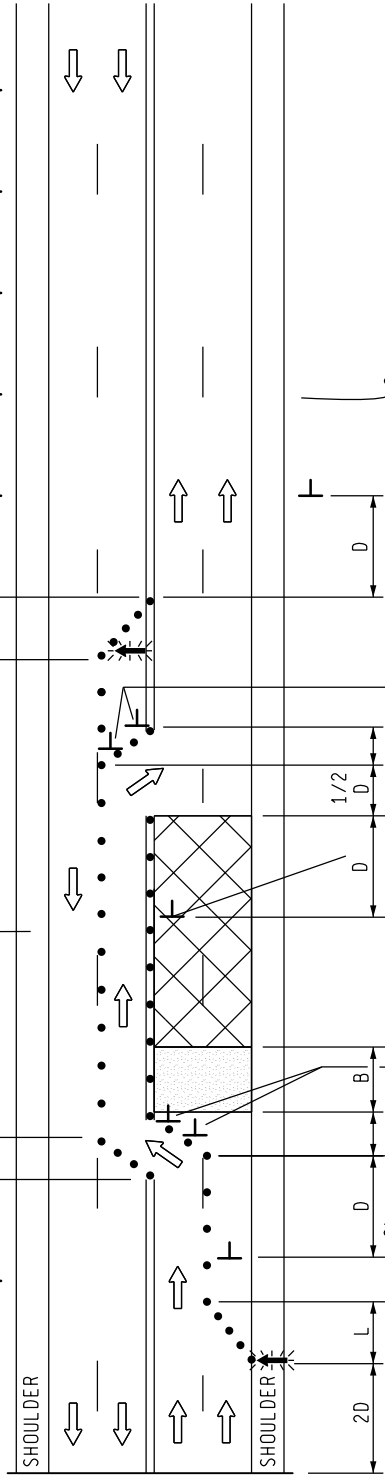

PLACE THROUGHOUT WORK AREA AS INDICATED IN THE NOTES.

PLACE THROUGHOUT WORK AREA AS INDICATED IN THE NOTES.

LEGEND REFLECTS SPEED LIMIT BEYOND WORK AREA

A MATCH A

| | | |
|--|--|------------------------------------|
| <p>TRAFFIC AND SAFETY MAINTAINING TRAFFIC TYPICAL</p> | <p>TYPICAL TEMPORARY TRAFFIC CONTROL FOR CLOSING ONE-HALF OF A FOUR-LANE UNDIVIDED ROADWAY USING A SINGLE STEP DOWN IN SPEED LIMIT</p> | |
| | <p>DRAWN BY: CON:AE:djf CHECKED BY: BMM:CRB</p> | <p>OCTOBER 2011 PLAN DATE:</p> |
| <p>FILE: K:\-DGN-TSR-STDS-ENGL\ISH-MNTTRF-M0310a.dgn REV. 10/18/2011</p> | | |

NOT TO SCALE

A MATCH A

PLACE THIS SIGN ALONG WITH THE ADVANCE WORK ZONE SIGNING AS DEPICTED ON THE APPROPRIATE TYPICAL M0030a-M0080a.

END ROAD WORK

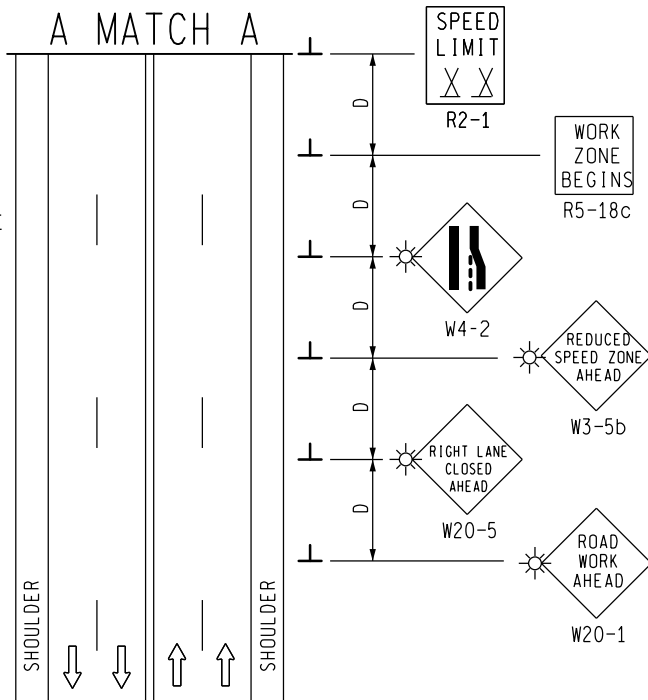

| | | |
|--|--|------------------------------------|
| <p>TRAFFIC AND SAFETY MAINTAINING TRAFFIC TYPICAL</p> | <p>TYPICAL TEMPORARY TRAFFIC CONTROL FOR CLOSING ONE-HALF OF A FOUR-LANE UNDIVIDED ROADWAY USING A SINGLE STEP DOWN IN SPEED LIMIT</p> | |
| | <p>DRAWN BY: CON:AE:djf CHECKED BY: BMM:CRB</p> | <p>OCTOBER 2011 PLAN DATE:</p> |
| <p>FILE: K:-DGN-TSR-STDS-ENGLISH-MNTTRF-M0310a.dgn REV. 10/18/2011</p> | | |

NOT TO SCALE

NOTES

- 1C. D = DISTANCE BETWEEN TRAFFIC CONTROL DEVICES
L & 1/2 L = MINIMUM LENGTH OF TAPER
B = LENGTH OF LONGITUDINAL BUFFER
SEE **M0020a** FOR "D," "L," AND "B" VALUES
2. ALL NON-APPLICABLE SIGNING WITHIN THE CIA SHALL BE MODIFIED TO FIT CONDITIONS, COVERED OR REMOVED.
3. DISTANCES BETWEEN SIGNS, THE VALUES FOR WHICH ARE SHOWN IN TABLE D, ARE APPROXIMATE AND MAY NEED ADJUSTING AS DIRECTED BY THE ENGINEER.
- 3A. THE "WORK ZONE BEGINS" (R5-18c) SIGN SHALL BE USED ONLY IN THE INITIAL SIGNING SEQUENCE IN THE WORK ZONE. SUBSEQUENT SEQUENCES IN THE SAME WORK ZONE SHALL OMIT THIS SIGN AND THE QUANTITIES SHALL BE ADJUSTED APPROPRIATELY.
- 4E. THE MAXIMUM RECOMMENDED DISTANCE(S) BETWEEN CHANNELIZING DEVICES SHOULD BE EQUAL IN FEET TO THE POSTED SPEED IN MILES PER HOUR ON TAPER(S) AND TWICE THE POSTED SPEED IN THE PARALLEL AREA(S).
5. FOR OVERNIGHT CLOSURES, TYPE III BARRICADES SHALL BE LIGHTED.
6. THE TYPE A WARNING FLASHER SHOWN ON THE WARNING SIGNS SHALL BE POSITIONED ON THE SIDE OF THE SIGN NEAREST THE ROADWAY.
7. ALL TEMPORARY SIGNS, TYPE III BARRICADES, THEIR SUPPORT SYSTEMS AND LIGHTING REQUIREMENTS SHALL MEET NCHRP 350 CRASHWORTHY REQUIREMENTS STIPULATED IN THE CURRENT EDITION OF THE MICHIGAN MANUAL ON UNIFORM TRAFFIC CONTROL DEVICES, THE CURRENT EDITION OF THE STANDARD SPECIFICATIONS FOR CONSTRUCTION, THE STANDARD PLANS AND APPLICABLE SPECIAL PROVISIONS. ONLY DESIGNS AND MATERIALS APPROVED BY MDOT WILL BE ALLOWED.
8. WHEN BUFFER AREAS ARE ESTABLISHED, THERE SHALL BE NO EQUIPMENT OR MATERIALS STORED OR WORK CONDUCTED IN THE BUFFER AREA.
- 16A. ADDITIONAL SPEED LIMIT SIGNS REFLECTING THE REDUCED SPEED SHALL BE PLACED AFTER EACH MAJOR CROSSROAD THAT INTERSECTS THE WORK AREA WHERE THE REDUCED SPEED IS IN EFFECT, AND AT INTERVALS ALONG THE ROADWAY SUCH THAT NO SPEED LIMIT SIGNS REFLECTING THE REDUCED SPEED ARE MORE THAN TWO MILES APART.
- 16B. WHEN REDUCED SPEED LIMITS ARE UTILIZED IN THE WORK AREA, ADDITIONAL SPEED LIMIT SIGNS RETURNING TRAFFIC TO ITS NORMAL SPEED SHALL BE PLACED BEYOND THE LIMITS OF THE REDUCED SPEED AS INDICATED.
- 16E. WHEN EXISTING SPEED LIMITS ARE REDUCED MORE THAN 10 MPH, THE SPEED LIMIT SHALL BE STEPPED DOWN IN NO MORE THAN 10 MPH INCREMENTS.
21. ALL EXISTING PAVEMENT MARKINGS WHICH ARE IN CONFLICT WITH EITHER PROPOSED CHANGES IN TRAFFIC PATTERNS OR PROPOSED TEMPORARY TRAFFIC MARKINGS, SHALL BE REMOVED BEFORE ANY CHANGE IS MADE IN THE TRAFFIC PATTERN. EXCEPTION WILL BE MADE FOR DAYTIME-ONLY TRAFFIC PATTERNS THAT ARE ADEQUATELY DELINEATED BY OTHER TRAFFIC CONTROL DEVICES.
26. THE LIGHTED ARROW PANEL SHALL BE LOCATED AT THE BEGINNING OF THE TAPER AS SHOWN. WHEN PHYSICAL LIMITATIONS RESTRICT ITS PLACEMENT AS INDICATED, THEN IT SHALL BE PLACED AS CLOSE TO THE BEGINNING OF THE TAPER AS POSSIBLE.

SIGN SIZES

| | |
|------------------------|-------------|
| DIAMOND WARNING | - 48" x 48" |
| W1-6 WARNING | - 48" x 24" |
| RECTANGULAR REGULATORY | - 48" x 60" |
| R5-18c REGULATORY | - 48" x 48" |

NOT TO SCALE

| | | | |
|---|--|--------------|------------|
|  TRAFFIC AND SAFETY MAINTAINING TRAFFIC TYPICAL | TYPICAL TEMPORARY TRAFFIC CONTROL FOR CLOSING ONE-HALF OF A FOUR-LANE UNDIVIDED ROADWAY USING A SINGLE STEP DOWN IN SPEED LIMIT | | |
| | DRAWN BY: CON:AE:djf | OCTOBER 2011 | M0310a |
| CHECKED BY: BMM:CRB | PLAN DATE: | 3 OF 3 | |
| FILE: K:\-DGN-TSR-STD5-ENGLISH-MNTTRF-M0310a.dgn | | REV. | 10/18/2011 |

KEY

- • • CHANNELIZING DEVICES
- ⇒ TRAFFIC FLOW
- REFLECTS EXISTING SPEED LIMIT

SIGN = 136 f+2 - TYPE B PLUS ADDITIONAL R2-1's THROUGHOUT WORK AREA

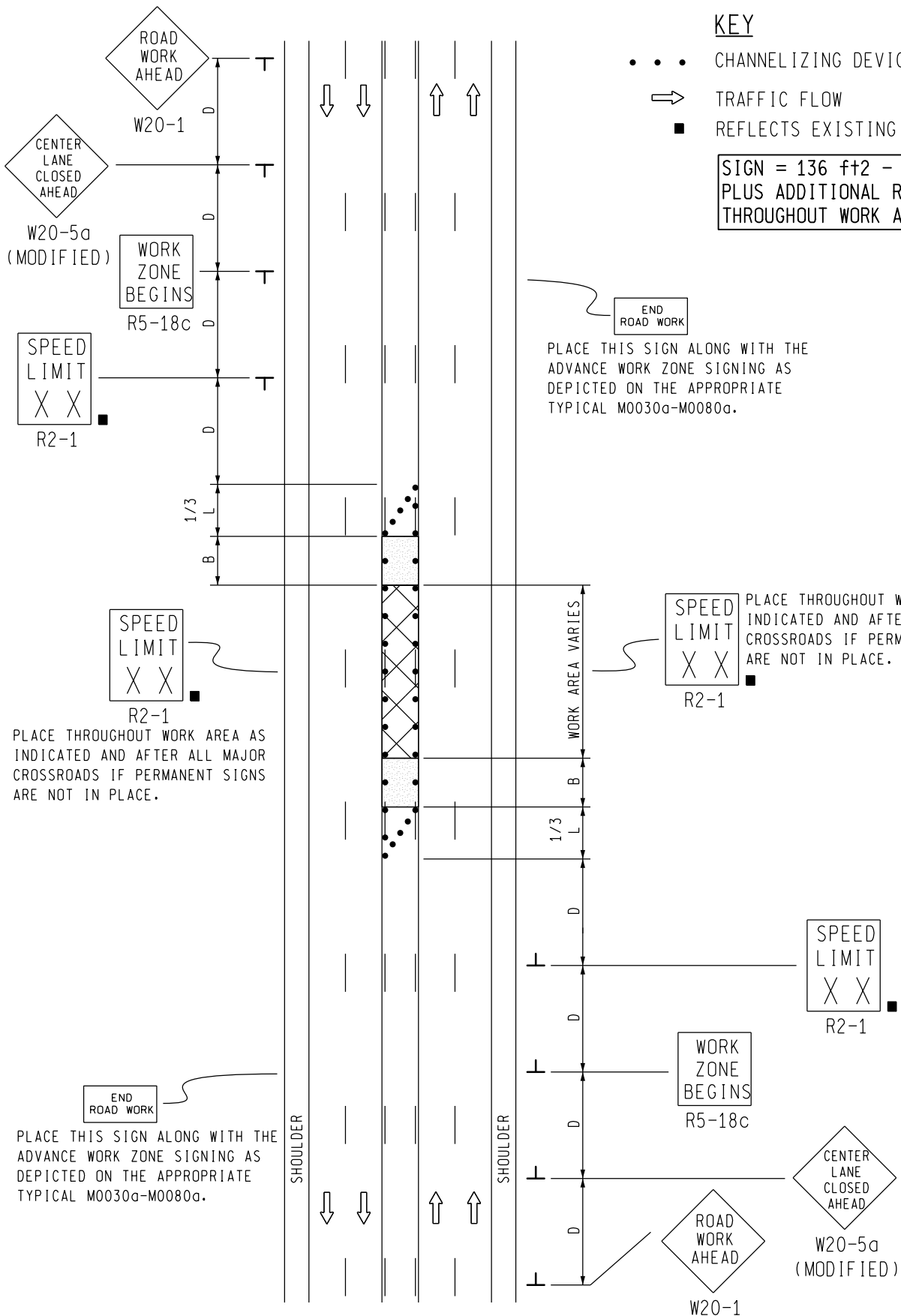

END ROAD WORK
PLACE THIS SIGN ALONG WITH THE ADVANCE WORK ZONE SIGNING AS DEPICTED ON THE APPROPRIATE TYPICAL M0030a-M0080a.

SPEED LIMIT XX R2-1
PLACE THROUGHOUT WORK AREA AS INDICATED AND AFTER ALL MAJOR CROSSROADS IF PERMANENT SIGNS ARE NOT IN PLACE.

SPEED LIMIT XX R2-1
PLACE THROUGHOUT WORK AREA AS INDICATED AND AFTER ALL MAJOR CROSSROADS IF PERMANENT SIGNS ARE NOT IN PLACE.

END ROAD WORK
PLACE THIS SIGN ALONG WITH THE ADVANCE WORK ZONE SIGNING AS DEPICTED ON THE APPROPRIATE TYPICAL M0030a-M0080a.

| | | | |
|--|------------------------------------|---|-------------------------|
| <p>TRAFFIC AND SAFETY MAINTAINING TRAFFIC TYPICAL</p> | | <p>TYPICAL TEMPORARY TRAFFIC CONTROL FOR A CENTER-LANE FOR LEFT TURN ONLY CLOSURE ON A MULTI-LANE UNDIVIDED ROADWAY, WORKERS NOT PRESENT NO SPEED REDUCTION</p> | |
| <p>DRAWN BY: CON:AE:djf CHECKED BY: BMM:CRB</p> | <p>OCTOBER 2011 PLAN DATE:</p> | <p>M0330a</p> | <p>SHEET 1 OF 2</p> |
| <p>FILE: PW RD/TS/Typicals/Signs/MT NON FWY/M0330a.dgn REV. 10/18/2011</p> | | | |

NOT TO SCALE

NOTES

1. D = DISTANCE BETWEEN TRAFFIC CONTROL DEVICES
 $1/3 L$ = MINIMUM LENGTH OF TAPER
 B = LENGTH OF LONGITUDINAL BUFFER
 SEE M0020a FOR "D," "L," AND "B" VALUES
2. ALL NON-APPLICABLE SIGNING WITHIN THE CIA SHALL BE MODIFIED TO FIT CONDITIONS, COVERED OR REMOVED.
3. DISTANCES BETWEEN SIGNS, THE VALUES FOR WHICH ARE SHOWN IN TABLE D, ARE APPROXIMATE AND MAY NEED ADJUSTING AS DIRECTED BY THE ENGINEER.
- 3A. THE "WORK ZONE BEGINS" (R5-18c) SIGN SHALL BE USED ONLY IN THE INITIAL SIGNING SEQUENCE IN THE WORK ZONE. SUBSEQUENT SEQUENCES IN THE SAME WORK ZONE SHALL OMIT THIS SIGN AND THE QUANTITIES SHALL BE ADJUSTED APPROPRIATELY.
- 4E. THE MAXIMUM RECOMMENDED DISTANCE(S) BETWEEN CHANNELIZING DEVICES SHOULD BE EQUAL IN FEET TO THE POSTED SPEED IN MILES PER HOUR ON TAPER(S) AND TWICE THE POSTED SPEED IN THE PARALLEL AREA(S).
5. FOR OVERNIGHT CLOSURES, TYPE III BARRICADES SHALL BE LIGHTED.
6. WHEN CALLED FOR IN THE FHWA ACCEPTANCE LETTER FOR THE SIGN SYSTEM SELECTED, THE TYPE A WARNING FLASHER, SHOWN ON THE WARNING SIGNS, SHALL BE POSITIONED ON THE SIDE OF THE SIGN NEAREST THE ROADWAY.
7. ALL TEMPORARY SIGNS, TYPE III BARRICADES, THEIR SUPPORT SYSTEMS AND LIGHTING REQUIREMENTS SHALL MEET NCHRP 350 CRASHWORTHLY REQUIREMENTS STIPULATED IN THE CURRENT EDITION OF THE MICHIGAN MANUAL ON UNIFORM TRAFFIC CONTROL DEVICES, THE CURRENT EDITION OF THE STANDARD SPECIFICATIONS FOR CONSTRUCTION, THE STANDARD PLANS AND APPLICABLE SPECIAL PROVISIONS. ONLY DESIGNS AND MATERIALS APPROVED BY MDOT WILL BE ALLOWED.
8. WHEN BUFFER AREAS ARE ESTABLISHED, THERE SHALL BE NO EQUIPMENT OR MATERIALS STORED OR WORK CONDUCTED IN THE BUFFER AREA.
- 25A. THIS SEQUENCE SHOULD ONLY BE USED WHEN WORKERS ARE NOT PRESENT, E.G., FOR CURING CONCRETE OVERNIGHT, ETC. WHEN WORK IS BEING CONDUCTED IN THE CENTER LANE, AN ADJACENT LANE (IN ONE OR BOTH DIRECTIONS) SHOULD ALSO BE CLOSED UTILIZING THE APPROPRIATE TYPICAL SIGNING SEQUENCE.

SIGN SIZES

DIAMOND WARNING - 48" x 48"
 R2-1 REGULATORY - 48" x 60"
 R5-18c REGULATORY - 48" x 48"

NOT TO SCALE

| | | | |
|---|--|--------|-----------------|
|  TRAFFIC AND SAFETY MAINTAINING TRAFFIC TYPICAL | TYPICAL TEMPORARY TRAFFIC CONTROL FOR A CENTER-LANE FOR LEFT TURN ONLY CLOSURE ON A MULTI-LANE UNDIVIDED ROADWAY, WORKERS NOT PRESENT NO SPEED REDUCTION | | |
| DRAWN BY: CON:AE:djf CHECKED BY: BMM:CRB | OCTOBER 2011 PLAN DATE: | M0330a | SHEET 2 OF 2 |
| FILE: PW_RD/TS/Typicals/Signs/MT NON FWY/M0330a.dgn REV. 10/18/2011 | | | |

NO SPEED REDUCTION
THIS DIRECTION

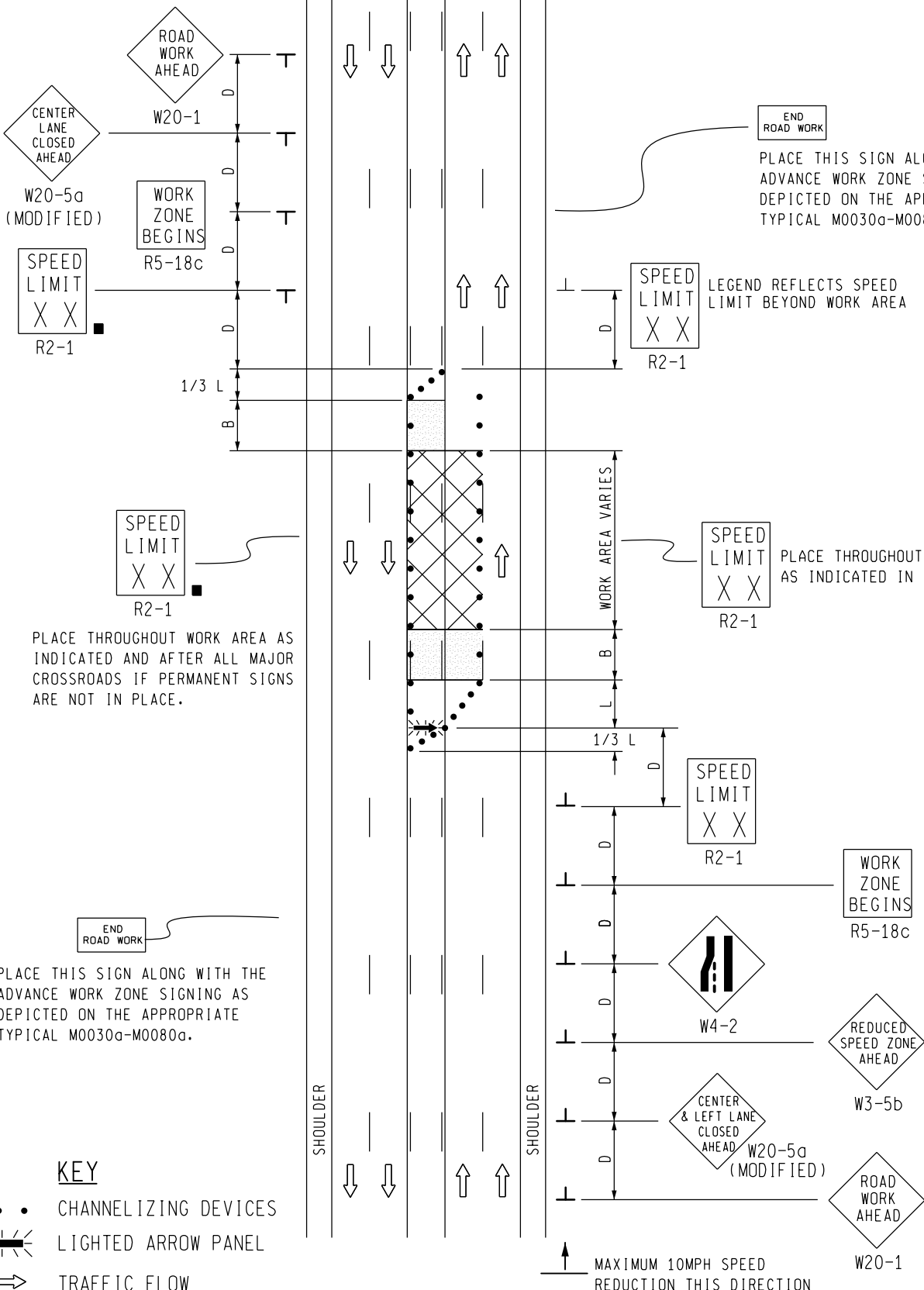

END ROAD WORK
PLACE THIS SIGN ALONG WITH THE
ADVANCE WORK ZONE SIGNING AS
DEPICTED ON THE APPROPRIATE
TYPICAL M0030a-M0080a.

LEGEND REFLECTS SPEED
LIMIT BEYOND WORK AREA

PLACE THROUGHOUT WORK AREA
AS INDICATED IN THE NOTES.

PLACE THROUGHOUT WORK AREA AS
INDICATED AND AFTER ALL MAJOR
CROSSROADS IF PERMANENT SIGNS
ARE NOT IN PLACE.

END ROAD WORK
PLACE THIS SIGN ALONG WITH THE
ADVANCE WORK ZONE SIGNING AS
DEPICTED ON THE APPROPRIATE
TYPICAL M0030a-M0080a.

KEY

- • • CHANNELIZING DEVICES
- ← LIGHTED ARROW PANEL
- ⇒ TRAFFIC FLOW
- REFLECTS EXISTING SPEED LIMIT

SIGN = 188 ft2 - TYPE B
PLUS ADDITIONAL R2-1's
THROUGHOUT WORK AREA

NOT TO SCALE

| | | | |
|--|------------------------------------|--|-------------------------|
| <p>TRAFFIC AND SAFETY MAINTAINING TRAFFIC TYPICAL</p> | | <p>TYPICAL TEMPORARY TRAFFIC CONTROL FOR CLOSING A CENTER-LANE FOR LEFT TURN ONLY AND AN ADJACENT THROUGH LANE ON A MULTI-LANE UNDIVIDED ROADWAY USING A SINGLE STEP DOWN IN SPEED LIMIT IN ONE DIRECTION ONLY</p> | |
| <p>DRAWN BY: CON:AE:djf CHECKED BY: BMM:CRB</p> | <p>OCTOBER 2011 PLAN DATE:</p> | <p>M0350a</p> | <p>SHEET 1 OF 2</p> |
| <p>FILE: PW_RD/TS/Typicals/Signs/MT NON HWY/M0350a.dgn REV. 10/18/2011</p> | | | |

NOTES

- 1D. D = DISTANCE BETWEEN TRAFFIC CONTROL DEVICES
L & 1/3 L = MINIMUM LENGTH OF TAPER
B = LENGTH OF LONGITUDINAL BUFFER
SEE **M0020a** FOR "D," "L," AND "B" VALUES
2. ALL NON-APPLICABLE SIGNING WITHIN THE CIA SHALL BE MODIFIED TO FIT CONDITIONS, COVERED OR REMOVED.
3. DISTANCES BETWEEN SIGNS, THE VALUES FOR WHICH ARE SHOWN IN TABLE D, ARE APPROXIMATE AND MAY NEED ADJUSTING AS DIRECTED BY THE ENGINEER.
- 3A. THE "WORK ZONE BEGINS" (R5-18c) SIGN SHALL BE USED ONLY IN THE INITIAL SIGNING SEQUENCE IN THE WORK ZONE. SUBSEQUENT SEQUENCES IN THE SAME WORK ZONE SHALL OMIT THIS SIGN AND THE QUANTITIES SHALL BE ADJUSTED APPROPRIATELY.
- 4E. THE MAXIMUM RECOMMENDED DISTANCE(S) BETWEEN CHANNELIZING DEVICES SHOULD BE EQUAL IN FEET TO THE POSTED SPEED IN MILES PER HOUR ON TAPER(S) AND TWICE THE POSTED SPEED IN THE PARALLEL AREA(S).
5. FOR OVERNIGHT CLOSURES, TYPE III BARRICADES SHALL BE LIGHTED.
6. WHEN CALLED FOR IN THE FHWA ACCEPTANCE LETTER FOR THE SIGN SYSTEM SELECTED, THE TYPE A WARNING FLASHER, SHOWN ON THE WARNING SIGNS, SHALL BE POSITIONED ON THE SIDE OF THE SIGN NEAREST THE ROADWAY.
7. ALL TEMPORARY SIGNS, TYPE III BARRICADES, THEIR SUPPORT SYSTEMS AND LIGHTING REQUIREMENTS SHALL MEET NCHRP 350 CRASHWORTHLY REQUIREMENTS STIPULATED IN THE CURRENT EDITION OF THE MICHIGAN MANUAL ON UNIFORM TRAFFIC CONTROL DEVICES, THE CURRENT EDITION OF THE STANDARD SPECIFICATIONS FOR CONSTRUCTION, THE STANDARD PLANS AND APPLICABLE SPECIAL PROVISIONS. ONLY DESIGNS AND MATERIALS APPROVED BY MDOT WILL BE ALLOWED.
8. WHEN BUFFER AREAS ARE ESTABLISHED, THERE SHALL BE NO EQUIPMENT OR MATERIALS STORED OR WORK CONDUCTED IN THE BUFFER AREA.
- 16A. ADDITIONAL SPEED LIMIT SIGNS REFLECTING THE REDUCED SPEED SHALL BE PLACED AFTER EACH MAJOR CROSSROAD THAT INTERSECTS THE WORK AREA WHERE THE REDUCED SPEED IS IN EFFECT, AND AT INTERVALS ALONG THE ROADWAY SUCH THAT NO SPEED LIMIT SIGNS REFLECTING THE REDUCED SPEED ARE MORE THAN TWO MILES APART.
- 16B. WHEN REDUCED SPEED LIMITS ARE UTILIZED IN THE WORK AREA, ADDITIONAL SPEED LIMIT SIGNS RETURNING TRAFFIC TO ITS NORMAL SPEED SHALL BE PLACED BEYOND THE LIMITS OF THE REDUCED SPEED AS INDICATED.
- 16E. WHEN EXISTING SPEED LIMITS ARE REDUCED MORE THAN 10 MPH, THE SPEED LIMIT SHALL BE STEPPED DOWN IN NO MORE THAN 10 MPH INCREMENTS.
21. ALL EXISTING PAVEMENT MARKINGS WHICH ARE IN CONFLICT WITH EITHER PROPOSED CHANGES IN TRAFFIC PATTERNS OR PROPOSED TEMPORARY TRAFFIC MARKINGS, SHALL BE REMOVED BEFORE ANY CHANGE IS MADE IN THE TRAFFIC PATTERN. EXCEPTION WILL BE MADE FOR DAYTIME-ONLY TRAFFIC PATTERNS THAT ARE ADEQUATELY DELINEATED BY OTHER TRAFFIC CONTROL DEVICES.
- 26C. THE LIGHTED ARROW PANEL SHALL BE LOCATED AT THE BEGINNING OF THE MERGING TAPER AS SHOWN. WHEN PHYSICAL LIMITATIONS RESTRICT ITS PLACEMENT AS INDICATED, THEN IT SHALL BE PLACED AS CLOSE TO THE BEGINNING OF THE MERGING TAPER AS POSSIBLE.

SIGN SIZES

DIAMOND WARNING - 48" x 48"
 RECTANGULAR REGULATORY - 48" x 60"
 R5-18c REGULATORY - 48" x 48"

NOT TO SCALE

| | | | |
|---|--|--------------|--------|
|  TRAFFIC AND SAFETY MAINTAINING TRAFFIC TYPICAL | TYPICAL TEMPORARY TRAFFIC CONTROL FOR CLOSING A CENTER-LANE FOR LEFT TURN ONLY AND AN ADJACENT THROUGH LANE ON A MULTI-LANE UNDIVIDED ROADWAY USING A SINGLE STEP DOWN IN SPEED LIMIT IN ONE DIRECTION ONLY | | |
| | DRAWN BY: CON:AE:djf | OCTOBER 2011 | SHEET |
| CHECKED BY: BMM:CRB | PLAN DATE: | M0350a | 2 OF 2 |
| FILE: PW_RD/TS/Typicals/Signs/MT NON HWY/M0350a.dgn REV. 10/18/2011 | | | |

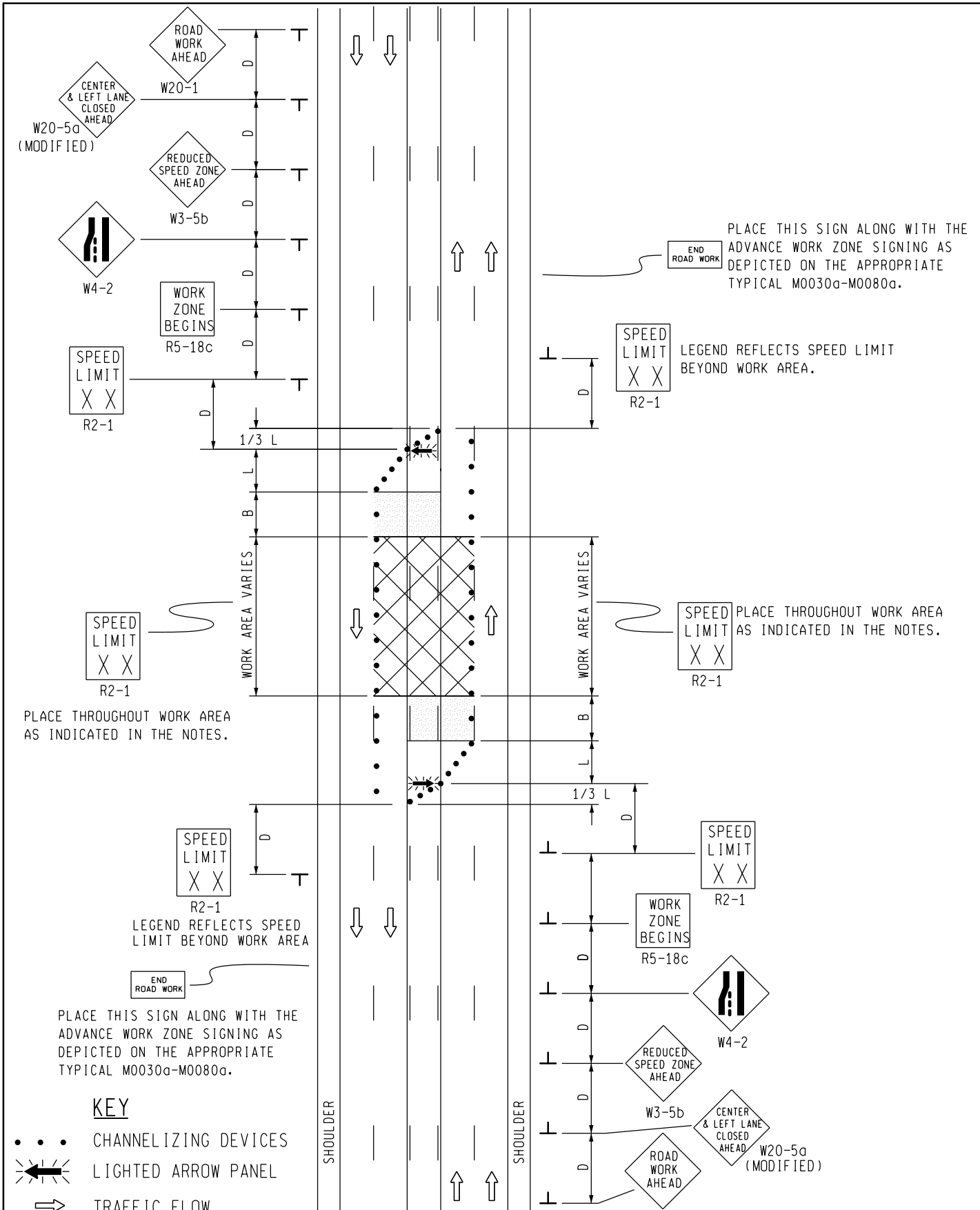

PLACE THIS SIGN ALONG WITH THE ADVANCE WORK ZONE SIGNING AS DEPICTED ON THE APPROPRIATE TYPICAL M0030a-M0080a.

LEGEND REFLECTS SPEED LIMIT BEYOND WORK AREA.

PLACE THROUGHOUT WORK AREA AS INDICATED IN THE NOTES.

LEGEND REFLECTS SPEED LIMIT BEYOND WORK AREA

PLACE THIS SIGN ALONG WITH THE ADVANCE WORK ZONE SIGNING AS DEPICTED ON THE APPROPRIATE TYPICAL M0030a-M0080a.

KEY

- • • CHANNELIZING DEVICES
- ← LIGHTED ARROW PANEL
- TRAFFIC FLOW

SIGN = 240 ft x 2 - TYPE B PLUS ADDITIONAL R2-1's THROUGHOUT WORK AREA

| | | | |
|--|------------------------------------|--|-------------------------|
| <p>TRAFFIC AND SAFETY MAINTAINING TRAFFIC TYPICAL</p> | | <p>TYPICAL TEMPORARY TRAFFIC CONTROL FOR CLOSING A CENTER-LANE FOR LEFT TURN ONLY AND AN ADJACENT THROUGH LANE IN EACH DIRECTION ON A MULTI-LANE UNDIVIDED ROADWAY USING A SINGLE STEP DOWN IN SPEED LIMIT</p> | |
| <p>DRAWN BY: CON:AE:djf CHECKED BY: BMM:CRB</p> | <p>OCTOBER 2011 PLAN DATE:</p> | <p>M0380a</p> | <p>SHEET 1 OF 2</p> |
| <p>FILE: PW_RD/TS/Typicals/Signs/MT_NON_Fwy/M0380a.dgn REV. 10/18/2011</p> | | | |

NOT TO SCALE

NOTES

- 1D. D = DISTANCE BETWEEN TRAFFIC CONTROL DEVICES
L & 1/3 L = MINIMUM LENGTH OF TAPER
B = LENGTH OF LONGITUDINAL BUFFER
SEE **M0020a** FOR "D," "L," AND "B" VALUES
2. ALL NON-APPLICABLE SIGNING WITHIN THE CIA SHALL BE MODIFIED TO FIT CONDITIONS, COVERED OR REMOVED.
3. DISTANCES BETWEEN SIGNS, THE VALUES FOR WHICH ARE SHOWN IN TABLE D, ARE APPROXIMATE AND MAY NEED ADJUSTING AS DIRECTED BY THE ENGINEER.
- 3A. THE "WORK ZONE BEGINS" (R5-18c) SIGN SHALL BE USED ONLY IN THE INITIAL SIGNING SEQUENCE IN THE WORK ZONE. SUBSEQUENT SEQUENCES IN THE SAME WORK ZONE SHALL OMIT THIS SIGN AND THE QUANTITIES SHALL BE ADJUSTED APPROPRIATELY.
- 4E. THE MAXIMUM RECOMMENDED DISTANCE(S) BETWEEN CHANNELIZING DEVICES SHOULD BE EQUAL IN FEET TO THE POSTED SPEED IN MILES PER HOUR ON TAPER(S) AND TWICE THE POSTED SPEED IN THE PARALLEL AREA(S).
5. FOR OVERNIGHT CLOSURES, TYPE III BARRICADES SHALL BE LIGHTED.
6. WHEN CALLED FOR IN THE FHWA ACCEPTANCE LETTER FOR THE SIGN SYSTEM SELECTED, THE TYPE A WARNING FLASHER, SHOWN ON THE WARNING SIGNS, SHALL BE POSITIONED ON THE SIDE OF THE SIGN NEAREST THE ROADWAY.
7. ALL TEMPORARY SIGNS, TYPE III BARRICADES, THEIR SUPPORT SYSTEMS AND LIGHTING REQUIREMENTS SHALL MEET NCHRP 350 CRASHWORTHLY REQUIREMENTS STIPULATED IN THE CURRENT EDITION OF THE MICHIGAN MANUAL ON UNIFORM TRAFFIC CONTROL DEVICES, THE CURRENT EDITION OF THE STANDARD SPECIFICATIONS FOR CONSTRUCTION, THE STANDARD PLANS AND APPLICABLE SPECIAL PROVISIONS. ONLY DESIGNS AND MATERIALS APPROVED BY MDOT WILL BE ALLOWED.
8. WHEN BUFFER AREAS ARE ESTABLISHED, THERE SHALL BE NO EQUIPMENT OR MATERIALS STORED OR WORK CONDUCTED IN THE BUFFER AREA.
- 16A. ADDITIONAL SPEED LIMIT SIGNS REFLECTING THE REDUCED SPEED SHALL BE PLACED AFTER EACH MAJOR CROSSROAD THAT INTERSECTS THE WORK AREA WHERE THE REDUCED SPEED IS IN EFFECT, AND AT INTERVALS ALONG THE ROADWAY SUCH THAT NO SPEED LIMIT SIGNS REFLECTING THE REDUCED SPEED ARE MORE THAN TWO MILES APART.
- 16B. WHEN REDUCED SPEED LIMITS ARE UTILIZED IN THE WORK AREA, ADDITIONAL SPEED LIMIT SIGNS RETURNING TRAFFIC TO ITS NORMAL SPEED SHALL BE PLACED BEYOND THE LIMITS OF THE REDUCED SPEED AS INDICATED.
- 16E. WHEN EXISTING SPEED LIMITS ARE REDUCED MORE THAN 10 MPH, THE SPEED LIMIT SHALL BE STEPPED DOWN IN NO MORE THAN 10 MPH INCREMENTS.
21. ALL EXISTING PAVEMENT MARKINGS WHICH ARE IN CONFLICT WITH EITHER PROPOSED CHANGES IN TRAFFIC PATTERNS OR PROPOSED TEMPORARY TRAFFIC MARKINGS, SHALL BE REMOVED BEFORE ANY CHANGE IS MADE IN THE TRAFFIC PATTERN. EXCEPTION WILL BE MADE FOR DAYTIME-ONLY TRAFFIC PATTERNS THAT ARE ADEQUATELY DELINEATED BY OTHER TRAFFIC CONTROL DEVICES.
- 26C. THE LIGHTED ARROW PANEL SHALL BE LOCATED AT THE BEGINNING OF THE MERGING TAPER AS SHOWN. WHEN PHYSICAL LIMITATIONS RESTRICT ITS PLACEMENT AS INDICATED, THEN IT SHALL BE PLACED AS CLOSE TO THE BEGINNING OF THE MERGING TAPER AS POSSIBLE.

SIGN SIZES

| | |
|------------------------|-------------|
| DIAMOND WARNING | - 48" x 48" |
| RECTANGULAR REGULATORY | - 48" x 60" |
| R5-18c REGULATORY | - 48" x 48" |

NOT TO SCALE

| | | | |
|---|--|--------------|--------|
|  TRAFFIC AND SAFETY MAINTAINING TRAFFIC TYPICAL | TYPICAL TEMPORARY TRAFFIC CONTROL FOR CLOSING A CENTER-LANE FOR LEFT TURN ONLY AND AN ADJACENT THROUGH LANE IN EACH DIRECTION ON A MULTI-LANE UNDIVIDED ROADWAY USING A SINGLE STEP DOWN IN SPEED LIMIT | | |
| | DRAWN BY: CON:AE:djf | OCTOBER 2011 | M0380a |
| CHECKED BY: BMM:CRB | PLAN DATE: | 2 OF 2 | |
| FILE: PW_RD/TS/Typicals/Signs/MT NON FWY/M0380a.dgn REV. 10/18/2011 | | | |

KEY

- • • CHANNELIZING DEVICES
- ☀ TYPE A WARNING FLASHER (REQUIRED)
- ➡ TRAFFIC FLOW
- REFLECTS EXISTING SPEED LIMIT

SIGN = 184 ft± - TYPE B PLUS ADDITIONAL R2-1's THROUGHOUT WORK AREA

PLACE THIS SIGN ALONG WITH THE ADVANCE WORK ZONE SIGNING AS DEPICTED ON THE APPROPRIATE TYPICAL M0030a-M0080a.

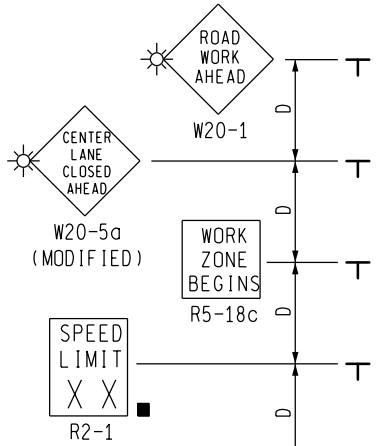

1/3 L

TEMPORARY PAVEMENT MARKINGS



PLACE THROUGHOUT WORK AREA AS INDICATED AND AFTER ALL MAJOR CROSSROADS IF PERMANENT SIGNS ARE NOT IN PLACE.

1/2 L



PLACE THIS SIGN ALONG WITH THE ADVANCE WORK ZONE SIGNING AS DEPICTED ON THE APPROPRIATE TYPICAL M0030a-M0080a.

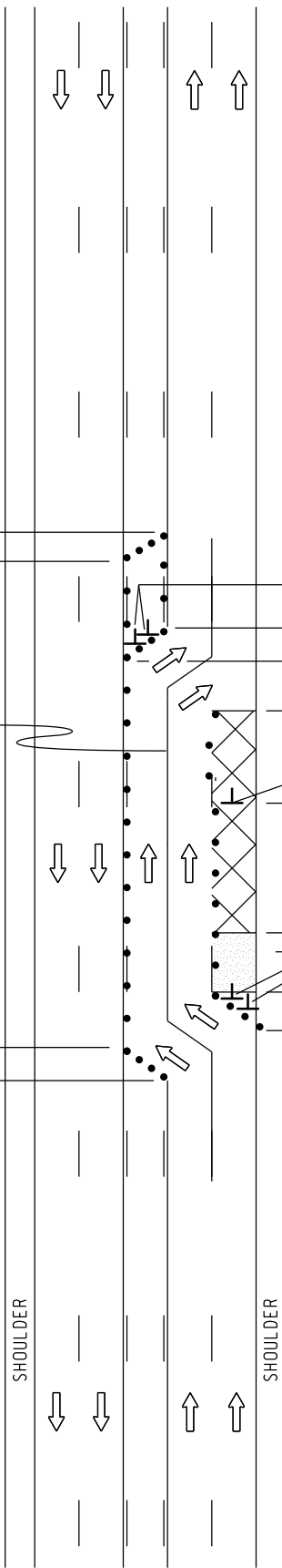

1/2 L

1/2 D

D

WORK AREA VARIES

1/2 L

D

1/2 L

2D

D

D

D

D

D

D

D

D

D

D

D

D

D

D

D

D

D

D

D

D

D

D

D

D

D

D

D

D

D

D

D

D

D

D

MDOT
Michigan Department of Transportation
TRAFFIC AND SAFETY
MAINTAINING TRAFFIC
TYPICAL

TYPICAL TEMPORARY TRAFFIC CONTROL FOR CLOSING ONE LANE OF A FIVE-LANE UNDIVIDED ROADWAY AND MAINTAINING TWO THROUGH LANES IN EACH DIRECTION, NO SPEED REDUCTION

DRAWN BY: CON:AE:djf
CHECKED BY: BMM:CRB

OCTOBER 2011
PLAN DATE:

M0400a

SHEET 1 OF 2

NOT TO SCALE

NOTES

- 1F. D = DISTANCE BETWEEN TRAFFIC CONTROL DEVICES
 $1/2 L$, AND $1/3 L$ = MINIMUM LENGTH OF TAPER
 B = LENGTH OF LONGITUDINAL BUFFER
 SEE M0020a FOR "D," "L," AND "B" VALUES
2. ALL NON-APPLICABLE SIGNING WITHIN THE CIA SHALL BE MODIFIED TO FIT CONDITIONS, COVERED OR REMOVED.
3. DISTANCES BETWEEN SIGNS, THE VALUES FOR WHICH ARE SHOWN IN TABLE D, ARE APPROXIMATE AND MAY NEED ADJUSTING AS DIRECTED BY THE ENGINEER.
- 3A. THE "WORK ZONE BEGINS" (R5-18c) SIGN SHALL BE USED ONLY IN THE INITIAL SIGNING SEQUENCE IN THE WORK ZONE. SUBSEQUENT SEQUENCES IN THE SAME WORK ZONE SHALL OMIT THIS SIGN AND THE QUANTITIES SHALL BE ADJUSTED APPROPRIATELY.
- 4E. THE MAXIMUM RECOMMENDED DISTANCE(S) BETWEEN CHANNELIZING DEVICES SHOULD BE EQUAL IN FEET TO THE POSTED SPEED IN MILES PER HOUR ON TAPER(S) AND TWICE THE POSTED SPEED IN THE PARALLEL AREA(S).
5. FOR OVERNIGHT CLOSURES, TYPE III BARRICADES SHALL BE LIGHTED.
6. THE TYPE A WARNING FLASHER SHOWN ON THE WARNING SIGNS SHALL BE POSITIONED ON THE SIDE OF THE SIGN NEAREST THE ROADWAY.
7. ALL TEMPORARY SIGNS, TYPE III BARRICADES, THEIR SUPPORT SYSTEMS AND LIGHTING REQUIREMENTS SHALL MEET NCHRP 350 CRASHWORTHLY REQUIREMENTS STIPULATED IN THE CURRENT EDITION OF THE MICHIGAN MANUAL ON UNIFORM TRAFFIC CONTROL DEVICES, THE CURRENT EDITION OF THE STANDARD SPECIFICATIONS FOR CONSTRUCTION, THE STANDARD PLANS AND APPLICABLE SPECIAL PROVISIONS. ONLY DESIGNS AND MATERIALS APPROVED BY MDOT WILL BE ALLOWED.
8. WHEN BUFFER AREAS ARE ESTABLISHED, THERE SHALL BE NO EQUIPMENT OR MATERIALS STORED OR WORK CONDUCTED IN THE BUFFER AREA.
21. ALL EXISTING PAVEMENT MARKINGS WHICH ARE IN CONFLICT WITH EITHER PROPOSED CHANGES IN TRAFFIC PATTERNS OR PROPOSED TEMPORARY TRAFFIC MARKINGS, SHALL BE REMOVED BEFORE ANY CHANGE IS MADE IN THE TRAFFIC PATTERN. EXCEPTION WILL BE MADE FOR DAYTIME-ONLY TRAFFIC PATTERNS THAT ARE ADEQUATELY DELINEATED BY OTHER TRAFFIC CONTROL DEVICES.

SIGN SIZES

| | |
|-------------------|-------------|
| DIAMOND WARNING | - 48" x 48" |
| W1-6 WARNING | - 48" x 24" |
| R2-1 REGULATORY | - 48" x 60" |
| R5-18c REGULATORY | - 48" x 48" |

NOT TO SCALE

| | | |
|---|---|----------------------------|
|  TRAFFIC AND SAFETY MAINTAINING TRAFFIC TYPICAL | TYPICAL TEMPORARY TRAFFIC CONTROL FOR CLOSING ONE LANE OF A FIVE-LANE UNDIVIDED ROADWAY AND MAINTAINING TWO THROUGH LANES IN EACH DIRECTION, NO SPEED REDUCTION | |
| | DRAWN BY: CON:AE:djf CHECKED BY: BMM:CRB | OCTOBER 2011 PLAN DATE: |
| FILE: K:\-DGN-TSR-STD5-ENGLISH-MNTTRF-M0400a.dgn | | |
| | | REV. 10/19/2011 |

SIGN MATERIAL SELECTION TABLE

| SIGN SIZE | SIGN MATERIAL TYPE | | |
|--------------------------|--------------------|---------|----------|
| | TYPE I | TYPE II | TYPE III |
| ≤ 36" X 36" | | X | X |
| >36" X 36" < 96" TO WIDE | | X | |
| > 96" WIDE TO 144" WIDE | X | X | |
| > 144" WIDE | X | | |

TYPE I ALUMINUM EXTRUSION
 TYPE II PLYWOOD
 TYPE III ALUMINUM SHEET

ROUNDING OF CORNERS IS NOT REQUIRED FOR TYPE I OR II SIGNS.
 VERTICAL JOINTS ARE NOT PERMITTED.
 HORIZONTAL JOINTS THROUGH SIGN LEGEND OR SYMBOLS ARE NOT PERMITTED.

POST SIZE REQUIREMENTS TABLE

| SIGN AREA (ft ²) | POST TYPE | | |
|---------------------------------|-----------------|----------------------|--------------|
| | U-CHANNEL STEEL | SQUARE TUBULAR STEEL | WOOD |
| ≤9 | 1 - 3 lb/ft* | 1 - 2" 12 or 14 GA* | N/A |
| 9 ≤ 20 | 2 - 3 lb/ft | 2 - 2" 12 or 14 GA | 1 - 4" X 6"* |
| > 20 ≤ 30 | N/A | N/A | 2 - 4" X 6" |
| > 30 ≤ 60 | N/A | N/A | 2 - 6" X 8" |
| > 60 ≤ 84 | N/A | N/A | 3 - 6" X 8" |

*SIGNS 4 FEET AND GREATER IN WIDTH REQUIRE 2 POSTS.
 SIGNS GREATER THAN 8 FEET IN WIDTH REQUIRE 2 OR 3 WOOD
 POSTS DEPENDING ON AREA OF SIGN.
 A MAXIMUM OF 2 POSTS WITHIN A 7' PATH IS PERMITTED.

| | | | | |
|---|--|---|----------------------------|-------------------------------|
|  PREPARED BY OPERATIONS FIELD SERVICES | DEPARTMENT DIRECTOR Kirk T. Steudle APPROVED BY: _____ DIRECTOR, BUREAU OF FIELD SERVICES | MICHIGAN DEPARTMENT OF TRANSPORTATION BUREAU OF FIELD SERVICES SPECIAL DETAIL FOR GROUND DRIVEN SIGN SUPPORTS FOR TEMP SIGNS | | |
| | DRAWN BY: <u>CON/ECH</u> CHECKED BY: <u>AUG</u> | APPROVED BY: _____ DIRECTOR, BUREAU OF HIGHWAY DEVELOPMENT | _____ F.H.W.A. APPROVAL | <u>7/20/2016</u> PLAN DATE |

2 POST SIGN SUPPORT SPACING

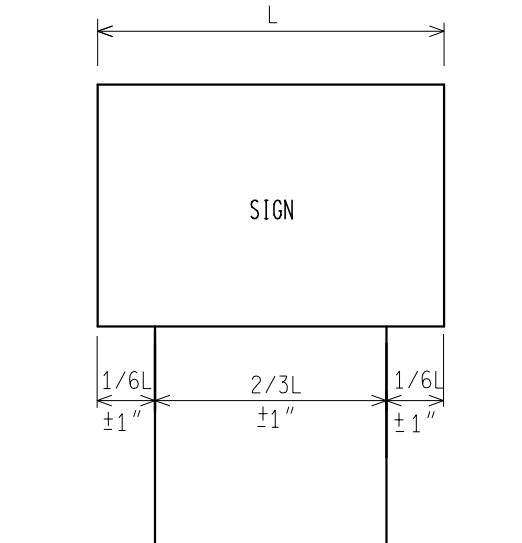

3 POST SIGN SUPPORT SPACING

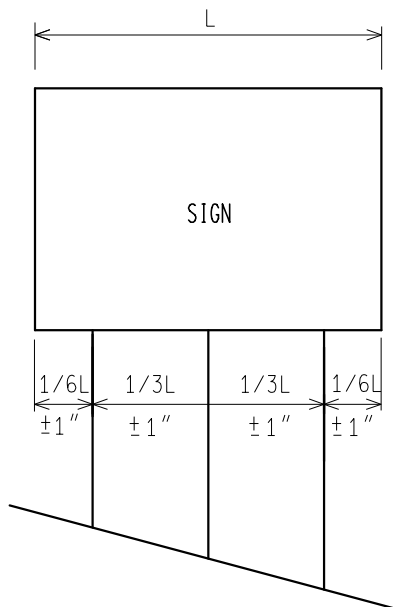

* FOR ALL 11' AND 12' LONG SIGNS ON 3 WOOD SUPPORTS, SPREAD POSTS SO AS TO HAVE A 8' MIN. TO 9' MAX. DISTANCE BETWEEN OUTSIDE POSTS.

NOT TO SCALE

MICHIGAN DEPARTMENT OF TRANSPORTATION
BUREAU OF FIELD SERVICES SPECIAL DETAIL

F.H.W.A. APPROVAL

7/20/2016
PLAN DATE

WZD-100-A

SHEET
2 OF 11

NOTE: THE ORIGINAL SIGNED COPY IS KEPT ON FILE AT THE MICHIGAN DEPARTMENT OF TRANSPORTATION.

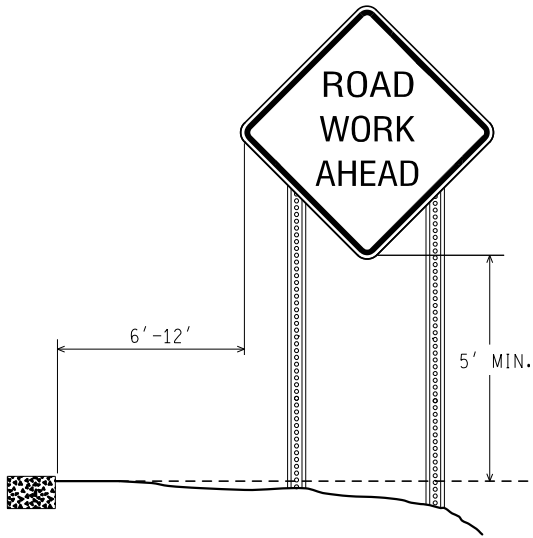

RURAL

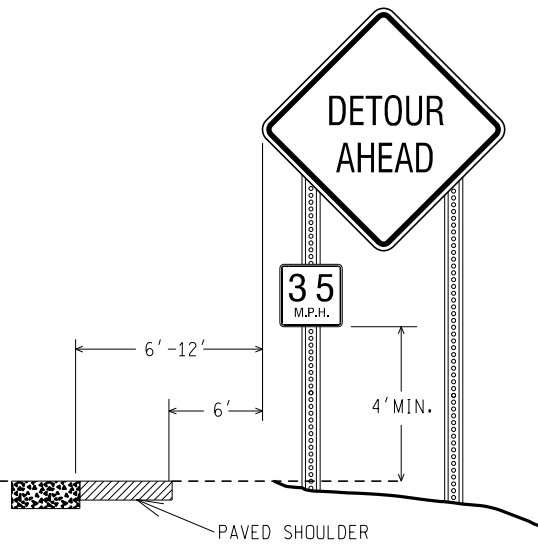

RURAL WITH ADVISORY SPEED PLATE

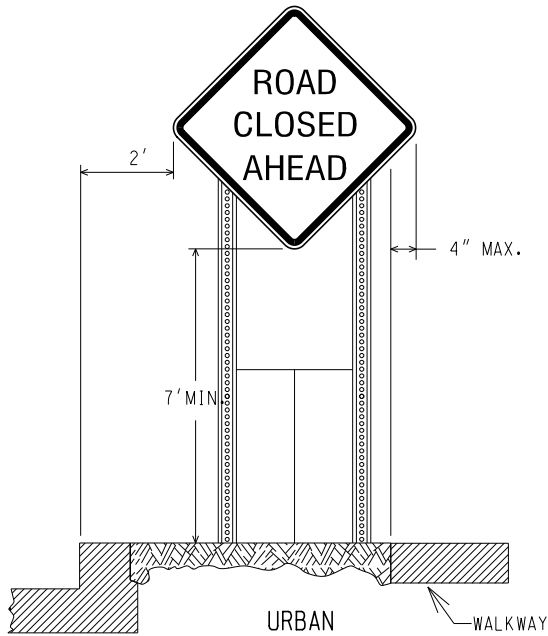

URBAN

WALKWAY

(CURBED AREAS OR WHERE WALKWAYS ARE PRESENT)

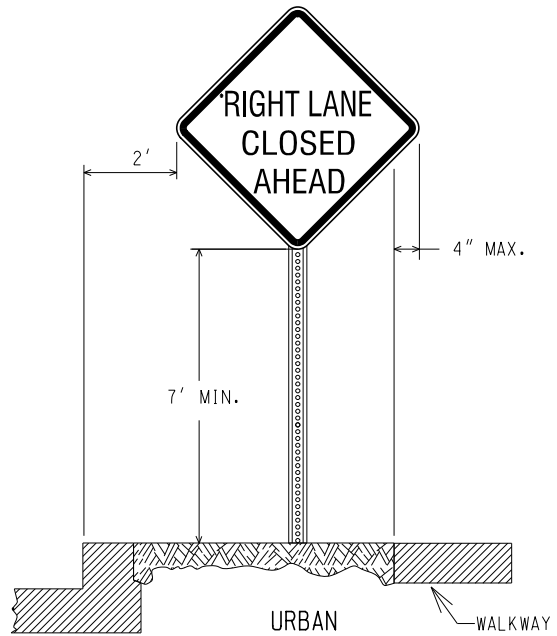

URBAN

WALKWAY

(CURBED AREAS OR WHERE WALKWAYS ARE PRESENT)

BOTTOM HEIGHT AND OFFSET

NOT TO SCALE

MICHIGAN DEPARTMENT OF TRANSPORTATION
BUREAU OF FIELD SERVICES SPECIAL DETAIL

F.H.W.A. APPROVAL

7/20/2016
PLAN DATE

WZD-100-A

SHEET
3 OF 11

NOTE: THE ORIGINAL SIGNED COPY IS KEPT ON FILE AT THE MICHIGAN DEPARTMENT OF TRANSPORTATION.

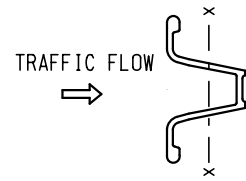
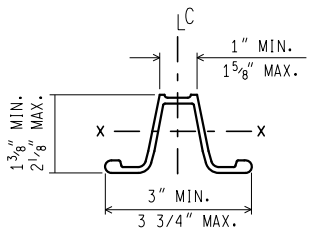
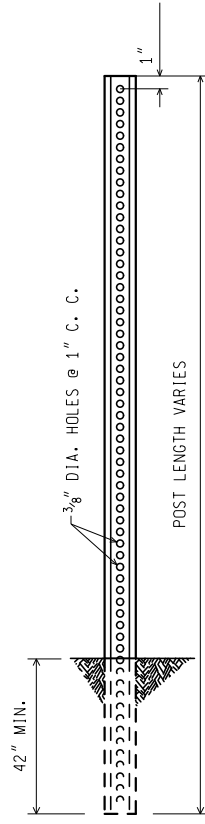

WEIGHT = 3 lbs/ft
 SECT. MOD. X.-X. = 0.31 CUBIC INCHES MIN.

3 lb. U - CHANNEL STEEL POST
 (NO SPLICE)

MOUNT SIGN ON OPEN FACE OF
 U - CHANNEL STEEL POST

NOT TO SCALE

| | | | | |
|--|-------------------|------------------------|-----------|------------------|
| MICHIGAN DEPARTMENT OF TRANSPORTATION BUREAU OF FIELD SERVICES SPECIAL DETAIL | F.H.W.A. APPROVAL | 7/20/2016 PLAN DATE | WZD-100-A | SHEET 4 OF 11 |
|--|-------------------|------------------------|-----------|------------------|

NOTE: THE ORIGINAL SIGNED COPY IS KEPT ON FILE AT THE MICHIGAN DEPARTMENT OF TRANSPORTATION.

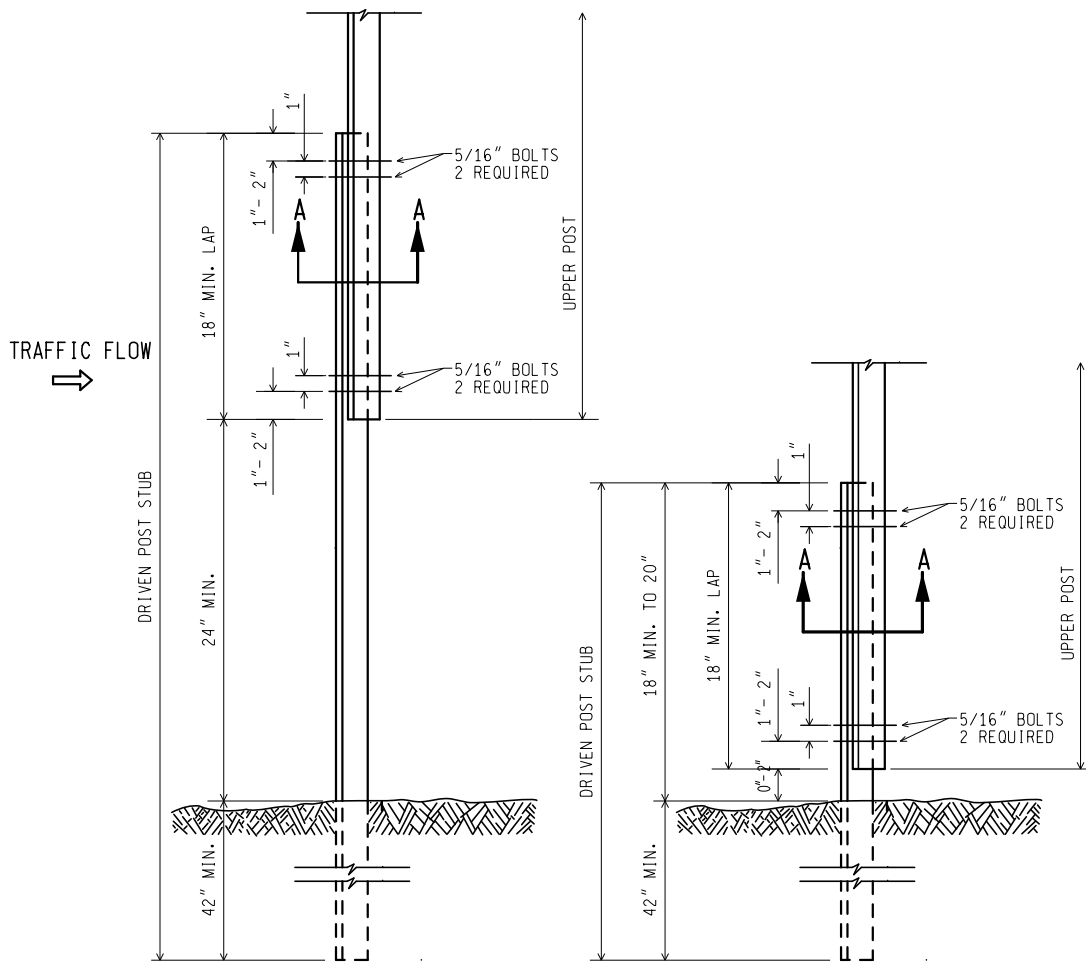

3 lb. U - CHANNEL STEEL POST
(WITH SPLICE)

MOUNT SIGN ON OPEN FACE OF
UPPER U - CHANNEL STEEL POST

NOT TO SCALE

MICHIGAN DEPARTMENT OF TRANSPORTATION
BUREAU OF FIELD SERVICES SPECIAL DETAIL

F.H.W.A. APPROVAL

7/20/2016
PLAN DATE

WZD-100-A

SHEET
5 OF 11

NOTE: THE ORIGINAL SIGNED COPY IS KEPT ON FILE AT THE MICHIGAN DEPARTMENT OF TRANSPORTATION.

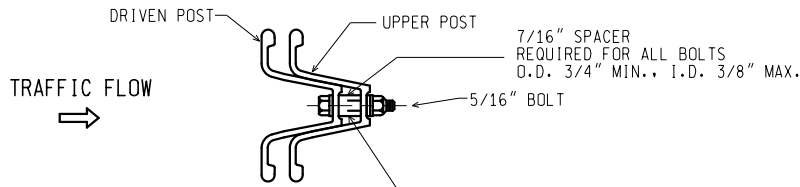

SECTION A-A

7/16" SPACER
 REQUIRED FOR ALL BOLTS
 O.D. 3/4" MIN., I.D. 3/8" MAX.

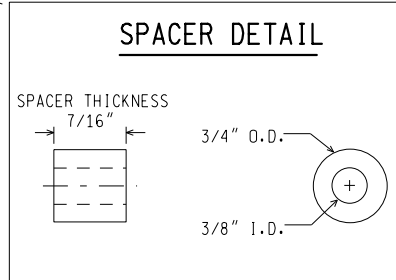

NOTES:

1. THE SPACER THICKNESS SHALL BE 1/16" LESS THAN THE GAP BETWEEN THE POST WHEN POSITIONED IN THE UNBOLTED CONFIGURATION.
2. THE EXTERIOR BOLT (CLOSEST TO LAP), SPACER, WASHER, AND NUT SHALL BE INSTALLED IN A PREPUNCHED HOLE 1" TO 2" FROM THE END OF THE LAP.
3. THE INTERIOR BOLT (FARTHEST FROM LAP), SPACER, WASHER, AND NUT SHALL BE INSTALLED IN THE NEXT PREPUNCHED HOLE.
4. THE DRIVEN POST SHALL ALWAYS BE MOUNTED IN FRONT OF THE UPPER POST WITH RESPECT TO THE ADJACENT ONCOMING TRAFFIC, REGARDLESS OF THE DIRECTION THE SIGN IS FACING.
5. THE SPLICE LAP SHALL BE FASTENED BY FOUR-5/16" DIA. GALVANIZED A449 BOLTS (SAE J429 GRADE 5) OR GALVANIZED A325 BOLTS.

3 lb. U - CHANNEL STEEL POST
 (WITH SPLICE)

NOT TO SCALE

| | | | | |
|--|-------------------|------------------------|-----------|------------------|
| MICHIGAN DEPARTMENT OF TRANSPORTATION BUREAU OF FIELD SERVICES SPECIAL DETAIL | F.H.W.A. APPROVAL | 7/20/2016 PLAN DATE | WZD-100-A | SHEET 6 OF 11 |
|--|-------------------|------------------------|-----------|------------------|

NOTE: THE ORIGINAL SIGNED COPY IS KEPT ON FILE AT THE MICHIGAN DEPARTMENT OF TRANSPORTATION.

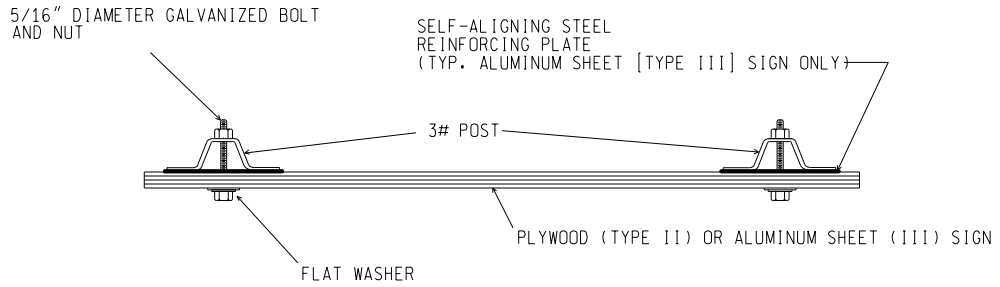

SIGN TO 3 lb. POST CONNECTION

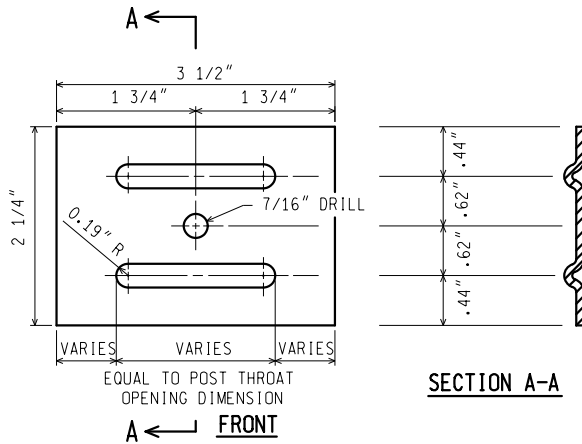

NOTES: (FOR STEEL SIGN REINF' PLATE)

1. MATERIAL: 12 GAUGE CARBON STEEL.
2. TOLERANCE ON ALL DIMENSIONS $\pm 0.0625"$
3. FINISH-AFTER STAMPING AND PUNCHING, GALVANIZE ACCORDING TO CURRENT SPECIFICATIONS FOR ZINC (HOT GALVANIZE) COATINGS ON PRODUCTS FABRICATED FROM PLATES OR STRIPS

STEEL SIGN REINFORCING PLATE
REQUIRED FOR TYPE III SIGNS ONLY

3 lb. U - CHANNEL STEEL POST SIGN CONNECTION

NOT TO SCALE

MICHIGAN DEPARTMENT OF TRANSPORTATION
 BUREAU OF FIELD SERVICES SPECIAL DETAIL

F.H.W.A. APPROVAL

7/20/2016
 PLAN DATE

WZD-100-A

SHEET
 7 OF 11

NOTE: THE ORIGINAL SIGNED COPY IS KEPT ON FILE AT THE MICHIGAN DEPARTMENT OF TRANSPORTATION.

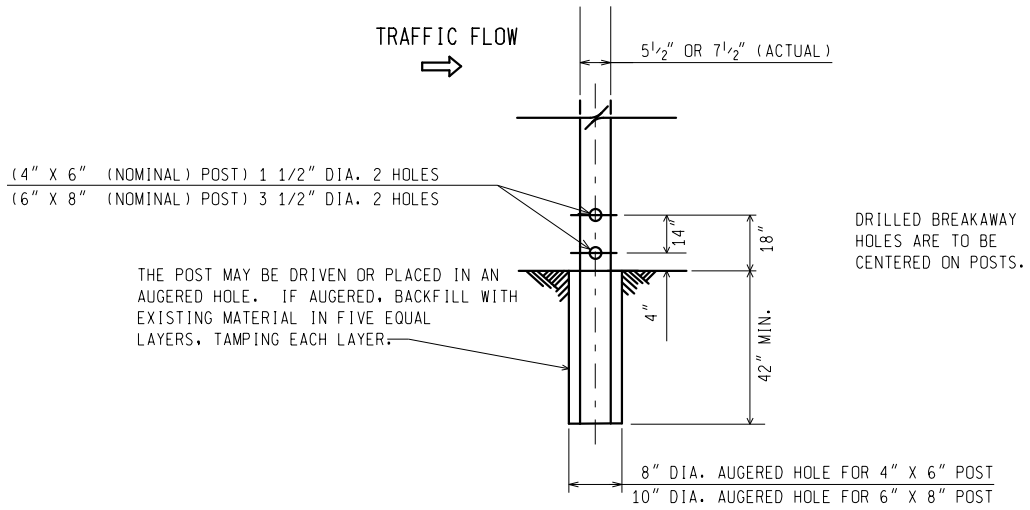

WOOD POST BREAKAWAY HOLES/
 DIRECT EMBEDMENT DETAILS

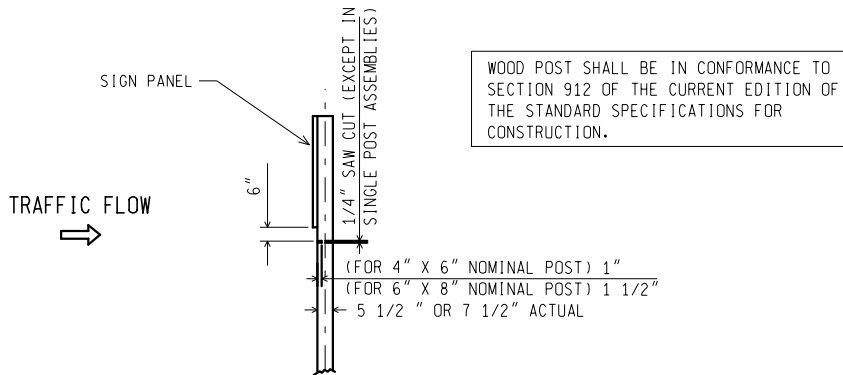

SAW CUT DETAIL
 (MULTIPLE POST INSTALLATIONS)

WOOD POST DETAILS

NOT TO SCALE

| | | | | |
|--|-------------------|------------------------|-----------|------------------|
| MICHIGAN DEPARTMENT OF TRANSPORTATION BUREAU OF FIELD SERVICES SPECIAL DETAIL | F.H.W.A. APPROVAL | 7/20/2016 PLAN DATE | WZD-100-A | SHEET 8 OF 11 |
|--|-------------------|------------------------|-----------|------------------|

NOTE: THE ORIGINAL SIGNED COPY IS KEPT ON FILE AT THE MICHIGAN DEPARTMENT OF TRANSPORTATION.

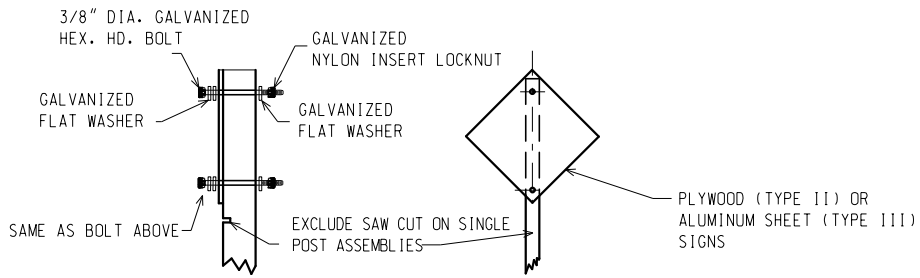

TYPE II AND TYPE III SIGNS

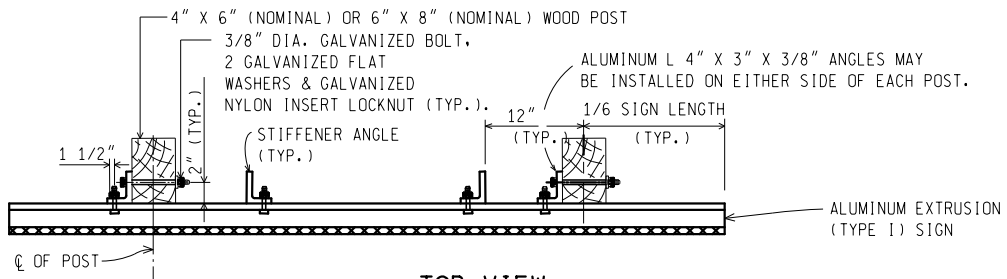

**TOP VIEW
TYPE I SIGN**

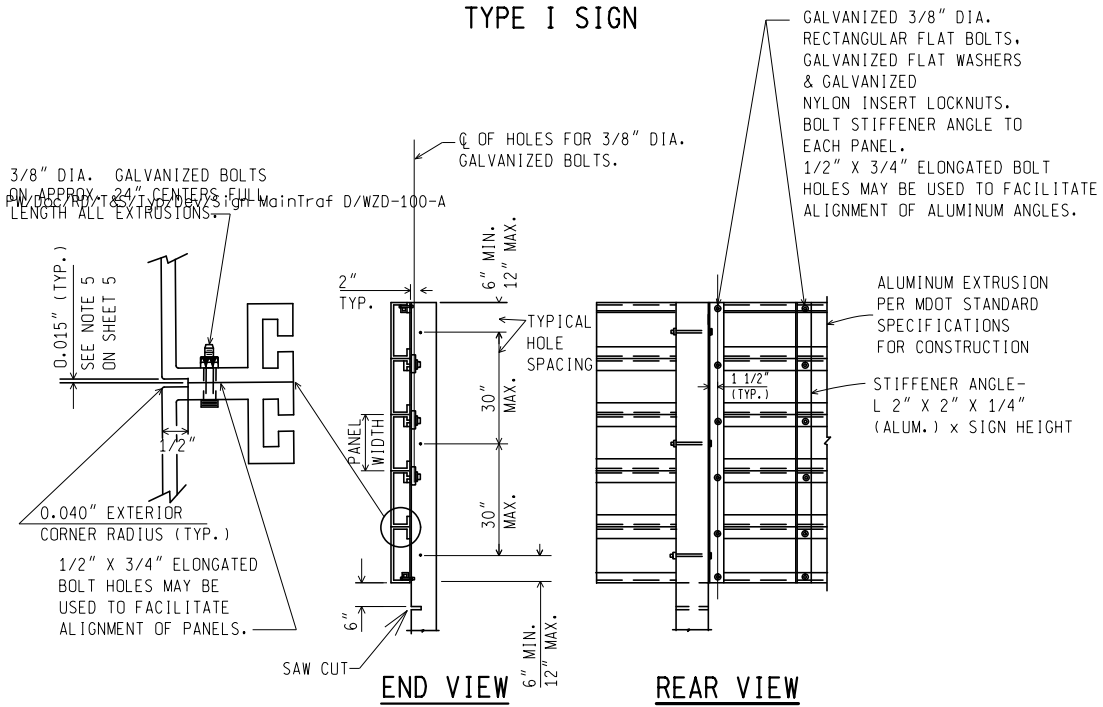

TYPE I SIGN - ERECTION DETAILS

WOOD POST CONNECTIONS

NOT TO SCALE

MICHIGAN DEPARTMENT OF TRANSPORTATION
BUREAU OF FIELD SERVICES SPECIAL DETAIL

F.H.W.A. APPROVAL

7/20/2016
PLAN DATE

WZD-100-A

SHEET
9 OF 11

NOTE: THE ORIGINAL SIGNED COPY IS KEPT ON FILE AT THE MICHIGAN DEPARTMENT OF TRANSPORTATION.

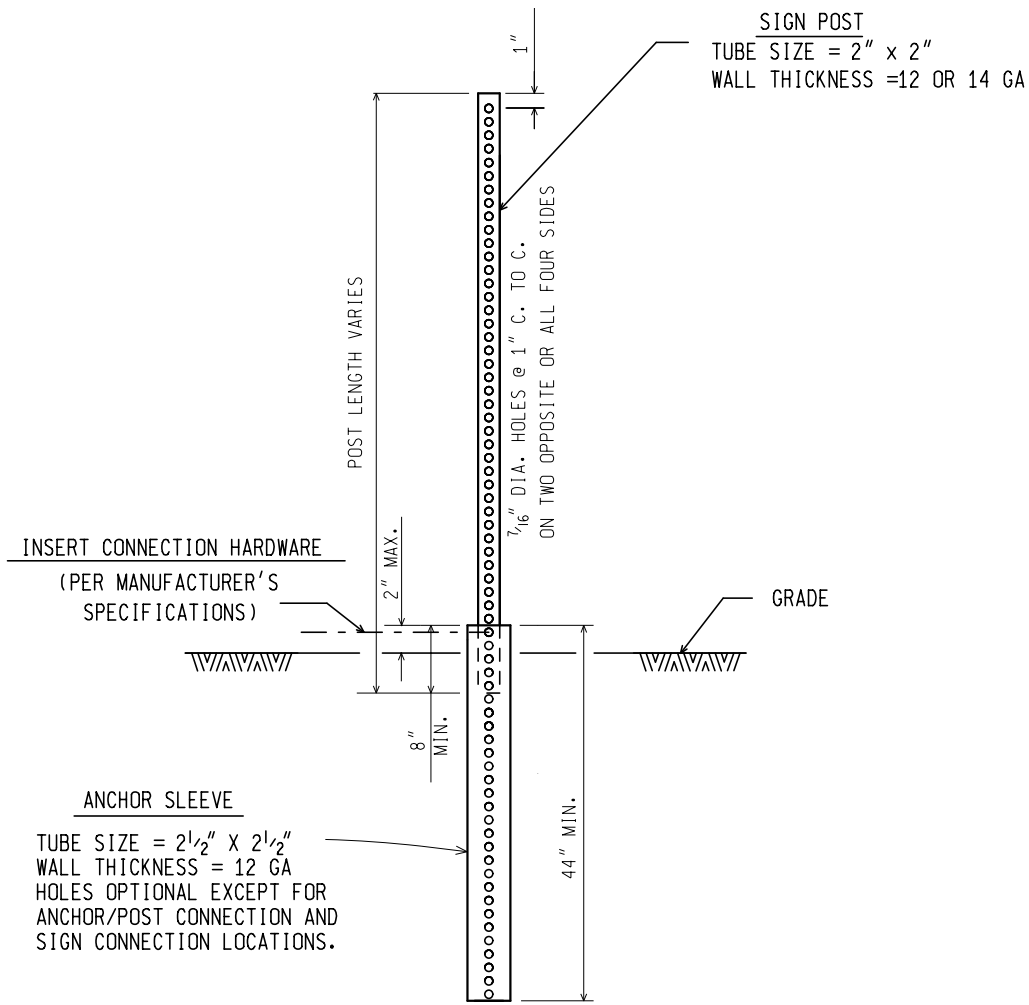

SQUARE TUBULAR STEEL POST

NOT TO SCALE

| | | | | |
|--|-------------------|------------------------|-----------|-------------------|
| MICHIGAN DEPARTMENT OF TRANSPORTATION BUREAU OF FIELD SERVICES SPECIAL DETAIL | F.H.W.A. APPROVAL | 7/20/2016 PLAN DATE | WZD-100-A | SHEET 10 OF 11 |
|--|-------------------|------------------------|-----------|-------------------|

NOTE: THE ORIGINAL SIGNED COPY IS KEPT ON FILE AT THE MICHIGAN DEPARTMENT OF TRANSPORTATION.

GENERAL NOTES:

1. A MAXIMUM OF TWO POSTS WITHIN A 7 FOOT PATH IS PERMITTED.
2. ALL SIGN POSTS SHALL COMPLY WITH NCHRP 350.
3. ALL POSTS SHALL BE EMBEDDED A MINIMUM OF 42".
4. BRACING OF POST IS NOT PERMITTED.
5. SIGN SHALL BE LEVEL, AND UPRIGHT FOR THE DURATION OF INSTALLATION.
6. ERECT POSTS SO THE SIGN FACE AND SUPPORTS DO NOT VARY FROM PLUMB BY MORE THAN 3/16" IN 3'. PROVIDE A CENTER-TO-CENTER DISTANCE BETWEEN POSTS WITHIN 2 PERCENT OF PLAN DISTANCE.
7. NO MORE THAN ONE SPLICE PER POST, AS SHOWN, WILL BE PERMITTED.
8. POST TYPES SHALL NOT BE MIXED WITHIN A SIGN SUPPORT INSTALLATION.
9. NO VERTICAL JOINTS ARE PERMITTED IN SIGN. NO HORIZONTAL JOINTS THROUGH SIGN LEGEND OR SYMBOLS ARE PERMITTED IN SIGN
10. REMOVE SIGN POSTS AND/OR POST STUBS IN THEIR ENTIRETY WHEN NO LONGER REQUIRED.
11. ALL LABOR, MATERIALS, AND EQUIPMENT, INCLUDING TEMPORARY SUPPORTS REQUIRED TO INSTALL, MAINTAIN, RELOCATE, AND/OR REMOVE THE TEMPORARY SIGN, INCLUDING SUPPORTS, ARE CONSIDERED TO BE INCLUDED IN THE COST OF THE TEMPORARY SIGN.
12. SAW CUTS IN WOOD POSTS ARE TO BE PARALLEL TO THE BOTTOM OF THE SIGN.
13. POSTS SHALL NOT EXTEND MORE THAN 4" ABOVE TOP OF SIGN.
14. TEMPORARY WOOD SUPPORTS DO NOT REQUIRE PRESERVATIVE TREATMENT.

NOT TO SCALE

| | | | | |
|--|-------------------|------------------------|-----------|-------------------|
| MICHIGAN DEPARTMENT OF TRANSPORTATION BUREAU OF FIELD SERVICES SPECIAL DETAIL | F.H.W.A. APPROVAL | 7/20/2016 PLAN DATE | WZD-100-A | SHEET 11 OF 11 |
|--|-------------------|------------------------|-----------|-------------------|

NOTE: THE ORIGINAL SIGNED COPY IS KEPT ON FILE AT THE MICHIGAN DEPARTMENT OF TRANSPORTATION.

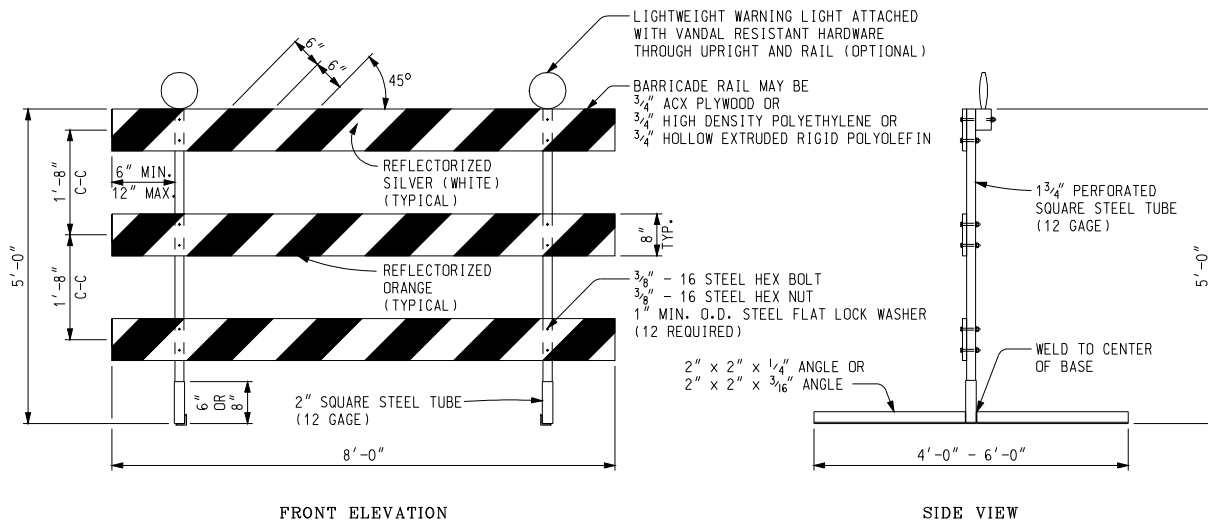

PERFORATED SQUARE STEEL TUBE OPTION

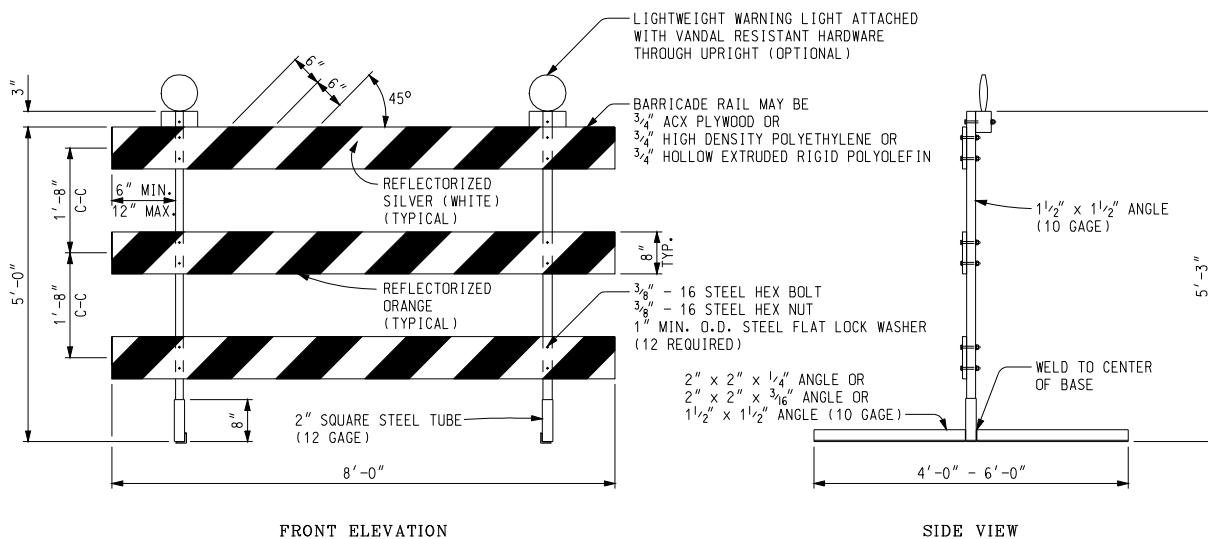

ANGLE IRON OPTION

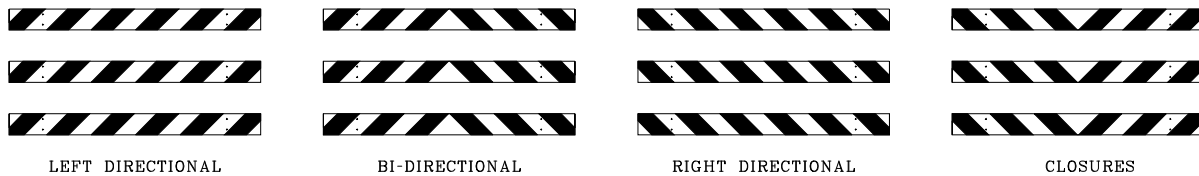

BARRICADE RAIL SHEETING OPTIONS
TYPE III BARRICADES

Other Type III Barricades meeting current NCHRP crash worthy criteria can be found on the FHWA Safety website at http://safety.fhwa.dot.gov/roadway_dept/road_hardware/wzd.htm

NOT TO SCALE

File: T&S/Typ/Signs/WorkZones/wzd 125 d

Rev. 09/22/09 PJ



PREPARED BY
TRAFFIC AND SAFETY

ENGINEER OF DELIVERY

ENGINEER OF DEVELOPMENT

(SPECIAL DETAIL)

FHWA APPROVAL DATE

MICHIGAN DEPARTMENT OF TRANSPORTATION
BUREAU OF HIGHWAYS DELIVERY STANDARD PLAN FOR

Temporary
Traffic Control Devices

9/22/09
PLAN DATE

WZD-125-E

SHEET
1 of 3

NOTE: THE ORIGINAL SIGNED COPY IS KEPT ON FILE AT THE MICHIGAN DEPARTMENT OF TRANSPORTATION.

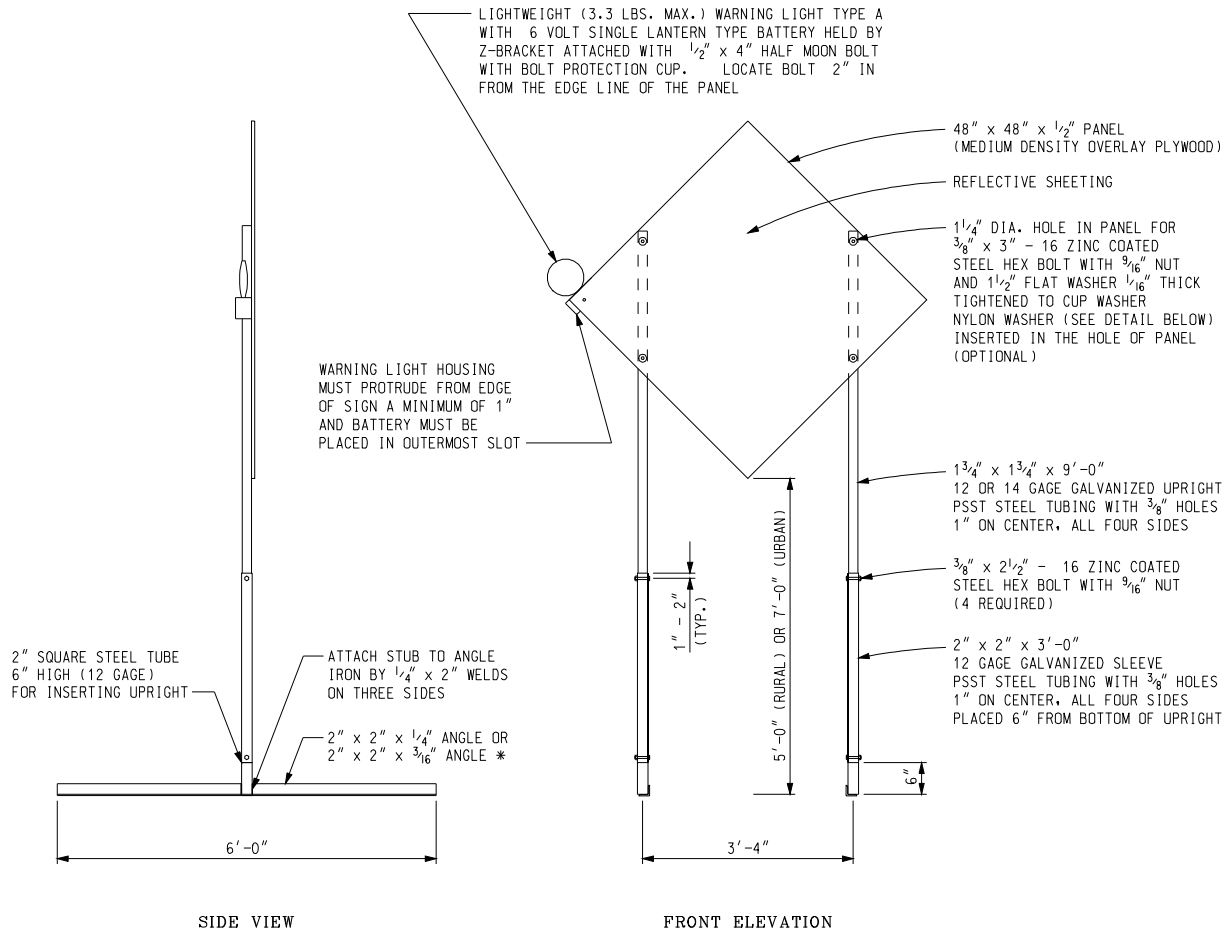

TEMPORARY SIGN SUPPORT

(WARNING LIGHT PLACED ON SIDE CLOSEST TO TRAFFIC)

- * SIGN STAND IS BALLASTED WITH FOUR OR MORE 35 LB SANDBAGS. A MINIMUM OF ONE ON EACH END.
- UPRIGHTS SHALL NOT EXTEND ABOVE THE SIGN PANEL.

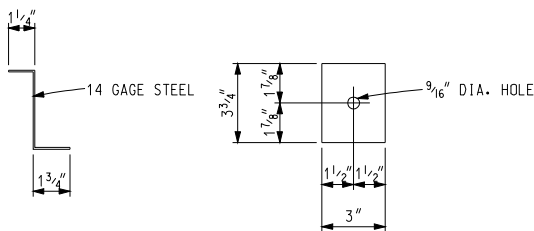

Z-BRACKET DETAIL

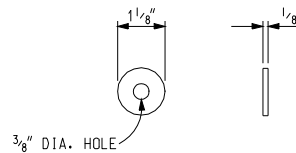

OPTIONAL NYLON WASHER

Other temporary sign supports meeting current NCHRP crash worthy criteria can be found on the FHWA Safety website at http://safety.fhwa.dot.gov/roadway_dept/road_hardware/wzd.htm

NOT TO SCALE

MICHIGAN DEPARTMENT OF TRANSPORTATION
BUREAU OF HIGHWAYS DELIVERY STANDARD PLAN

(SPECIAL DETAIL)
FHWA APPROVAL DATE

9/22/09
PLAN DATE

WZD-125-E

SHEET
2 of 3

NOTE: THE ORIGINAL SIGNED COPY IS KEPT ON FILE AT THE MICHIGAN DEPARTMENT OF TRANSPORTATION.

- PLASTIC DRUM
- ▲▲▲ PROPOSED TYPE III BARRICADE
- △△△ EXISTING TYPE III BARRICADE

SYMBOLS TO BE USED ON PLANS

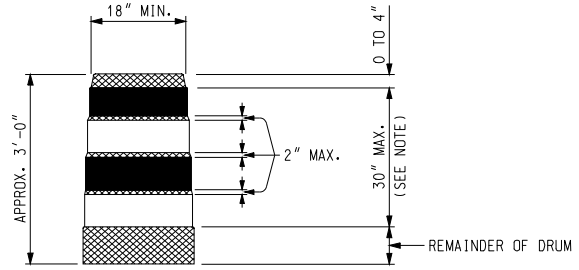

- REFLECTORIZED ORANGE
- REFLECTORIZED WHITE
- NON REFLECTORIZED ORANGE

NOTE:
 DRUMS SHALL HAVE AT LEAST 4 HORIZONTAL REFLECTORIZED STRIPES (2 ORANGE AND 2 WHITE) OF 6" UNIFORM WIDTH, ALTERNATING IN COLOR WITH THE TOPMOST REFLECTORIZED STRIPE BEING ORANGE. NON REFLECTORIZED SPACES BETWEEN THE HORIZONTAL REFLECTORIZED ORANGE AND WHITE STRIPES SHALL BE ORANGE IN COLOR AND EQUAL IN WIDTH.

PLASTIC DRUM

NOTES:

2" PERFORATED SQUARE STEEL TUBES MAY BE USED TO FABRICATE THE HORIZONTAL BASE OF THE TYPE III BARRICADE.

WARNING LIGHTS SHALL BE PLACED ACCORDING TO THE CURRENT STANDARD SPECIFICATIONS FOR CONSTRUCTION AND ALL OTHER PROVISIONS IN THE CONTRACT WHEN THEY ARE USED ON TYPE III BARRICADES.

SEE ROAD STANDARD PLANS R-113-SERIES FOR TEMPORARY CROSSTRAVERS FOR DIVIDED ROADWAY, AND R-126-SERIES FOR TYPICAL LOCATION AND SPACING OF PLASTIC DRUMS FOR PLACEMENT OF TEMPORARY CONCRETE BARRIER.

SIGNS, BARRICADES, AND PLASTIC DRUMS SHALL BE FACED WITH PRESSURE-SENSITIVE REFLECTIVE SHEETING ACCORDING TO THE CURRENT STANDARD SPECIFICATIONS FOR CONSTRUCTION.

SANDBAGS SHALL BE USED WHEN SUPPLEMENTAL WEIGHTS ARE REQUIRED TO ACHIEVE STABILITY OF THE BARRICADE. THE SANDBAGS SHALL BE PLACED SO THEY WILL NOT COVER OR OBSTRUCT ANY REFLECTIVE PORTION OF THE TRAFFIC CONTROL DEVICE.

NOT TO SCALE

| | | | | |
|--|--|-----------|-----------|-----------------|
| MICHIGAN DEPARTMENT OF TRANSPORTATION BUREAU OF HIGHWAYS DELIVERY STANDARD PLAN | (SPECIAL DETAIL) FHWA APPROVAL DATE | 9/22/09 | WZD-125-E | SHEET 3 of 3 |
| File: T&S/Typ/Signs/WorkZones/wzd 125 d | Rev. 09/22/09 PJ | PLAN DATE | | |

NOTE: THE ORIGINAL SIGNED COPY IS KEPT ON FILE AT THE MICHIGAN DEPARTMENT OF TRANSPORTATION.

CITY OF ANN ARBOR
DETAILED SPECIFICATION
FOR
MINOR TRAFFIC CONTROL

AA:DAD

1 of 4

04/17/18

a. Description. This work shall consist of protecting and maintaining vehicular and pedestrian traffic, in accordance with the sections 104.11 and 812 of the of the Michigan Department of Transportation (MDOT) 2012 Standard Specifications for Construction; Part 6 of the 2011 Edition of the Michigan Manual of Uniform Traffic Control Devices (MMUTCD); as directed by the Engineer, and as described herein.

The work shall include, but is not limited to the following:

- The furnishing and operating of miscellaneous signs, warning devices, flags, and cones;
- The operation of additional signs furnished by the City;
- Furnishing and installing meter bags;
- Coordinating with Republic Parking System to have meter bags installed and removed;
- Maintaining pedestrian traffic;
- Temporarily covering/uncovering traffic controls as directed;
- Temporarily covering/uncovering existing signs as directed;
- Any/all other miscellaneous and/or incidental items that are necessary to perform the work properly.

b. Materials. Materials and equipment shall meet the requirements specified in section 812 of the MDOT 2012 Standard Specifications for Construction.

c. Construction. The Contractor shall perform the work required by this detailed specification throughout the life of the Contract.

The Contractor shall maintain pedestrian traffic at all times. For maintaining normal pedestrian traffic while performing sidewalk and driveway repair place, Pedestrian Type II Baricade, Temp, Pedestrian Type II Channelizer, Temp, "Sidewalk Closed" and/or "Cross Here" signs at locations directed by the Engineer.

All temporary traffic/pedestrian control devices furnished by the Contractor shall remain the property of the Contractor. The City is not responsible for stolen or damaged signs, barricades, barricade lights or other traffic maintenance items. The Contractor shall replace missing or damaged traffic control devices immediately. All existing signs, and signs erected by the City of Ann Arbor on this project shall be preserved, protected, and maintained by the Contractor. At the direction of the Engineer, City forces will repair or replace any existing City owned signs damaged by the Contractor during the work.

The Contractor shall temporarily cover conflicting traffic and/or parking signs when directed by the Engineer.

The City will enforce parking violation citations issued to the Contractor, subcontractor, and material suppliers including each of their respective employees under appropriate City Code.

Where there is metered parking within the influence of project work, the Contractor shall coordinate with Republic Parking System to have meter bags temporarily installed and removed when the work is complete.

The Contractor shall maintain vehicular and pedestrian traffic during the work by the use of traffic regulators, channelizing devices and signs as necessary, and as directed by the Engineer, and in accordance with 2011 Edition of the MMUTCD. Typical applications for maintaining pedestrian traffic in accordance with the 2011 Edition of the MMUTCD are included in this detailed specification.

In order to maintain areas of on street parking available for residents, the Engineer may direct the contractor to cover and uncover temporary "No Parking" signs within the project limits multiple times throughout the course of the project.

d. Measurement and Payment. Measure and pay for the completed work, as described, at the contract unit price using the following pay item:

| <u>Pay Item</u> | <u>Pay Unit</u> |
|---|-----------------|
| Minor Traffic Control, Max \$____ | Lump Sum |

Measure **Minor Traffic Control, Max \$____** by the unit lump sum and pay for it at the contract unit price, which price includes costs for all labor, equipment and materials necessary to complete the work. The contract unit price also includes payment for any/all costs related to any temporary traffic control devices directed for use by the Engineer where there is no specific pay item in the Contract, for repeated covering and uncovering of signs, and maintaining pedestrian traffic.

Include any/all costs for transporting temporary traffic control devices required by this detailed specification or where there is no separate pay item in the contract unit price for **Minor Traffic Control, Max \$____**.

The Contractor is solely responsible for any/all repair or replacement costs associated with damage to existing City signs caused by its construction activities and/or operations.

Measurement will be on a pro rata basis at the time of each progress payment, and based on the ratio of work completed during the payment period and the total contract amount. When all of the work of this Contract is complete, the measurement of this item shall be 1.0 Lump Sum, less any deductions incurred for inadequate performance as described herein. This amount will not increase for any reason, including extensions of time, extras, and/or additional work.



Figure 6H-28. Sidewalk Detour or Diversion (TA-28)

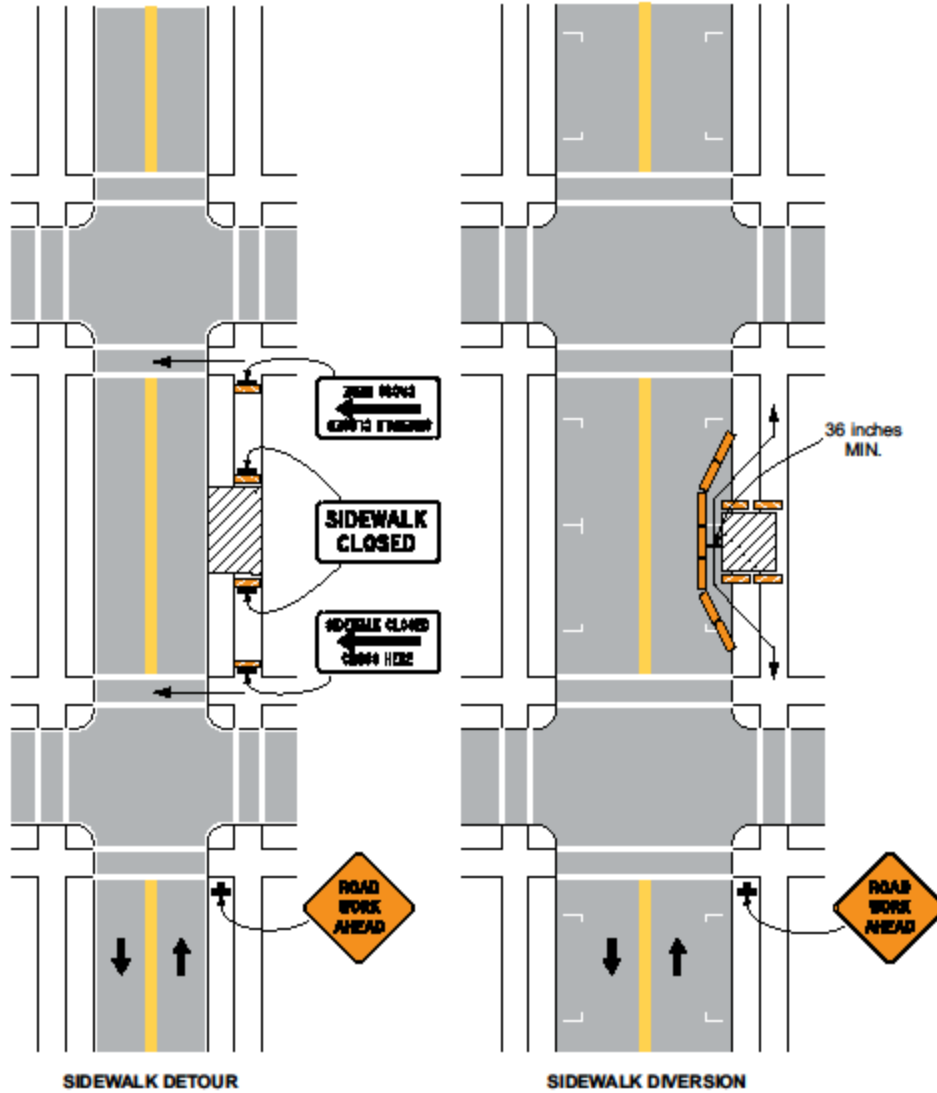

Typical Application 28

Note: See Tables 6H-2 and 6H-3 for the meaning of the symbols and/or letter codes used in this figure.

Figure 6H-29. Crosswalk Closures and Pedestrian Detours (TA-29)

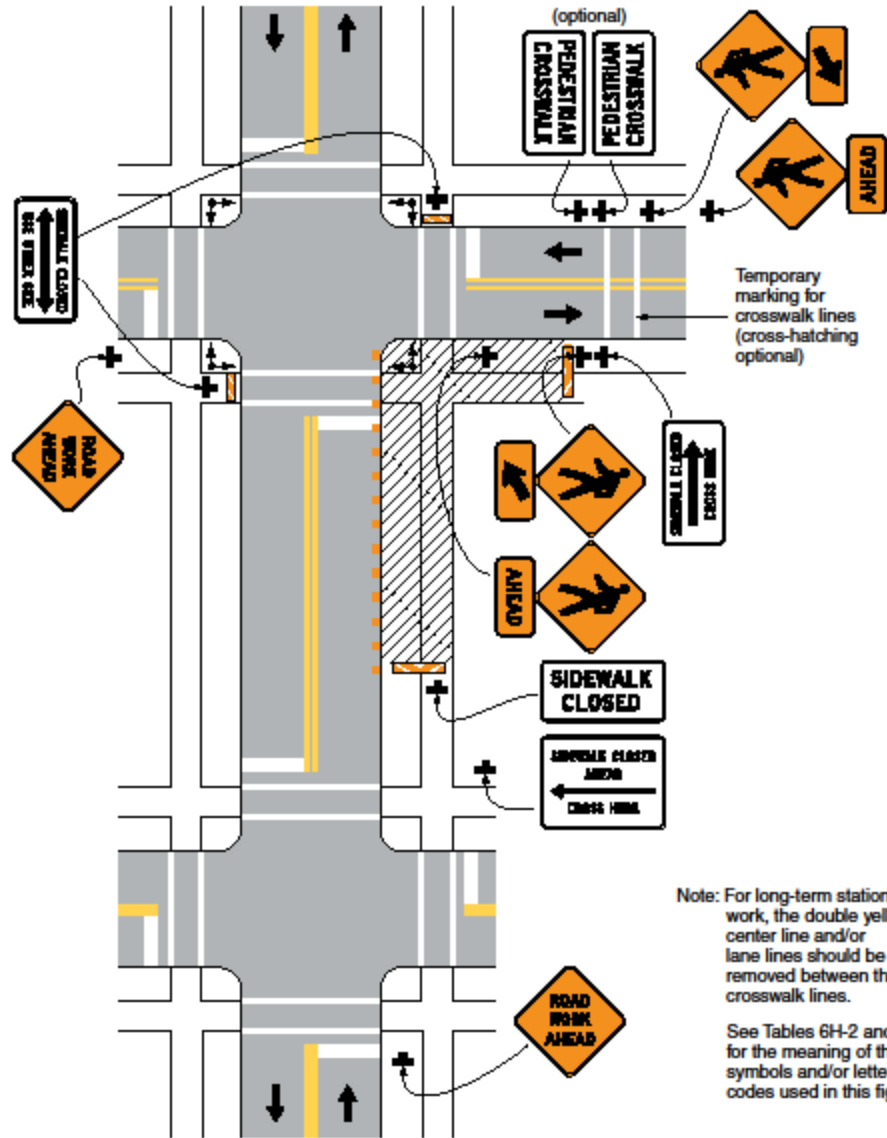

Typical Application 29

CITY OF ANN ARBOR
DETAILED SPECIFICATION
FOR
NO PARKING SIGNS

AA:DAD

1 of 1

04/17/18

a. Description. This work shall consist of installing, maintaining and removing of "No Parking" signs and posts as outlined herein and as referenced on the plans. Install "No Parking" signs in accordance with the section 812 of the Michigan Department of Transportation (MDOT) 2012 Standard Specifications for Construction Standard Specifications and the 2011 Michigan Manual of Uniform Traffic Control Devices (MMUTCD).

b. Materials. The City will furnish "No Parking" signs to the Contractor at no cost. The Contractor shall furnish the sign support and mounting hardware materials, which materials shall be in accordance with those specified in section 919 of the MDOT 2012 Standard Specifications for Construction.

c. Construction. Prior to the commencement of any construction activity, the Contractor shall place "No Parking" signs as directed by the Engineer. The Contractor shall obtain a permit for "Temporary Permission of Reserve Parking Lane for Work Related Purposes" from the City's Project Management Services Unit. Obtain this permit a minimum of five (5) business days prior to the posting of "No Parking" signs.

The Contractor shall securely bolt the signs to the sign supports as directed by the Engineer. The Contractor shall imbed all sign supports at least two feet into the ground, and ensure that installations are stable and safe. There shall be a minimum of six feet and maximum of seven feet of clearance maintained between the bottom of the installed sign and the ground. Place signs at intervals no greater than 75 feet, and as necessary to eliminate parking in the construction area.

The installation of "No Parking" signs shall be in accordance with the permit. Install "No Parking" signs as directed by the Engineer, and at least 48 hours prior to the proposed start-of-work/enforcement date. Cover "No Parking" signs to allow for on-street parking until 48 to 24 hours prior to the start of the work. Cover "No Parking" signs during non-working periods longer than 72 hours. Return "No Parking" signs to the City upon the completion of work.

d. Measurement and Payment. Measure and pay for the completed work, as described, at the contract unit price using the following pay item:

| <u>Pay Item</u> | <u>Pay Unit</u> |
|-----------------------|-----------------|
| No Parking Sign | Each |

Measure **No Parking Sign** individually in place by the unit each and pay for it at the contract unit price, which price includes all cost for labor, equipment and materials necessary to complete the work. Measurement will be for the maximum number of signs installed on a project location at any one time. The unit price also includes the removal and return of "No Parking" signs to the City upon completion of the project.

The City will back charge the Contractor for replacement costs associated with damaged or unreturned signs.

APPENDIX

- Notices to Bidders
- Michigan Department of Transportation (MDOT)
Special Provisions
 - MDOT Supplemental Specifications
 - Project Listing of Streets
 - Project Log
 - Project Location Maps

CITY OF ANN ARBOR

NOTICE TO BIDDERS

PROJECT COORDINATION

AA:DAD

1 of 1

04/17/18

The City of Ann Arbor hereby notifies the Contractor there are construction projects directly adjacent to the Construction Influence Area (C.I.A.), or within the local vicinity, that may affect the various work activities, maintenance of traffic, and/or trucking operations involved with this project's various locations. The projects are as follows, and the City anticipates construction of them during the same timeframe as this project.

- Green Road Sidewalk Gap Project between Burbank Drive and Gettysburg Road/Burbank Drive
- Pauline Boulevard Water Main Replacement Project between South Seventh Street and West Stadium Boulevard
- Scio Church Road Resurfacing Project between South Seventh Street and South Main Street
- Seventh Street Preventative Maintenance and Pavement Marking Improvements Project between Scio Church Road and Miller Avenue

The above is not necessarily be a complete listing of all area projects that could potentially impact this one. Prior to commencing with any construction, the Contractor shall verify with the City the presence of any other concurrent public or permitted projects within the vicinity.

The Contractor shall coordinate its work on this project with that by Contractor(s) on all other projects within the local vicinity, as directed by the Engineer. The Engineer will make no additional compensation or adjustments to contract unit prices for costs incurred by the Contractor due to coordinating with or delays caused by other projects.

CITY OF ANN ARBOR

NOTICE TO BIDDERS

UTILITY COORDINATION

AA:DAD

1 of 1

04/17/18

The contractor shall cooperate and coordinate construction activities with the owners of utilities as stated in Section 104.08 of the 2012 Michigan Department of Transportation (MDOT) Standard Specifications for Construction. In addition, for the protection of underground utilities, the contractor shall follow the requirements in Section 107.12 of the 2012 MDOT Standard Specifications for Construction. Contractor delay claims, resulting from a utility, will be determined based upon Section 109.05.E of the 2012 MDOT Standard Specifications for Construction.

For protection of underground utilities and in conformance with Public Act 174 of 2013, the contractor shall dial 800-482-7171 or 811 a minimum of three (3) full working days, excluding Saturdays, Sundays, and holidays prior to beginning construction in areas where utilities have not been previously located. The "Miss Dig" alert system will then routinely notify members to locate and mark their facilities. This, however, does not relieve the contractor of the responsibility of notifying utility owners that may not be a part of the system.

There will be no requirement for owners of public or private utilities to move their facilities on or from within the street right-of-way if those facilities will not interfere with the proposed project work and they do not present a hazard to the public or an extraordinary hazard to the Contractor's operations.

The City will not require utilities owners to move additional poles or structures in order to facilitate the operation of construction equipment unless the Engineer determines that such poles or structures constitute a hazard to the public or are dangerous to the Contractor's operations.

Private utility owners will complete any/all necessary relocations prior to construction.

The following is a list of Private and Public Utilities that may or may not have facilities located within the Right-of-Way. This list is for informational purposes only and is not an exhaustive list of utilities located within the Right-of-Way.

ATT – Telecommunications/Fiber Optic
550 South Maple Road
Ann Arbor, MI 48103
Contact: Andrew Johnson 734-996-2135

City of Ann Arbor – Water, Storm, Sanitary,
Telecommunications/Fiber Optic
W.R. Wheeler Service Center
4251 Stone School Road
Ann Arbor, MI 48108 734 794-6351

Comcast – Telecommunications/Fiber Optic
27800 Franklin Road
Southfield, MI 48034
Contact: Ron Sutherland 313-999-8300

DTE Energy – Electric & Street Lighting
8001 Haggerty Road
Belleville, MI 48111
Contact (Electric): Clay Combee 734-397-4112
Contact (Lighting): Brandon Faron 734-397-4017

DTE Energy – Gas
3150 E. Michigan Ave
Ypsilanti Township, MI 48198
Contact: Robert Czapiewski 734-544-7818

MCI – Telecommunications/Fiber Optic
2800 North Glenfille Road
Richardson, TX 75082
Contact: Dean Boyers 972-729-6016

MICHIGAN
DEPARTMENT OF TRANSPORTATION

SPECIAL PROVISION
FOR
PROGRESS SCHEDULE

CFS:JJG

1 of 1

APPR:MB:LFS:01-09-18
FHWA:APPR:03-01-18

Delete the definition for Progress Schedule in subsection 101.03, on page 12 of the Standard Specifications for Construction, in its entirety and replace with the following:

Progress Schedule. A sequential listing of all the controlling operations and the estimated time the operations will remain controlling. The progress schedule is submitted by the Contractor after award and prior to starting work and is reviewed and approved by the Department. When approved, the progress schedule, or updated progress schedule, will become part of the contract.

Delete subsection 102.14, on page 22 of the Standard Specifications for Construction, in its entirety.

Delete the first sentence in the second paragraph of subsection 108.05, on page 74 of the Standard Specifications for Construction, in its entirety and replace with the following.

Submit a critical path method (CPM) schedule if required in the contract documents. Submittal of a progress schedule will not be required as the CPM schedule will replace the progress schedule.

Add the following paragraphs directly below the first paragraph of subsection 108.05.A.1, on page 74 of the Standard Specifications for Construction.

The progress schedule is to be submitted by the Contractor to the Engineer within 7 calendar days of award and prior to starting work.

The Engineer will provide documented approval, comments, or rejection within 7 calendar days of receipt of the Contractor's submittal, resubmittal, or responses.

The Contractor must resolve all responses within 7 calendar days of receipt of any Engineer requests or rejections.

If the progress schedule is not approved within 30 calendar days of contract award, the Engineer may withhold all or part of contract payments until the progress schedule is approved.

Delete the last sentence in the first paragraph of subsection 108.05.A.2, on page 74 of the Standard Specifications for Construction in its entirety.

MICHIGAN
DEPARTMENT OF TRANSPORTATION

SPECIAL PROVISION
FOR
DEBRIS OR MATERIALS IN TRAFFIC LANES

CFS:BRZ

1 of 1

APPR:EMB:DAJ:01-10-08
FHWA:APPR:06-01-11

Delete Subsection 104.07.B.2 on page 36 of the Standard Specifications for Construction, in its entirety and replace it with the following:

- 2. Construction Safety Program.** Before beginning work on the project, the Contractor must submit a written "Construction Safety Program" that outlines the plan and procedures for preventing and mitigating accidents and fires on the project and meeting all health and safety requirements of the contract. Also in the program include provisions for meeting the requirements of subsection 812.03 and details for the materials and equipment that will be used to prevent construction related debris or materials from entering the open lanes of traffic and what actions, including traffic control measures, will be taken to immediately and safely remove the debris or material from the roadway. The Contractor must meet with the Engineer to discuss the "Construction Safety Program" and to develop mutual understandings to govern the administration and enforcement of the program.

Replace the second sentence in the first paragraph of Subsection 104.07.C.3 on page 37 of the Standard Specifications for Construction with the following:

The Contractor is responsible, at the Contractor's expense, to provide the necessary materials and equipment to prevent construction related debris or materials from entering the open lanes of traffic. This includes protection of traffic controls, removal of spilled materials or debris from the roadbed or drainage courses, and repair of damaged facilities necessary for public travel and safety.

MICHIGAN
DEPARTMENT OF TRANSPORTATION

SPECIAL PROVISION
FOR
HIGH VISIBILITY CLOTHING

SSA:JDG

1 of 1

APPR:MWB:CRB:06-18-14
FHWA:APPR:06-27-14

Add the following, to the end, of subsection 104.07.B, Safety and Health Requirements, on page 36 of the Standard Specification for Construction:

4. **Worker Visibility.** Effective November 24, 2008, all workers within the right-of-way who are exposed to traffic or to construction equipment within the work area, must wear high visibility clothing.

High visibility clothing or high visibility safety apparel is personal protective safety clothing that is intended to provide conspicuity during both daytime and nighttime usage. High Visibility safety apparel must meet the Performance Class 2 or 3 requirements of the American National Standards Institute/International Safety Equipment Association (ANSI/ISEA) 107-2004 for High-Visibility Safety Apparel and subsequent revisions thereof.

Costs incurred to comply with this requirement will be the responsibility of the Contractor.

MICHIGAN
DEPARTMENT OF TRANSPORTATION

SPECIAL PROVISION
FOR
CONSTRUCTION STAGING AREAS

DES:LFS

1 of 1

APPR:JJG:KAS:10-06-11
FHWA:APPR:10-11-11

Add the following subsection to section 107, on page 70 of the 2012 Standard Specifications for Construction:

107.22 Construction Staging Areas. The contractor must not use any public recreation area as a staging area, marshalling yard, storage facility, or for any other construction support unless it is defined in the contract.

Public recreation areas include: parks, trails, game areas, wildlife and waterfowl refuges, playgrounds, golf courses, athletic fields or similar areas which are publically owned by public school districts, local, state, or federal governments.

Any agreements negotiated between the Contractor and the owner of the public recreation area, before or after the award of the contract will not be considered valid by the Department.

If the Engineer determines the Contractor is in non-compliance with this subsection, penalties up to and including termination of the contract, in accordance with subsection 108.12, may be enacted as well as the immediate restoration of the public recreation area at the Contractor's cost.

MICHIGAN
DEPARTMENT OF TRANSPORTATION

SPECIAL PROVISION
FOR
OPEN TO TRAFFIC

CFS:JJG

1 of 1

APPR:MB:DBP:07-07-17
FHWA:APPR:07-10-17

Delete subsection 107.21, on page 69 of the Standard Specifications for Construction, in its entirety and replace with the following:

107.21. Open to Traffic. The Contractor must not open the project or sections thereof to traffic until approved by the Engineer. Whenever the project or section thereof is in a condition suitable for traffic, the Engineer will determine if it is approved for traffic before project completion and the Contractor must open the project or section thereof to traffic as directed by the Engineer. To determine whether the project or section thereof is approved for traffic, the Engineer will verify that the surfacing material, shoulders, guardrails, signs, and other appurtenances are completed as required by the contract. The Engineer's approval of the project or section thereof for traffic does not constitute partial or final acceptance of the project or any part of it, or a waiver of any provision of the contract. The Contractor is not responsible for the costs of maintaining the section of the project opened for traffic.

If the Engineer approves the entire project or any section of it for traffic and the Contractor opens it to traffic before final acceptance and final payment, the Contractor must perform the remainder of the work in a manner that causes the least obstruction to traffic. The Contractor must make provisions for the safety of traffic as required by the contract. Legal weight restrictions, established by 1949 PA 300 as amended, local ordinances, or legal posting, apply to sections of the project opened to traffic.

Before the seasonal suspension, the Engineer will determine the work the Contractor must complete to bring the project to an acceptable condition for traffic and winter maintenance, including necessary traffic and erosion control measures. Until the Contractor completes this work, the Engineer will not designate the project as approved for traffic. On sections of the project opened to traffic, the Contractor must correct damage due to defective materials, to faulty workmanship, to operations of the Contractor, and to natural causes (except as provided in subsection 107.11 of the Standard Specifications for Construction), at no additional cost to the Department.

MICHIGAN
DEPARTMENT OF TRANSPORTATION

SPECIAL PROVISION
FOR
SCHEDULE OF LIQUIDATED DAMAGES FOR OVERSIGHT

CFS:BED

1 of 1

APPR:MB:JJG: 07-15-16

FHWA:APPR:07-29-16

Delete Table 108-1 in subsection 108.10.C.1, on page 83 of the Standard Specifications for Construction, in its entirety and replace with the following.

| Table 108-1 | | |
|---|-----------------------------|------------------------------------|
| Schedule of Liquidated Damages for Oversight | | |
| Original Contract Amount | | Amount per Calendar Day, \$ |
| From more than, \$ | To and including, \$ | |
| 0 | 100,000 | 400 |
| 100,000 | 500,000 | 700 |
| 500,000 | 1,000,000 | 950 |
| 1,000,000 | 5,000,000 | 1,350 |
| 5,000,000 | 15,000,000 | 2,300 |
| Over 15,000,000 | | 3,900 |

MICHIGAN
DEPARTMENT OF TRANSPORTATION

SPECIAL PROVISION
FOR
FORCE ACCOUNT BUSINESS TAXES

CFS:RJC

1 of 1

APPR:JJG:JDM:04-14-15
FHWA:APPR:04-17-15

Delete subsection 109.05.D.8, on page 101 of the 2012 Standard Specifications for Construction in its entirety.

MICHIGAN
DEPARTMENT OF TRANSPORTATION

SPECIAL PROVISION
FOR
**FORCE ACCOUNT MARK-UP FOR BOND PREMIUM, INSURANCE AND PAYROLL
TAXES**

CFS:JJG

1 of 1

APPR:LFS:MB:08-12-16

FHWA:APPR:08-18-16

Delete subsection 109.05.D.4, on page 97 of the Standard Specifications for Construction, in its entirety.

Delete the first paragraph of subsection 109.05.D.3, on page 96 of the Standard Specifications for Construction, in its entirety and replace with the following:

- 3. Labor.** The Engineer will pay the Contractor an amount equal to the sum of the following labor costs, plus 55 percent of the sum (for road work) or 60 percent of the sum (for bridge work) to cover the costs of field and home office overhead, bond premium, insurance, payroll taxes and to provide for a reasonable profit.

MICHIGAN
DEPARTMENT OF TRANSPORTATION

SPECIAL PROVISION
FOR
DELAY COSTS

CFS:JJG

1 of 1

APPR:RJC:MB:02-22-17
FHWA:APPR:02-27-17

Delete subsections 109.05.E.1.a through 109.05.E.1.e, on page 102 of the Standard Specifications for Construction, in their entirety and replace with the following:

- a. Proof of cost of project staff salaries, wages, payroll taxes and insurance.
- b. Proof of escalated cost for labor, equipment, and material.
- c. Proof of material storage costs.

MICHIGAN
DEPARTMENT OF TRANSPORTATION

SPECIAL PROVISION
FOR
SAMPLING ASPHALT BINDER ON LOCAL AGENCY PROJECTS

CFS:MF

1 of 1

APPR:JAR:JTL:12-19-01
FHWA:CON. APPR:06-06-11

For informational purposes, original samples of asphalt binder will be taken by the Contractor and delivered to the Engineer prior to incorporation into the mixture. The frequency of sampling will be determined by the Engineer. The cost of obtaining and delivering the samples to the Engineer will be included in the hot mix asphalt (HMA) pay items.

The Contractor must certify in writing that the materials used in the HMA mixture are from the same source as the materials used in developing the HMA mixture design and the bond coat is from an approved supplier as stated in the *Material Quality Assurance Procedures Manual*.

MICHIGAN
DEPARTMENT OF TRANSPORTATION

SPECIAL PROVISION
FOR
RECYCLED HOT MIX ASPHALT MIXTURE ON LOCAL AGENCY PROJECTS

CFS:KPK

1 of 2

APPR:JWB:CJB:03-13-14
FHWA:APPR:03-13-14

Add the following subsection to subsection 501.02.A.2, on page 234 of the Standard Specifications for Construction.

- c. **Reclaimed Asphalt Pavement (RAP) and Binder Grade Selection.** The method for determining the binder grade in HMA mixtures incorporating RAP is divided into three categories designated Tier 1, Tier 2 and Tier 3. Each tier has a range of percentages that represent the contribution of the RAP binder toward the total binder, by weight. The tiers identified below apply to HMA mixtures with the following exception: Superpave mixture types E3, E3 High Stress, E10, E10 High Stress, E30, E30 High Stress, E50, and E50 High Stress used as leveling or top course must be limited to a maximum of 27 percent RAP binder by weight of the total binder in the mixture.

Recycled materials may be used as a substitute for a portion of the new materials required to produce HMA mixtures in accordance with contract.

- **Tier 1 (0% to 17% RAP binder by weight of the total binder in the mixture).** No binder grade adjustment is made to compensate for the stiffness of the asphalt binder in RAP.
- **Tier 2 (18% to 27% RAP binder by weight of the total binder in the mixture).** For all mixtures no binder grade change will occur in Tier 2 for all shoulder and temporary road mixtures.

The required asphalt binder grade must be at least one grade lower for the low temperature than the design binder grade required for the specified project mixture type. Lowering the high temperature of the binder one grade is optional. For example, if the design binder grade for the mixture type is PG 58-22, the required grade for the binder in the HMA mixture containing RAP would be a PG 52-28 or a PG 58-28.

For Marshall Mixes, no binder grade change will be required when Average Daily Traffic (ADT) is above 7000 or Commercial Average Daily Traffic (CADT) is above 700. No binder grade change will occur for LVSP, E03 and E1 mixtures used as leveling or top course.

The asphalt binder grade can also be selected using a blending chart for high and low temperatures. Supply the blending chart and the RAP test data used in determining the binder selection according to *AASHTO M 323*.

- **Tier 3 (\geq 28% RAP binder by weight of the total binder in the mixture).** The binder

grade for the asphalt binder is selected using a blending chart for high and low temperatures per *AASHTO M 323*. Supply the blending chart and the RAP test data used in determining the binder selection.

MICHIGAN
DEPARTMENT OF TRANSPORTATION

SPECIAL PROVISION
FOR
ACCEPTANCE OF HOT MIX ASPHALT MIXTURE ON LOCAL AGENCY PROJECTS

CFS:KPK

1 of 7

APPR:CJB:JWB:07-05-16

FHWA:APPR:07-05-16

a. Description. This special provision provides sampling and testing requirements for local agency projects using the roller method and the nuclear density gauge testing. Provide the hot mix asphalt (HMA) mixture in accordance with the requirements of the standard specifications, except where modified herein.

b. Materials. Provide aggregates, mineral filler (if required), and asphalt binder to produce a mixture proportioned within the master gradation limits shown in the contract, and meeting the uniformity tolerance limits in Table 1.

Table 1: Uniformity Tolerance Limits for HMA Mixtures

| Parameter | | Top and Leveling Course | | Base Course | | |
|---|------------------------------|-------------------------|-----------|----------------|-----------|------|
| Number | Description | Range 1 (a) | Range 2 | Range 1 (a) | Range 2 | |
| 1 | % Binder Content | -0.30 to +0.40 | ±0.50 | -0.30 to +0.40 | ±0.50 | |
| 2 | % Passing | # 8 and Larger Sieves | ±5.0 | ±8.0 | ±7.0 | ±9.0 |
| | | # 30 Sieve | ±4.0 | ±6.0 | ±6.0 | ±9.0 |
| | | # 200 Sieve | ±1.0 | ±2.0 | ±2.0 | ±3.0 |
| 3 | Crushed Particle Content (b) | Below 10% | Below 15% | Below 10% | Below 15% | |
| a. This range allows for normal mixture and testing variations. The mixture must be proportioned to test as closely as possible to the Job-Mix-Formula (JMF). b. Deviation from JMF. | | | | | | |

Parameter number 2 as shown in Table 1 is aggregate gradation. Each sieve will be evaluated on one of the three gradation tolerance categories. If more than one sieve is exceeding Range 1 or Range 2 tolerances, only the one with the largest exceedance will be counted as the gradation parameter.

The master gradation should be maintained throughout production; however, price adjustments will be based on Table 1. Aggregates which are to be used in plant-mixed HMA mixtures must not contain topsoil, clay, or loam.

c. Construction. Submit a Mix Design and a JMF to the Engineer. Do not begin production and placement of the HMA until receipt of the Engineer's approval of the JMF. Maintain the binder content, aggregate gradation, and the crushed particle content of the HMA mixture within the Range 1 uniformity tolerance limits in Table 1. For mixtures meeting the definition of top or leveling course, field regress air void content to 3.5 percent with liquid asphalt cement unless

specified otherwise on HMA application estimate. For mixtures meeting the definition of base course, field regress air void content to 3.0 percent with liquid asphalt cement unless specified otherwise on HMA application estimate.

Ensure all persons performing Quality Control (QC) and Quality Assurance (QA) HMA field sampling are "Local Agency HMA Sampling Qualified" samplers. At the Pre-Production or Pre-Construction meeting, the Engineer will determine the method of sampling to be used. Ensure all sampling is done in accordance with *MTM 313 (Sampling HMA Paving Mixtures)* or *MTM 324 (Sampling HMA Paving Mixtures Behind the Paver)*. Samples are to be taken from separate hauling loads.

For production/mainline type paving, obtain a minimum of two samples, each being 20,000 grams, each day of production, for each mix type. The Engineer will sample and maintain possession of the sample. Sampling from the paver hopper is prohibited. Each sample will be divided into two 10,000 gram parts with one part being for initial testing and the other part being held for possible dispute resolution testing. Obtain a minimum of three samples for each mix type regardless of the number of days of production.

Obtain samples that are representative of the day's paving. Sample collection is to be spaced throughout the planned tonnage. One sample will be obtained in the first half of the tonnage and the second sample will be obtained in the second half of the tonnage. If planned paving is reduced or suspended, when paving resumes, the remaining sampling must be representative of the original intended sampling timing.

Ensure all persons performing testing are Bit Level One certified or Bit QA/QC Technician certified.

Ensure daily test samples are obtained, except, if the first test results show that the HMA mixture is in specification, the Engineer has the option of not testing additional samples from that day.

At the Pre-Production or Pre-Construction meeting, the Engineer and Contractor will collectively determine the test method for measuring asphalt content (AC) using *MTM 319 (Determination of Asphalt Content from Asphalt Paving Mixtures by the Ignition Method)* or *MTM 325 (Quantitative Extraction of Bitumen from HMA Paving Mixtures)*. Back calculation will not be allowed for determining asphalt content.

Ensure all labs performing local agency acceptance testing are qualified labs per the *HMA Production Manual* and participate in the MDOT round robin process, or they must be *AASHTO Materials Reference Laboratory (AMRL)* accredited for *AASHTO T 30* or *T 27*, and *AASHTO T 164* or *T 308*. Ensure on non-National Highway System (NHS) routes, Contractor labs are made available, and may be used, but they must be qualified labs as previously stated. Contractor labs may not be used on NHS routes. Material acceptance testing will be completed by the Engineer within 14 calendar days, except holidays and Sundays, for projects with less than 5,000 tons (plan quantity) of HMA and within 7 calendars days, except holidays and Sundays, for projects with 5,000 tons (plan quantity) or more of HMA, after the Engineer has obtained the samples. QA test results will be provided to the Contractor after the Engineer receives the QC test results. Failure on the part of the Engineer or the laboratory to provide Quality Assurance test results within the specified time frame does not relieve the Contractor of their responsibility to provide an asphalt mix within specifications.

The correlation procedure for ignition oven will be established as follows. Asphalt binder content based on ignition method from MTM 319. Gradation (*ASTM D 5444*) and Crushed particle content (*MTM 117*) based on aggregate from *MTM 319*. The incineration temperature will be established at the Pre-Production Meeting. The Contractor will provide a laboratory mixture sample to the acceptance laboratory to establish the correction factor for each mix. Ensure this sample is provided to the Engineer a minimum of 14 calendar days prior to production.

For production/mainline type paving, the mixture may be accepted by visual inspection up to a quantity of 500 tons per mixture type, per project (not per day). For non-production type paving defined as driveways, approaches, and patching, visual inspection may be allowed regardless of the tonnage.

The mixture will be considered out-of-specification, as determined by the acceptance tests, if for any one mixture, two consecutive tests per parameter, (for Parameter 2, two consecutive aggregate gradations on one sieve) are outside Range 1 or Range 2 tolerance limits. If a parameter is outside of Range 1 tolerance limits and the second consecutive test shows that the parameter is outside of Range 2, then it will be considered to be a Range 1 out-of-specification. Consecutive refers to the production order and not necessarily the testing order. Out-of-specification mixtures are subject to a price adjustment per the Measurement and Payment section of this special provision.

Contractor operations will be suspended when the mixture is determined to be out-of-specification, but contract time will continue to run. The Engineer may issue a Notice of Non-Compliance with Contract Requirements (Form 1165), if the Contractor has not suspended operations and taken corrective action. Submit a revised JMF or proposed alterations to the plant and/or materials to achieve the JMF to the Engineer. Effects on the Aggregate Wear Index (AWI) and mix design properties will be taken into consideration. Production and placement cannot resume until receipt of the Engineer's approval to proceed.

Pavement in-place density will be measured using one of two approved methods. The method used for measuring in-place density will be agreed upon at a pre-production or pre-construction meeting.

Pavement in-place density tests will be completed by the Engineer during paving operations and prior to traffic staging changes. Pavement in-place density acceptance testing will be completed by the Engineer prior to paving of subsequent lifts and being open to traffic.

Option 1 – Direct Density Method

Use of a nuclear density gauge requires measuring the pavement density using the Gmm from the JMF for the density control target. The required in-place density of the HMA mixture must be 92.0 to 98.0 percent of the density control target. Nuclear density testing and frequency will be in accordance with the *MDOT Density Testing and Inspection Manual*.

Option 2 – Roller Method

The Engineer may use the Roller Method with a nuclear or non-nuclear density gauge to document achieving optimal density as discussed below.

Use of the density gauge requires establishing a rolling pattern that will achieve the required in-place density. The Engineer will measure pavement density with a density gauge using the Gmm from the JMF for the density control target.

Use of the Roller Method requires developing and establishing density frequency curves, and meeting the requirements of Table 2. A density frequency curve is defined as the measurement and documentation of each pass of the finished roller until the in-place density results indicate a decrease in value. The previous recording will be deemed the optimal density. The Contractor is responsible for establishing and documenting an initial or QC rolling pattern that achieves the optimal in-place density. When the density frequency curve is used, the Engineer will run and document the density frequency curve for each half day of production to determine the number of passes to achieve the maximum density. Table 5, located at the end of this special provision, can be used as an aid in developing the density frequency curve. The Engineer will perform density tests using an approved nuclear or non-nuclear gauge per the manufacturer's recommended procedures.

Table 2: Minimum Number of Rollers Recommended Based on Placement Rate

| Average Laydown Rate, Square Yards per Hour | Number of Rollers Required (a) | |
|--|--------------------------------|--------|
| | Compaction | Finish |
| Less than 600 | 1 | 1 (b) |
| 601 - 1200 | 1 | 1 |
| 1201 - 2400 | 2 | 1 |
| 2401 - 3600 | 3 | 1 |
| 3601 and More | 4 | 1 |

a. Number of rollers may increase based on density frequency curve.
b. The compaction roller may be used as the finish roller also.

After placement, roll the HMA mixture as soon after placement as the roller is able to bear without undue displacement or cracking. Start rolling longitudinally at the sides of the lanes and proceed toward the center of the pavement, overlapping on successive trips by at least half the width of the drum. Ensure each required roller is 8 tons minimum in weight unless otherwise approved by the Engineer.

Ensure the initial breakdown roller is capable of vibratory compaction and is a maximum of 500 feet behind the paving operations. The maximum allowable speed of each roller is 3 miles per hour (mph) or 4.5 feet per second. Ensure all compaction rollers complete a minimum of two complete rolling cycles prior to the mat temperature cooling to 180 degrees Fahrenheit (F). Continue finish rolling until all roller marks are eliminated and no further compaction is possible. The Engineer will verify and document that the roller pattern has been adhered to. The Engineer can stop production when the roller pattern is not adhered to.

d. Measurement and Payment. The completed work, as described, will be measured and paid for using applicable pay items as described in subsection 501.04 of the Standard Specifications for Construction, or the contract, except as modified below.

Base Price. Price established by the Department to be used in calculating incentives and adjustments to pay items and shown in the contract.

If acceptance tests, as described in section c. of this special provision, show that a Table 1 mixture parameter exceeds the Range 1, but not the Range 2, tolerance limits, that mixture parameter will be subject to a 10 percent penalty. The 10 percent penalty will be assessed based on the acceptance tests only unless the Contractor requests that the 10,000 gram sample part retained for possible dispute resolution testing be tested. The Contractor has 4 calendar days from receipt of the acceptance test results to notify the Engineer, in writing, that dispute resolution testing is requested. The Contractor's QC test results for the corresponding QA test results must result in an overall payment greater than QA test results otherwise the QA tests will not be allowed to be disputed. The Engineer has 4 calendar days to send the dispute resolution sample to the lab once dispute resolution testing is requested. The dispute resolution sample will be sent to an independent lab selected by the Local Agency, and the resultant dispute test results will be used to determine the penalty per parameter, if any. Ensure the independent lab is a MDOT QA/QC qualified lab or an AMRL HMA qualified lab. The independent lab must not have conflicts of interest with the Contractor or Local Agency. If the dispute testing results show that the mixture parameter is out-of-specification, the Contractor will pay for the cost of the dispute resolution testing and the contract base price for the material will be adjusted, based on all test result parameters from the dispute tests, as shown in Table 3 and Table 4. If the dispute test results do not confirm the mixture parameter is out-of-specification, then the Local Agency will pay for the cost of the dispute resolution testing and no price adjustment is required.

If acceptance tests, as described in section c. of this special provision, show that a Table 1 mixture parameter exceeds the Range 2 tolerance limits, the 10,000 gram sample part retained for possible dispute resolution testing will be sent, within 4 calendar days, to the MDOT Central Laboratory for further testing. The MDOT Central Laboratory's test results will be used to determine the penalty per mixture parameter, if any. If the MDOT Central Laboratory's results do not confirm the mixture parameter is out-of-specification, then no price adjustment is required. If the MDOT Central Laboratory's results show that the mixture is out-of-specification and the Engineer approves leaving the out-of-specification mixture in place, the contract base price for the material will be adjusted, based on all parameters, as shown in Table 3 and Table 4.

In the case that the Contractor disputes the results of the test of the second sample obtained for a particular day of production, the test turn-around time frames given would apply to the second test and there would be no time frame on the first test.

The laboratory (MDOT Central Laboratory or independent lab) will complete all Dispute Resolution testing and return test results to the Engineer, who will provide them to the Contractor, within 13 calendar days upon receiving the Dispute Resolution samples.

In all cases, when penalties are assessed, the penalty applies to each parameter, up to two parameters, that is out of specification.

Table 3: Penalty Per Parameter

| Mixture Parameter out-of-Specification per Acceptance Tests | Mixture Parameter out-of-Specification per Dispute Resolution Test Lab | Price Adjustment per Parameter |
|---|--|--|
| NO | N/A | None |
| YES | NO | None |
| | YES | Outside Range 1 but not Range 2: decrease by 10% |
| | | Outside Range 2: decrease by 25% |

The quantity of material receiving a price adjustment is defined as the material produced from the time the first out-of-specification sample was taken until the time the sample leading to the first in-specification test was taken.

Each parameter of Table 1 is evaluated with the total price adjustment applied to the contract base price based on a sum of the two parameter penalties resulting in the highest total price adjustment as per Table 4. For example, if three parameters are out-of-specification, with two parameters outside Range 1 of Table 1 tolerance limits, but within Range 2 of Table 1 limits and one parameter outside of Range 2 of Table 1 tolerance limits and the Engineer approves leaving the mixture in place, the total price adjustment for that quantity of material is 35 percent.

Table 4: Calculating Total Price Adjustment

| Cost Adjustment as a Sum of the Two Highest Parameter Penalties | | |
|---|---|------------------------|
| Number of Parameters Out-of-Specification | Range(s) Outside of Tolerance Limits of Table 1 per Parameter | Total Price Adjustment |
| One | Range 1 | 10% |
| | Range 2 | 25% |
| Two | Range 1 & Range 1 | 20% |
| | Range 1 & Range 2 | 35% |
| | Range 2 & Range 2 | 50% |
| Three | Range 1, Range 1 & Range 1 | 20% |
| | Range 1, Range 1 & Range 2 | 35% |
| | Range 1, Range 2 & Range 2 | 50% |
| | Range 2, Range 2 & Range 2 | 50% |

Table 5: Density Frequency Curve Development

Tested by: _____ Date/Time: _____

| | | |
|-----------------------------|----------|-----------|
| Route/Location: | | Air Temp: |
| Control Section/Job Number: | | Weather: |
| Mix Type: | Tonnage: | Gauge: |
| Producer: | Depth: | Gmm: |

Roller #1 Type:

| Pass No. | Density | Temperature | Comments |
|----------|---------|-------------|----------|
| 1 | | | |
| 2 | | | |
| 3 | | | |
| 4 | | | |
| 5 | | | |
| 6 | | | |
| 7 | | | |
| 8 | | | |
| Optimum | | | |

Roller #2 Type:

| Pass No. | Density | Temperature | Comments |
|----------|---------|-------------|----------|
| 1 | | | |
| 2 | | | |
| 3 | | | |
| 4 | | | |
| 5 | | | |
| 6 | | | |
| 7 | | | |
| 8 | | | |
| Optimum | | | |

Roller #3 Type:

| Pass No. | Density | Temperature | Comments |
|----------|---------|-------------|----------|
| 1 | | | |
| 2 | | | |
| 3 | | | |
| 4 | | | |
| 5 | | | |
| 6 | | | |
| 7 | | | |
| 8 | | | |
| Optimum | | | |

Summary: _____

MICHIGAN
DEPARTMENT OF TRANSPORTATION

SPECIAL PROVISION
FOR
WET REFLECTIVE LIQUID APPLIED PAVEMENT MARKINGS

PMK:MKB

1 of 2

APPR:MWB:DBP:03-24-16

FHWA:APPR:03-24-16

a. Description. This work consists of furnishing and installing wet night retroreflective (WR) beads and/or elements and liquid applied pavement marking materials.

b. Materials.

1. Wet Night Retroreflective Beads and/or Elements. Select WR beads and/or elements from one of the following Manufacturers or a Department approved alternative that meets the requirements in Table 1:

3M Corporation
Potter's Industries
Swarco
Flex-o-Lite

Table 1: WR Markings

| Average Initial Retroreflectivity at 30 meter geometry in mcd/lux/m ² | | |
|--|-------|--------|
| Test Method | Color | |
| | White | Yellow |
| Dry (ASTM E 1710) | 700 | 500 |
| Wet Recovery (ASTM E 2177) | 250 | 200 |

Ship the material to the job site in sturdy containers marked in accordance with subsection 920.01.A of the Standard Specifications for Construction.

Submit to the Engineer prior to the start of work:

A. The Manufacturer's recommended application rate of the beads/elements and the liquid applied pavement marking binder to be used on the project. If the Manufacturer's recommended application rate differs from the specified rate in Table 811-1 of the Standard Specifications for Construction, the Manufacturer's recommended rate supersedes the table values.

B. Certification from the Manufacturer that when applied according to their application recommendations the beads and/or elements meet the requirements shown in Table 1 above.

2. Binder. Provide a liquid pavement marking product of the binder type specified in the contract documents from section 811 of the Qualified Products List or as specified by special provision, or use an alternative binder as approved by the Engineer.

c. Construction. Place the binder and beads in accordance with the Manufacturers' recommendations and sections 811 and 920 of the Standard Specifications for Construction except as noted above.

d. Measurement and Payment. The completed work, as described, will be measured and paid for at contract unit prices using the following pay items:

| Pay Item | Pay Unit |
|--|-----------------|
| Pavt Mrkg, Wet Retrflec (binder), __ inch, (color) | Foot |

MICHIGAN
DEPARTMENT OF TRANSPORTATION

SPECIAL PROVISION
FOR
WORK ZONE SIGNING ON LOCAL AGENCY PROJECTS

OPR:MWB

1 of 3

APPR:MSBJKG:09-25-06
FHWA:APPR:06-01-11

a. Description. In addition to all other maintaining traffic signs required on this project, place work zone signing in accordance to the MDOT Traffic and Safety *Maintaining Traffic Typical(s)* contained in the proposal, except as modified herein.

On all "Advance Signing Treatment..." *Maintaining Traffic Typical(s)* (M0030 - M0080):

Replace the R5-18b sign "INJURE/KILL A WORKER \$7500 + 15 YEARS" sign with the R5-18bLA "INJURE/KILL A WORKER // FINE - \$ 7500 // JAIL - 15 YRS" sign, as detailed in the attached graphics.

Delete the R5-18 "TRAFFIC FINES DOUBLED IN WORK ZONES" sign or the R5-18a "TO PROTECT HIGHWAY WORKERS FINES DOUBLED IN WORK ZONES" sign, along with the prescribed 'D' spacing distance.

On all other "Typical Temporary Traffic Control..." *Maintaining Traffic Typical(s)* (M0110 et. al.):

Replace the R5-18c "WORK ZONE BEGINS" sign with the R5-18cLA "WORK ZONE BEGINS // TRAFFIC FINES DOUBLED" sign, as detailed in the attached graphics.

Place the G20-1 "ROAD WORK NEXT ___ MILES" sign and the G20-2 "END ROAD WORK" sign in accordance to the appropriate MDOT Traffic and Safety *Maintaining Traffic Typical*.

Place all other work zone signing in accordance to the project plans and specifications, including the appropriate MDOT Traffic and Safety *Maintaining Traffic Typical(s)*. Place all work zone signing in accordance to the standard specifications.

b. Measurement and Payment. Quantities for Local Agency work zone signs will be included in the plan quantities for the pay items **Sign, Type B, Temp, Furn** and **Sign, Type B, Temp, Oper** or **Sign, Type B, Temp, Prismatic, Furn** and **Sign, Type B, Temp, Prismatic, Oper**. Payment for the signs will be made at the contract unit prices.

MICHIGAN
DEPARTMENT OF TRANSPORTATION

SPECIAL PROVISION
FOR
TRAFFIC CONTROL QUALITY AND COMPLIANCE

OPR:JJG

1 of 2

APPR:CER:DBP:01-20-11
FHWA:APPR:06-20-11

Delete the subsection 812.03.C, Deficient Traffic Control Operations on page 601 of the Standard Specifications for Construction in its entirety, and replace with the following.

C. Deficient Traffic Control Operations.

1. Traffic Control Quality and Compliance. The following applies to all aspects of the traffic control plan and traffic control devices except the Type D lights on plastic drums which are covered elsewhere in the contract.

a. Traffic Control not Anticipated in Design. If at any time during the project, including the time during the seasonal suspension, the Engineer documents that the traffic control requires improvements beyond the scope of the Traffic Control Plan, the Engineer will provide written instructions to the Contractor and traffic control supplier what improvements are required. The Contractor must develop and submit to the Engineer for approval, a written implementation schedule for improvements. If the schedule is not approved, or if the schedule is approved but is not followed, the Department will adjust the contract according to subsection 812.03.C.1.c.iii. If the implementation schedule is not followed, the Engineer will notify the Contractor and traffic control supplier in writing that they are in violation of this subsection. The work of making traffic control improvements directed by the Engineer that are beyond the scope of the Traffic Control Plan will be paid for as extra work.

b. As Designed Traffic Control. If at any time during the project, including the time during the seasonal suspension, the Engineer documents that the traffic control is deficient, inadequate or improperly placed, the Engineer will provide written notification with instructions for corrective action to the Contractor and traffic control supplier. Upon receipt of the notification of corrective action, the Contractor has 4 hours to correct the traffic control. If the traffic control cannot be corrected within the 4 hour time period, the Contractor will develop a written implementation schedule for the corrective action and submit the schedule to the Engineer for approval within 1 hour of receiving the written notification. If the schedule is not approved, or if the schedule is approved but is not followed, the Department will adjust the contract according to subsection 812.03.C.1.c.iii. If the implementation schedule is not followed, the Engineer will notify the Contractor and traffic control supplier in writing that they are in violation of this subsection.

c. Corrective Action. The Engineer will give written notification to the Contractor as identified above. Failure to make corrections within the timeframe required may result in the following actions by the Engineer:

- i. Stop work on the project until the Contractor completes corrective action,
- ii. Order corrective action by others in accordance with subsection 107.07, subsection 108.02, subsection 812.03.B, and in the interest of public safety.
- iii. A contract price adjustment will be made in the amount of \$100 per hour for every hour or portion thereof the improvements or corrective action remains incomplete as described herein. If improvements or corrections have not been made to the satisfaction of the Department, the contract will be adjusted until the traffic control is acceptable.

MICHIGAN
DEPARTMENT OF TRANSPORTATION

SPECIAL PROVISION
FOR
**MINOR TRAFFIC DEVICES AND TRAFFIC REGULATOR CONTROL DURING AN
APPROVED EXTENSION OF TIME**

OPR:CRB

1 of 1

APPR:JJG:DBP:09-27-12

FHWA:APPR:10-04-12

Delete the first sentence of the second paragraph in subsection 812.04.U, Price Adjustments for Authorized Extensions of Time, on page 631 of the Standard Specifications for Construction and replace with the following.

The Department will not make price adjustments for temporary traffic control devices, Minor Traf Devices, and Traf Regulator Control during authorized extensions of time if liquidated damages are assessed in accordance with subsection 108.08 and subsection 108.09.

Delete the third paragraph and Formula 812-1 of subsection 812.04.U, Price Adjustments for Authorized Extensions of Time, on page 631 of the Standard Specifications for Construction, that starts with “The Department will use the following formula...” and replace with the following.

The Department will use the following formula to calculate the unit price adjustments. The adjustment for Minor Traf Devices will be at a daily rate of (a/b) not to exceed \$900.00 per calendar or work day and the adjustment for Traf Regulator Control will be at a daily rate of (a/b) not to exceed \$650.00 per calendar or work day. When calculating the adjustment, either calendar or working days will be used for both original contract time and additional days.

$a/b \times c =$ Unit price adjustment

Formula 812-1

where:

a = Original contract unit price.

b = Original contract time (For calendar date projects the original contract time will be calculated as the number of calendar days from the start date to the contract completion date as identified on the progress schedule, form 1130).

c = Additional days the item was in use or required to be on standby during the authorized extension of time.

MICHIGAN
DEPARTMENT OF TRANSPORTATION

SPECIAL PROVISION
FOR
PRICE ADJUSTMENTS FOR AUTHORIZED EXTENSIONS OF TIME

CFS:MB

1 of 2

APPR:JYG:CRB:02-01-18
FHWA:APPR:02-02-18

Delete section 812.04.U, Price Adjustments for Authorized Extensions of Time, on page 631 and 632 of the Standard Specifications for Construction in its entirety and replace with the following.

U. Price Adjustments for Authorized Extensions of Time. The Department will not adjust the unit price for **TS, Temp, Furn** for authorized extensions of time.

The Department will not make price adjustments for temporary traffic control devices, **Minor Traf Devices**, and **Traf Regulator Control** during authorized extensions of time if liquidated damages are assessed in accordance with subsection 108.10. If liquidated damages are not assessed, the Department will adjust unit prices for the following:

1. **TS, Temp, Oper;**
2. **PTS System, Temp, Oper;**
3. Items designated as Furnished, Operated, or Standby, unless otherwise specified;
4. Items paid for as Each or Foot as documented by the Department and maintained on the Department website at:
http://www.michigan.gov/mdot/0,4616,7-151-9622_11044_11367---,00.html; and
5. Items measured as lump sum if they are used or required on the worksite during authorized extensions of time except that **Minor Traf Devices** will not be adjusted when conspicuity tape is the only minor traffic control device in service or required during the authorized extension of time.
6. Items not in use reserved by the Engineer as standby.

The Department will use the following formula to calculate the unit price adjustments. The adjustment for **Minor Traf Devices** will be at a daily rate of (A/B) not to exceed \$900.00 per calendar or work day and the adjustment for **Traf Regulator Control** will be at a daily rate of (A/B) not to exceed \$650.00 per calendar or work day. When calculating the adjustment, either calendar or working days will be used for both original contract time and additional days.

$(A/B) \times C = \text{unit price adjustment}$

Formula 812-1

where:

A = Original contract unit price

B = Original contract time

C = Additional days the item was in use or required to be on standby during the authorized extension of time.

The Department will determine the number of additional days the item is on standby or in use in calendar days.

For calendar date projects, the original contract time will be calculated as the number of calendar days from the actual start date to the following order of precedence date as identified within the contract:

- a. The latest Open to Traffic date if removal of all traffic control devices coincides with this date.
- b. The latest interim completion date for each season of work if all contract work must be completed in its entirety except turf establishment and watering and cultivating.
- c. The original contract completion date.

For work day projects if an authorized extension of time extends into the next construction season, including seasonal suspension periods during which a traffic control item is on standby or in use, the original contract time will be the calendar days between the first work day and the expiration of the original contract completion.

MICHIGAN
DEPARTMENT OF TRANSPORTATION

SPECIAL PROVISION
FOR
PAYMENT FOR MINOR TRAFFIC DEVICES AND TRAFFIC REGULATOR CONTROL

OPR:JJG

1 of 1

APPR:BJO:DBP:07-19-11
FHWA:APPR:07-19-11

Delete Table 812-1 in subsection 812.04.E, on page 625 of the Standard Specifications for Construction, in its entirety and replace with the following.

Table 812-1 Partial Payment Schedule for Minor Traf Devices and Traffic Regulator Control

| Percent of Original Contract Amount Earned | Total Percent of Unit Price Paid |
|--|----------------------------------|
| First Use | 15 |
| 25 | 30 |
| 50 | 55 |
| 75 | 80 |
| 90 | 100 |

MICHIGAN
DEPARTMENT OF TRANSPORTATION

SPECIAL PROVISION
FOR
TEMPORARY PEDESTRIAN TYPE II BARRICADE

OFS:RAL

1 of 2

APPR:CAL:CT:08-02-16

a. Description. This work consists of furnishing, installing, maintaining, relocating, and removing a temporary pedestrian Type II barricade section as identified in the proposal or on the plans. Use temporary pedestrian Type II barricades to close non-motorized facilities including sidewalks, bicycle paths, pedestrian paths, and shared use paths that are not part of the roadway. One pedestrian Type II barricade is defined as a barricade section at least 43 inches wide, including all supports, ballast, and hardware.

b. Materials. Provide a temporary pedestrian Type II barricade that meets the requirements of *National Cooperative Highway Research Program Report 350 (NCHRP 350)* or *Manual for Assessing Safety Hardware (MASH)*, in addition to meeting the following requirements:

1. Provide barricade sections at least 43 inches wide, designed to interconnect to ensure a continuous *Americans with Disabilities Act (ADA)* compliant tactile barrier. Ensure the connection includes provisions to accommodate non-linear alignment as well as variations in elevation at the installation area.

2. Ensure the top surface of the barricade is designed to function as a hand-trailing edge, and has a height between 32 and 38 inches. Ensure the lower edge of the barricade is no more than 2 inches above the surface of the non-motorized facility. Ensure the top edge of the bottom rail of the barricade is a minimum of 8 inches above the surface of the non-motorized facility. The barricade may have a solid continuous face. Finally, all features on the front face of the barricade (the face in contact with pedestrians) must share a common vertical plane.

3. Equip both sides of the barricade with bands of alternating 6-inch wide orange and white vertical stripes of reflective sheeting. Two bands of sheeting 6 inches tall and a minimum of 36 inches long containing at least two orange and two white stripes each are required. One band placed near the top and one near the bottom if the barricade section has a solid face. If the barricade consists of two rails, affix one band of sheeting to each rail. Ensure the stripes of reflective sheeting are aligned vertically. Ensure this sheeting meets or exceeds the requirements of *ASTM D 4956* Type IV sheeting.

c. Construction. Construct the temporary pedestrian Type II barricade in accordance with the manufacturer's recommendations, Michigan Manual on Uniform Traffic Control Devices (MMUTCD), the plans, and the following requirements:

1. Install the barricade as shown on the plans and as directed by the Engineer. Interconnect all barricade sections using hinge components if necessary to ensure a continuous detectable edge for the entire installation. Ensure the barricade is ballasted according to the manufacturer's recommendations to ensure stability during wind events and contact with pedestrians.

2. When the barricade is installed near motor vehicle traffic, ensure reflective sheeting is visible to motorists.

3. When pedestrian Type II barricades are used to close a non-motorized facility, ensure a sufficient number of barricade sections are used to block the entire width of the facility. The barricade may extend outside the edge of the non-motorized facility but must not be less than the full width of the facility.

4. If sections of multiple colored barriers are used (i.e. safety orange and white) install the sections such that the colors alternate to increase conspicuity.

5. Ensure pedestrian Type II barricades are not used to close a motor vehicle facility. Ensure these barricades are not used to guide pedestrian traffic on a motor vehicle facility in the presence of active traffic. This prohibition includes bicycle/shared use lanes or shoulders in the presence of active traffic.

d. Measurement and Payment. The completed work, as described, will be measured and paid for at the contract unit price using the following pay item:

| Pay Item | Pay Unit |
|--|-----------------|
| Pedestrian Type II Barricade, Temp | Each |

Pedestrian Type II Barricade, Temp, includes all labor, equipment, and materials to furnish, install, maintain, relocate, and remove one barricade section that is at least 43 inches wide. Additional payment will not be made if wider sections are provided. This includes all rails, supports, ballast, hinge points, reflective sheeting, and miscellaneous hardware needed to install and maintain a barricade section.

MICHIGAN
DEPARTMENT OF TRANSPORTATION

SPECIAL PROVISION
FOR
SUPPORTS FOR TEMPORARY SIGNS

OPR:CRB

1 of 1

APPR:MWB:DBP:06-26-12
FHWA:APPR:08-18-12

Delete the last paragraph of subsection 812.03.D.3, on page 604 of the Standard Specifications for Construction in its entirety, and replace with the following.

Mount construction signs on portable sign support standards only if signs are to remain in place for 14 days or less, or as allowed by the Engineer if fixed supports are not possible.

MICHIGAN
DEPARTMENT OF TRANSPORTATION

SPECIAL PROVISION
FOR
SECURITY OF PORTABLE CHANGEABLE MESSAGE SIGNS

OFS:CRB

1 of 1

APPR:LWB:DBP:10-09-13
FHWA:APPR:10-09-13

a. Description. This work consists of making certain the portable changeable message sign (PCMS) is secure, and complies with the following:

1. Create unique usernames and passwords (not defaults) for access to the PCMS local controls.
2. Remove all literature (manuals, instructions, etc.) from the PCMS controller enclosure.
3. Use a padlock, keyed lock, etc to prevent access to the controller enclosure.
4. Provide the Engineer up to 3 keys, or the lock combination, as well as the usernames and passwords.
5. Provide at minimum, one classroom style training session of 2 hours, on PCMS field equipment, including but not limited to: posting and removal of messages, diagnosing field equipment malfunctions including messaging and communications errors. All training schedules, syllabus and materials are to be supplied by the Contractor and approved by the Engineer prior to delivery of training. Unless otherwise specified by the Engineer, the number of participants at each training session will be limited to a maximum of 20 individuals

MDOT reserves the right to take full messaging control of any PCMS at any time throughout the duration of the project. This includes posting any message determined to be appropriate by MDOT

MDOT may, at any time, inspect PCMS boards that are on site to verify that the security measures in this special provision are being followed.

MICHIGAN
DEPARTMENT OF TRANSPORTATION

SPECIAL PROVISION
FOR
MEASUREMENT AND PAYMENT OF TEMPORARY TRAFFIC CONTROL DEVICES

OFS:CRB

1 of 1

APPR:MWB:JJG:02-27-14

FHWA:APPR:03-04-14

Delete subsection 812.04.A.4, on page 624 of the Standard Specifications for Construction in its entirety.

Delete the second paragraph of subsection 812.04.C, on page 624 of the Standard Specifications for Construction in its entirety, and replace with the following:

The Engineer will measure **Sign, Type __, Temp, Prismatic, Furn** as the total cumulative area of the maximum number of each sign legend that is in use during the course of the project unless previously paid. The unit price for **Sign, Type __, Temp, Prismatic, Furn** includes the cost of portable or driven sign supports.

Delete the second paragraph of subsection 812.04.D, on page 624 of the Standard Specifications for Construction in its entirety, and replace with the following:

The Engineer will measure **Sign, Type __, Temp, Prismatic, Oper** as the total cumulative area of the maximum number of each sign legend that is in use during the course of the project unless previously paid.

MICHIGAN
DEPARTMENT OF TRANSPORTATION

SPECIAL PROVISION
FOR
LONGITUDINAL PAVEMENT MARKING REMOVAL

OFS:CGB

1 of 2

APPR:MWB:JJG:02-26-14
FHWA:APPR:03-13-14

Delete subsection 812.03.F, on pages 615 and 616 of the Standard Specifications for Construction, in its entirety and replace it with the following:

F. Pavement Marking Removal. Remove pavement markings that conflict with proposed temporary traffic markings before making any changes in the traffic pattern. Place temporary pavement markings when pavement markings are removed or obscured for more than 24 hours before a change in the traffic pattern. Type R markings must be placed according to subsection 812.03.D.11 before the close of the workday.

Remove pavement markings using self-propelled truck mounted removal equipment. Use equipment capable of continuously vacuuming up the removal debris as the operation progresses. Immediately clean up and remove any debris that is generated. If the amount of debris generated during the removal process is greater than the vacuuming capability of the removal truck, a self-propelled sweeper operating immediately behind the removal equipment is required. Use a removal truck capable of eliminating the airborne dust while operating.

Remove pavement markings causing as little damage as possible to the surface texture of the pavement and by methods approved by the Engineer. Methods and equipment that may provide acceptable results are: shot blasting; water blasting; mechanical devices such as grinders, scarifiers, and wire brushes.

1. Asphalt Surfaces. Use any Engineer approved type of self-propelled truck mounted removal equipment except water blasting, provided that the equipment is capable of continually vacuuming the removal debris.

2. Concrete Surfaces to be Removed During Construction. Use any Engineer approved type of self-propelled truck mounted removal equipment provided that the equipment is capable of continually vacuuming the removal debris.

3. Concrete Surfaces to Remain in Place. Use an Engineer approved self-propelled truck mounted water blaster to minimize the scarring of the concrete surface. Use equipment capable of continually vacuuming the removal debris as approved by the Engineer.

Do not use paint or bituminous bond coat to cover existing and not applicable pavement markings. Use Type R markings only when authorized by the Engineer.

Add the following pay items to the Pay Item list in subsection 812.04, on pages 622 and 623 of the Standard Specifications for Construction:

| | |
|---|------|
| Pavt Mrkg, Longit, Water Blasting, 6 inch or less Width, Rem | Foot |
| Pavt Mrkg, Longit, Water Blasting, Greater than 6 inch Width, Rem | Foot |

Delete the first paragraph of subsection 812.04.N.1, on pages 628 and 629 of the Standard Specifications for Construction, in its entirety and replace it with the following:

1. **General.** The Department will pay for the removal of longitudinal markings as directed by the Engineer on all HMA surfaces and on concrete surfaces to be removed as **Pavt Mrkg, Longit, Rem**, of the width required. The unit prices for **Pavt Mrkg, Longit, Rem** pay items include the cost of removing existing longitudinal permanent markings and temporary Type NR markings, including tapers and transitions.

The Department will pay for the removal of longitudinal markings on concrete surfaces to remain in place as **Pavt Mrkg, Longit, Water Blasting, Rem**, of the width required. The unit prices for **Pavt Mrkg, Longit, Water Blasting, Rem** pay items include the cost of removing existing longitudinal permanent markings and temporary Type NR markings, including tapers, and transitions.

MICHIGAN
DEPARTMENT OF TRANSPORTATION

SPECIAL PROVISION
FOR
TYPE III BARRICADES

DES:DBP

1 of 1

APPR:MWB:CRB:08-07-15
FHWA:APPR:08-23-15

Delete the first sentence for the second paragraph in subsection 812.03.D.8 on page 606 of the Standard Specifications for Construction, and replace with the following:

Light Type III barricades with two, Type C or Type D warning lights, fastened to the uprights above the top rail, provided these warning lights each weigh 3.3 pounds or less.

Delete the following pay items from the list in subsection 812.04 on page 622 of the Standard Specifications for Construction.

- Barricade, Type III, High Intensity, Furn.....Each
- Barricade, Type III, High Intensity, OperEach
- Barricade, Type III, High Intensity, Double Sided, FurnEach
- Barricade, Type III, High Intensity, Double Sided, OperEach

Renumber the existing subsection 812.04.A.5 on page 624 of the Standard Specifications for Construction, as follows:

- 4. The manufacturer’s invoiced cost for damaged equipment included in a lump sum pay item for maintaining traffic.

MICHIGAN
DEPARTMENT OF TRANSPORTATION

SPECIAL PROVISION
FOR
TEMPORARY PAVEMENT MARKING REVISIONS

OFS:CGB

1 of 4

APPR:MWB:MKB:02-12-16
FHWA:APPR:02-23-16

Delete subsection 812.03.D.11.a, on page 610 of the Standard Specifications for Construction, in its entirety and replace with the following:

- a. **Temporary Pavement Marking – Wet Reflective Type R.** Use temporary wet reflective pavement marking Type R (removable tape) when temporary pavement markings must be placed on finished pavements and are not in the exact location as future permanent markings or at the discretion of the Engineer when temporary markings must be removed during the life of a project.

Ensure prior to installation the pavement surface is air blown or brushed to remove surface dust and dirt. Remove curing compound from new concrete surfaces before applying Type R Tape.

Place wet reflective Type R tape when it is used as a 4-foot dash or full length skip line as defined in the contract to temporarily mark finished pavement prior to the placement of permanent markings according to the Manufacturer's specifications for existing temperature and pavement condition. Offset it 1 foot from the permanent marking so that the permanent markings can be placed prior to the removal of the 4-foot dashes or full length skip line. Do not use 4-foot dashes or full length skip lines to temporarily mark a solid edge line. Ensure damaged or missing tape of more than 2 consecutive skip lines, is replaced at no cost to the Department within 24 hours after notification by the Engineer. Failure to replace the tape within the 24 hour time period will result in a contract price adjustment as described in the Special Provision for Traffic Control Quality and Compliance.

- i. Between April 15 and November 1, place wet reflective Type R tape not used as a skip line according to the Manufacturer's specifications for existing temperature and pavement condition. Replace wet reflective Type R tape of more than 50 cumulative feet that fails, at no cost to the Department within 24 hours after notification by the Engineer. Failure to replace the tape within the 24 hour time period will result in a contract price adjustment as described in the Special Provision for Traffic Control Quality and Compliance.
- ii. From November 2 to December 1 and March 15 to April 14, place wet reflective Type R tape for all temporary shifts and tapers when pavement surfaces are dry and air temperatures are 40 degrees Fahrenheit and rising. All wet reflective Type R tape placed during these times must be placed during approved daytime hours negotiated between the Engineer and the Contractor or daytime hours required in the contract. Do not place wet reflective Type R tape within 24 hours of predicted precipitation, or 24 hours after any precipitation. The Contractor will be paid to

repair locations that fail during these times unless the Engineer determines the failure is due to improper surface preparation, or failure to follow these requirements. Repairs, if required, will be paid for at a negotiated price between the Engineer and the Contractor for the associated work.

- iii. Use temporary wet reflective pavement marking Type NR paint, for all tapers and shifts when ambient air temperature is less than 40 degrees Fahrenheit. To remove the wet reflective Type NR paint, use the least abrasive technique as directed by the Engineer to minimize scarring. If the approved pavement marking removal pay item is not part of the contract, the cost of the removal of Type NR pavement markings will be negotiated between the Engineer and the Contractor.
- iv. Wet reflective Type R tape is not to be placed between December 2 and March 14.

Delete subsection 812.03.D.11.b, on page 610 of the Standard Specifications for Construction, in its entirety and replace with the following:

b. Temporary Pavement Marking.

- i. **Wet Reflective Type NR Paint.** Use temporary pavement marking Wet Reflective Type NR paint when temporary pavement markings must be placed on pavement to be removed or replaced during construction. They also must be used when temporary markings line up exactly with the placement of permanent markings and may be grooved out prior to recessing permanent markings. The temporary pavement marking material must be compatible with the material specified for the permanent markings if permanent markings are to be placed on top of temporary markings.

Place Wet Reflective Type NR paint in accordance with section 811. Place the material at a thickness of 18 mils while driving at a maximum rate of 8 miles per hour. Drop WR optics from the forward most bead applicator gun at a rate of 4 pounds per gallon. Drop glass beads at a rate of 6 pounds per gallon from the rear bead applicator gun.

Place Wet Reflective Type NR paint, used as a 4-foot dash or full length skip line as defined in the contract, to temporarily mark finished pavement prior to the placement of permanent markings, in the exact location as the permanent marking such that its removal is not necessary. Only use Wet Reflective Type NR markings compatible with the permanent pavement marking material specified on the project as a 4-foot dash or full length skip line. Do not use 4-foot dashes or full length skip lines to temporarily mark a solid edgeline.

- ii. **Type NR Tape.** Use temporary pavement marking Type NR Tape as a 4 foot dash or full length skip line as defined in the contract to temporarily mark a white skip line or yellow centerline on base or leveling course of pavement. Type NR tape must not be used to temporarily mark a solid edgeline. Type NR tape is not to be used on the wearing course of asphalt or on existing pavement.

Place Type NR tape in accordance with section 811.

Delete the following pay items from the list of pay items in subsection 812.04, on page 623 of the Standard Specifications for Construction:

Pavt Mrkg, Type R, 4 inch, (color), TempFoot
 Pavt Mrkg, Type NR, Paint, 4 inch, (color), TempFoot

Add the following pay items to the list of pay items in subsection 812.04, on page 623 of the Standard Specifications for Construction:

Pavt Mrkg, Wet Reflective, Type R, Tape, 4 inch, (color), TempFoot
 Pavt Mrkg, Wet Reflective, Type NR, Paint, 4 inch, (color), TempFoot

Delete subsection 812.04.N.2, on page 629 of the Standard Specifications for Construction, in its entirety and replace with the following:

2. **Non-Removable (Type NR) Pavement Markings.** The unit price for the relevant **Pavt Mrkg, Wet Reflective, Type NR, Paint, Temp** and **Pavt Mrkg, Type NR, Tape, Temp** pay items include the cost of providing and placing temporary pavement markings.

Delete subsection 812.04.N.3, on page 629 of the Standard Specifications for Construction, in its entirety and replace with the following:

3. **Removable (Type R) Pavement Markings.** The unit prices for **Pavt Mrkg, Wet Reflective, Type R, Tape, 4 inch, (color), Temp** and **Pavt Mrkg Cover, Type R, (color)** include the cost of providing, placing, maintaining, removing and disposing of temporary pavement marking. Payment will be per foot measured along the length of the placed pavement marking except for 8 inch gore markings and double solid lines which will be two times their measured length.

Delete subsection 922.06.A.1 on page 937 of the Standard Specifications for Construction in its entirety and replace with the following:

1. **Pavement Marking, Wet Reflective, Type R.** Provide wet reflective Type R temporary pavement marking as preformed tape. Select wet reflective Type R markings from the Qualified Products List (922.06A). Apply and remove preformed tape in accordance with the manufacturer's instructions. The tape must remain flexible and conform to the texture of the pavement surface during use.

Delete subsection 922.06.A.2, on page 937 of the Standard Specifications for Construction, in its entirety and replace with the following:

2. **Pavement Marking, Wet Reflective, Type NR Paint.** Provide Wet Reflective Type NR temporary pavement markings as paint reflectorized with glass beads and wet

reflective optics, as required.

- a. **Wet Night Retro Reflective Optics.** Select WR optics from one of the following Manufacturers or a Department approved alternative that meets or exceeds the requirements in Table 922-2:

3M Corporation
Potter's Industries
Swarco

| Table 922-2 Temporary Wet Reflective Type NR Pavement Markings | | |
|--|-------|--------|
| Average Initial Retro reflectivity at 30 meter geometry in mcd/lux/sq m with flow of placement | | |
| Test Method | Color | |
| | White | Yellow |
| Dry (<i>ASTM E 1710</i>) | 700 | 500 |
| Wet Recovery (<i>ASTM E 2177</i>) | 250 | 200 |

Ship the material to the job site or Contractor's yard in sturdy containers marked in accordance with subsection 920.01.A.

Select glass beads for corresponding materials in accordance to subsection 920.02.

Submit to the Engineer prior to the start of work a general certification from the Manufacturer that when applied according to the construction methods herein, the glass beads and optics will meet the minimum requirements shown in Table 922-2.

- b. **Binder Material for Temporary Wet Reflective Type NR Pavement Markings.** Select the liquid applied pavement marking from one of the following materials from the Qualified Products List to use as a binder for the WR optics or use an alternative as approved by the Engineer:

811.03D1 Waterborne, Liquid Pavement Marking Material
811.03D2 Low Temperature Waterborne, Liquid Pavement Marking Material
811.03D3 Regular Dry Paint, Liquid Pavement Marking Material

3. **Pavement Marking, Type NR Tape.** Provide Type NR temporary pavement markings as preformed tape reflectorized with glass beads, as required. The tape must remain flexible and conform to the texture of the pavement surface during use. Select Type NR tape from the Qualified Products List (922.06A).

MICHIGAN
DEPARTMENT OF TRANSPORTATION

SPECIAL PROVISION
FOR
PAYMENT OF TEMPORARY TRAFFIC CONTROL DEVICES

OFS:CRB

1 of 1

APPR:CGB:MB:08-26-16
FHWA:APPR:09-13-16

Delete subsection 812.04.A Damage Compensation, on page 623 of the Standard Specifications for Construction, in its entirety and replace with the following:

A. Damage Compensation. Notify the Engineer of damaged temporary traffic control devices. Before replacement and disposal, allow the Engineer to verify the condition of damaged temporary traffic control devices eligible for payment. Damage will be assumed to have occurred from vehicular traffic unless otherwise documented. The Department will pay as follows, for replacing temporary traffic control devices or equipment that are placed appropriately and damaged by vehicular traffic, other than the Contractor's vehicles and equipment.. Devices will be assumed to be placed appropriately unless otherwise documented. Replacement will be made up to project completion (excluding water and cultivating), as follows:

1. The **Furnished** unit price for temporary traffic control devices paid for as furnished pay items, excluding Plastic Drums and 42 inch channelizing devices;
2. The unit price for devices not paid for as **Furnished**;
 - a. Plastic Drums and 42 inch Channelizing Devices will be paid for at a set rate of \$35 per Plastic Drum and \$18 per damaged 42 inch Channelizer.
 - i. Prior to payment the Plastic Drum or 42 inch Channeling Device must be classified as unacceptable, per the ATSSA Quality Guidelines for Temporary Traffic Control Devices and Features (ATSSA QG), and spray-painted with an X.
 - ii. All Plastic Drums and 42 inch Channelizing Devices that are classified as marginal, per the ATSSA QG, during the project, will have blue survey ribbon tied to the handle. MDOT will be responsible for marking marginal devices. Removal and replacement will take place as defined under the Quality Classifications and Requirements Section of the ATSSA QG and will be at no additional cost to the Department.
 - If at any time, any Contactor, is witnessed tampering with the marginal marking method, the Engineer may require all marginal devices on the project to be upgraded to acceptable outside the timeframes detailed in the ATSSA QG.
3. The manufacturer's invoice cost for devices required by the Engineer and not included in the unit price for other relevant pay items;
4. The manufacturer's invoiced cost for damaged equipment included in a lump sum pay item for maintaining traffic.

MICHIGAN
DEPARTMENT OF TRANSPORTATION

SPECIAL PROVISION
FOR
USE OF 42-INCH CHANNELIZING DEVICES

OFS:RAL

1 of 1

APPR:CRB:MB:06-30-17
FHWA:APPR:07-21-17

Delete subsection 812.03.D.6, on page 605 of the Standard Specifications in its entirety and replace it with the following:

6. **42-inch Channelizing Devices.** Provide and install 42-inch tall, retro-reflective plastic channelizing devices as shown on the plans, or directed by the Engineer. Do not attach lights.
- a. **Daytime Use.** The Department will allow the daytime use of 42-inch channelizing devices in tapers and tangents for the following:
- i. Capital Preventative Maintenance (CPM) projects, pavement marking, chip seal, microsurface, and crack-filling projects;
 - ii. Any projects where the use of plastic drums restricts proposed lane widths to less than 11 feet, including shy distance; or
 - iii. Work durations of 12 hours or less.

The devices must be placed such that spacing does not exceed the maximum values described in Table 812-1:

| Table 812-1 | | |
|---|--------------|----------------|
| Maximum Spacing for 42-inch Channelizing Devices | | |
| Work Zone Speed Limit | Taper | Tangent |
| < 45 mph | 1.0 S | 2.0 S |
| ≥ 45 mph | 50 feet | 100 feet |
| S=Work Zone Speed Limit (mph) | | |

- b. **Nighttime Use.** The Department will allow the nighttime use of 42-inch channelizing devices in tangents and tapers for the following:
- i. Capital Preventative Maintenance (CPM) projects, pavement marking, chip seal, microsurface, and crack-filling projects;
 - ii. Any projects where the use of plastic drums restricts proposed lane widths to less than 11 feet, including shy distance; or
 - iii. Work durations of 12 hours or less.

Place the devices a maximum distance of 50 feet apart in tangent sections, and a maximum of 25 feet apart in tapers. These spacing requirements apply for all speed limits.

MICHIGAN
DEPARTMENT OF TRANSPORTATION

SPECIAL PROVISION
FOR
INDUSTRIAL BY-PRODUCTS AND BENEFICIAL RE-USE

ENV:HLZ

1 of 1

APPR:JJG:JFS:09-11-14

APPR: FHWA: 09-11-14

a. Description. For this project, regardless of the application, the use of industrial by-products, covered in 2014 PA 178, is prohibited unless the use and application of a particular material is covered elsewhere in the contract.

MICHIGAN
DEPARTMENT OF TRANSPORTATION

SPECIAL PROVISION
FOR
SUPERPAVE FINAL AGGREGATE BLEND REQUIREMENTS

CFS:KPK

1 of 2

APPR:JFS:CJB:04-03-15
FHWA:APPR:04-07-15

a. Description. This special provision establishes the Superpave final aggregate blend gradation requirements and the Superpave final aggregate blend physical requirements.

b. Materials. Replace Table 902-5 and Table 902-6 of the Standard Specifications for Construction with the following tables.

| Table 902-5 | | | | | | |
|---|--|----------|----------------------------------|------------------------------|----------|-----------------|
| Superpave Final Aggregate Blend Gradation Requirements | | | | | | |
| Standard Sieve | Percent Passing Criteria (control points) | | | | | |
| | Mixture Number | | | | | |
| | 5 | 4 | 3 Leveling Course | 3 Base Course | 2 | LVSP (a) |
| 1½ inch | — | — | — | — | 100 | — |
| 1 inch | — | — | 100 | 100 | 90–100 | — |
| ¾ inch | — | 100 | 90–100 | 90–100 | ≤90 | 100 |
| ½ inch | 100 | 90–100 | ≤90 | ≤90 | — | 75–95 |
| ⅜ inch | 90–100 | ≤90 | — | — | — | 60–90 |
| No. 4 | ≤90 | — | — | — | — | 45–80 |
| No. 8 | 47-67 | 39-58 | 35–49 | 23–49 | 19–45 | 30–65 |
| No. 16 | — | — | — | — | — | 20–50 |
| No. 30 | — | — | — | — | — | 15–40 |
| No. 50 | — | — | — | — | — | 10–25 |
| No. 100 | — | — | — | — | — | 5–15 |
| No. 200 | 2.0–10.0 | 2.0–10.0 | 2.0–8.0 | 2.0–8.0 | 1.0–7.0 | 3–6 |

a. For LVSP, less than 50 percent of the material passing the No. 4 sieve may pass the No. 30 sieve.

**Table 902-6
Superpave Final Aggregate Blend Physical Requirements**

| Est. Traffic (million ESAL) | Mix Type | Percent Crushed Minimum Criteria | | Fine Aggregate Angularity Minimum Criteria | | % Sand Equivalent Minimum Criteria | | Los Angeles Abrasion % Loss Maximum Criteria | | % Soft Particles Maximum Criteria (a) | | % Flat and Elongated Particles Maximum Criteria (b) | |
|-----------------------------------|-------------|-------------------------------------|----------------|--|----------------|---------------------------------------|----------------|---|----------------|--|----------------|---|----------------|
| | | Top & Leveling Courses | Base Course | Top & Leveling Courses | Base Course | Top & Leveling Courses | Base Course | Top & Leveling Courses | Base Course | Top & Leveling Courses | Base Course | Top & Leveling Courses | Base Course |
| < 0.3 | LVSP | 55/— | — | — | — | 40 | 40 | 45 | 45 | 10 | 10 | — | — |
| < 0.3 | E03 | 55/— | — | — | — | 40 | 40 | 45 | 45 | 10 | 10 | — | — |
| ≥0.3 - <1.0 | E1 | 65/— | — | 40 | — | 40 | 40 | 40 | 45 | 10 | 10 | — | — |
| ≥1.0 - < 3 | E3 | 75/— | 50/— | 43 | 40 | 40 | 40 | 35 | 40 | 5 | 5 | 10 | 10 |
| ≥3 - <10 | E10 | 85/80 | 60/— | 45 | 40 | 45 | 45 | 35 | 40 | 5 | 5 | 10 | 10 |
| ≥10 - <30 | E30 | 95/90 | 80/75 | 45 | 40 | 45 | 45 | 35 | 35 | 3 | 4.5 | 10 | 10 |
| ≥30 - <100 | E50 | 100/100 | 95/90 | 45 | 45 | 50 | 50 | 35 | 35 | 3 | 4.5 | 10 | 10 |

(a) Soft particles maximum is the sum of the shale, siltstone, ochre, coal, clay-ironstone and particles that are structurally weak or are non-durable in service.
(b) Maximum by weight with a 1 to 5 aspect ratio.

Note: "85/80" denotes that 85 percent of the coarse aggregate has one fractured face and 80 percent has at least two fractured faces.

MICHIGAN
DEPARTMENT OF TRANSPORTATION

SPECIAL PROVISION
FOR
**CAPITAL PREVENTIVE MAINTENANCE AGGREGATE BLEND PHYSICAL
REQUIREMENTS**

CFS:SAB

1 of 1

APPR:CG:JFS:10-21-15

FHWA:APPR:10-22-15

Delete the existing Table 902-8 on page 752, of the 2012 Standard Specifications for Construction, in its entirety, including all errata items in 12SS-001A that call for changes to Table 902-8, and replace with the following:

| Table 902-8 CPM Aggregate Blend Physical Requirements | | | | | | | | | | |
|--|----------------------------------|-----------------------------------|--|--|-----------------------|-----------------------------------|---|---|--------------------------------|---|
| Material | Percent Crushed (Min) MTM 117 | Angularity Index (Min) MTM 118 | Uncompacted Void (Min) AASHTO T 304 | Los Angeles Abrasion (% Loss Max) MTM 102 (i) | AWI (Min.) MTM 112 | Soft Particles (% Max) MTM 110 | Sand Equivalent (% Min) AASHTO T 176 | Flat and Elongated (% Max) ASTM D 4791 | Absorp. (% Max) AASHTO T 85 | Mico-Deval (% Loss Max) AASHTO T 327 |
| 27SS (h) | 90 (b) | — | 40 | 35 | 260 | 5.0 (a) | 45 | 25.0 (e) | 3.0 | 18 |
| 30SS (h) | 90 (b) | — | 40 | 35 | 260 | 5.0 (a) | 45 | 25.0 (e) | 3.0 | 18 |
| 34CS | 95 | — | — | 35 (c) | 260 (d) | 3.5 (a) | — | 12.0 (e) | — | — |
| 2FA | — | 4.0 (f) | — | 45 | 260 | — | 60 (g) | — | — | — |
| 3FA | — | 4.0 | — | 45 | 260 | — | 60 | — | — | — |

a. Sum of shale, siltstone, clay-ironstone, and structurally weak.
b. Percent two-faced crushed.
c. L. A. Abrasion maximum loss of 45 for blast furnace slag.
d. Does not apply to shoulder area of the chip seal.
e. For material retained on the No. 4 sieve, ensure the ratio between length to width, or length to thickness, or combination is no greater than 3:1.
f. Angularity Index must exceed 2.0 for at least 50 percent of the blending sands for slurry seal applications.
g. Does not apply to slurry seals.
h. Must be 100% virgin aggregate.
i. If a blend of different aggregate sources, the abrasion value applies to each source

MICHIGAN
DEPARTMENT OF TRANSPORTATION

SPECIAL PROVISION
FOR
PERMANENT PAVEMENT MARKING MATERIALS

PMK:MKB

1 of 1

APPR:MWB:CRB:07-07-16
FHWA:APPR:07-13-16

Delete the first paragraph of subsection 920.01, on page 890 of the 2012 Standard Specifications for Construction in its entirety and replace it with the following:

Select pavement marking materials from the Qualified Products List unless specified otherwise by special provision in the contract. For black liquid shadow markings and blue markings used in parking areas, either choose a product of the specified binder material and color from the Qualified Products List or select a white product of the specified binder material from the Qualified Products List and tint the product to the appropriate color.

Use liquid applied pavement marking materials manufactured in the previous 12 months or within the shelf-life directed by the manufacturer, whichever is less. Use solid applied materials within the shelf-life directed by the manufacturer. Provide certification that liquid and solid applied pavement marking materials have been stored per the manufacturer's requirements. Materials not in compliance will be rejected and removed at the Contractor's expense.

Delete the second paragraph from subsection 920.02.A, on page 891 of the Standard Specifications for Construction in its entirety and replace it with the following:

Glass beads must meet the general requirements of subsection 920.02.B, and the applicable requirements for specific applications of subsection 920.02.C. All glass beads meeting subsections 920.02.B and 920.02.C to be used on Federal-aid projects must contain no more than 200 parts per million of arsenic or lead, as determined in accordance with *Environmental Protection Agency* testing methods 3052, 6010B, or 6010C.

Add the following after the last paragraph of subsection 920.02.C, on page 892 of the 2012 Standard Specifications for Construction:

6. **Modified Urethane.** The type, gradation, and application rates for glass beads used with modified urethane marking material must meet the modified urethane manufacturer's recommendation.

Use a double drop system of large and standard glass beads, a double drop system of ceramic elements and standard glass beads, or an Engineer-approved alternate for recessed longitudinal markings. Ensure large glass beads meet federal specification TTB-1325 for a Type 4 glass bead.

MICHIGAN
DEPARTMENT OF TRANSPORTATION

SPECIAL PROVISION
FOR
GLASS BEADS USED FOR PAVEMENT MARKINGS

PMK:MKB

1 of 1

APPR:MWB:HZ:10-26-12
FHWA:APPR:11-05-12

Delete the second paragraph from subsection 920.02.A, on page 891 of the Standard Specifications for Construction in its entirety and replace it with the following:

Glass beads must meet the general requirements of subsection 920.02.B, and the applicable requirements for specific applications of subsection 920.02.C. All glass beads meeting subsections 920.02.B and 920.02.C to be used on Federal-aid projects must contain no more than 200 parts per million of arsenic or lead, as determined in accordance with *Environmental Protection Agency* testing methods 3052, 6010B, or 6010C.

MICHIGAN
DEPARTMENT OF TRANSPORTATION

SUPPLEMENTAL SPECIFICATION
FOR
ERRATA TO THE 2012 STANDARD SPECIFICATIONS

1 of 30

08-01-17

| Page | Subsection | Errata |
|------|------------|--|
| 3 | 101.02 | Modify the abbreviation reading "AIS" to read "AISI". |
| 4 | 101.02 | Delete the following abbreviations and the long forms MDELEG MDNRE Add the following abbreviations and the long forms MDNR Michigan Department of Natural Resources MDEQ Michigan Department of Environmental Quality MDLARA Michigan Department of Licensing and Regulatory Affairs NESC National Electrical Safety Code |
| 27 | 103.02.B.2 | Change the last sentence of the first paragraph to read "For decreases below 75 percent, the maximum allowable payment for work performed, including any adjustment, will not exceed an amount equal to 75 percent of the original contract quantity times the contract unit price." |
| 34 | 104.05 | The first sentence of this subsection should read "If the Contractor performs unauthorized work (work performed without the inspections required by the contract, extra work performed without Department approval, work performed contrary to the inspectors direction, or work performed while under suspension by the inspector), the Engineer may reject the unauthorized work." |
| 46 | 104.12 | Add the following to the end of the first paragraph "The use of right-of-way in wetlands and floodplains, or the crossing of water courses by construction equipment is prohibited." |
| 53 | 105.09 | Add the following to the end of the second paragraph "Any specifically produced material not purchased by the Department, will remain the Contractors and must be removed from the project prior to final acceptance." |
| 56 | 107.02.B.2 | This sentence should read "U.S.Army Corps of Engineers' Section 404, Dredge and Fill; and Section 10, Navigable Waterway." |
| 56 | 107.02.B | Add the subsection reading as follows: "3. U.S. Coast Guard Section 9, Navigable Waterway." Change "MDNRE" to "MDEQ" in this subsection. |

| Page | Subsection | Errata | | |
|-------------|--------------|--|-------------|-------|
| 64 | 107.12 | Change the first sentence of the first paragraph to read: "For protection of underground utilities and in accordance with 2013 PA 174, the Contractor must notify Miss Dig at least 3 work days, excluding Saturdays, Sundays and holidays, before beginning each excavation in areas where public utilities have not been previously located." | | |
| 65 | 107.15.A | Change "MDNRE" to "MDEQ" in four instances in this subsection. | | |
| 66 | 107.15.A.3 | Add the following to the end of the paragraph "Note that a burn permit from the MDNR is required for any open burning whenever the ground is not snow covered. Any individuals that allow a fire to escape will be in violation of the Natural Resources and Environmental Protection Act and will be required to reimburse the costs of suppressing the wild fire." | | |
| 67* | 107.16 | The third sentence should read "In State Forests, the Contractor must contact the local Unit Manager, Forest Management Division, MDNR, regarding the work to be performed within or adjacent to the forest land." Delete the last sentence of the first paragraph of this subsection. | | |
| 80 | 108.08.F | Delete the second paragraph in its entirety. | | |
| 80 | 108.08.G | Add the following new subsection: "G. The Contractor may propose and the Engineer may approve another equitable method, supported by an acceptable rationale to determine time extensions for any of the excusable delays listed in subsection 108.08. | | |
| 83 | 108.10.C | Change the last sentence of the first paragraph to read: "The liquidated damages may contain one or more components of damages added together." | | |
| 83 | 108.10.C.1 | In Table 108-1 delete the last row of the table and replace it with the following: <table border="1" style="margin-left: 40px;"> <tr> <td>≥50,000,000</td> <td>4,500</td> </tr> </table> | ≥50,000,000 | 4,500 |
| ≥50,000,000 | 4,500 | | | |
| 102 | 109.05.E.1 | Change the second sentence of the third paragraph to read: "Provide the content specified in subsection 109.05.D.11 for the applicable items in this statement and as follows:" | | |
| 107 | 150.04 | Change the following pay item reading "Mobilization, Max ___" to read "Mobilization, Max (dollar)" at nine locations throughout the subsection. | | |
| 112 | 201.03.A.3.b | Change "MDNRE" to "MDNR" in three instances in this subsection. | | |
| 150 | 208.01 | Change "MDNRE" to "MDEQ" in this subsection. | | |
| 180 | 308.03.A | Change the first sentence of the second paragraph to read: | | |

| Page | Subsection | Errata |
|------|------------|---|
| | | "Do not operate equipment required to place backfill directly on geotextile products." |
| 185 | 401.03.A | Change the first sentence of the second paragraph to read: Where unstable soil conditions, or obstructions other than rock, require excavation of the trench below the elevation detailed on the plans; undercut, backfill, and compact the trench as directed by the Engineer. |
| 188 | 401.03.H | Change the second sentence of the paragraph to read "Jack steel pipes in place in accordance with subsection 401.03.G". |
| 189 | 401.03.N | Add the following sentence to the end of the first paragraph "Where possible, maintain the stream flow thru a temporary channel or temporary culvert." The second sentence of the second paragraph should read "Direct water from the dewatering operations through a filter bag before discharging to an existing drainage facility." |
| 189 | 401.04 | Change the fourth pay item from the end of the list to read as follows: "Culv, Reinf Conc Ellip, (shape) CI __, (rise) inch x (span) inch". |
| 190 | 401.04 | Change the fourth pay item from the end of the list to read as follows: "Steel Casing Pipe, __ inch, Tr Det __." |
| 195 | 402.03.C | Change the third sentence of the first paragraph to read as follows: "Wrap pipe joints, with a diameter greater than 24 inches, using geotextile blanket." |
| 200 | 402.04 | Change the third pay item from the top of the list to read as follows: "Sewer, CI __, __ inch, Jacked in Place" |
| 200 | 402.04.A | Change the last sentence of the subsection to read as follows: "The unit price for Sewer and Sewer, Reinf Conc, Ellip includes the cost of excavation, backfill, geotextile blanket and mandrel testing." |
| 201* | 402.04.H | Change the last sentence of the first paragraph to read "The Department will not make an adjustment in the pay items of Minor Traf Devices or Traf Regulator Control ." |
| 208 | 403.04.D.3 | Change the sentence to read: "Removing and replacing pavement adjacent to the adjusted cover per Standard Plan R-37 Series." |
| 218 | 406.03.A.2 | Change the first sentence of the first paragraph to read: "Design precast box culverts less than 10 feet in span length measured along the centerline of the roadway in accordance with current AASHTO LRFD Bridge Design Specifications and ASTM C 1577." Add the following sentence to the end of the first paragraph: |

| Page | Subsection | Errata |
|-------------|-------------------|--|
| | | “Design precast box culverts greater than or equal to 10 feet in span length measured along the centerline of the roadway for HL-93 Modified live load.” |
| 219 | 406.03.B | Change the first sentence of the first paragraph to read: “Submit shop drawings for culverts greater than or equal to 10 feet in span length measured along the centerline of the roadway to the Engineer, for review and approval in accordance with subsection 104.02.” |
| 219 | 406.03.C.1 | Change the second sentence of the first paragraph to read: “Before manufacture, perform load ratings on precast three-sided, arch or box culverts greater than or equal to 10 feet in span length measured along the centerline of the roadway, in accordance with the AASHTO Manual of Bridge Evaluation, Section 6, Part A, the Michigan Bridge Analysis Guide current at the time load rating is performed, and the Michigan Structure Inventory and Appraisal Guide.” |
| 223 | 406.03.G | Add the following after the first sentence of the second paragraph: “Where possible, maintain the stream flow thru the existing channel, temporary channel, or temporary culvert.” |
| 224 | 406.03.G | Replace the fifth paragraph of this subsection with the following: “The Contractor may use cast-in-place wing walls, headwalls, and aprons, as alternatives to precast wing walls, headwalls, and aprons. Attach cast-in-place wing walls or headwalls as shown on the shop drawings.” |
| 225 | 406.03.G.2 | Change the third sentence of the first paragraph to read: “Before placing the open-graded aggregate 34R, compact the coarse aggregate 6A using at least three passes of a vibrating plate compactor.” |
| 226 | 406.03.G.2 | Change the first sentence of the second paragraph of this subsection to read: "Fill the space between the box culvert joints during placement of box sections with closed-cell rubber extrusion type gaskets in accordance with ASTM C 990." |
| 226 | 406.04.A.9 | Change the sentence to read: “Providing plan modifications including design, additional plan quantities and pay items to accommodate any changes to the precast units as shown on the plans.” |
| 226* | 406.04.A | Add the following paragraph after the last paragraph of the subsection: “The substructure design is specific to the three-sided or arch culvert detailed on the plans. The Contractor must use approved MDOT service vendors qualified in Hydraulics, Geotechnical Engineering Services, and Short and Medium Span Bridges to perform the required design and |

| Page | Subsection | Errata |
|------|------------|--|
| | | plan modifications, as directed by the Engineer, if the Contractor selects a culvert shape different than shown on the plans." |
| 227 | 406.04.B | <p>Add the following new item in the list of items in this subsection:</p> <p>2. Headwalls, wingwalls, aprons, and curtain walls, precast or cast-in-place;</p> <p>Renumber the exist items 2 through 4 in this list to read 3 through 5.</p> <p>Delete existing item numbered 5 and replace with the following:</p> <p>6. Inserts for bars and connection hardware; and</p> <p>Renumber the existing item 6 in this list to read 7.</p> |
| 227 | 406.04.B | <p>Delete the first and second paragraphs following the list of items in this subsection and replace with the following:</p> <p>"The Department will pay separately for cast-in-place concrete, other than for culvert segments, wing walls, and headwalls; excavation; protective coating; providing and placing backfill material; by plan quantity in accordance with subsection 109.01.A."</p> |
| 239 | 501.03.C.6 | <p>The first sentence of this subsection should read "Except as specified in subsection 501.03.C.4, removing HMA surface applies to removing HMA overlying a material designated for removal or that is required to remain in place."</p> |
| 247 | 501.03.O | <p>Change footnote e in Table 501-5 to read:</p> <p>"Flushing severe enough to significantly affect surface friction (Friction Number <35)."</p> |
| 249 | 501.04.H | <p>The first sentence of this subsection should read "The Engineer will measure, and the Department will pay for removing HMA surface, no greater than 12 inches thick, overlying a material designated for removal or that is required to remain in place, as HMA Surface, Rem."</p> <p>The second paragraph of this subsection should read "The Engineer will measure, and the Department will pay for removing HMA surface, greater than 12 inches thick, overlying a material designated for removal or that is required to remain in place, as Pavt, Rem in accordance with subsection 204.04."</p> |
| 257 | 503.03.E | <p>Delete this subsection in its entirety.</p> |
| 265 | 504.03.E.3 | <p>Delete this subsection in its entirety.</p> |
| 269 | 504.04.A | <p>This subsection should read "The unit prices for Micro-Surface, regardless of the type required, include cleaning existing pavement; applying a bond coat; temporary pavement markings; stationing; corrective action; and traffic control to complete corrective action."</p> |

| Page | Subsection | Errata |
|-------------|-------------------|---|
| 299 | 601.04 | In table 601-2 delete the row for Grade P-NC concrete in its entirety. |
| 300 | 601.04 | In table 601-2, the first sentence of footnote b. should read: "Use coarse aggregate 6A, 6AA or 6AAA for Grades P1, P2 and M." In table 601-2, footnote c. should read: "The mix design basis for bulk volume (dry, loose) of course aggregate per unit volume of concrete is 72% for Grade P1; 74% for Grade P2." |
| 308 | 602.03.F | Note c. in Table 602-1 should read "Refer to Section D6 of the Materials Quality Assurance Procedures Manual for inspection procedure." |
| 320 | 602.04.C.3 | The last paragraph in this subsection should read "If the Engineer approves a substitution of a higher concrete grade for a lesser grade (e.g., P1 for P2), the Department will pay for the higher grade of concrete using the original bid and pay items of the lesser grade." |
| 327 | 603.02 | Change the second material in the list to read: "Concrete, Grade P-NC.....603" Change the third material in the list to read: "Base Course Aggregate, 4G, 21AA, 22A.....902" |
| 334 | 603.03.B.10 | Change the last sentence of the second paragraph to read "Apply the required curing compound in two coats, at a rate of at least 1 gallon per 25 square yards for each coat." |
| 342 | 603.04.G.3 | Change "D1" to "W" in two instances in this subsection. |
| 351 | 701.04 | Replace Tables 701-1A and 701-1B with the Table 701-1 below. |
| 362 | 704.03.C | Change the last sentence in the first paragraph of this subsection to read: "The Engineer will consider approval after receiving applicable MDEQ permits for the alternate method." |
| 372 | 705.03.C.1 | Add the following sentence after the first paragraph of this subsection: "Do not drive piles within a radius of 25 feet of newly placed concrete until the concrete attains at least 75 percent of its specified minimum strength." |
| 374 | 705.03.C.2.c | Change the last sentence of the second paragraph to read "Drive test piles to the minimum pile length or practical refusal, whichever is greater". |
| 379 | 705.04 | Change the fifth item down the list to read: "Pile, Galv (Structure No.)" |
| 380 | 705.04 | Change the last item in the list to read: "Pile Driving Equipment, Furn (Structure No.)" |

| Page | Subsection | Errata |
|------|--------------|---|
| 383 | 706.02 | The fourth paragraph following the list of materials should read "Provide AASHTO M 270, Grade 36 steel, meeting the requirements of ASTM A 786, galvanized in accordance with section 707, for expansion joint cover plates. Provide plates at least 3/8 inch thick. Use plates with a slip resistance equal to or greater than those meeting the requirements of ASTM A 786 and must be approved by the Engineer. Provide ASTM F 593 (Type 304) stainless steel, 3/4-inch or 1/2-inch diameter, flathead countersunk screws with 3/4-inch or 1/2-inch diameter inserts for use in expansion joint cover plates." |
| 389 | 706.03.D.4.b | Change the first sentence of the fourth paragraph to read "Design forms, form supports, and attachments to carry dead loads, and resultant horizontal loads due to forming of cantilever overhangs." |
| 390 | 706.03.E.4 | Change the fourth sentence of the first paragraph to read: "Use wire ties to secure all bar intersections for the top mat. Use wire ties to secure all bar intersections for other mats where the product of the length and width of bar intersection spacing exceeds 120 square inches." |
| 391 | 706.03.E.8 | Change the first sentence of the second paragraph of this subsection to read: "Patch sawed or sheared ends and visible defects in accordance with ASTM A 775." |
| 392 | 706.03.E.8 | Change the last sentence of the third paragraph of this subsection to read: "Coat mechanical splices after splice installation in accordance with ASTM A 775 for patching damaged epoxy coating." |
| 394 | 706.03.H.1 | Delete the last paragraph on page 394 and replace it with the following: "Do not cast sidewalk, curb, or barrier pours until the deck concrete attains at least the minimum specified 7-day flexural or compressive strength, and after completion of the 7-day continuous wet cure. The forming of succeeding portions may occur, provided the wet cure is maintained." |
| 406* | 706.03.N.1.b | Add the following to the end of the last paragraph of the subsection: "Do not discontinue wet cure nor cast succeeding portions onto the bridge deck prior to completion of the 7-day two-phase continuous wet cure. Ensure excess or ponding cure water is removed prior to casting of succeeding structure portions." |
| 416 | 707.03.C.1 | Change the title of the subsection from "Shop Plans to read "Shop Drawings". Change the second sentence of this subsection to read: "Do not use design drawings in lieu of shop drawings." |

| Page | Subsection | Errata |
|------|--------------|---|
| 426 | 707.03.C.17 | Change the second sentence in the first paragraph of this subsection to read: "Tap oversized galvanized nuts in accordance with ASTM A 563 or AASHTO M 292 and meet Supplementary Requirement S1 of ASTM A 563 or AASHTO M 292." |
| 430 | 707.03.D.7.b | Delete the first sentence of the last paragraph of this subsection. |
| 430* | 707.03.D.7.b | Change the title of the Table 707-4 to read: "Minimum Bolt Tension for ASTM F 3125 Grade A 325" |
| 430 | 707.03.D.7.b | Change "104,000" to "103,000" in the last row under the column titled Minimum Bolt Tension. |
| 431 | 707.03.D.7.c | Add the following sentence to the end of the first paragraph of this subsection: "If using impact wrenches, provide wrenches sufficient to tighten each bolt in approximately 10 seconds." |
| 431* | 707.03.D.7.c | Change the first sentence of the second paragraph to read: "Do not reuse ASTM F 3125 Grade A 325 bolts and nuts.." |
| 434 | 707.04.A | Change the first sentence of the first paragraph of this subsection to read: "The Engineer will measure structural steel by the calculated weight of metal in the finished structure, excluding filler metal in welding, as shown on the shop drawings or working drawings." |
| 438 | 708.03.A.2 | Change the title of the subsection from "Shop Plans to read "Shop Drawings". Change the first sentence to read: "Submit shop drawings in accordance with subsection 104.02." Change the fourth sentence to read: "Do not start production until the Engineer approves the shop drawings." |
| 441* | 708.03.A.11 | Change the last sentence of the first paragraph to read "Cure concrete at temperatures from 70 °F to 150 °F until concrete attains the release strength shown on the shop drawings". |
| 441 | 708.03.A.11 | Change the fourth sentence of the fourth paragraph to read "Do not exceed a maximum concrete temperature of 150 °F during the curing cycle." |
| 458 | 711.03.A | Change the first sentence in the first paragraph to read: "Shop drawings for structural steel and pipe railings are not required." |
| 460 | 711.04.A | Change the second sentence of the first paragraph to read: |

| Page | Subsection | Errata |
|------|------------|---|
| | | "The unit price for Bridge Barrier Railing includes the cost of placing steel reinforcement, providing and placing concrete, constructing joints, and forming, finishing, curing and protecting the concrete." |
| 461 | 711.04.F | The title of this subsection should read " Reflective Marker, Permanent Barrier. " |
| 467 | 712.03.C | Add the following to the end of the third paragraph of the subsection: "Notify the Engineer of any saw cuts in the top flange. Saw cuts equal to or less than 1/32 inch deep in steel beams must be repaired by grinding, to a surface roughness no greater than 125 micro-inches per inch rms, and tapering to the original surface using a 1:10 slope. Saw cuts in excess of 1/32 inch deep in steel beams require a welded repair to be submitted to the Engineer for approval. Weld in accordance with subsection 707.03.D.8 and provide adequate notice to allow the Engineer to witness the repair work. Inspect and test all saw cut repairs (including grinding repairs) using ultrasonic testing in accordance with 707.03.D.8.c at no additional cost to the Department." |
| 471 | 712.03.J | Add the following to the end of the second paragraph of the subsection: "Select adhesive anchor systems from the Qualified Products List." |
| 471 | 712.03.J.1 | Delete the first paragraph in this subsection and replace it with the following: "Propose complete details of drilling, cleaning, and bonding systems for anchoring reinforcement and submit for the Engineer's approval before use. The minimum embedment depth must be nine times the anchor diameter for threaded rod or bolt and twelve times the anchor diameter for reinforcing bar. Propose a drilling method that does not cut or damage existing reinforcing steel. Prepare at least three proof tests per anchor diameter and type in the same orientation in which they will be installed on the existing structure, on a separate concrete block, in the presence of the Engineer. The Engineer will proof test the proposed systems. The Engineer will base approval of the anchoring system on the following criteria:" |
| 471 | 712.03.J.2 | Change the third sentence of the first paragraph to read: "Use a tension testing device for unconfined testing, in accordance with ASTM E 488." |
| 473 | 712.03.L.2 | Change the first sentence in the second paragraph of this subsection to read: "If using epoxy coated steel reinforcement, epoxy coat mechanical reinforcement splices in accordance with ASTM A 775." |
| 473 | 712.03.L.3 | Delete the existing first sentence in the first paragraph. |
| 473 | 712.03.L.3 | Change the third sentence of the first paragraph to read "Provide two test splices on the largest bar size." |
| 473* | 712.03.L.3 | Change the sentence beginning "Demonstrate to the.... to read: |

| Page | Subsection | Errata |
|------|------------|---|
| | | "Demonstrate to the Engineer that splices have a tensile strength of 125 percent of the bar yield strength and high strength splices have a tensile strength of 150 percent of the bar yield strength." |
| 488 | 713.02 | Add the following as subsection 713.02.C: "C. Structural Steel for Retrofitting and Welded Repairs. Structural steel material used for retrofitting and welded repairs of primary members as defined in subsection 707.01.B must meet longitudinal Charpy V-Notch impact test requirements." |
| 501 | 715.02 | Add the following material reference above the two existing items: "Sealant for Perimeter of Beam Plates713" |
| 508 | 715.03.D.1 | Add the following sentence after the second paragraph of the subsection: "Apply sealant for perimeter of beam plates in accordance with subsection 713.03.F." |
| 515 | 716.03.A | Delete the second paragraph of this subsection in its entirety. Change the last sentence of the last paragraph of this subsection to read: "Provide a primer dry film thickness for the top flange between 4 mils and 10 mils." |
| 519 | 716.04 | Change the second sentence of the first paragraph of this subsection to read: "The unit price for Field Repair of Damaged Coating (Structure No.) includes the costs of making field repairs to the shop applied coating system; prime coat surfaces and exposed surfaces of bolts, nuts, and washers; and repairing stenciling." |
| 521 | 717.04.B | This subsection should read "The unit price for Drain Casting Assembly includes the cost of providing and installing the downspout and, if necessary, the lower bracket to the drain casting." |
| 522 | 718.02 | Change the section number "906" in the third material in the list to read "919." |
| 533 | 718.04 | Delete the following pay item from the list: Temp CasingFoot |
| 533 | 718.04.B.2 | Delete this subsection in its entirety. |
| 533 | 718.04.B.3 | Rename this subsection as follows: "2. Permanent Casing. " |
| 540 | 802.04 | Change "Non reinf" in the last pay item of the list with "Nonreinf". |
| 545* | 803.04.E | Change the second sentence of the second paragraph to read: |

| Page | Subsection | Errata |
|------|------------|--|
| | | "The unit price for Railing for Steps includes the cost of providing, fabricating, installing, and grouting the railing." |
| 560 | 807.04 | Delete the following pay item from the list: Guardrail Buffered EndEach |
| 560 | 807.04.B | Change the fifth paragraph of this subsection to read: "The Engineer will measure Guardrail Salv and Guardrail, Mult, Salv along the face of the rail (one face for multiple beams), including terminals and end shoes." |
| 567 | 808.04.C | Change the first paragraph of this subsection to read: "The Department will not pay separately for protective fence required in accordance with subsection 104.07." |
| 569 | 809.04.A | Change the first sentence to read: "The unit price for Field Office, CI ___ includes the cost of setup, providing access, grading, maintaining, plowing snow, and utility hook-up charges." |
| 570 | 809.04.B | Delete the existing second and third sentences in the first paragraph and replace them with the following: "The unit price for Field Office, Utility Fees includes the cost of monthly usage fees for electricity, gas, telephone service and charges, fuel for the stove, monthly water and sanitary service." |
| 570 | 809.04.B | Change the existing fourth sentence in the first paragraph to read: "The Department will reimburse the Contractor for monthly usage fees for electricity, gas, telephone, water and sanitary charges incurred by the Department." |
| 575 | 810.03.K | Change the subsection to read "K. Drilled Piles for Cantilever and Truss Foundations. Construct drilled piles for cantilever and truss foundations in accordance with section 718." |
| 578 | 810.03.N.2 | Add the following sentence after the first sentence of the second paragraph on this page: "Mark each nut and bolt to reference the required rotation." |
| 584 | 810.04 | Delete the last pay item in the list: Truss Fdn Anchor Bolts, Replace.....Each |
| 585 | 810.04.B.1 | Change the second paragraph to read: "The unit prices for Fdn, Truss Sign Structure Type __, __ inch Dia, Cased and Fdn, Cantilever Sign Structure Type __, __ inch Dia, Cased include the cost of concrete, slurry, steel reinforcement, permanent casings, anchor bolts, excavation, and disposal of excavated material." |

| Page | Subsection | Errata |
|------|------------|--|
| 585 | 810.04.B.2 | Change the second sentence of the first paragraph to read: "The unit prices for Fdn, Truss Sign Structure Type __, __ inch Dia, Uncased and Fdn, Cantilever Sign Structure Type __, __ inch Dia, Uncased include the cost of concrete, slurry, steel reinforcement, temporary casings, anchor bolts, excavation, and disposal of excavated material." |
| 596 | 811.03.G | Delete this subsection in its entirety. |
| 597* | 811.03.H | Rename this subsection as follows: "G. Raised Pavement Marker (RPM) Removal." |
| 597* | 811.04 | Change "Crosshatching" in the last pay item of the list on this page to "Cross Hatching". |
| 598* | 811.04 | Delete the following pay items from the list: Pavt Mrkg, (material), 4 inch, SRSM, (color).....Foot Pavt Mrkg, (material), 4 inch, SRSM, 2 nd Application, (color).....Foot Add the following pay items to the list: "Pavt Mrkg, Polyurea, (legend).....Each Pavt Mrkg, Polyurea, (symbol).....Each" Change the sixth item down the list to read: "Pavt Mrkg, Polyurea, __ inch, Cross Hatching, (color)" Change the eleventh item down the list to read: "Rem Curing Compound, for Longit Mrkg, __ inch.....Foot" |
| 599 | 811.04.B | Delete this subsection in its entirety. |
| 599 | 811.04 | Rename the following subsections as follows: "B. Call Back. C. Pavement Marking Removal. D. Material Deficiency." |
| 602 | 812.03.D | Change the first sentence to read "Provide and maintain traffic control devices meeting the requirements in the ATSSA Quality Guidelines for Work Zone Traffic Control Devices and Features." |
| 603 | 812.03.D.1 | The last sentence on this page should read "Lay the sign behind the guardrail, with the uprights pointing downstream from the traffic, and place the support stands and ballasts close to the guardrail." |
| 604 | 812.03.D.2 | The first sentence of the fourth paragraph should read "Do not use burlap or similar material to cover Department or Local Government owned signs." |
| 604 | 812.03.D.5 | The fifth sentence of the first paragraph should read "Do not mix drums and cones within a traffic channeling sequence." |

| Page | Subsection | Errata |
|-------------|-------------------|---|
| 605 | 812.03.D.6.b | Change the first sentence of the first paragraph to read: "The Department will allow the nighttime use of 42-inch channelizing devices, in the tangent area only, on CPM and pavement marking of any duration where the use of plastic drums restricts proposed lane widths to less than 11 feet, including shy distance." |
| 605 | 812.03.D.7 | Add the following sentence after the first sentence of the first paragraph: "Place a shoulder closure taper in advance of the lighted arrows placed on the shoulders." |
| 607 | 812.03.D.9 | Delete the second paragraph of this subsection and replace with the following: "Link sections together to fully engage the connection between sections. Maintain the barrier with end-attachments engaged and within 2 inches of the alignment shown on the plans." |
| 608 | 812.03.D.10.b | Delete the second sentence of the second paragraph of this subsection beginning with "Install sand module attenuators..." |
| 608 | 812.03.D.10.b | Add the following sentence after the second paragraph of this subsection: "Install impact attenuation devices as shown on the plans, as directed by the Engineer, or both." |
| 609 | 812.03.D.10.e | Delete the second paragraph of this subsection. |
| 613* | 812.03.D.14.a.iii | Change the sentence in this subsection to read "Place a terminal end shoe, in accordance with Standard Plan R-66-Series, and of appropriate type based on existing guardrail, on both blunt guardrail ends." |
| 615 | 812.03.F | The second sentence of the second paragraph of this subsection should read: "The Contractor may use a Type R temporary pavement marking cover, per subsection 812.03.D.12 when authorized by the Engineer." |
| 616 | 812.03.F.2 | The last sentence of the first paragraph should read: "If the removal equipment cannot collect all removal debris, operate a self-propelled sweeper capable of continuously vacuuming up the removal debris immediately behind the removal equipment." |
| 617 | 812.03.G.3 | The first sentence of the second paragraph should read: "Sweep the shoulder and remove debris prior to placing traffic on the shoulder and throughout the time the shoulder is used to maintain traffic." |
| 617 | 812.03.G.4.a | Delete "48 inch by 48 inch" from the first sentence of this subsection. |
| 618* | 812.03.G.7 | The first sentence of the first paragraph should read: "Clean barrier reflectors, plastic drums, 42 inch channelizing devices, tubular markers, signs, barricades, and attached lights in operation on the project to ensure they meet required luminosity." |

| Page | Subsection | Errata |
|------|--------------|--|
| 619 | 812.03.G.8 | The second sentence of the third paragraph from the end of the subsection should read: "Illuminate traffic regulator stations at night per subsection 812.03.H." |
| 621 | 812.03.I.6 | Delete "48 inch by 48 inch" from the second sentence of this subsection. |
| 622* | 812.03.J | The second paragraph should read "Apply one 2-inch wide horizontal stripe of red and white conspicuity tape along at least 50 percent of each side of, and across the full width of the rear of the vehicle or equipment." |
| 622 | 812.04 | Change the second item down the list to read: "Traf Regulator Control" Change the sixth item down the list to read: "Sign Cover, Type I" |
| 626 | 812.04.I | Change the reference "812.04.E" in the first sentence to "812.04.D". |
| 628 | 812.04.M.4 | Add the following as the first sentence of this subsection: "The Engineer will not measure a temporary barrier ending move as Conc Barrier Ending, Temp, Relocated if it involves work defined in subsection 812.04.M.3." |
| 629 | 812.04.N.1 | Change the reference "811.04.D" in the second paragraph of this subsection to read "811.04.C". |
| 630 | 812.04.S | Change the first sentence to read: "The Department will not make additional payments for traffic regulating, signing, arrow boards, and lighting systems for traffic regulator stations operated at night due to a temporary PTS system failure." |
| 634 | 813.03.C.3 | Change the reference "903.07.A" in the paragraph of this subsection to read "907.07.B". |
| 646 | 815.04 | Change the first, third and fourth pay items in the list to read: "Site Preparation, Max (dollar) Lump Sum Watering and Cultivating, First Season, Min (dollar)..... Lump Sum Watering and Cultivating, Second Season, Min (dollar) Lump Sum" |
| 646 | 815.04.C.1 | Change the following pay item reading: "Watering and Cultivating, First Season, Min. (dollar)" to read "Watering and Cultivating, First Season, Min (dollar)" at two locations throughout the subsection. |
| 646 | 815.04.C.1.b | Delete this subsection in its entirety. |
| 646 | 815.04.C.1.c | Rename this subsection to read: "b. Removal and disposal of unacceptable plants." |
| 646 | 815.04.C.2 | Change the following pay item reading: "Watering and Cultivating, Second Season, Min. (dollar)" to read "Watering and Cultivating, |

| Page | Subsection | Errata |
|------|--------------|---|
| | | Second Season, Min (dollar)" at three locations throughout the subsection. |
| 647 | 815.04.C.2 | Change the last paragraph of this subsection to read: "For each unacceptable plant identified, the Engineer will calculate a 50 percent reduction in the unit price for the relevant (Botanical Name) pay item, and will process a negative assessment for each unacceptable plant for that amount." |
| 650 | 816.03.B | Delete the first paragraph of this subsection and replace with the following: "Conduct soil tests when called for in the contract or when directed by the Engineer. Provide soils tests results to the Engineer when testing is required. Provide and place fertilizer as indicated below and as indicated in the soils tests, if required." |
| 650 | 816.03.B.1 | Change the sentence to read: "For Class A fertilizer, evenly apply 176 pounds of chemical fertilizer nutrient per acre on a prepared seed bed." |
| 650 | 816.03.B.2 | Change the sentence to read: "For Class B fertilizer, evenly apply 120 pounds of chemical fertilizer nutrient per acre on a prepared seed bed." |
| 650* | 816.03.B.3 | Change the sentence to read: "For Class C fertilizer, evenly apply 80 pounds of chemical fertilizer nutrient per acre on established turf." |
| 663* | 819.01 | Delete the first paragraph in the subsection and replace it with the following: "This work consists of providing operating electrical and lighting units; removing, salvaging, or disposing of existing electrical and lighting components; excavating, backfilling, restoring the site in accordance with section 816; and disposing of waste excavated materials. Complete this work in accordance with this section, section 820, and the contract and to the requirements of the NEC, the National Electrical Safety Code, and the MDLARA for those items not identified in the contract." Change the third sentence of the second paragraph in this subsection to read: "Contact the MDLARA for electrical service inspection and pay the applicable fees." |
| 671 | 819.03.F.1 | Change the paragraph to read: "Install light standard foundations as shown on the plans and the standard plans, as applicable." |
| 673 | 819.03.G.4.b | Change the last sentence of the first paragraph to read: "Tighten the anchor bolts to a snug tight condition as described in the third paragraph of subsection 810.03.N.2 ensuring the lock washer is completely compressed." |

| Page | Subsection | Errata |
|------|--------------|--|
| 673 | 819.03.G.4.b | Delete the first two sentences of the second paragraph and replace with the following: "Tighten bolts connecting the pole to the frangible base to a snug tight condition. Snug tight is the tightness attained by a few impacts of an impact wrench, or the full effort of a person using an ordinary spud wrench. The lock washers must be fully compressed." |
| 678 | 819.04 | Change the ninth pay item in the list to read: "DB Cable, 600V, 1/C# (size)..... Foot" |
| 678* | 819.04 | Delete the last item in the list on this page reading: "DB Cable, in Conduit, 600 Volt, (number) 1/C# (size) Foot" |
| 679 | 819.04 | Change the first pay item in the list to read: "DB Cable, in Conduit, 600V, 1/C# (size)..... Foot" |
| 679 | 819.04 | Change the sixth pay item in the list to read: "Cable, P.J., 600V, 1, (size) Foot" |
| 680 | 819.04 | Change the first paragraph to read: "Unless otherwise required, the unit prices for the pay items listed in this subsection include the cost of excavation, granular material, backfill, and disposal of waste excavated material. If the contract does not include pay items for restoring the site in kind in accordance with section 816, the Department will consider the cost of restoration included in the pay items listed in this subsection." |
| 680 | 819.04.A | Add the following paragraph after the first paragraph of the subsection. "The unit prices for Conduit, Rem include the cost of removing the type, number, and size of conduit shown on the plans." Change the third paragraph of the subsection to read: "The unit prices for Conduit, (type), __ inch and Conduit, DB, (number), __ inch include the cost of installing the type, number, and size of conduit shown on the plans, and installing marking tape." |
| 681 | 819.04.B | Change the last paragraph of the subsection to read: "The unit price for DB Cable, in Conduit, Rem includes the cost of removing all cables from the existing conduit measured per lineal foot of conduit." |
| 681 | 819.04.C | Change the first paragraph of the subsection to read: "The unit prices for Cable, Rem and Cable, (type), Rem include the cost of dead ending, circuit cutting, installing guying, work required to leave circuits operable, and disposing of the removed cables, wire, hardware, and other appurtenances." |
| 681 | 819.04.D | Change the first paragraph of the subsection to read: "The unit price for Cable, Pole, (type), Disman includes the cost of dismantling and off-site disposal of the following:" |

| Page | Subsection | Errata |
|------|------------|---|
| 685 | 820.01.D | Change the sentence to read: "Excavate, backfill, restore the site in kind in accordance with section 816, and dispose of excess or unsuitable material;" |
| 688 | 820.03.C | Change the seventh paragraph of this subsection to read: "Tighten top anchor bolt nuts, snug, in accordance with the first four paragraphs of subsection 810.03.N.2, except beeswax will not be required." |
| 696 | 820.04 | Add the following pay items to the list: "Pedestal, Pushbutton, Alum.....Each Pedestal, Pushbutton, Rem.....Each" |
| 697 | 820.04.A.2 | Change the sentence to read: "If the contract does not include pay items for restoring the site in kind in accordance with section 816, the Department will consider the cost of restoration included in the pay items listed in this subsection." |
| 698 | 820.04.B | Delete the second paragraph of this subsection found on this page. |
| 698 | 820.04.C | Change " Fdns " to read " Fdn " in four instances in this subsection. |
| 701 | 820.04.J.3 | Change the sentence to read: "Installing wires in the saw slots and to the handholes;" |
| 701. | 820.04.J | Add the following as a new subsection: "7. A 3/4 inch minimum flexible conduit (non-metallic and rated for underground use) from the pavement to the handhole." |
| 706 | 821.01.B | Change the website address listed after the second paragraph on this page to read: <u>"http://www.ngs.noaa.gov/heightmod/GuidelinesPublications.shtml"</u> |
| 711 | 822.03.B | Change the second paragraph to read: "If corrugations are required on concrete shoulders and the method of installation is not shown on the plans or directed by the Engineer, construct corrugations by grinding, or cutting." |
| 718 | 823.03.U | Change "MDNRE" to "MDEQ" in four instances in this subsection. |
| 720 | 823.04 | Change the pay item seventh from the bottom of the list to read: "Water Shutoff, Adj, Temp, Case ___" |
| 730 | 824.03.Q | Change the third sentence of the fourth paragraph to read: "Ensure placement of monumentation in accordance with section 821." |
| 730 | 824.03.Q | Change the first sentence of the last paragraph to read: "The Department will not pay for work dependent on lost or destroyed stakes until the Contractor replaces the stakes." |

| Page | Subsection | Errata |
|------|------------------|---|
| 732 | 824.04 | Change the first sentence of the first paragraph following the list of pay items to read: "If the Engineer determines the Contractor will perform staking as extra work, the Department will pay for staking in accordance with section 103." |
| 733 | 824.04 | Change the left column header in Table 824-2 to read: "Percent of Original Contract Amount Earned" |
| 739 | 902.02 | Change the last aggregate testing description to read: "Determining Specific Gravity and Absorption of Fine Aggregates.....MTM 321" |
| 742 | 902.03.C.1.a | Change the sentence to read: "Coarse aggregate includes all aggregate particles greater than or retained on the 3/4-inch sieve." |
| 742 | 902.03.C.2.a | Change the sentence to read: "Intermediate aggregate includes all aggregate particles passing the 3/4-inch sieve through those retained on the No. 4 sieve." |
| 742 | 902.03.C.2.b.iii | Change the sentence to read as follows: "Maximum Loss by Washing per MTM 108 of 3.0 percent". |
| 744 | 902.07 | Delete the fourth paragraph of the subsection and replace it with the following: "The Engineer will only allow the use of granular material produced from crushed portland cement concrete for embankment and as trench backfill for non-metallic culvert and sewer pipes without associated underdrains. However, granular material produced from crushed portland cement concrete is not permitted as swamp backfill, nor within the top 3 feet below subgrade regardless of the application." |
| 746* | 902.11 | Change the Item of Work by Section Number column in Table 902-1 for the 6AA row to read: "406, 601, 602, 706, 708, 806". Change the Item of Work by Section Number column in Table 902-1 for the 6A row to read: "206, 401, 402, 406, 601, 602, 603, 706, 806". Change the Item of Work by Section Number column in Table 902-1 for the 34R row to read: "401, 404, 406". |
| 751* | 902.11 | Replace Table 902-6 with the Table 902-6 below. |
| 751 | Table 902-7 | Under the Material column in the fourth row change the "FA2" to read "2FA". |
| 751 | Table 902-7 | Under the Material column in the fifth row change the "FA3" to read "3FA". |

| Page | Subsection | Errata |
|------|-------------|---|
| 752 | Table 902-8 | Under the Material column in the fourth row change the "FA2" to read "2FA". |
| 752 | Table 902-8 | Under the Material column in the fifth row change the "FA3" to read "3FA". |
| 761 | Table 904-2 | Delete the footnote f and any other reference to footnote f from the table. |
| 767 | 905.03 | Change the first sentence of the first paragraph to read: "Deformed bars, must meet the requirements of ASTM A 706, ASTM A 615, or ASTM A 996 (Type R or Type A only) for Grade 60 steel bars, unless otherwise required". |
| 767* | 905.03 | Change the first sentence of the second paragraph to read: "Unless otherwise specified, spiral reinforcement must meet the requirements of plain or deformed Grade 40 steel bars of ASTM A 615, ASTM A 996 (Type A), or the requirements of cold-drawn wire of ASTM A 1064". |
| 767 | 905.03 | Change the first sentence of the third paragraph to read: "Bar reinforcement for prestressed concrete beams must meet the requirements of ASTM A 996 (Type R) for Grade 60 steel bars, except the Engineer will allow bar reinforcement that meets the requirements of ASTM A 615 or ASTM A 996 (Type A) for Grade 40 steel bars for stirrups in prestressed concrete beams". |
| 768 | 905.03.C | Change the first sentence in the subsection to read: "Epoxy coated steel reinforcement, if required, must be coated in accordance with ASTM A 775, with the following exceptions and additions." |
| 768 | 905.03.C.3 | Change the first sentence of this subsection to read: "Include written certification that the coated reinforcing bars were cleaned, coated, and tested in accordance with ASTM A 775 with the coating applicator." |
| 768 | 905.05 | Change the first sentence of the first paragraph to read: "Deformed steel bars must meet the requirements of ASTM A 706 or the requirements for Grade 40, Grade 50, or Grade 60 of ASTM A 615 or ASTM A 996 (Type R or Type A only)". |
| 768 | 905.06 | Delete this subsection in its entirety and replace it with the following: "Deformed wire fabric for prestressed concrete and fabric for concrete pavement reinforcement must meet the requirements of ASTM A 1064 and fabricated as required." |
| 772* | 906.07 | Change the first paragraph to read: "High-strength bolt fasteners for structural joints must meet the requirements of ASTM F 3125 Grade A 325 Type 1 bolts. High-strength nuts for structural joints must meet the requirements of ASTM A 563 |

| Page | Subsection | Errata |
|------|--------------|--|
| | | Grade DH or AASHTO M 292 Grade 2H. High-strength washers for structural joints must meet the requirements of ASTM F 436 Type 1 for circular, beveled, clipped circular, and clipped beveled washers." |
| | | Change the second sentence of the second paragraph of this subsection to read: "Galvanized nuts must be tapped oversize in accordance with ASTM A 563 and meet Supplementary Requirements S1, Lubricant and Rotational Capacity Test for Coated Nuts and S2, Lubricant Dye." |
| 777* | 907.03.D.2.a | Change the first sentence of the second paragraph to read: "Angle sections must be nominal 2½ inch by 2½ inch by ¼ inch." |
| 777* | 907.03.D.2.b | Change the first sentence of the first paragraph to read: "Angle section braces must be nominal 1¾ inch by 1¾ inch by ¼ inch or nominal 2 inch by 2 inch ³ / ₁₆ inch." |
| 782 | 908.04 | Change the first sentence of the first paragraph of this subsection to read: "Steel castings for steel construction must meet the requirements of ASTM A 148 for Grade 60/90 carbon steel castings, as shown on the plans, unless the Engineer approves an alternate in writing." |
| 783* | 908.09.A | Change the title of this subsection and the first sentence to read "A. Base Plates, Angle, and Non-Tubular Post Elements. Galvanized base plates, angle, rail splice elements, and non-tubular post elements must meet the requirements of ASTM A 36 and ASTM A 123". |
| 783* | 908.09.B | Change the title of this subsection and the first sentence to read "B. Rail Elements and Tubular Post Elements. Rail elements and tubular post elements must meet the requirements of ASTM A 500, for Grade B and subsection 908.09.B and be galvanized in accordance with ASTM A 123". |
| 784* | 908.09.C | Change this subsection to read: "C. Hardware. Railing anchor studs must meet the requirements of ASTM A 449 Type 1. Heavy hex nuts must meet the requirements of ASTM A 563. Bolts, used as rail fasteners, must meet the requirements of ASTM F 3125 Grade A 325, Type 1. Where called for, round head bolts must meet the requirements of ASTM A 449 Type 1. The material for the railing hand hole screws must meet the requirements of ASTM A 276, Type 304. All nuts must meet the requirements of ASTM A 563 Grade DH or AASHTO M 292 Grade 2H. All flat washers must meet the requirements of ASTM F 436. Lock washers must be steel, regular, helical spring washers meeting the requirements of ANSI B18.21.1 - 1972. Bolts, nuts, washers and other hardware must be hot-dip galvanized in accordance with AASHTO M 232. Galvanized nuts must be tapped oversize in accordance with ASTM A 563, and meet |

| Page | Subsection | Errata |
|------|------------|--|
| | | Supplementary Requirements S1, Lubricant and Rotational Capacity Test for Coated Nuts, and S2, Lubricant Dye." |
| 784 | 908.11.A | Change the first sentence of the first paragraph to read: "Steel beam sections, backup elements, terminal end shoes, and special end shoes must meet the requirements of AASHTO M 180, for Class A guardrail." |
| 785* | 908.11.B | Change the second paragraph to read: "Bolts, nuts, and round washers for guardrail, other than at bridge barrier railings, must meet the requirements of ASTM A 307 (Grade A), ASTM A 563 (Grade A with Supplementary Requirements S1 of ASTM A 563), and ASTM F 436, respectively." Change the third paragraph to read: "Washers, other than round washers, for guardrail must meet the requirements for circular washers in ASTM F 436 except that the dimensions must be as shown on the plans." Change the fifth paragraph to read: "Bolts, nuts, and washers for connections at bridge barrier railings must conform to ASTM F 3125 Grade A 325 Type 1 galvanized high-strength structural bolts with suitable nuts and hardened washers." |
| 787 | 908.14.B | Add the following sentence to the end of the third paragraph of this subsection: "Exposed threaded ends of anchor bolts must be galvanized a minimum of 20 inches." Change the sixth paragraph in this subsection to read: "Provide washers meeting the requirements of ASTM F 436 for circular washers." |
| 787 | 908.14.B | Change the second sentence of the fourth paragraph to read "After coating, the maximum limit of pitch and major diameter for bolts with a diameter no greater than 1 inch may exceed the Class 2A limit by no greater than 0.021 inch, and by no greater than 0.031 inch for bolts greater than 1 inch in diameter". |
| 787* | 908.14.C | Change the first paragraph to read "Provide either four or six high strength anchor bolts per the contract plans, meeting the mechanical requirements of ASTM F 1554, for Grade 105, with each standard. Anchor bolts for traffic signal strain poles must meet the requirements of subsection 908.14.B with the following exceptions and additions:" |
| 789 | 909.03 | Change the second sentence of the second paragraph to read: "As an alternative to the AASHTO M 36 requirements for metal pipe, the Contractor may use gasket material meeting the low temperature flexibility and elevated temperature flow test requirements of ASTM C |

| Page | Subsection | Errata |
|------|-------------|--|
| | | 990, excluding the requirements for softening point, flashpoint and fire point." |
| 793 | 909.06 | Change the first sentence of the second paragraph of this subsection to read: "Provide Corrugated Polyvinyl Chloride Pipe (CPV) and required fittings meeting the requirements of AASHTO M 304." |
| 793* | 909.05.D | Change the second sentence of the paragraph to read "Provide a continuous welded joint to create a watertight casing that is capable of withstanding handling and installation stresses. Perform field welding by the SMAW process using E7018 electrodes." |
| 794* | 909.08.A | Change the first sentence to read: "Provide bridge deck downspouts of PE pipe meeting the requirements of ASTM F 714, PE 4710, DR 26." |
| 804 | Table 909-9 | In the note area at the bottom of the table change the designation of the second note from "c." to "b." |
| 811 | 910.04 | Add the following sentence to the end of this subsection: "Fabricate silt fence according to subsection 916.02." |
| 814 | Table 911-1 | In the 4 th row of the 5 rows in the table change the Property listed as "Total Organic Content (TOC)" to read "Total Organic Carbon (TOC)". |
| 829* | 912.08.K | Replace Table 912-10 with the Table 912-10 below. |
| 833* | 913.03.B | Change the first sentence of the first paragraph to read: "Clay brick, to construct manholes, catch basins, and similar structures, must meet the requirements of ASTM C 32, for Grade MS." |
| 837* | 914.04 | Add the following as subsection 914.04.C: "C. Lubricant-Adhesive for Neoprene Joint Seals. The lubricant-adhesive must be a single-component moisture-curing polyurethane and aromatic hydrocarbon solvent mixture meeting ASTM D 2835, Type I. Ship in containers plainly marked with the lot or batch number of the material and date of manufacture. Store at temperatures between 58 and 80°F. Do not exceed 12 months shelf-life prior to use." |
| 840 | 914.08 | Change the first sentence of the second paragraph to read: "Straight tie bars for end-of-pour joints must consist of bars of the diameter and length shown on the plans meeting the requirements of ASTM A 615, ASTM A 706, or ASTM A 996 (Type R or Type A only)". |
| 840* | 914.09.A | Change the first sentence of the first paragraph to read: "Straight tie bars for longitudinal pavement joints must consist of bars of the diameter and length shown on the plans meeting the requirements of ASTM A 615, ASTM A 706, or ASTM A 996 (Type R or Type A only)". |

| Page | Subsection | Errata |
|------|------------|--|
| 840 | 914.09.B | Change the first sentence of the first paragraph to read: "Bent tie bars for bulkhead joints must consist of bars of the diameter and length shown on the plans." |
| 841 | 914.12 | In the first sentence of this subsection change "AASHTO Division II" to read "AASHTO LRFD Bridge Construction Specifications". |
| 841* | 914.13 | In the first sentence of this subsection change "ASTM D 1248, for Type III, Class B" to read "ASTM D 4976, Group 2, Class 4, Grade 4". |
| 844 | 916.01.A | Change the first sentence to read: "Cobblestone must consist of rounded or semi-rounded rock fragments with an average dimension from 3 inches to 10 inches." |
| 845 | 916.01.D.1 | Change the second sentence to read: "Checkdams for ditch grades 2 percent or greater must be constructed using cobblestone or broken concrete ranging from 3 inches to 10 inches in size." |
| 851* | 917.10.B.1 | Delete the paragraph and replace it with the following: "1. Class A. Provide and apply Class A chemical nutrient fertilizer either according to MSU Soil Testing Lab Recommendations for Phosphorus Applications to Turfgrass, except the maximum single application rate of nutrient will be 48 pounds per acre, when soil tests are required or as indicated in subsections 917.10.B.1.a and 917.10.B.1.b." |
| 851 | 917.10.B.1 | Add the MSU Soil Testing Lab Recommendations for Phosphorus Applications to Turfgrass, found below, after the first paragraph of this subsection. |
| 853 | 917.15.B.1 | Change the second sentence of the subsection to read: "The net must meet the requirements of subsection 917.15.D and be capable of reinforcing the blanket to prevent damage during shipping, handling, and installation." |
| 857 | 918.01 | Add the following two paragraphs following the first paragraph of this subsection: "Wall thickness and outside diameter dimensions must conform to ASTM D 1785 for smooth-wall schedule 40 and 80 PVC conduit material. The Department will allow no more than 3 percent deviation from the minimum wall thickness specified. Wall thickness range must be within 12 percent in accordance with ASTM D 3035 for smooth-wall coilable schedule 40 and 80 PE conduit." |
| 858 | 918.01.E | Delete the first three sentences of the second paragraph shown on page 858. |
| 863 | 918.06.F.1 | Delete the third paragraph in this subsection in its entirety and replace it with the following: |

| Page | Subsection | Errata |
|-------------|-------------------|---|
| | | "Provide smooth or deformed welded wire fabric in accordance with ASTM A 1064." |
| 864 | 918.07.C | Change the first sentence of the first paragraph to read: "Provide anchor bolts, nuts, and washers meeting the requirements of subsection 908.14.A and subsection 908.14.B." |
| 864 | 918.07.C | Delete the second sentence of the second paragraph. |
| 864 | 918.07.C | Change the third sentence to read: "Provide anchor bolts threaded 4 inches beyond the anchor bolt projection shown on the plans." |
| 867 | 918.08.C | Change the last sentence of the first paragraph on this page to read: "Galvanize bolts, nuts, washers, and lock washers as specified in subsection 908.14.B." |
| 867 | 918.08.C | Change the last sentence of the subsection to read: "Provide each frangible base with manufacturer access covers as shown on the plans." |
| 867* | 918.08.D | Delete this subsection in its entirety and replace with the following: "Provide galvanized anchor bolts, studs, nuts, couplings, and washers in accordance with subsection 908.14." |
| 879 | 918.10.J | Change the third sentence of the second paragraph of this subsection to read: "Provide anchor bolts and associated nuts, washers, and hardware meeting the requirements of subsection 908.14." |
| 887 | 919.06 | Change the second paragraph to read: "Shims must be fabricated from brass shim stock or brass strip meeting the requirements of ASTM B 36, for copper alloy UNS No. C26000, half-hard rolled temper, or fabricated from galvanized sheeting meeting the requirements of ASTM A 653, for Coating Designation G 90." |
| 887 | 919.07.C | Change the sentence to read: "Galvanized high-strength steel bolts, nuts, and washers for connecting arm connection flanges must meet the requirements of subsection 906.07." |
| 903 | 921.03.D | Delete the last three sentences of the first paragraph of this subsection. |
| 914 | 921.05.D | Change the first sentence of this subsection to read: "Provide anchor bolts meeting the requirements of subsection 908.14.C, including elongation and reduction of area requirements." |
| 916 | 921.07 | Change the first sentence of the first paragraph to read: "Provide LED case signs internally illuminated by LEDs and changeable message case signs internally illuminated with LED light sources." |

| Page | Subsection | Errata |
|------|----------------|---|
| 936 | 922.04.B | In the first sentence of the first paragraph change the "R-52" to "R-126". |
| 936 | 922.04.B | Add the following to the end of the first paragraph: "Hardware used to connect the end section to the barrier must meet the requirements of NCHRP 350 or MASH (Test Level 3 or higher)." |
| 936 | 922.04.B | In the first sentence of the second paragraph delete "R-52". |
| 936 | 922.04.B | Change the fourth paragraph of this subsection to read as follows: For all endings requiring impact attenuators provide a NCHRP-350 Test Level 3 or MASH Test Level 3 approved impact attenuation system, unless otherwise approved by the Engineer. |
| 953* | Pay Item Index | Delete the following pay item reading: "DB Cable, in Conduit, 600 Volt, (number) 1/C# (size)678 819" |
| 957 | Pay Item Index | Delete the following pay item from the list: Guardrail Buffered End560 807 |
| 960 | Pay Item Index | Change the following pay item to read: "Mobilization, Max (dollar)107 150" |
| 961 | Pay item Index | Delete the following pay items from the list: Pavt Mrkg, (material), 4 inch, SRSM, (color).....598.....811 Pavt Mrkg, (material), 4 inch, SRSM, 2 nd Application, (color).....598.....811 |
| 961 | Pay Item Index | Change the following pay items in the list to read: Pavt Mrkg, Ovly Cold Plastic, 12 inch, Cross Hatching, (color) Pavt Mrkg, Polyurea, __ inch, Cross Hatching, (color) Add the following pay items to the list: "Pavt Mrkg, Polyurea, (legend).....598.....811 Pavt Mrkg, Polyurea, (symbol).....598.....811 Pedestal, Pushbutton, Alum.....696.....820 Pedestal, Pushbutton, Rem.....696.....820" |
| 962 | Pay Item Index | Change the following pay items in the list to read: "Pile Driving Equipment, Furn (Structure No.) Pile, Galv (Structure No.)" |
| 963 | Pay Item Index | Change the following pay item to read: "Rem Curing Compound, for Longit Mrkg, __ inch598 811" |
| 964 | Pay Item Index | Change the following pay item to read: "Sewer, CI __, __ inch, Jacked in Place200 402" "Sign Cover, Type I622 812" |
| 965* | Pay Item Index | Change the following pay item in the list to read: |

| Page | Subsection | Errata | | |
|-------------|-------------------|--|------------|-------------|
| | | “Steel Casing Pipe, __ inch, Tr Det __ Site Preparation, Max (dollar) | 646 | 815” |
| 966 | Pay Item Index | Delete the following pay item form the list; Temp Casing..... | 533..... | 718 |
| 967* | Pay Item Index | Delete the following pay item from the list; Truss Fdn Anchor Bolts, Replace..... | 584..... | 810 |
| 967 | Pay Item Index | Change the following pay item in the list to read: “Traf Regulator Control” | | |
| 968* | Pay item Index | Change the following pay item in the list to read: “Water Shutoff, Adj, Temp, Case __ Watering and Cultivating, First Season, Min (dollar)..... Watering and Cultivating, Second Season, Min (dollar) | 646 646 | 815 815” |
| 993 | General Index | Change “Shop Plans (see Plans and Working Drawings)” to read “Shop Drawings (see Plans and Working Drawings)”. | | |

| Table 701-1 Concrete Structure Mixtures | | | | | | | | | | | |
|---|---|------------------------------|------------------------------------|---------------------------------|--|----------------------------------|----------------|--------|--------------------------------|-------------------|-------|
| Concrete Grade (e,h) | Section Number Reference (i) | Cement Content per cyd (b,c) | Slump (inches) | | | Minimum Strength of Concrete (f) | | | | | |
| | | | Type A, D Admixture | Type MR, F, or G Admixtures (g) | | | Flexural (psi) | | | Compressive (psi) | |
| | | | | Before Admixture | After Admixture (Type MR) | After Admixture (Type F or G) | 7 Day | 14 Day | 28 Day (Class Design Strength) | | 7 Day |
| D (a) | 706, 711, 712 | 658 (d) | 0 - 3 | 0 - 3 | 0 - 7 | 625 | 700 | 725 | 3,200 | 4,000 | 4,500 |
| S1 | 705 | 611 | 3 - 5 | 3 - 6 | 3 - 7 | 600 | 650 | 700 | 3,000 | 3,500 | 4,000 |
| T | 705, 706 | 611 | 3 - 7 | 3 - 7 | 3 - 8 | 550 | 600 | 650 | 2,600 | 3,000 | 3,500 |
| S2 (a) | 401, 705, 706, 712, 713, 801, 802, 803, 810 | 564 526 (d) | 0 - 3 | 0 - 6 | 0 - 7 | 550 | 600 | 650 | 2,600 | 3,000 | 3,500 |
| S3 | 402, 403, 803, 804, 806 | 517 489 (d) | 0 - 3 | 0 - 6 | 0 - 7 | 500 | 550 | 600 | 2,200 | 2,600 | 3,000 |
| <p>a. Unless otherwise required, use Coarse Aggregate 6AA or 17A for exposed structural concrete in bridges, retaining walls, and pump stations.</p> <p>b. Do not place concrete mixtures containing supplemental cementitious materials unless the local average minimum temperature for the next 10 consecutive days is forecast to be above 40 °F. Adjustments to the time required for opening to construction or vehicular traffic may be necessary. Cold weather protection may be required, as described in the quality control plan. The restriction does not apply to Grade S1 concrete in foundation piling below ground level or Grade T concrete in tremie construction.</p> <p>c. Type III cement is not permitted.</p> <p>d. Use admixture quantities specified by the Qualified Products Lists to reduce mixing water. Admixture use is required for Grade D, Grade S2, and Grade S3, concrete with a reduced cement content. Use a water-reducing retarding admixture at the required dosage for Grade D concrete to provide the setting retardation required. When the maximum air temperature is not forecast to exceed 60 °F for the day, the Contractor may use a water-reducing admixture or a water-reducing retarding admixture. Ensure Grade D concrete in concrete diaphragms contains a water-reducing admixture, or a water-reducing retarding admixture. For night casting, the Contractor may use a water-reducing admixture in lieu of water-reducing retarding admixture, provided that the concrete can be placed and finished prior to initial set.</p> <p>e. The mix design basis for bulk volume (dry, loose) of coarse aggregate per unit volume of concrete is 68% for Grade S1, and 70% for Grade D, Grade S2, Grade T, and Grade S3.</p> <p>f. The Contractor may use flexural strength to determine form removal. Use compressive strength for acceptance in other situations.</p> <p>g. MR = Mid-range.</p> <p>h. The Engineer will allow the use of an optimized aggregate gradation as specified in section 604.</p> <p>i. Section Number Reference:</p> | | | | | | | | | | | |
| 401 | Culverts | 711 | Bridge Railings | 803 | Concrete Sidewalk, Sidewalk Ramps, and Steps | | | | | | |
| 402 | Storm Sewers | 712 | Bridge Rehabilitation-Concrete | 804 | Concrete Barriers and Glare Screens | | | | | | |
| 403 | Drainage Structures | 713 | Bridge Rehabilitation-Steel | 806 | Bicycle Paths | | | | | | |
| 705 | Foundation Piling | 801 | Concrete Driveways | 810 | Permanent Traffic Signs and Supports | | | | | | |
| 706 | Structural Concrete Construction | 802 | Concrete Curb, Gutter and Dividers | | | | | | | | |

An asterisk (*) indicates an entry which has been revised from an earlier version of this Supplemental Specification.

**Table 902-6
Superpave Final Aggregate Blend Physical Requirements**

| Est. Traffic (million ESAL) | Mix Type | Percent Crushed Minimum Criteria | | Fine Aggregate Angularity Minimum Criteria | | % Sand Equivalent Minimum Criteria | | Los Angeles Abrasion % Loss Maximum Criteria | | % Soft Particles Maximum Criteria (b) | | % Flat and Elongated Particles Maximum Criteria (c) | |
|-----------------------------------|-------------|-------------------------------------|----------------|--|----------------|---------------------------------------|----------------|--|----------------|---|----------------|--|----------------|
| | | Top & Leveling Courses | Base Course | Top & Leveling Courses | Base Course | Top & Leveling Courses | Base Course | Top & Leveling Courses | Base Course | Top & Leveling Courses | Base Course | Top & Leveling Courses | Base Course |
| < 0.3 | LVSP | 55/— | — | — | — | 40 | 40 | 45 | 45 | 10 | 10 | — | — |
| < 0.3 | E03 | 55/— | — | — | — | 40 | 40 | 45 | 45 | 10 | 10 | — | — |
| ≥0.3 -<1.0 | E1 | 65/— | — | 40 | — | 40 | 40 | 40 | 45 | 10 | 10 | — | — |
| ≥1.0 - < 3 | E3 | 75/— | 50/— | 40(a) | 40(a) | 40 | 40 | 35 | 40 | 5 | 5 | 10 | 10 |
| ≥3 - <10 | E10 | 85/80 | 60/— | 45 | 40 | 45 | 45 | 35 | 40 | 5 | 5 | 10 | 10 |
| ≥10 - <30 | E30 | 95/90 | 80/75 | 45 | 40 | 45 | 45 | 35 | 35 | 3 | 4.5 | 10 | 10 |
| ≥30 - <100 | E50 | 100/100 | 95/90 | 45 | 45 | 50 | 50 | 35 | 35 | 3 | 4.5 | 10 | 10 |

(a) For an E3 mixture type that enters the restricted zone as defined in Table 902-5, the minimum is 43. If these criteria are satisfied, acceptance criteria and associated incentive/disincentive or pay adjustment tied to this gradation restricted zone requirement included in contract, do not apply. Otherwise, final gradation blend must be outside of the restricted zone.

(b) Soft particles maximum is the sum of the shale, siltstone, ochre, coal, clay-ironstone and particles that are structurally weak or are non-durable in service.

(c) Maximum by weight with a 1 to 5 aspect ratio.

Note: "85/80" denotes that 85 percent of the coarse aggregate has one fractured face and 80 percent has at least two fractured faces.

An asterisk (*) indicates an entry which has been revised from an earlier version of this Supplemental Specification.

| Table 912-10 Minimum Retention Requirements | | | | |
|--|--|-------------------|--|--------------------------|
| Preservative | Minimum Retention, (pcf) | | | AWPA Standard |
| | Guardrail Posts | Sign Posts | Blocks | |
| Pentachlorophenol | 0.60 | 0.50 | 0.40 | A6 |
| CCA, ACZA | 0.60 | 0.50 | 0.40 | A11 |
| ACQ (a) | 0.60 | Not Allowed | 0.40 | A11 |
| CA-B (a) | 0.31 | Not Allowed | 0.21 | A11 |
| CA-A (a) | 0.31 | Not Allowed | 0.15 | A11 |
| Other Waterborne preservatives | AWPA Commodity Specification A, Table 3.0, Use Category 4B | Not Allowed | AWPA Commodity Specification A, Table 3.0, Use Category 4A | A11 |
| a. Non-Metallic washers or spacers are required for timber and lumber treated with ACQ or CA placed in direct contact with aluminum. Do not use with sign posts. | | | | |

MSU Soil Testing Lab Recommendations for Phosphorus Applications to Turfgrass
3/8/2012

| | | Sand based rootzone establishment | Golf greens and tees est. or mature; Kentucky bluegrass or perennial ryegrass athletic fields est. or mature; sand based rootzone mature | Lawns, golf course fairways; establishment or mature | Establishment without soil test |
|--|------------------------------------|---|--|---|---|
| Bray P1, Mehlich 3 Soil Test Value (ppm): pH<7.4 | Olsen Soil Test Value (ppm) pH>7.4 | Recommendation (lbs. P ₂ O ₅ /1000 ft. ²) | Recommendation (lbs. P ₂ O ₅ /1000 ft. ²) | Recommendation (lbs. P ₂ O ₅ /1000 ft. ²) | Recommendation (lbs. P ₂ O ₅ /1000 ft. ²) |
| 0 | 0 | 4.4 | 3.4 | 2.5 | 2.5 lbs. year (Maximum single application of 1.5 lbs.) |
| 2 | 1.3 | 4.1 | 3.1 | 2.2 | |
| 4 | 2.7 | 3.9 | 2.7 | 1.9 | |
| 6 | 4 | 3.6 | 2.4 | 1.6 | |
| 8 | 5.3 | 3.4 | 2.0 | 1.3 | |
| 10 | 6.7 | 3.1 | 1.7 | 1.0 | |
| 12 | 8 | 2.8 | 1.4 | 0.7 | |
| 14 | 9.3 | 2.6 | 1.0 | 0.4 | |
| 16 | 10.7 | 2.3 | 0.7 | 0.1 | |
| 18 | 12 | 2.1 | 0.3 | 0.0 | |
| 20 | 13.3 | 1.8 | 0.0 | | 109 lbs/acre year (maximum single application of 65 lbs/acre) |
| 22 | 14.7 | 1.5 | | | |
| 24 | 16 | 1.3 | | | |
| 26 | 17.3 | 1.0 | | | |
| 28 | 18.7 | 0.8 | | | |
| 30 | 20 | 0.5 | | | |
| 32 | 21.3 | 0.2 | | | |
| 34 | 22.7 | 0.0 | | | |

Web resources: www.turf.msu.edu or www.bephosphorusmart.msu.edu

Street Surface Treatments - 2017

Project Listing of Streets

| Street Name | Limits | | Beginning Milepoint | Ending Milepoint | Length (miles) Centerline | Lane | Area (Syd) | Proposed Surface Treatment |
|------------------------------|-----------------------------|----------------------------|------------------------|------------------|------------------------------|-------|------------|------------------------------|
| | Beginning | Ending | | | | | | |
| MAJOR STREETS | | | | | | | | |
| Fuller Road | East End Huron River Bridge | Fuller Ct | 0.000 | 0.949 | 0.949 | 3.322 | 29,115 | Micro-Surface, Single Course |
| Green Road | Plymouth Rd | Gettysburg Rd/Burbank Dr | 1.175 | 2.006 | 0.831 | 3.324 | 24,242 | Micro-Surface, Single Course |
| | | | MAJOR STREETS SUBTOTAL | | 1.780 | 6.646 | 53,357 | |
| MINOR (LOCAL) STREETS | | | | | | | | |
| AREA No. 1 | | | | | | | | |
| Creek Drive | La Fere St | Packard St | 0.238 | 0.474 | 0.236 | 0.472 | 4,271 | Cape Seal |
| Elmwood Street | Packard St | Norwood St | 0.000 | 0.149 | 0.149 | 0.298 | 2,798 | Cape Seal |
| La Fere Street | Creek Dr | La Salle St | 0.000 | 0.105 | 0.105 | 0.210 | 1,540 | Cape Seal |
| Lorraine Street | Platt Rd | Pittsview Dr | 0.000 | 0.379 | 0.379 | 0.758 | 6,031 | Cape Seal |
| Oakwood Street | Platt Rd | Bellwood Ave | 0.000 | 0.198 | 0.198 | 0.396 | 3,486 | Cape Seal |
| Redwood Avenue | Platt Rd | Creek Dr | 0.312 | 0.427 | 0.115 | 0.230 | 1,620 | Cape Seal |
| Elmwood Street | Norwood St | Edgewood Dr | 0.149 | 0.440 | 0.291 | 0.582 | 5,217 | Seal, Slurry, Modified |
| La Salle Street | Lorraine St | La Fere St | 0.000 | 0.257 | 0.257 | 0.514 | 3,770 | Seal, Slurry, Modified |
| | | | Area No. 1 SUBTOTAL | | 1.730 | 3.460 | 28,733 | |
| AREA No. 2 | | | | | | | | |
| Brooklyn Avenue | Packard St | Ferdon Rd | 0.000 | 0.368 | 0.368 | 0.736 | 5,743 | Cape Seal |
| Golden Avenue | E Stadium Blvd | Granger Ave | 0.000 | 0.227 | 0.227 | 0.454 | 4,205 | Cape Seal |
| Hermitage Road | Ferdon Rd | Wallingford Rd | 0.000 | 0.185 | 0.185 | 0.370 | 2,607 | Cape Seal |
| Lincoln Avenue | Shadford Rd | Granger Ave | 0.000 | 0.194 | 0.194 | 0.388 | 2,920 | Cape Seal |
| Morton Avenue | Lincoln Ave | Woodside Rd | 0.091 | 0.545 | 0.454 | 0.908 | 8,352 | Cape Seal |
| South Boulevard | Packard St | Ferdon Rd | 0.096 | 0.330 | 0.234 | 0.468 | 3,720 | Cape Seal |
| Woodlawn Avenue | Sheehan Ave | Packard St | 0.000 | 0.185 | 0.185 | 0.370 | 2,822 | Cape Seal |
| | | | Area No. 2 SUBTOTAL | | 1.847 | 3.694 | 30,369 | |
| AREA No. 3 | | | | | | | | |
| Frederick Drive | Green Rd | Greenbrier Dr/Middleton Dr | 0.000 | 0.261 | 0.261 | 0.522 | 4,337 | Cape Seal |
| Middleton Drive | Frederick Dr | Greenbrier Dr/Frederick Dr | 0.000 | 0.346 | 0.346 | 0.692 | 6,091 | Cape Seal |
| | | | Area No. 3 SUBTOTAL | | 0.607 | 1.214 | 10,428 | |
| AREA No. 4 | | | | | | | | |
| Crosby Crescent | Snyder Ave | Clague St | 0.000 | 0.187 | 0.187 | 0.374 | 3,216 | Cape Seal |
| Rugby Court | Wiltshire Dr | End of Cul-de-sac | 0.000 | 0.060 | 0.060 | 0.120 | 1,092 | Cape Seal |
| Van Dusen Drive | Crosby Cres | Pauline Blvd | 0.000 | 0.177 | 0.177 | 0.354 | 3,116 | Cape Seal |
| Algonac Street | Naples Ct | Clague St | 0.688 | 0.784 | 0.096 | 0.192 | 1,690 | Seal, Slurry, Modified |
| Clague Street | Algonac Ave | Van Dusen Dr | 0.784 | 0.912 | 0.128 | 0.256 | 2,253 | Seal, Slurry, Modified |
| Naples Court | Snyder Ave/Algonac St | End of Cul-de-sac | 0.000 | 0.078 | 0.078 | 0.156 | 1,282 | Seal, Slurry, Modified |
| Snyder Avenue | Birk Ave | Naples Ct | 0.495 | 0.688 | 0.193 | 0.386 | 3,183 | Seal, Slurry, Modified |
| | | | Area No. 4 SUBTOTAL | | 0.919 | 1.838 | 15,832 | |

Street Surface Treatments - 2017

Project Listing of Streets

| Street Name | Limits | | Beginning Milepoint | Ending Milepoint | Length (miles) | | Area (Syd) | Proposed Surface Treatment |
|--------------------|-------------------|-------------------|---|------------------|----------------|---------------|----------------|------------------------------|
| | Beginning | Ending | | | Centerline | Lane | | |
| AREA No. 5 | | | | | | | | |
| Churchill Drive | End of Cul-de-sac | Scio Church Rd | 0.000 | 0.332 | 0.332 | 0.664 | 5,860 | Cape Seal |
| Delaware Drive | S 7th St | Mershon Dr | 0.320 | 0.540 | 0.220 | 0.440 | 3,614 | Cape Seal |
| Steeplechase Drive | Churchill Dr | Blaney Dr | 0.000 | 0.102 | 0.102 | 0.204 | 1,736 | Cape Seal |
| Wiltshire Drive | Churchill Dr | End of Cul-de-sac | 0.000 | 0.212 | 0.212 | 0.424 | 3,771 | Cape Seal |
| Morehead Drive | Churchill Dr | S 7th St | 0.000 | 0.367 | 0.367 | 0.734 | 6,208 | Seal, Slurry, Modified |
| | | | Area No. 5 SUBTOTAL | | 1.233 | 2.466 | 21,189 | |
| | | | MINOR (LOCAL) STREETS SUBTOTAL | | 4.184 | 8.368 | 106,551 | |
| | | | PROJECT TOTALS (MAJOR & MINOR) | | 5.964 | 15.014 | 159,908 | |
| | | | | | 4.926 | 9.852 | 82,948 | Cape Seal |
| | | | | | 1.780 | 6.646 | 53,357 | Micro-Surface, Single Course |
| | | | | | 1.410 | 2.820 | 23,603 | Seal, Slurry, Modified |

NOTES:

- 1) See Detailed Specification for Progress Schedule and the associated "Schedule of Streets" for scheduling requirements/restrictions.
- 2) Cape Seal involves placing a single course of chip seal followed a single course of micro-surfacing on major streets, or followed by a single course of modified slurry seal on minor (local) streets. This work will be paid respectively as Seal, Single Chip, Modified and Micro-Surface, Single Course or as Seal, Single Chip, Modified and Seal, Slurry, Modified.

Street Surface Treatment Project - FY2019

Project Log of Streets

Major Street Location - Fuller Road

| <u>Line No.</u> | <u>ItemCode</u> | <u>Item Description</u> | <u>Unit</u> | <u>Quantity</u> |
|-----------------|-----------------|--|-------------|-----------------|
| 70 | 5017011 | _Cold Milling HMA Surface, Modified | Syd | 1,222.00 |
| 80 | 5017031 | _Hand Patching, Modified, Major Streets | Ton | 202.00 |
| 110 | 5047011 | _Micro-Surface, Single Course | Syd | 29,115.00 |
| 160 | 8110195 | Pavt Mrkg, Thermopl, 4 inch, White | Ft | 2,600.00 |
| 170 | 8110196 | Pavt Mrkg, Thermopl, 4 inch, Yellow | Ft | 9,200.00 |
| 210 | 8110213 | Pavt Mrkg, Thermopl, 12 inch, Cross Hatching, Yellow | Ft | 170.00 |
| 220 | 8110214 | Pavt Mrkg, Thermopl, 12 inch, Crosswalk | Ft | 750.00 |
| 230 | 8110218 | Pavt Mrkg, Thermopl, 24 inch, Stop Bar | Ft | 275.00 |
| 240 | 8110343 | Rem Spec Mrkg | Sft | 784.00 |
| 250 | 8117050 | _Pavt Mrkg, Thermopl, Lt Turn Arrow Sym | Ea | 14.00 |
| 260 | 8117050 | _Pavt Mrkg, Thermopl, Rt Turn Arrow Sym | Ea | 2.00 |
| 270 | 8117050 | _Pavt Mrkg, Thermopl, Thru Arrow Sym | Ea | 2.00 |
| 280 | 8117050 | _Pavt Mrkg, Thermopl, Only | Ea | 9.00 |
| 290 | 8120012 | Barricade, Type III, High Intensity, Double Sided, Lighted, Furn | Ea | 7.00 |
| 300 | 8120013 | Barricade, Type III, High Intensity, Double Sided, Lighted, Oper | Ea | 7.00 |
| 310 | 8120030 | Channelizing Device, 42 inch, Furn | Ea | 351.00 |
| 320 | 8120031 | Channelizing Device, 42 inch, Oper | Ea | 351.00 |
| 330 | 8120140 | Lighted Arrow, Type C, Furn | Ea | 2.00 |
| 340 | 8120141 | Lighted Arrow, Type C, Oper | Ea | 2.00 |
| 350 | 8120210 | Pavt Mrkg, Longit, 6 inch or Less Width, Rem | Ft | 11,800.00 |
| 360 | 8120211 | Pavt Mrkg, Longit, Greater than 6 inch Width, Rem | Ft | 1,195.00 |
| 370 | 8120235 | Pavt Mrkg, Wet Retrflc, Type NR, Paint, 4 inch, White, Temp | Ft | 2,600.000 |
| 380 | 8120236 | Pavt Mrkg, Wet Retrflc, Type NR, Paint, 4 inch, Yellow, Temp | Ft | 9,200.000 |
| 390 | 8120250 | Plastic Drum, High Intensity, Furn | Ea | 20.00 |
| 400 | 8120251 | Plastic Drum, High Intensity, Oper | Ea | 20.00 |
| 410 | 8120280 | Raised Pavt Marker, Temp, Type 1, White, Monodirectional | Ea | 52.000 |
| 420 | 8120281 | Raised Pavt Marker, Temp, Type 1, Yellow, Bidirectional | Ea | 184.000 |
| 450 | 8120331 | Sign, Portable, Changeable Message, Oper | Ea | 3.00 |
| 460 | 8120350 | Sign, Type B, Temp, Prismatic, Furn | Sft | 1,246.00 |
| 470 | 8120351 | Sign, Type B, Temp, Prismatic, Oper | Sft | 1,246.00 |

Street Surface Treatment Project - FY2019

Project Log of Streets

Major Street Location - Green Road

| <u>Line No.</u> | <u>ItemCode</u> | <u>Item Description</u> | <u>Unit</u> | <u>Quantity</u> |
|-----------------|-----------------|--|-------------|-----------------|
| 70 | 5017011 | _Cold Milling HMA Surface, Modified | Syd | 1,060.00 |
| 80 | 5017031 | _Hand Patching, Modified, Major Streets | Ton | 175.00 |
| 110 | 5047011 | _Micro-Surface, Single Course | Syd | 24,242.24 |
| 140 | 8110049 | Pavt Mrkg, Ovly Cold Plastic, Direction Arrow Sym, Bike | Ea | 1.00 |
| 150 | 8110058 | Pavt Mrkg, Ovly Cold Plastic, Bike, Small Sym | Ea | 1.00 |
| 160 | 8110195 | Pavt Mrkg, Thermopl, 4 inch, White | Ft | 2,800.00 |
| 170 | 8110196 | Pavt Mrkg, Thermopl, 4 inch, Yellow | Ft | 5,200.00 |
| 190 | 8110198 | Pavt Mrkg, Thermopl, 6 inch, White | Ft | 2,000.00 |
| 200 | 8110212 | Pavt Mrkg, Thermopl, 12 inch, Cross Hatching, White | Ft | 120.00 |
| 210 | 8110213 | Pavt Mrkg, Thermopl, 12 inch, Cross Hatching, Yellow | Ft | 916.00 |
| 220 | 8110214 | Pavt Mrkg, Thermopl, 12 inch, Crosswalk | Ft | 100.00 |
| 240 | 8110343 | Rem Spec Mrkg | Sft | 241.00 |
| 250 | 8117050 | _Pavt Mrkg, Thermopl, Lt Turn Arrow Sym | Ea | 2.00 |
| 260 | 8117050 | _Pavt Mrkg, Thermopl, Rt Turn Arrow Sym | Ea | 1.00 |
| 280 | 8117050 | _Pavt Mrkg, Thermopl, Only | Ea | 3.00 |
| 290 | 8120012 | Barricade, Type III, High Intensity, Double Sided, Lighted, Furn | Ea | 5.00 |
| 300 | 8120013 | Barricade, Type III, High Intensity, Double Sided, Lighted, Oper | Ea | 5.00 |
| 310 | 8120030 | Channelizing Device, 42 inch, Furn | Ea | 352.00 |
| 320 | 8120031 | Channelizing Device, 42 inch, Oper | Ea | 352.00 |
| 330 | 8120140 | Lighted Arrow, Type C, Furn | Ea | 2.00 |
| 340 | 8120141 | Lighted Arrow, Type C, Oper | Ea | 2.00 |
| 350 | 8120210 | Pavt Mrkg, Longit, 6 inch or Less Width, Rem | Ft | 10,000.00 |
| 360 | 8120211 | Pavt Mrkg, Longit, Greater than 6 inch Width, Rem | Ft | 1,136.00 |
| 370 | 8120235 | Pavt Mrkg, Wet Retrflec, Type NR, Paint, 4 inch, White, Temp | Ft | 2,800.000 |
| 380 | 8120236 | Pavt Mrkg, Wet Retrflec, Type NR, Paint, 4 inch, Yellow, Temp | Ft | 5,200.000 |
| 390 | 8120250 | Plastic Drum, High Intensity, Furn | Ea | 20.00 |
| 400 | 8120251 | Plastic Drum, High Intensity, Oper | Ea | 20.00 |
| 410 | 8120280 | Raised Pavt Marker, Temp, Type 1, White, Monodirectional | Ea | 56.000 |
| 420 | 8120281 | Raised Pavt Marker, Temp, Type 1, Yellow, Bidirectional | Ea | 104.000 |
| 450 | 8120331 | Sign, Portable, Changeable Message, Oper | Ea | 2.00 |
| 460 | 8120350 | Sign, Type B, Temp, Prismatic, Furn | Sft | 726.00 |
| 470 | 8120351 | Sign, Type B, Temp, Prismatic, Oper | Sft | 726.00 |

Street Surface Treatment Project - FY2019

Project Log of Streets

Minor (Local) Street Location - Area 1

| <u>Line No.</u> | <u>ItemCode</u> | <u>Item Description</u> | <u>Unit</u> | <u>Quantity</u> |
|-----------------|-----------------|--|-------------|-----------------|
| 70 | 5017011 | _Cold Milling HMA Surface, Modified | Syd | 431.00 |
| 90 | 5017031 | _Hand Patching, Modified, Minor (Local) Streets | Ton | 60.00 |
| 120 | 5057011 | _Seal, Single Chip, Modified | Syd | 19,746.00 |
| 130 | 5067011 | _Seal, Slurry, Modified | Syd | 28,733.00 |
| 290 | 8120012 | Barricade, Type III, High Intensity, Double Sided, Lighted, Furn | Ea | 20.00 |
| 300 | 8120013 | Barricade, Type III, High Intensity, Double Sided, Lighted, Oper | Ea | 20.00 |
| 330 | 8120140 | Lighted Arrow, Type C, Furn | Ea | 2.00 |
| 340 | 8120141 | Lighted Arrow, Type C, Oper | Ea | 2.00 |
| 390 | 8120250 | Plastic Drum, High Intensity, Furn | Ea | 25.00 |
| 400 | 8120251 | Plastic Drum, High Intensity, Oper | Ea | 25.00 |
| 450 | 8120331 | Sign, Portable, Changeable Message, Oper | Ea | 2.00 |
| 460 | 8120350 | Sign, Type B, Temp, Prismatic, Furn | Sft | 200.00 |
| 470 | 8120351 | Sign, Type B, Temp, Prismatic, Oper | Sft | 200.00 |

Street Surface Treatment Project - FY2019

Project Log of Streets

Minor (Local) Street Location - Area 2

| <u>Line No.</u> | <u>ItemCode</u> | <u>Item Description</u> | <u>Unit</u> | <u>Quantity</u> |
|-----------------|-----------------|--|-------------|-----------------|
| 70 | 5017011 | _Cold Milling HMA Surface, Modified | Syd | 456.00 |
| 90 | 5017031 | _Hand Patching, Modified, Minor (Local) Streets | Ton | 63.00 |
| 120 | 5057011 | _Seal, Single Chip, Modified | Syd | 30,369.00 |
| 130 | 5067011 | _Seal, Slurry, Modified | Syd | 30,369.00 |
| 290 | 8120012 | Barricade, Type III, High Intensity, Double Sided, Lighted, Furn | Ea | 20.00 |
| 300 | 8120013 | Barricade, Type III, High Intensity, Double Sided, Lighted, Oper | Ea | 20.00 |
| 330 | 8120140 | Lighted Arrow, Type C, Furn | Ea | 2.00 |
| 340 | 8120141 | Lighted Arrow, Type C, Oper | Ea | 2.00 |
| 390 | 8120250 | Plastic Drum, High Intensity, Furn | Ea | 25.00 |
| 400 | 8120251 | Plastic Drum, High Intensity, Oper | Ea | 25.00 |
| 450 | 8120331 | Sign, Portable, Changeable Message, Oper | Ea | 2.00 |
| 460 | 8120350 | Sign, Type B, Temp, Prismatic, Furn | Sft | 200.00 |
| 470 | 8120351 | Sign, Type B, Temp, Prismatic, Oper | Sft | 200.00 |

Street Surface Treatment Project - FY2019

Project Log of Streets

Minor (Local) Street Location - Area 3

| <u>Line No.</u> | <u>ItemCode</u> | <u>Item Description</u> | <u>Unit</u> | <u>Quantity</u> |
|-----------------|-----------------|--|-------------|-----------------|
| 70 | 5017011 | _Cold Milling HMA Surface, Modified | Syd | 157.00 |
| 90 | 5017031 | _Hand Patching, Modified, Minor (Local) Streets | Ton | 22.00 |
| 120 | 5057011 | _Seal, Single Chip, Modified | Syd | 10,428.00 |
| 130 | 5067011 | _Seal, Slurry, Modified | Syd | 10,428.00 |
| 290 | 8120012 | Barricade, Type III, High Intensity, Double Sided, Lighted, Furn | Ea | 10.00 |
| 300 | 8120013 | Barricade, Type III, High Intensity, Double Sided, Lighted, Oper | Ea | 10.00 |
| 330 | 8120140 | Lighted Arrow, Type C, Furn | Ea | 2.00 |
| 340 | 8120141 | Lighted Arrow, Type C, Oper | Ea | 2.00 |
| 390 | 8120250 | Plastic Drum, High Intensity, Furn | Ea | 15.00 |
| 400 | 8120251 | Plastic Drum, High Intensity, Oper | Ea | 15.00 |
| 450 | 8120331 | Sign, Portable, Changeable Message, Oper | Ea | 2.00 |
| 460 | 8120350 | Sign, Type B, Temp, Prismatic, Furn | Sft | 200.00 |
| 470 | 8120351 | Sign, Type B, Temp, Prismatic, Oper | Sft | 200.00 |

Street Surface Treatment Project - FY2019

Project Log of Streets

Minor (Local) Street Location - Area 4

| <u>Line No.</u> | <u>ItemCode</u> | <u>Item Description</u> | <u>Unit</u> | <u>Quantity</u> |
|-----------------|-----------------|--|-------------|-----------------|
| 70 | 5017011 | _Cold Milling HMA Surface, Modified | Syd | 238.00 |
| 90 | 5017031 | _Hand Patching, Modified, Minor (Local) Streets | Ton | 33.00 |
| 120 | 5057011 | _Seal, Single Chip, Modified | Syd | 7,424.00 |
| 130 | 5067011 | _Seal, Slurry, Modified | Syd | 15,832.00 |
| 290 | 8120012 | Barricade, Type III, High Intensity, Double Sided, Lighted, Furn | Ea | 10.00 |
| 300 | 8120013 | Barricade, Type III, High Intensity, Double Sided, Lighted, Oper | Ea | 10.00 |
| 330 | 8120140 | Lighted Arrow, Type C, Furn | Ea | 2.00 |
| 340 | 8120141 | Lighted Arrow, Type C, Oper | Ea | 2.00 |
| 390 | 8120250 | Plastic Drum, High Intensity, Furn | Ea | 15.00 |
| 400 | 8120251 | Plastic Drum, High Intensity, Oper | Ea | 15.00 |
| 450 | 8120331 | Sign, Portable, Changeable Message, Oper | Ea | 2.00 |
| 460 | 8120350 | Sign, Type B, Temp, Prismatic, Furn | Sft | 200.00 |
| 470 | 8120351 | Sign, Type B, Temp, Prismatic, Oper | Sft | 200.00 |

Street Surface Treatment Project - FY2019

Project Log of Streets

Minor (Local) Street Location - Area 5

| <u>Line No.</u> | <u>ItemCode</u> | <u>Item Description</u> | <u>Unit</u> | <u>Quantity</u> |
|-----------------|-----------------|--|-------------|-----------------|
| 70 | 5017011 | _Cold Milling HMA Surface, Modified | Syd | 318.00 |
| 90 | 5017031 | _Hand Patching, Modified, Minor (Local) Streets | Ton | 44.00 |
| 120 | 5057011 | _Seal, Single Chip, Modified | Syd | 14,981.00 |
| 130 | 5067011 | _Seal, Slurry, Modified | Syd | 21,189.00 |
| 290 | 8120012 | Barricade, Type III, High Intensity, Double Sided, Lighted, Furn | Ea | 10.00 |
| 300 | 8120013 | Barricade, Type III, High Intensity, Double Sided, Lighted, Oper | Ea | 10.00 |
| 330 | 8120140 | Lighted Arrow, Type C, Furn | Ea | 2.00 |
| 340 | 8120141 | Lighted Arrow, Type C, Oper | Ea | 2.00 |
| 390 | 8120250 | Plastic Drum, High Intensity, Furn | Ea | 15.00 |
| 400 | 8120251 | Plastic Drum, High Intensity, Oper | Ea | 15.00 |
| 450 | 8120331 | Sign, Portable, Changeable Message, Oper | Ea | 2.00 |
| 460 | 8120350 | Sign, Type B, Temp, Prismatic, Furn | Sft | 200.00 |
| 470 | 8120351 | Sign, Type B, Temp, Prismatic, Oper | Sft | 200.00 |

City of Ann Arbor Street Surface Treatment Project - FY2019

Minor (Local) Street Locations

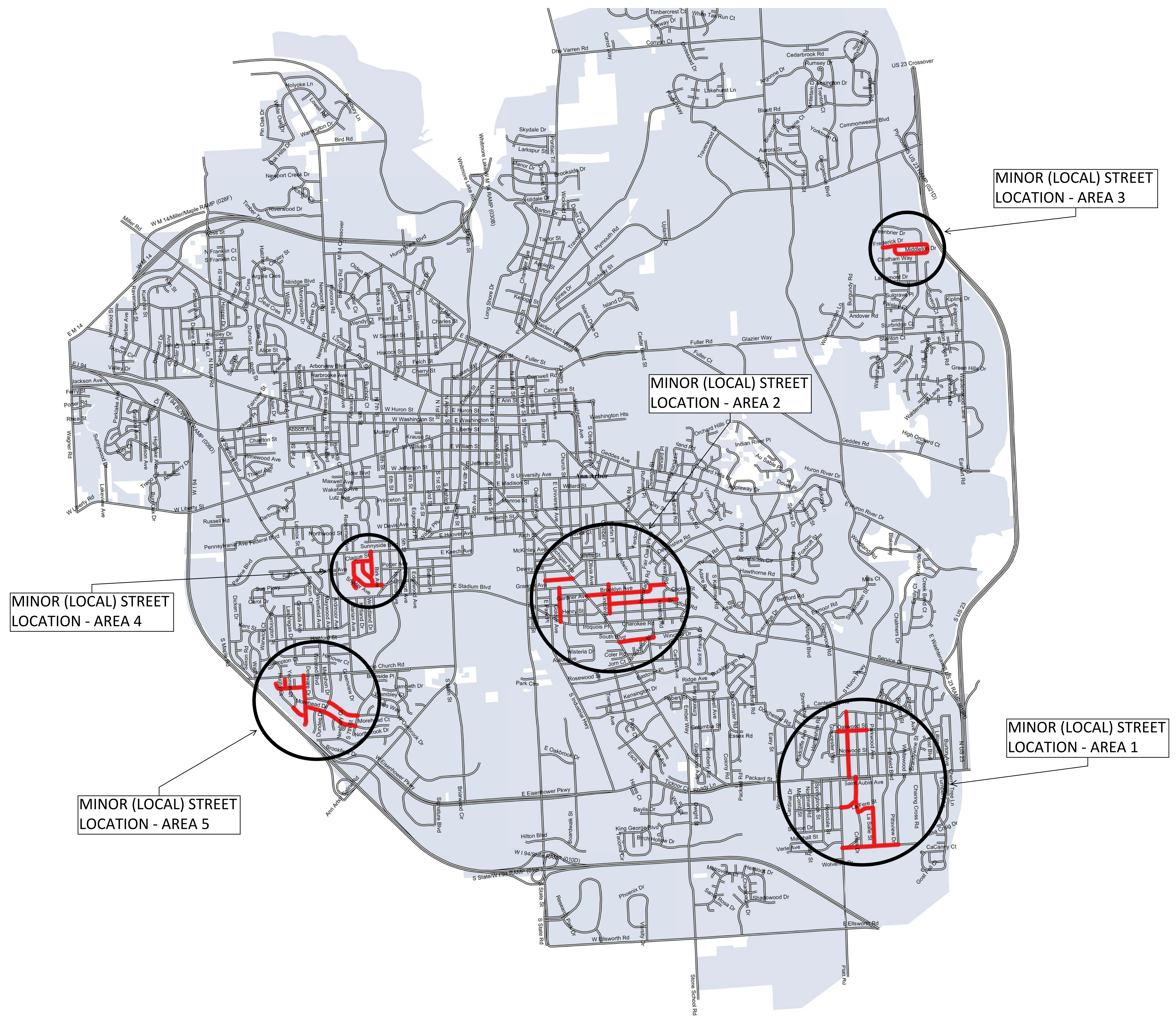

**CITY OF ANN ARBOR
LIVING WAGE ORDINANCE DECLARATION OF COMPLIANCE**

The Ann Arbor Living Wage Ordinance (Section 1:811-1:821 of Chapter 23 of Title I of the Code) requires that an employer who is (a) a contractor providing services to or for the City for a value greater than \$10,000 for any twelve-month contract term, or (b) a recipient of federal, state, or local grant funding administered by the City for a value greater than \$10,000, or (c) a recipient of financial assistance awarded by the City for a value greater than \$10,000, shall pay its employees a prescribed minimum level of compensation (i.e., Living Wage) for the time those employees perform work on the contract or in connection with the grant or financial assistance. The Living Wage must be paid to these employees for the length of the contract/program.

Companies employing fewer than 5 persons and non-profits employing fewer than 10 persons are exempt from compliance with the Living Wage Ordinance. If this exemption applies to your company/non-profit agency please check here No. of employees__

The Contractor or Grantee agrees:

- (a) To pay each of its employees whose wage level is not required to comply with federal, state or local prevailing wage law, for work covered or funded by a contract with or grant from the City, no less than the Living Wage. The current Living Wage is defined as \$13.22/hour for those employers that provide employee health care (as defined in the Ordinance at Section 1:815 Sec. 1 (a)), or no less than \$14.75/hour for those employers that do not provide health care. The Contractor or Grantor understands that the Living Wage is adjusted and established annually on April 30 in accordance with the Ordinance and covered employers shall be required to pay the adjusted amount thereafter to be in compliance with Section 1:815(3).

Check the applicable box below which applies to your workforce

- Employees who are assigned to any covered City contract/grant will be paid at or above the applicable living wage without health benefits
- Employees who are assigned to any covered City contract/grant will be paid at or above the applicable living wage with health benefits

- (b) To post a notice approved by the City regarding the applicability of the Living Wage Ordinance in every work place or other location in which employees or other persons contracting for employment are working.
- (c) To provide to the City payroll records or other documentation within ten (10) business days from the receipt of a request by the City.
- (d) To permit access to work sites to City representatives for the purposes of monitoring compliance, and investigating complaints or non-compliance.
- (e) To take no action that would reduce the compensation, wages, fringe benefits, or leave available to any employee covered by the Living Wage Ordinance or any person contracted for employment and covered by the Living Wage Ordinance in order to pay the living wage required by the Living Wage Ordinance.

The undersigned states that he/she has the requisite authority to act on behalf of his/her employer in these matters and has offered to provide the services or agrees to accept financial assistance in accordance with the terms of the Living Wage Ordinance. The undersigned certifies that he/she has read and is familiar with the terms of the Living Wage Ordinance, obligates the Employer/Grantee to those terms and acknowledges that if his/her employer is found to be in violation of Ordinance it may be subject to civil penalties and termination of the awarded contract or grant of financial assistance.

Company Name

Street Address

Signature of Authorized Representative

Date

City, State, Zip

Print Name and Title

Phone/Email address

**CITY OF ANN ARBOR
LIVING WAGE ORDINANCE**

RATE EFFECTIVE APRIL 30, 2018 - ENDING APRIL 29, 2019

\$13.22 per hour

If the employer provides health care benefits*

\$14.75 per hour

If the employer does **NOT** provide health care benefits*

Employers providing services to or for the City of Ann Arbor or recipients of grants or financial assistance from the City of Ann Arbor for a value of more than \$10,000 in a twelve-month period of time must pay those employees performing work on a City of Ann Arbor contract or grant, the above living wage.

ENFORCEMENT

The City of Ann Arbor may recover back wages either administratively or through court action for the employees that have been underpaid in violation of the law. Persons denied payment of the living wage have the right to bring a civil action for damages in addition to any action taken by the City.

Violation of this Ordinance is punishable by fines of not more than \$500/violation plus costs, with each day being considered a separate violation. Additionally, the City of Ann Arbor has the right to modify, terminate, cancel or suspend a contract in the event of a violation of the Ordinance.

* Health Care benefits include those paid for by the employer or making an employer contribution toward the purchase of health care. The employee contribution must not exceed \$.50 an hour for an average work week; and the employer cost or contribution must equal no less than \$1/hr for the average work week.

The Law Requires Employers to Display This Poster Where Employees Can Readily See It.

**For Additional Information or to File a Complaint contact
Colin Spencer at 734/794-6500 or cspencer@a2gov.org**



| |
|--|
| Vendor Conflict of Interest Disclosure Form |
|--|

All vendors interested in conducting business with the City of Ann Arbor must complete and return the Vendor Conflict of Interest Disclosure Form in order to be eligible to be awarded a contract. Please note that all vendors are subject to comply with the City of Ann Arbor’s conflict of interest policies as stated within the certification section below.

If a vendor has a relationship with a City of Ann Arbor official or employee, an immediate family member of a City of Ann Arbor official or employee, the vendor shall disclose the information required below.

1. No City official or employee or City employee’s immediate family member has an ownership interest in vendor’s company or is deriving personal financial gain from this contract.
2. No retired or separated City official or employee who has been retired or separated from the City for less than one (1) year has an ownership interest in vendor’s Company.
3. No City employee is contemporaneously employed or prospectively to be employed with the vendor.
4. Vendor hereby declares it has not and will not provide gifts or hospitality of any dollar value or any other gratuities to any City employee or elected official to obtain or maintain a contract.
5. Please note any exceptions below:

| Conflict of Interest Disclosure* | |
|---|---|
| Name of City of Ann Arbor employees, elected officials or immediate family members with whom there may be a potential conflict of interest. | <input type="checkbox"/> Relationship to employee <hr style="border: 0; border-top: 1px solid black;"/> <input type="checkbox"/> Interest in vendor’s company <input type="checkbox"/> Other (please describe in box below) |
| | |

*Disclosing a potential conflict of interest does not disqualify vendors. In the event vendors do not disclose potential conflicts of interest and they are detected by the City, vendor will be exempt from doing business with the City.

| I certify that this Conflict of Interest Disclosure has been examined by me and that its contents are true and correct to my knowledge and belief and I have the authority to so certify on behalf of the Vendor by my signature below: | | |
|--|----------------------------|---|
| | | |
| Vendor Name | Vendor Phone Number | |
| | | |
| Signature of Vendor Authorized Representative | Date | Printed Name of Vendor Authorized Representative |
| | | |

Questions about this form? Contact Procurement Office City of Ann Arbor Phone: 734/794-6500, procurement@a2gov.org

CITY OF ANN ARBOR NON-DISCRIMINATION ORDINANCE

Relevant provisions of Chapter 112, Nondiscrimination, of the Ann Arbor City Code are included below.
You can review the entire ordinance at www.a2gov.org/humanrights.

Intent: It is the intent of the city that no individual be denied equal protection of the laws; nor shall any individual be denied the enjoyment of his or her civil or political rights or be discriminated against because of actual or perceived age, arrest record, color, disability, educational association, familial status, family responsibilities, gender expression, gender identity, genetic information, height, HIV status, marital status, national origin, political beliefs, race, religion, sex, sexual orientation, source of income, veteran status, victim of domestic violence or stalking, or weight.

Discriminatory Employment Practices: No person shall discriminate in the hire, employment, compensation, work classifications, conditions or terms, promotion or demotion, or termination of employment of any individual. No person shall discriminate in limiting membership, conditions of membership or termination of membership in any labor union or apprenticeship program.

Discriminatory Effects: No person shall adopt, enforce or employ any policy or requirement which has the effect of creating unequal opportunities according to actual or perceived age, arrest record, color, disability, educational association, familial status, family responsibilities, gender expression, gender identity, genetic information, height, HIV status, marital status, national origin, political beliefs, race, religion, sex, sexual orientation, source of income, veteran status, victim of domestic violence or stalking, or weight for an individual to obtain housing, employment or public accommodation, except for a bona fide business necessity. Such a necessity does not arise due to a mere inconvenience or because of suspected objection to such a person by neighbors, customers or other persons.

Nondiscrimination by City Contractors: All contractors proposing to do business with the City of Ann Arbor shall satisfy the contract compliance administrative policy adopted by the City Administrator in accordance with the guidelines of this section. All city contractors shall ensure that applicants are employed and that employees are treated during employment in a manner which provides equal employment opportunity and tends to eliminate inequality based upon any classification protected by this chapter. All contractors shall agree not to discriminate against an employee or applicant for employment with respect to hire, tenure, terms, conditions, or privileges of employment, or a matter directly or indirectly related to employment, because of any applicable protected classification. All contractors shall be required to post a copy of Ann Arbor's Non-Discrimination Ordinance at all work locations where its employees provide services under a contract with the city.

Complaint Procedure: If any individual believes there has been a violation of this chapter, he/she may file a complaint with the City's Human Rights Commission. The complaint must be filed within 180 calendar days from the date of the individual's knowledge of the allegedly discriminatory action or 180 calendar days from the date when the individual should have known of the allegedly discriminatory action. A complaint that is not filed within this timeframe cannot be considered by the Human Rights Commission. To file a complaint, first complete the complaint form, which is available at www.a2gov.org/humanrights. Then submit it to the Human Rights Commission by e-mail (hrc@a2gov.org), by mail (Ann Arbor Human Rights Commission, PO Box 8647, Ann Arbor, MI 48107), or in person (City Clerk's Office). For further information, please call the commission at 734-794-6141 or e-mail the commission at hrc@a2gov.org.

Private Actions For Damages or Injunctive Relief: To the extent allowed by law, an individual who is the victim of discriminatory action in violation of this chapter may bring a civil action for appropriate injunctive relief or damages or both against the person(s) who acted in violation of this chapter.

THIS IS AN OFFICIAL GOVERNMENT NOTICE AND
MUST BE DISPLAYED WHERE EMPLOYEES CAN READILY SEE IT.

