

CITY OF ANN ARBOR
INVITATION TO BID



2018 Water Main and Sanitary Sewer Projects

ITB No. 4524

Due Date: Wednesday, March 28, 2018 at 10:00 A.M. (local time)

Public Services - Engineering

Issued By:

City of Ann Arbor
Procurement Unit
301 E. Huron Street
Ann Arbor, MI 48104

TABLE OF CONTENTS

TABLE OF CONTENTS.....	TC-1
NOTICE OF PRE-BID CONFERENCE.....	NP-1
INSTRUCTIONS TO BIDDERS.....	IB-1 to 5
INVITATION TO BID.....	ITB-1 to 3
BID FORMS.....	BF-1 to 9
CONTRACT.....	C-1 to 4
BOND FORMS.....	B-1 to 2
GENERAL CONDITIONS.....	GC-1 to 16
STANDARD SPECIFICATIONS.....	SS-1
DETAILED SPECIFICATION.....	DS-1 to 77
REVISED STANDARD DETAILS.....	APPENDIX 1
SOIL BORINGS.....	APPENDIX 2

ATTACHMENTS

- City of Ann Arbor Prevailing Wage Declaration Form*
- City of Ann Arbor Living Wage Forms*
- City of Ann Arbor Vendor Conflict of Interest Disclosure Form*
- City of Ann Arbor Non-Discrimination Ordinance Notice and Declaration Form*

NOTICE OF PRE-BID CONFERENCE

A **mandatory** pre-bid conference for this project will be held on **Thursday, March 15, 2018 at 10:00 A.M** at **5th Floor Conference Room, Larcom City Hall, 301 E. Huron Street, Ann Arbor, MI 48104**. **Failure to attend the meeting and sign the ITB No. 4524 sign-in sheet at the pre-bid meeting will automatically disqualify a bidder from submitting a valid bid.** Any bid submitted by a party not attending and signing the roster at the pre-bid meeting will not be opened or considered. Administrative and technical questions regarding this project will be answered at this time. The pre-bid meeting is for information only. Any answers furnished will not be official until verified in writing by the Financial Service Area, Procurement Unit. Answers that change or substantially clarify the bid will be affirmed in an addendum.

INSTRUCTIONS TO BIDDERS

General

Work to be done under this Contract is generally described through the detailed specifications and must be completed fully in accordance with the contract documents. All work to be done under this Contract is located in or near the City of Ann Arbor.

Any Bid which does not conform fully to these instructions may be rejected.

Preparation of Bids

Bids should be prepared providing a straight-forward, concise description of the Bidder's ability to meet the requirements of the ITB. Bids shall be written in ink or typewritten. No erasures are permitted. Mistakes may be crossed out and corrected and must be initialed and dated in ink by the person signing the Bid.

Bids must be submitted on the "Bid Forms" provided with each blank properly filled in. If forms are not fully completed it may disqualify the bid. No alternative bid will be considered unless alternative bids are specifically requested. If alternatives are requested, any deviation from the specification must be fully described, in detail on the "Alternate" section of Bid form.

Each person signing the Bid certifies that he/she is the person in the Bidder's firm/organization responsible for the decision as to the fees being offered in the Bid and has not and will not participated in any action contrary to the terms of this provision.

Questions or Clarification on ITB Specifications

All questions regarding this ITB shall be submitted via email. Emailed questions and inquires will be accepted from any and all prospective Bidders in accordance with the terms and conditions of the ITB.

All questions shall be due on or before **Friday, March 16, 2018 at 5:00 P.M.** and should be addressed as follows:

Specification/Scope of Work questions emailed to bslizewski@a2gov.org
Bid Process and Compliance questions emailed to cspencer@a2gov.org

Any error, omissions or discrepancies in the specification discovered by a prospective contractor and/or service provider shall be brought to the attention of Brian Slizewski at the above email address after discovery as possible. Further, the contractor and/or service provide shall not be allowed to take advantage of errors, omissions or discrepancies in the specifications.

Addenda

If it becomes necessary to revise any part of the ITB, notice of the Addendum will be posted to Michigan Inter-governmental Trade Network (MITN) www.mitn.info and/or City of Ann Arbor web site www.A2gov.org for all parties to download.

Each Bidder must in its Bid, to avoid any miscommunications, acknowledge all addenda which it has received, but the failure of a Bidder to receive, or acknowledge receipt of; any addenda shall

not relieve the Bidder of the responsibility for complying with the terms thereof.

The City will not be bound by oral responses to inquiries or written responses other than written addenda.

Bid Submission

All Bids are due and must be delivered to the City of Ann Arbor Procurement Unit on or before **Wednesday, March 28, 2018 at 10:00 A.M.** Bids submitted late or via oral, telephonic, telegraphic, electronic mail or facsimile **will not** be considered or accepted.

Each Bidder must submit one (1) original Bid and **one (1)** Bid copy in a sealed envelope clearly marked: **ITB No. 4524, 2018 Water Main and Sanitary Sewer Projects.**

Bids must be addressed and delivered to:

City of Ann Arbor
Procurement Unit,
c/o Customer Services, 1st Floor
301 East Huron Street
Ann Arbor, MI 48107

All Bids received on or before the Due Date will be publicly opened and recorded immediately. No immediate decisions are rendered.

The following forms provided within this ITB Document must be included in submitted bids.

- **City of Ann Arbor Prevailing Wage Declaration of Compliance**
- **City of Ann Arbor Living Wage Ordinance Declaration of Compliance**
- **Vendor Conflict of Interest Disclosure Form**
- **City of Ann Arbor Non-Discrimination Ordinance Declaration of Compliance**

Bids that fail to provide these completed forms listed above upon bid opening will be rejected as non-responsive and will not be considered for award.

Hand delivered bids will be date/time stamped/signed by the Procurement Unit at the address above in order to be considered. Normal business hours are 8:00 a.m. to 5:00 p.m. Monday through Friday, excluding Holidays. The City will not be liable to any Bidder for any unforeseen circumstances, delivery or postal delays. Postmarking to the Due Date will not substitute for receipt of the Bid. Each Bidder is responsible for submission of their Bid.

Additional time for submission of bids past the stated due date and time will not be granted to a single Bidder; however, additional time may be granted to all Bidders when the City determines in its sole discretion that circumstances warrant it.

Award

The City intends to award a Contract(s) to the lowest responsible Bidder(s). On multi-divisional contracts, separate divisions may be awarded to separate Bidders. The City may also utilize alternatives offered in the Bid Forms, if any, to determine the lowest responsible Bidder on each division, and award multiple divisions to a single Bidder, so that the lowest total cost is achieved for the City. For unit price bids, the Contract will be awarded based upon the unit prices and the

lump sum prices stated by the bidder for the work items specified in the bid documents, with consideration given to any alternates selected by the City. If the City determines that the unit price for any item is materially different for the work item bid than either other bidders or the general market, the City, in its sole discretion, in addition to any other right it may have, may reject the bid as not responsible or non-conforming.

The acceptability of major subcontractors will be considered in determining if a Bidder is responsible. In comparing Bids, the City will give consideration to alternate Bids for items listed in the bid forms. All key staff and subcontractors are subject to the approval by the City.

Official Documents

The City of Ann Arbor officially distributes bid documents from the Procurement Unit or through the Michigan Intergovernmental Trade Network (MITN). Copies of the bid documents obtained from any other source are not Official copies. Addenda and other bid information will only be posted to these official distribution sites. If you obtained City of Ann Arbor Bid documents from other sources, it is recommended that you register on www.MITN.info and obtain an official Bid. Bidders do not need to be shown on the plan holders list provided by MITN to be considered an official plan holder.

Bid Security

Each bid must be accompanied by a certified check, or Bid Bond by a surety licensed and authorized to do business within the State of Michigan, in the amount of 5% of the total of the bid price.

Withdrawal of Bids

After the time of opening, no Bid may be withdrawn for the period of ninety (90) days

Contract Time

Time is of the essence in the performance of the work under this Contract. The available time for work under this Contract is indicated on page C-1, Article III of the Contract. If these time requirements can not be met, the Bidder must stipulate on Bid Form Section 3 - Time Alternate its schedule for performance of the work. Consideration will be given to time in evaluating bids.

Liquidated Damages

A liquidated damages clause, as given on page C-2, Article III of the Contract, provides that the Contractor shall pay the City as liquidated damages, and not as a penalty, a sum certain per day for each and every day that the Contractor may be in default of completion of the specified work, within the time(s) stated in the Contract, or written extensions.

Liquidated damages clauses, as given in the General Conditions, provide further that the City shall be entitled to impose and recover liquidated damages for breach of the obligations under Chapter 112 of the City Code.

The liquidated damages are for the non-quantifiable aspects of any of the previously identified events and do not cover actual damages that can be shown or quantified nor are they intended to preclude recovery of actual damages in addition to the recovery of liquidated damages.

Human Rights Information

All contractors proposing to do business with the City shall satisfy the contract compliance administrative policy adopted by the City Administrator in accordance with the Section 9:158 of the Ann Arbor City Code. Breach of the obligation not to discriminate as outlined in Section 5, beginning at page GC-2 shall be a material breach of the contract. Contractors are required to post a copy of Ann Arbor's Non-Discrimination Ordinance attached at all work locations where its employees provide services under a contract with the City.

Wage Requirements

Section 4, beginning at page GC-1, outlines the requirements for payment of prevailing wages and for payment of a "living wage" to employees providing service to the City under this contract. The successful bidder and its subcontractors must comply with all applicable requirements and provide proof of compliance.

Pursuant to Resolution R-16-469 all public improvement contractors are subject to prevailing wage and will be required to provide to the City payroll records sufficient to demonstrate compliance with the prevailing wage requirements. Use of the Prevailing Wage Form provided in the Appendix section or a City-approved equivalent will be required along with wage rate interviews.

For laborers whose wage level are subject to federal, state and/or local prevailing wage law the appropriate Davis-Bacon wage rate classification is identified based upon the work including within this contract. **The wage determination(s) current on the date 10 days before bids are due shall apply to this contract.** The U.S. Department of Labor (DOL) has provided explanations to assist with classification in the following resource link: www.wdol.gov.

For the purposes of this ITB the Construction Type of Heavy will apply.

Conflict Of Interest Disclosure

The City of Ann Arbor Purchasing Policy requires that prospective Vendors complete a Conflict of Interest Disclosure form. A contract may not be awarded to the selected Vendor unless and until the Procurement Unit and the City Administrator have reviewed the Disclosure form and determined that no conflict exists under applicable federal, state, or local law or administrative regulation. Not every relationship or situation disclosed on the Disclosure Form may be a disqualifying conflict. Depending on applicable law and regulations, some contracts may awarded on the recommendation of the City Administrator after full disclosure, where such action is allowed by law, if demonstrated competitive pricing exists and/or it is determined the award is in the best interest of the City. A copy of the Vendor Conflict of Interest Disclosure Form is attached.

Major Subcontractors

The Bidder shall identify on Bid Form Section 4 each major subcontractor it expects to engage for this Contract if the work to be subcontracted is 15% or more of the bid sum or over \$50,000, whichever is less. The Bidder also shall identify the work to be subcontracted to each major subcontractor. The Bidder shall not change or replace a subcontractor without approval by the City.

Debarment

Submission of a Bid in response to this ITB is certification that the Bidder is not currently debarred, suspended, proposed for debarment, and declared ineligible or voluntarily excluded from participation in this transaction by any State or Federal departments or agency. Submission is also agreement that the City will be notified of any changes in this status.

Disclosures

After bids are opened, all information in a submitter's bid is subjected to disclosure under the provisions of Michigan Public Act No. 442 of 1976, as amended (MCL 15.231 et seq.) known as the "Freedom of Information Act." The Freedom of Information Act also provides for the complete disclosure of contracts and attachments thereto except where specifically exempted.

Bid Protest

All Bid protests must be in writing and filed with the Purchasing Agent within five (5) business days of the award action. The bidder must clearly state the reasons for the protest. If a bidder contacts a City Service Area/Unit and indicates a desire to protest an award, the Service Area/Unit shall refer the bidder to the Purchasing Agent. The Purchasing Agent will provide the bidder with the appropriate instructions for filing the protest. The protest shall be reviewed by the City Administrator or designee whose decision shall be final.

Cost Liability

The City of Ann Arbor assumes no responsibility or liability for costs incurred by the Bidder prior to the execution of a contract with the City. By submitting a bid, a bidder agrees to bear all costs incurred or related to the preparation, submission and selection process for the bid.

Reservation of Rights

The City of Ann Arbor reserves the right to accept any bid or alternative bid proposed in whole or in part, to reject any or all bids or alternatives bids in whole or in part and to waive irregularity and/or informalities in any bid and to make the award in any manner deemed in the best interest of the City.

Idlefree Ordinance

The City of Ann Arbor adopted an idling reduction Ordinance that goes into effect July 1, 2017. The full text of the ordinance (including exemptions) can be found at: www.a2gov.org/idlefree.

Under the ordinance, No Operator of a Commercial Vehicle shall cause or permit the Commercial Vehicle to Idle:

- (a) For any period of time while the Commercial Vehicle is unoccupied; or
- (b) For more than 5 minutes in any 60-minute period while the Commercial Vehicle is occupied.

In addition, generators and other internal combustion engines are covered

(1) Excluding Motor Vehicle engines, no internal combustion engine shall be operated except when it is providing power or electrical energy to equipment or a tool that is actively in use.

INVITATION TO BID

City of Ann Arbor
Guy C. Larcom Municipal Building
Ann Arbor, Michigan 48107

Ladies and Gentlemen:

The undersigned, as Bidder, declares that this Bid is made in good faith, without fraud or collusion with any person or persons bidding on the same Contract; that this Bidder has carefully read and examined the bid documents, including City Nondiscrimination requirements and Declaration of Compliance Form, Living Wage requirements and Declaration of Compliance Form, Prevailing Wage requirements and Declaration of Compliance Form, Vendor Conflict of Interest Form, Notice of Pre-Bid Conference, Instructions to Bidders, Bid, Bid Forms, Contract, Bond Forms, General Conditions, Standard Specifications, Detailed Specifications, all Addenda, and the Plans (if applicable) and understands them. The Bidder declares that it conducted a full investigation at the site and of the work proposed and is fully informed as to the nature of the work and the conditions relating to the work's performance. The Bidder also declares that it has extensive experience in successfully completing projects similar to this one.

The Bidder acknowledges that it has not received or relied upon any representations or warrants of any nature whatsoever from the City of Ann Arbor, its agents or employees, and that this Bid is based solely upon the Bidder's own independent business judgment.

The undersigned proposes to perform all work shown on the plans or described in the bid documents, including any addenda issued, and to furnish all necessary machinery, tools, apparatus, and other means of construction to do all the work, furnish all the materials, and complete the work in strict accordance with all terms of the Contract of which this Bid is one part.

In accordance with these bid documents, and Addenda numbered _____, the undersigned, as Bidder, proposes to perform at the sites in and/or around Ann Arbor, Michigan, all the work included herein for the amounts set forth in the Bid Forms.

The Bidder declares that it has become fully familiar with the liquidated damage clauses for completion times and for compliance with City Code Chapter 112, understands and agrees that the liquidated damages are for the non-quantifiable aspects of non-compliance and do not cover actual damages that may be shown and agrees that if awarded the Contract, all liquidated damage clauses form part of the Contract.

The Bidder declares that it has become fully familiar with the provisions of Chapter 14, Section 1:320 (Prevailing wages) and Chapter 23 (Living Wage) of the Code of the City of Ann Arbor and that it understands and agrees to comply, to the extent applicable to employees providing services to the City under this Contract, with the wage and reporting requirements stated in the City Code provisions cited. Bidder certifies that the statements contained in the City Prevailing Wage and Living Wage Declaration of Compliance Forms are true and correct. Bidder further agrees that the cited provisions of Chapter 14 and Chapter 23 form a part of this Contract.

The Bidder declares that it has become familiar with the City Conflict of Interest Disclosure Form and certifies that the statement contained therein is true and correct.

The Bidder encloses a certified check or Bid Bond in the amount of 5% of the total of the Bid Price. The Bidder agrees both to contract for the work and to furnish the necessary Bonds and insurance documentation within 10 days after being notified of the acceptance of the Bid.

If this Bid is accepted by the City and the Bidder fails to contract and furnish the required Bonds and insurance documentation within 10 days after being notified of the acceptance of this Bid, then the Bidder shall be considered to have abandoned the Contract and the certified check or Bid Bond accompanying this Bid shall become due and payable to the City.

If the Bidder enters into the Contract in accordance with this Bid, or if this Bid is rejected, then the accompanying check or Bid Bond shall be returned to the Bidder.

In submitting this Bid, it is understood that the right is reserved by the City to accept any Bid, to reject any or all Bids, to waive irregularities and/or informalities in any Bid, and to make the award in any manner the City believes to be in its best interest.

SIGNED THIS _____ DAY OF _____, 201__.

Bidder's Name

Authorized Signature of Bidder

Official Address

(Print Name of Signer Above)

Telephone Number

Email Address for Award Notice

LEGAL STATUS OF BIDDER

(The Bidder shall fill out the appropriate form and strike out the other three.)

Bidder declares that it is:

* A corporation organized and doing business under the laws of the State of _____, for whom _____, bearing the office title of _____, whose signature is affixed to this Bid, is authorized to execute contracts.

NOTE: If not incorporated in Michigan, please attach the corporation's Certificate of Authority

• A limited liability company doing business under the laws of the State of _____, whom _____ bearing the title of _____ whose signature is affixed to this proposal, is authorized to execute contract on behalf of the LLC.

* A partnership, organized under the laws of the state of _____ and filed in the county of _____, whose members are (list all members and the street and mailing address of each) (attach separate sheet if necessary):

* An individual, whose signature with address, is affixed to this Bid: _____ (initial here)

Authorized Official

_____ **Date** _____, 201__

(Print) Name _____ Title _____

Company: _____

Address: _____

Contact Phone () _____ Fax () _____

Email _____

BID FORM

Section 1–Schedule of Prices

Project: 2018 Water Main and Sanitary Sewer Projects

File #: 2017-033 Bid #: 4524

<u>Item</u>	<u>Description</u>	<u>Unit</u>	<u>Estimated Quantity</u>	<u>Unit Price</u>	<u>Total Price</u>
GENERAL ITEMS					
130	Protective Fencing	LF	600	\$ _____	\$ _____
135	Tree Removal (8" and Larger Trees)	Each	7	\$ _____	\$ _____
201	General Conditions, Max. \$40,000	LS	1	\$ _____	\$ _____
202	Project Supervision, Max. \$25,000	LS	1	\$ _____	\$ _____
203	Minor Traffic Devices, Max. \$15,000	LS	1	\$ _____	\$ _____
204	Digital Audio Visual Coverage	LS	1	\$ _____	\$ _____
205	Certified Payroll Compliance and Reporting	LS	1	\$ _____	\$ _____
206	"No Parking" Signs	Each	72	\$ _____	\$ _____
207	Type III Lighted Barricade, Furn. & Oper.	Each	50	\$ _____	\$ _____
208	Lighted, High Intensity, Channelizing Device, 42 inch Furn. & Oper.	Each	120	\$ _____	\$ _____
209	Plastic Drum - Lighted, Furn. and Oper.	Each	490	\$ _____	\$ _____
210	Temporary Type B Signs	SF	1,100	\$ _____	\$ _____
211	Sign, Portable, Changeable Message, Furn. and Oper.	Each	4	\$ _____	\$ _____
212	Sidewalk Barricade	Each	40	\$ _____	\$ _____
213	Clean-Up & Restoration, Special	LS	1	\$ _____	\$ _____
214	Basketball Pole Assembly	Each	1	\$ _____	\$ _____
702	Inlet Filter	Each	24	\$ _____	\$ _____
703	Silt Fence	LF	500	\$ _____	\$ _____
TOTAL THIS PAGE (BF-1)				\$ _____	

BID FORM

Section 1–Schedule of Prices

Project: 2018 Water Main and Sanitary Sewer Projects

File #: 2017-033 Bid #: 4524

<u>Item</u>	<u>Description</u>	<u>Unit</u>	<u>Estimated Quantity</u>	<u>Unit Price</u>	<u>Total Price</u>
UTILITY GENERAL ITEMS					
140	Exploratory Excavation (0-10' deep)	Each	4	\$ _____	\$ _____
144	Exploratory Excavation Add'l Depth	VF	32	\$ _____	\$ _____
220	Adjust Structure Cover, Modified	Each	15	\$ _____	\$ _____
391	Pipe Undercut and Refill (Class II)	CY	100	\$ _____	\$ _____
392	Pipe Undercut and Refill (6A)	CY	100	\$ _____	\$ _____
563	Structure Covers	Each	32	\$ _____	\$ _____
567	Adjust Monument Box or Gate Valve Box	Each	2	\$ _____	\$ _____
SANITARY ITEMS					
230	Manhole Tap, 8 inch	Each	4	\$ _____	\$ _____
231	Sewer Lead, Video	Each	32	\$ _____	\$ _____
232	Sewer Lead, Connect	Each	32	\$ _____	\$ _____
305	SDR 26 PVC Pipe, 8", Trench Detail II	LF	2,000	\$ _____	\$ _____
335	SDR 26 PVC Wye, 8" x 6"	Each	32	\$ _____	\$ _____
350	SDR 26 PVC Riser, 6"	VF	300	\$ _____	\$ _____
353	SDR 26 PVC Service Lead, 6", Trench Detail II	LF	924	\$ _____	\$ _____
360	Type I Manhole (0-10' deep)	Each	15	\$ _____	\$ _____
361	Type I Manhole Add'l Depth	VF	75	\$ _____	\$ _____
362	Type II Manhole - 6 foot diameter (0-10' deep)	Each	1	\$ _____	\$ _____
363	Type II Manhole - 6 foot diameter - Add'l Depth	VF	10	\$ _____	\$ _____
370	Drop Connection, 8 inch	VF	24	\$ _____	\$ _____
385-S	Sanitary Pipe Abandonment or Removal	LF	950	\$ _____	\$ _____
386-S	Sanitary Structure Abandonment or Removal	Each	6	\$ _____	\$ _____
TOTAL THIS PAGE (BF-2)				\$ _____	\$ _____

BID FORM

Section 1–Schedule of Prices

Project: 2018 Water Main and Sanitary Sewer Projects

File #: 2017-033 Bid #: 4524

<u>Item</u>	<u>Description</u>	<u>Unit</u>	<u>Estimated Quantity</u>	<u>Unit Price</u>	<u>Total Price</u>
WATER MAIN ITEMS					
241	Fire Hydrant Assembly Abandonment or Removal	Each	1	\$ _____	\$ _____
242	6 inch Temporary Water Main Line Stop	Each	12	\$ _____	\$ _____
243	8 inch Temporary Water Main Line Stop	Each	2	\$ _____	\$ _____
400	8 inch, Class 50 DIP w/polywrap, Trench Detail I	LF	1,700	\$ _____	\$ _____
402	6 inch Class 50 DIP w/polywrap, Trench Detail I	LF	140	\$ _____	\$ _____
410	8" 90° Bend	Each	2	\$ _____	\$ _____
411	8" 45° Bend	Each	8	\$ _____	\$ _____
412	8" 22 1/2° Bend	Each	2	\$ _____	\$ _____
413	8" 11 1/4° Bend	Each	6	\$ _____	\$ _____
414	8" x 6" Reducer	Each	6	\$ _____	\$ _____
415	6" x 6" x 6" Tee	Each	7	\$ _____	\$ _____
416	8" x 8" x 8" Tee	Each	3	\$ _____	\$ _____
440	Fire Hydrant Assembly, including 8" x 6" reducer	Each	4	\$ _____	\$ _____
442	8" Gate Valve-in Box	Each	2	\$ _____	\$ _____
443	6" Gate Valve-in Box	Each	1	\$ _____	\$ _____
446	8" Gate Valve-in Well	Each	6	\$ _____	\$ _____
460	Excavate & Backfill for Water Service Tap and Lead	LF	1,000	\$ _____	\$ _____
481	Water Main Pipe Abandonment	LF	1,420	\$ _____	\$ _____
482	Gate Valve in Box Abandonment or Removal	Each	4	\$ _____	\$ _____
483	Gate Valve in Well Abandonment or Removal	Each	1	\$ _____	\$ _____
TOTAL THIS PAGE (BF-3)				\$ _____	_____

BID FORM

Section 1–Schedule of Prices

Project: 2018 Water Main and Sanitary Sewer Projects

File #: 2017-033 Bid #: 4524

<u>Item</u>	<u>Description</u>	<u>Unit</u>	<u>Estimated Quantity</u>	<u>Unit Price</u>	<u>Total Price</u>
STORM SEWER ITEMS				\$ _____	\$ _____
324	12" CL IV RCP Storm Sewer Pipe, Trench Detail I	LF	200	\$ _____	\$ _____
367	Single Inlet	Each	4	\$ _____	\$ _____
385-R	Storm Pipe Abandonment or Removal	LF	200	\$ _____	\$ _____
386-R	Storm Structure Abandonment or Removal	Each	4	\$ _____	\$ _____
PAVING ITEMS				\$ _____	\$ _____
261	Pavt, Rem	SY	8,100	\$ _____	\$ _____
262	Remove Concrete Curb or Curb & Gutter, Any Type	LF	2,000	\$ _____	\$ _____
263	Remove Concrete Sidewalk, Ramp and Drives, Any Thickness	SF	3,900	\$ _____	\$ _____
264	Maintenance Gravel	Ton	100	\$ _____	\$ _____
265	Subgrade Undercutting and Backfill - Type II, Modified	CY	100	\$ _____	\$ _____
266	Aggregate Base, 21AA, 8 inch, CIP	SY	8,700	\$ _____	\$ _____
267	Machine Grading, Modified	Sta	37	\$ _____	\$ _____
270	HMA, 5E3 - Pavement Leveling and Top Course	Ton	15	\$ _____	\$ _____
271	HMA, 3C - Pavement Base Course	Ton	670	\$ _____	\$ _____
272	HMA, LVSP - Pavement Leveling Course	Ton	660	\$ _____	\$ _____
273	HMA, LVSP - Pavement Top Course	Ton	630	\$ _____	\$ _____
274	HMA, 36A - Pavement Top Course	Ton	25	\$ _____	\$ _____
280	Concrete Curb or Curb & Gutter, Any Type	LF	200	\$ _____	\$ _____
281	Concrete Curb or Curb & Gutter, Any Type - High Early	LF	1,800	\$ _____	\$ _____
282	4" Concrete Sidewalk	SF	800	\$ _____	\$ _____
283	6" Concrete Sidewalk, Ramp	SF	200	\$ _____	\$ _____
TOTAL THIS PAGE (BF-4)				\$ _____	

BID FORM

Section 1–Schedule of Prices

Project: 2018 Water Main and Sanitary Sewer Projects

File #: 2017-033 Bid #: 4524

<u>Item</u>	<u>Description</u>	<u>Unit</u>	<u>Estimated Quantity</u>	<u>Unit Price</u>	<u>Total Price</u>
284	6" Concrete Sidewalk, Ramp, Drive Approach - High Early	SF	3,000	\$ _____	\$ _____
285	Concrete Type M Drive Opening - High Early	LF	100	\$ _____	\$ _____
286	Detectable Warning, Cast In Place	SF	40	\$ _____	\$ _____
591	Temporary Pavement Markings (Type R) 6" Black	LF	1,000	\$ _____	\$ _____
592	Temporary Pavement Markings (Type R) 4" Yellow	LF	1,000	\$ _____	\$ _____
593	Temporary Pavement Markings (Type R) 4" White	LF	1,000	\$ _____	\$ _____
594	Hot-Applied, Thermoplastic Pavement Marking, 4" White	LF	550	\$ _____	\$ _____
595	Hot-Applied, Thermoplastic Pavement Marking, 4" Yellow	LF	1,550	\$ _____	\$ _____
596	Hot-Applied, Thermoplastic Pavement Marking, 6" White	LF	250	\$ _____	\$ _____
597	Hot-Applied, Thermoplastic Pavement Marking, 24" White	LF	50	\$ _____	\$ _____
598	Hot-Applied, Thermoplastic Pavement Marking, 12" White	LF	80	\$ _____	\$ _____
TOTAL THIS PAGE (BF-5)				\$ _____	
TOTAL FROM PAGE BF-1:				\$ _____	
TOTAL FROM PAGE BF-2:				\$ _____	
TOTAL FROM PAGE BF-3:				\$ _____	
TOTAL FROM PAGE BF-4:				\$ _____	
TOTAL BASE BID:				\$ _____	

BID FORM

Section 2 - Material and Equipment Alternates

The Base Bid proposal price shall include materials and equipment selected from the designated items and manufacturers listed in the bidding documents. This is done to establish uniformity in bidding and to establish standards of quality for the items named.

If the Contractor wishes to quote alternate items for consideration by the City, it may do so under this Section. A complete description of the item and the proposed price differential must be provided. Unless approved at the time of award, substitutions where items are specifically named will be considered only as a negotiated change in Contract Sum.

<u>Item Number</u>	<u>Description</u>	<u>Add/Deduct Amount</u>
--------------------	--------------------	--------------------------

If the Bidder does not suggest any material or equipment alternate, the Bidder **MUST** complete the following statement:

For the work outlined in this request for bid, the bidder does NOT propose any material or equipment alternate under the Contract.

Signature of Authorized Representative of Bidder _____ Date _____

BID FORM

Section 3 - Time Alternate

If the Bidder takes exception to the time stipulated in Article III of the Contract, Time of Completion, page C-2, it is requested to stipulate below its proposed time for performance of the work. Consideration will be given to time in evaluating bids.

If the Bidder does not suggest any time alternate, the Bidder **MUST** complete the following statement:

For the work outlined in this request for bid, the bidder does NOT propose any time alternate under the Contract.

Signature of Authorized Representative of Bidder _____ Date _____

BID FORM

Section 4 - Major Subcontractors

For purposes of this Contract, a Subcontractor is anyone (other than the Contractor) who performs work (other than or in addition to the furnishing of materials, plans or equipment) at or about the construction site, directly or indirectly for or on behalf of the Contractor (and whether or not in privity of Contract with the Contractor), but shall not include any individual who furnishes merely the individual's own personal labor or services.

Contractor agrees that all subcontracts entered into by the Contractor shall contain similar wage provision to Section 4 of the General Conditions covering subcontractor's employees who perform work on this contract.

For the work outlined in these documents the Bidder expects to engage the following major subcontractors to perform the work identified:

<u>Subcontractor (Name and Address)</u>	<u>Work</u>	<u>Amount</u>
---	-------------	---------------

If the Bidder does not expect to engage any major subcontractor, the Bidder **MUST** complete the following statement:

For the work outlined in this request for bid, the bidder does NOT expect to engage any major subcontractor to perform work under the Contract.

Signature of Authorized Representative of Bidder _____ Date _____

SAMPLE STANDARD CONTRACT

If a contract is awarded, the selected contractor will be required to adhere to a set of general contract provisions which will become a part of any formal agreement. These provisions are general principles which apply to all contractors of service to the City of Ann Arbor such as the following:

CONTRACT

THIS AGREEMENT is made on the _____ day of _____, 201_, between the CITY OF ANN ARBOR, a Michigan Municipal Corporation, 301 East Huron Street, Ann Arbor, Michigan 48104 ("City") and _____ ("Contractor")

(An individual/partnership/corporation, include state of incorporation) (Address)

Based upon the mutual promises below, the Contractor and the City agree as follows:

ARTICLE I - Scope of Work

The Contractor agrees to furnish all of the materials, equipment and labor necessary; and to abide by all the duties and responsibilities applicable to it for the project titled [Insert Title of Bid and Bid Number] in accordance with the requirements and provisions of the following documents, including all written modifications incorporated into any of the documents, which are incorporated as part of this Contract:

Non-discrimination and Living Wage Declaration of Compliance Forms (if applicable)	General Conditions
Vendor Conflict of Interest Form	Standard Specifications
Prevailing Wage Declaration of Compliance Form (if applicable)	Detailed Specifications
Bid Forms	Plans
Contract and Exhibits	Addenda
Bonds	

ARTICLE II - Definitions

Administering Service Area/Unit means Public Services Area / Engineering Unit

Project means **ITB No. 4524, 2018 Water Main and Sanitary Sewer Projects**

ARTICLE III - Time of Completion

- (A) The work to be completed under this Contract shall begin immediately on the date specified in the Notice to Proceed issued by the City.
- (B) The entire work for this Contract shall be completed within one hundred and fifty (150) consecutive calendar days.
- (C) Failure to complete all the work within the time specified above, including any extension granted in writing by the Supervising Professional, shall obligate the Contractor to pay the City, as liquidated damages and not as a penalty, an amount equal to \$500 for each calendar day of delay in the completion of all the work. If any liquidated damages are unpaid by the Contractor, the City shall be entitled to deduct these unpaid liquidated damages from the monies due the Contractor.

The liquidated damages are for the non-quantifiable aspects of any of the previously identified events and do not cover actual damages that can be shown or quantified nor are they intended to preclude recovery of actual damages in addition to the recovery of liquidated damages.

ARTICLE IV - The Contract Sum

- (A) The City shall pay to the Contractor for the performance of the Contract, the unit prices as given in the Bid Form for the estimated bid total of:

_____ Dollars (\$_____)

- (B) The amount paid shall be equitably adjusted to cover changes in the work ordered by the Supervising Professional but not required by the Contract Documents. Increases or decreases shall be determined only by written agreement between the City and Contractor.

ARTICLE V - Assignment

This Contract may not be assigned or subcontracted any portion of any right or obligation under this contract without the written consent of the City. Notwithstanding any consent by the City to any assignment, Contractor shall at all times remain bound to all warranties, certifications, indemnifications, promises and performances, however described, as are required of it under this contract unless specifically released from the requirement, in writing, by the City.

ARTICLE VI - Choice of Law

This Contract shall be construed, governed, and enforced in accordance with the laws of the State of Michigan. By executing this agreement, the Contractor and the City agree to venue in a court of appropriate jurisdiction sitting within Washtenaw County for purposes of any action arising under this Contract. The parties stipulate that the venue referenced in this Contract is for convenience and waive any claim of non-convenience.

Whenever possible, each provision of the Contract will be interpreted in a manner as to be effective and valid under applicable law. The prohibition or invalidity, under applicable law, of any provision will not invalidate the remainder of the Contract.

ARTICLE VII - Relationship of the Parties

The parties of the Contract agree that it is not a Contract of employment but is a Contract to accomplish a specific result. Contractor is an independent Contractor performing services for the City. Nothing contained in this Contract shall be deemed to constitute any other relationship between the City and the Contractor.

Contractor certifies that it has no personal or financial interest in the project other than the compensation it is to receive under the Contract. Contractor certifies that it is not, and shall not become, overdue or in default to the City for any Contract, debt, or any other obligation to the City including real or personal property taxes. City shall have the right to set off any such debt against compensation awarded for services under this agreement.

ARTICLE VIII - Notice

All notices given under this Contract shall be in writing, and shall be by personal delivery or by certified mail with return receipt requested to the parties at their respective addresses as specified in the Contract Documents or other address the Contractor may specify in writing. Notice will be deemed given on the date when one of the following first occur: (1) the date of actual receipt; or (2) three days after mailing certified U.S. mail.

ARTICLE IX - Indemnification

To the fullest extent permitted by law, Contractor shall indemnify, defend and hold harmless the City, its officers, employees and agents harmless from all suits, claims, judgments and expenses including attorney’s fees resulting or alleged to result, in whole or in part, from any act or omission, which is in any way connected or associated with this Contract, by the Contractor or anyone acting on the Contractor’s behalf under this Contract. Contractor shall not be responsible to indemnify the City for losses or damages caused by or resulting from the City’s sole negligence. The provisions of this Article shall survive the expiration or earlier termination of this contract for any reason.

ARTICLE X - Entire Agreement

This Contract represents the entire understanding between the City and the Contractor and it supersedes all prior representations, negotiations, agreements, or understandings whether written or oral. Neither party has relied on any prior representations in entering into this Contract. No terms or conditions of either party’s invoice, purchase order or other administrative document shall modify the terms and conditions of this Contract, regardless of the other party’s failure to object to such form. This Contract shall be binding on and shall inure to the benefit of the parties to this Contract and their permitted successors and permitted assigns and nothing in this Contract, express or implied, is intended to or shall confer on any other person or entity any legal or equitable right, benefit, or remedy of any nature whatsoever under or by reason of this Contract. This Contract may be altered, amended or modified only by written amendment signed by the City and the Contractor.

FOR CONTRACTOR

By _____

Its: _____

FOR THE CITY OF ANN ARBOR

By _____
Christopher Taylor, Mayor

By _____
Jacqueline Beaudry, City Clerk

Approved as to substance

By _____
Howard S. Lazarus, City Administrator

By _____
Craig Hupy,
Public Services Area Administrator

Approved as to form and content

Stephen K. Postema, City Attorney

PERFORMANCE BOND

- (1) _____ of _____ (referred to as "Principal"), and _____, a corporation duly authorized to do business in the State of Michigan (referred to as "Surety"), are bound to the City of Ann Arbor, Michigan (referred to as "City"), for \$ _____, the payment of which Principal and Surety bind themselves, their heirs, executors, administrators, successors and assigns, jointly and severally, by this bond.
- (2) The Principal has entered a written Contract with the City dated _____, 201_, for: _____ and this bond is given for that Contract in compliance with Act No. 213 of the Michigan Public Acts of 1963, as amended, being MCL 129.201 et seq.
- (3) Whenever the Principal is declared by the City to be in default under the Contract, the Surety may promptly remedy the default or shall promptly:
- (a) complete the Contract in accordance with its terms and conditions; or
 - (b) obtain a bid or bids for submission to the City for completing the Contract in accordance with its terms and conditions, and upon determination by Surety of the lowest responsible bidder, arrange for a Contract between such bidder and the City, and make available, as work progresses, sufficient funds to pay the cost of completion less the balance of the Contract price; but not exceeding, including other costs and damages for which Surety may be liable hereunder, the amount set forth in paragraph 1.
- (4) Surety shall have no obligation to the City if the Principal fully and promptly performs under the Contract.
- (5) Surety agrees that no change, extension of time, alteration or addition to the terms of the Contract or to the work to be performed thereunder, or the specifications accompanying it shall in any way affect its obligations on this bond, and waives notice of any such change, extension of time, alteration or addition to the terms of the Contract or to the work, or to the specifications.

SIGNED AND SEALED this _____ day of _____, 201_.

(Name of Surety Company)

By _____
(Signature)

Its _____
(Title of Office)

Approved as to form:

Stephen K. Postema, City Attorney

(Name of Principal)

By _____
(Signature)

Its _____
(Title of Office)

Name and address of agent:

LABOR AND MATERIAL BOND

- (1) _____
of _____ (referred to as "Principal"), and _____, a corporation duly authorized to do business in the State of Michigan, (referred to as "Surety"), are bound to the City of Ann Arbor, Michigan (referred to as "City"), for the use and benefit of claimants as defined in Act 213 of Michigan Public Acts of 1963, as amended, being MCL 129.201 et seq., in the amount of \$ _____, for the payment of which Principal and Surety bind themselves, their heirs, executors, administrators, successors and assigns, jointly and severally, by this bond.
- (2) The Principal has entered a written Contract with the City, dated _____, 201_, for _____; and this bond is given for that Contract in compliance with Act No. 213 of the Michigan Public Acts of 1963 as amended;
- (3) If the Principal fails to promptly and fully repay claimants for labor and material reasonably required under the Contract, the Surety shall pay those claimants.
- (4) Surety's obligations shall not exceed the amount stated in paragraph 1, and Surety shall have no obligation if the Principal promptly and fully pays the claimants.

SIGNED AND SEALED this _____ day of _____, 201_

(Name of Surety Company)
By _____
(Signature)
Its _____
(Title of Office)

(Name of Principal)
By _____
(Signature)
Its _____
(Title of Office)

Approved as to form:

Stephen K. Postema, City Attorney

Name and address of agent:

GENERAL CONDITIONS

Section 1 - Execution, Correlation and Intent of Documents

The contract documents shall be signed in 2 copies by the City and the Contractor.

The contract documents are complementary and what is called for by any one shall be binding. The intention of the documents is to include all labor and materials, equipment and transportation necessary for the proper execution of the work. Materials or work described in words which so applied have a well-known technical or trade meaning have the meaning of those recognized standards.

In case of a conflict among the contract documents listed below in any requirement(s), the requirement(s) of the document listed first shall prevail over any conflicting requirement(s) of a document listed later.

(1) Addenda in reverse chronological order; (2) Detailed Specifications; (3) Standard Specifications; (4) Plans; (5) General Conditions; (6) Contract; (7) Bid Forms; (8) Bond Forms; (9) Bid.

Section 2 - Order of Completion

The Contractor shall submit with each invoice, and at other times reasonably requested by the Supervising Professional, schedules showing the order in which the Contractor proposes to carry on the work. They shall include the dates at which the Contractor will start the several parts of the work, the estimated dates of completion of the several parts, and important milestones within the several parts.

Section 3 - Familiarity with Work

The Bidder or its representative shall make personal investigations of the site of the work and of existing structures and shall determine to its own satisfaction the conditions to be encountered, the nature of the ground, the difficulties involved, and all other factors affecting the work proposed under this Contract. The Bidder to whom this Contract is awarded will not be entitled to any additional compensation unless conditions are clearly different from those which could reasonably have been anticipated by a person making diligent and thorough investigation of the site.

The Bidder shall immediately notify the City upon discovery, and in every case prior to submitting its Bid, of every error or omission in the bidding documents that would be identified by a reasonably competent, diligent Bidder. In no case will a Bidder be allowed the benefit of extra compensation or time to complete the work under this Contract for extra expenses or time spent as a result of the error or omission.

Section 4 - Wage Requirements

Under this Contract, the Contractor shall conform to Chapter 14 of Title I of the Code of the City of Ann Arbor as amended; which in part states "...that all craftsmen, mechanics and laborers employed directly on the site in connection with said improvements, including said employees of subcontractors, shall receive the prevailing wage for the corresponding classes of craftsmen,

mechanics and laborers, as determined by statistics for the Ann Arbor area compiled by the United States Department of Labor. At the request of the City, any contractor or subcontractor shall provide satisfactory proof of compliance with the contract provisions required by the Section.

Pursuant to Resolution R-16-469 all public improvement contractors are subject to prevailing wage and will be required to provide to the City payroll records sufficient to demonstrate compliance with the prevailing wage requirements. A sample Prevailing Wage Form is provided in the Appendix herein for reference as to what will be expected from contractors. Use of the Prevailing Wage Form provided in the Appendix section or a City-approved equivalent will be required along with wage rate interviews.

Where the Contract and the Ann Arbor City Ordinance are silent as to definitions of terms required in determining contract compliance with regard to prevailing wages, the definitions provided in the Davis-Bacon Act as amended (40 U.S.C. 278-a to 276-a-7) for the terms shall be used.

If the Contractor is a "covered employer" as defined in Chapter 23 of the Ann Arbor City Code, the Contractor agrees to comply with the living wage provisions of Chapter 23 of the Ann Arbor City Code. The Contractor agrees to pay those employees providing Services to the City under this Agreement a "living wage," as defined in Section 1:815 of the Ann Arbor City Code, as adjusted in accordance with Section 1:815(3); to post a notice approved by the City of the applicability of Chapter 23 in every location in which regular or contract employees providing services under this Agreement are working; to maintain records of compliance; if requested by the City, to provide documentation to verify compliance; to take no action that would reduce the compensation, wages, fringe benefits, or leave available to any employee or person contracted for employment in order to pay the living wage required by Section 1:815; and otherwise to comply with the requirements of Chapter 23.

Contractor agrees that all subcontracts entered into by the Contractor shall contain similar wage provision covering subcontractor's employees who perform work on this contract.

Section 5 - Non-Discrimination

The Contractor agrees to comply, and to require its subcontractor(s) to comply, with the nondiscrimination provisions of MCL 37.2209. The Contractor further agrees to comply with the provisions of Section 9:158 of Chapter 112 of Title IX of the Ann Arbor City Code, and to assure that applicants are employed and that employees are treated during employment in a manner which provides equal employment opportunity.

Section 6 - Materials, Appliances, Employees

Unless otherwise stipulated, the Contractor shall provide and pay for all materials, labor, water, tools, equipment, light, power, transportation, and other facilities necessary or used for the execution and completion of the work. Unless otherwise specified, all materials incorporated in the permanent work shall be new, and both workmanship and materials shall be of the highest quality. The Contractor shall, if required, furnish satisfactory evidence as to the kind and quality of materials.

The Contractor shall at all times enforce strict discipline and good order among its employees, and shall seek to avoid employing on the work any unfit person or anyone not skilled in the work assigned.

Adequate sanitary facilities shall be provided by the Contractor.

Section 7 - Qualifications for Employment

The Contractor shall employ competent laborers and mechanics for the work under this Contract. For work performed under this Contract, employment preference shall be given to qualified local residents.

Section 8 - Royalties and Patents

The Contractor shall pay all royalties and license fees. It shall defend all suits or claims for infringements of any patent rights and shall hold the City harmless from loss on account of infringement except that the City shall be responsible for all infringement loss when a particular process or the product of a particular manufacturer or manufacturers is specified, unless the City has notified the Contractor prior to the signing of the Contract that the particular process or product is patented or is believed to be patented.

Section 9 - Permits and Regulations

The Contractor must secure and pay for all permits, permit or plan review fees and licenses necessary for the prosecution of the work. These include but are not limited to City building permits, right-of-way permits, lane closure permits, right-of-way occupancy permits, and the like. The City shall secure and pay for easements shown on the plans unless otherwise specified.

The Contractor shall give all notices and comply with all laws, ordinances, rules and regulations bearing on the conduct of the work as drawn and specified. If the Contractor observes that the contract documents are at variance with those requirements, it shall promptly notify the Supervising Professional in writing, and any necessary changes shall be adjusted as provided in the Contract for changes in the work.

Section 10 - Protection of the Public and of Work and Property

The Contractor is responsible for the means, methods, sequences, techniques and procedures of construction and safety programs associated with the work contemplated by this contract. The Contractor, its agents or sub-contractors, shall comply with the "General Rules and Regulations for the Construction Industry" as published by the Construction Safety Commission of the State of Michigan and to all other local, State and National laws, ordinances, rules and regulations pertaining to safety of persons and property.

The Contractor shall take all necessary and reasonable precautions to protect the safety of the public. It shall continuously maintain adequate protection of all work from damage, and shall take all necessary and reasonable precautions to adequately protect all public and private property from injury or loss arising in connection with this Contract. It shall make good any damage, injury or loss to its work and to public and private property resulting from lack of reasonable protective precautions, except as may be due to errors in the contract documents, or caused by agents or employees of the City. The Contractor shall obtain and maintain sufficient insurance to cover damage to any City property at the site by any cause.

In an emergency affecting the safety of life, or the work, or of adjoining property, the Contractor is, without special instructions or authorization from the Supervising Professional, permitted to act at its discretion to prevent the threatened loss or injury. It shall also so act, without appeal, if authorized or instructed by the Supervising Professional.

Any compensation claimed by the Contractor for emergency work shall be determined by agreement or in accordance with the terms of Claims for Extra Cost - Section 15.

Section 11 - Inspection of Work

The City shall provide sufficient competent personnel for the inspection of the work.

The Supervising Professional shall at all times have access to the work whenever it is in preparation or progress, and the Contractor shall provide proper facilities for access and for inspection.

If the specifications, the Supervising Professional's instructions, laws, ordinances, or any public authority require any work to be specially tested or approved, the Contractor shall give the Supervising Professional timely notice of its readiness for inspection, and if the inspection is by an authority other than the Supervising Professional, of the date fixed for the inspection. Inspections by the Supervising Professional shall be made promptly, and where practicable at the source of supply. If any work should be covered up without approval or consent of the Supervising Professional, it must, if required by the Supervising Professional, be uncovered for examination and properly restored at the Contractor's expense.

Re-examination of any work may be ordered by the Supervising Professional, and, if so ordered, the work must be uncovered by the Contractor. If the work is found to be in accordance with the contract documents, the City shall pay the cost of re-examination and replacement. If the work is not in accordance with the contract documents, the Contractor shall pay the cost.

Section 12 - Superintendence

The Contractor shall keep on the work site, during its progress, a competent superintendent and any necessary assistants, all satisfactory to the Supervising Professional. The superintendent will be responsible to perform all on-site project management for the Contractor. The superintendent shall be experienced in the work required for this Contract. The superintendent shall represent the Contractor and all direction given to the superintendent shall be binding as if given to the Contractor. Important directions shall immediately be confirmed in writing to the Contractor. Other directions will be confirmed on written request. The Contractor shall give efficient superintendence to the work, using its best skill and attention.

Section 13 - Changes in the Work

The City may make changes to the quantities of work within the general scope of the Contract at any time by a written order and without notice to the sureties. If the changes add to or deduct from the extent of the work, the Contract Sum shall be adjusted accordingly. All the changes shall be executed under the conditions of the original Contract except that any claim for extension of time caused by the change shall be adjusted at the time of ordering the change.

In giving instructions, the Supervising Professional shall have authority to make minor changes in the work not involving extra cost and not inconsistent with the purposes of the work, but otherwise, except in an emergency endangering life or property, no extra work or change shall be made unless in pursuance of a written order by the Supervising Professional, and no claim for an addition to the Contract Sum shall be valid unless the additional work was ordered in writing.

The Contractor shall proceed with the work as changed and the value of the work shall be determined as provided in Claims for Extra Cost - Section 15.

Section 14 - Extension of Time

Extension of time stipulated in the Contract for completion of the work will be made if and as the

Supervising Professional may deem proper under any of the following circumstances:

- (1) When work under an extra work order is added to the work under this Contract;
- (2) When the work is suspended as provided in Section 20;
- (3) When the work of the Contractor is delayed on account of conditions which could not have been foreseen, or which were beyond the control of the Contractor, and which were not the result of its fault or negligence;
- (4) Delays in the progress of the work caused by any act or neglect of the City or of its employees or by other Contractors employed by the City;
- (5) Delay due to an act of Government;
- (6) Delay by the Supervising Professional in the furnishing of plans and necessary information;
- (7) Other cause which in the opinion of the Supervising Professional entitles the Contractor to an extension of time.

The Contractor shall notify the Supervising Professional within 7 days of an occurrence or conditions which, in the Contractor's opinion, entitle it to an extension of time. The notice shall be in writing and submitted in ample time to permit full investigation and evaluation of the Contractor's claim. The Supervising Professional shall acknowledge receipt of the Contractor's notice within 7 days of its receipt. Failure to timely provide the written notice shall constitute a waiver by the Contractor of any claim.

In situations where an extension of time in contract completion is appropriate under this or any other section of the contract, the Contractor understands and agrees that the only available adjustment for events that cause any delays in contract completion shall be extension of the required time for contract completion and that there shall be no adjustments in the money due the Contractor on account of the delay.

Section 15 - Claims for Extra Cost

If the Contractor claims that any instructions by drawings or other media issued after the date of the Contract involved extra cost under this Contract, it shall give the Supervising Professional written notice within 7 days after the receipt of the instructions, and in any event before proceeding to execute the work, except in emergency endangering life or property. The procedure shall then be as provided for Changes in the Work-Section 13. No claim shall be valid unless so made.

If the Supervising Professional orders, in writing, the performance of any work not covered by the contract documents, and for which no item of work is provided in the Contract, and for which no unit price or lump sum basis can be agreed upon, then the extra work shall be done on a Cost-Plus-Percentage basis of payment as follows:

- (1) The Contractor shall be reimbursed for all reasonable costs incurred in doing the work, and shall receive an additional payment of 15% of all the reasonable costs to cover both its indirect overhead costs and profit;
- (2) The term "Cost" shall cover all payroll charges for employees and supervision required under the specific order, together with all worker's compensation, Social Security, pension and retirement allowances and social insurance, or other regular payroll charges on same;

the cost of all material and supplies required of either temporary or permanent character; rental of all power-driven equipment at agreed upon rates, together with cost of fuel and supply charges for the equipment; and any costs incurred by the Contractor as a direct result of executing the order, if approved by the Supervising Professional;

- (3) If the extra is performed under subcontract, the subcontractor shall be allowed to compute its charges as described above. The Contractor shall be permitted to add an additional charge of 5% percent to that of the subcontractor for the Contractor's supervision and contractual responsibility;
- (4) The quantities and items of work done each day shall be submitted to the Supervising Professional in a satisfactory form on the succeeding day, and shall be approved by the Supervising Professional and the Contractor or adjusted at once;
- (5) Payments of all charges for work under this Section in any one month shall be made along with normal progress payments. Retainage shall be in accordance with Progress Payments-Section 16.

No additional compensation will be provided for additional equipment, materials, personnel, overtime or special charges required to perform the work within the time requirements of the Contract.

When extra work is required and no suitable price for machinery and equipment can be determined in accordance with this Section, the hourly rate paid shall be 1/40 of the basic weekly rate listed in the Rental Rate Blue Book published by Dataquest Incorporated and applicable to the time period the equipment was first used for the extra work. The hourly rate will be deemed to include all costs of operation such as bucket or blade, fuel, maintenance, "regional factors", insurance, taxes, and the like, but not the costs of the operator.

Section 16 - Progress Payments

The Contractor shall submit each month, or at longer intervals, if it so desires, an invoice covering work performed for which it believes payment, under the Contract terms, is due. The submission shall be to the City's Finance Department - Accounting Division. The Supervising Professional will, within 10 days following submission of the invoice, prepare a certificate for payment for the work in an amount to be determined by the Supervising Professional as fairly representing the acceptable work performed during the period covered by the Contractor's invoice. To insure the proper performance of this Contract, the City will retain a percentage of the estimate in accordance with Act 524, Public Acts of 1980. The City will then, following the receipt of the Supervising Professional's Certificate, make payment to the Contractor as soon as feasible, which is anticipated will be within 15 days.

An allowance may be made in progress payments if substantial quantities of permanent material have been delivered to the site but not incorporated in the completed work if the Contractor, in the opinion of the Supervising Professional, is diligently pursuing the work under this Contract. Such materials shall be properly stored and adequately protected. Allowance in the estimate shall be at the invoice price value of the items. Notwithstanding any payment of any allowance, all risk of loss due to vandalism or any damages to the stored materials remains with the Contractor.

In the case of Contracts which include only the Furnishing and Delivering of Equipment, the payments shall be; 60% of the Contract Sum upon the delivery of all equipment to be furnished, or in the case of delivery of a usable portion of the equipment in advance of the total equipment delivery, 60% of the estimated value of the portion of the equipment may be paid upon its delivery in advance of the time of the remainder of the equipment to be furnished; 30% of the Contract

Sum upon completion of erection of all equipment furnished, but not later than 60 days after the date of delivery of all of the equipment to be furnished; and payment of the final 10% on final completion of erection, testing and acceptance of all the equipment to be furnished; but not later than 180 days after the date of delivery of all of the equipment to be furnished, unless testing has been completed and shows the equipment to be unacceptable.

With each invoice for periodic payment, the Contractor shall enclose a Contractor's Declaration - Section 43, and an updated project schedule per Order of Completion - Section 2.

Section 17 - Deductions for Uncorrected Work

If the Supervising Professional decides it is inexpedient to correct work that has been damaged or that was not done in accordance with the Contract, an equitable deduction from the Contract price shall be made.

Section 18 - Correction of Work Before Final Payment

The Contractor shall promptly remove from the premises all materials condemned by the Supervising Professional as failing to meet Contract requirements, whether incorporated in the work or not, and the Contractor shall promptly replace and re-execute the work in accordance with the Contract and without expense to the City and shall bear the expense of making good all work of other contractors destroyed or damaged by the removal or replacement.

If the Contractor does not remove the condemned work and materials within 10 days after written notice, the City may remove them and, if the removed material has value, may store the material at the expense of the Contractor. If the Contractor does not pay the expense of the removal within 10 days thereafter, the City may, upon 10 days written notice, sell the removed materials at auction or private sale and shall pay to the Contractor the net proceeds, after deducting all costs and expenses that should have been borne by the Contractor. If the removed material has no value, the Contractor must pay the City the expenses for disposal within 10 days of invoice for the disposal costs.

The inspection or lack of inspection of any material or work pertaining to this Contract shall not relieve the Contractor of its obligation to fulfill this Contract and defective work shall be made good. Unsuitable materials may be rejected by the Supervising Professional notwithstanding that the work and materials have been previously overlooked by the Supervising Professional and accepted or estimated for payment or paid for. If the work or any part shall be found defective at any time before the final acceptance of the whole work, the Contractor shall forthwith make good the defect in a manner satisfactory to the Supervising Professional. The judgment and the decision of the Supervising Professional as to whether the materials supplied and the work done under this Contract comply with the requirements of the Contract shall be conclusive and final.

Section 19 - Acceptance and Final Payment

Upon receipt of written notice that the work is ready for final inspection and acceptance, the Supervising Professional will promptly make the inspection. When the Supervising Professional finds the work acceptable under the Contract and the Contract fully performed, the Supervising Professional will promptly sign and issue a final certificate stating that the work required by this Contract has been completed and is accepted by the City under the terms and conditions of the Contract. The entire balance found to be due the Contractor, including the retained percentage, shall be paid to the Contractor by the City within 30 days after the date of the final certificate.

Before issuance of final certificates, the Contractor shall file with the City:

- (1) The consent of the surety to payment of the final estimate;
- (2) The Contractor's Affidavit in the form required by Section 44.

In case the Affidavit or consent is not furnished, the City may retain out of any amount due the Contractor, sums sufficient to cover all lienable claims.

The making and acceptance of the final payment shall constitute a waiver of all claims by the City except those arising from:

- (1) unsettled liens;
- (2) faulty work appearing within 12 months after final payment;
- (3) hidden defects in meeting the requirements of the plans and specifications;
- (4) manufacturer's guarantees.

It shall also constitute a waiver of all claims by the Contractor, except those previously made and still unsettled.

Section 20 - Suspension of Work

The City may at any time suspend the work, or any part by giving 5 days notice to the Contractor in writing. The work shall be resumed by the Contractor within 10 days after the date fixed in the written notice from the City to the Contractor to do so. The City shall reimburse the Contractor for expense incurred by the Contractor in connection with the work under this Contract as a result of the suspension.

If the work, or any part, shall be stopped by the notice in writing, and if the City does not give notice in writing to the Contractor to resume work at a date within 90 days of the date fixed in the written notice to suspend, then the Contractor may abandon that portion of the work suspended and will be entitled to the estimates and payments for all work done on the portions abandoned, if any, plus 10% of the value of the work abandoned, to compensate for loss of overhead, plant expense, and anticipated profit.

Section 21 - Delays and the City's Right to Terminate Contract

If the Contractor refuses or fails to prosecute the work, or any separate part of it, with the diligence required to insure completion, ready for operation, within the allowable number of consecutive calendar days specified plus extensions, or fails to complete the work within the required time, the City may, by written notice to the Contractor, terminate its right to proceed with the work or any part of the work as to which there has been delay. After providing the notice the City may take over the work and prosecute it to completion, by contract or otherwise, and the Contractor and its sureties shall be liable to the City for any excess cost to the City. If the Contractor's right to proceed is terminated, the City may take possession of and utilize in completing the work, any materials, appliances and plant as may be on the site of the work and useful for completing the work. The right of the Contractor to proceed shall not be terminated or the Contractor charged with liquidated damages where an extension of time is granted under Extension of Time - Section 14.

If the Contractor is adjudged a bankrupt, or if it makes a general assignment for the benefit of creditors, or if a receiver is appointed on account of its insolvency, or if it persistently or repeatedly refuses or fails except in cases for which extension of time is provided, to supply enough properly skilled workers or proper materials, or if it fails to make prompt payments to subcontractors or for material or labor, or persistently disregards laws, ordinances or the instructions of the Supervising Professional, or otherwise is guilty of a substantial violation of any provision of the Contract, then the City, upon the certificate of the Supervising Professional that sufficient cause exists to justify

such action, may, without prejudice to any other right or remedy and after giving the Contractor 3 days written notice, terminate this Contract. The City may then take possession of the premises and of all materials, tools and appliances thereon and without prejudice to any other remedy it may have, make good the deficiencies or finish the work by whatever method it may deem expedient, and deduct the cost from the payment due the Contractor. The Contractor shall not be entitled to receive any further payment until the work is finished. If the expense of finishing the work, including compensation for additional managerial and administrative services exceeds the unpaid balance of the Contract Sum, the Contractor and its surety are liable to the City for any excess cost incurred. The expense incurred by the City, and the damage incurred through the Contractor's default, shall be certified by the Supervising Professional.

Section 22 - Contractor's Right to Terminate Contract

If the work should be stopped under an order of any court, or other public authority, for a period of 3 months, through no act or fault of the Contractor or of anyone employed by it, then the Contractor may, upon 7 days written notice to the City, terminate this Contract and recover from the City payment for all acceptable work executed plus reasonable profit.

Section 23 - City's Right To Do Work

If the Contractor should neglect to prosecute the work properly or fail to perform any provision of this Contract, the City, 3 days after giving written notice to the Contractor and its surety may, without prejudice to any other remedy the City may have, make good the deficiencies and may deduct the cost from the payment due to the Contractor.

Section 24 - Removal of Equipment and Supplies

In case of termination of this Contract before completion, from any or no cause, the Contractor, if notified to do so by the City, shall promptly remove any part or all of its equipment and supplies from the property of the City, failing which the City shall have the right to remove the equipment and supplies at the expense of the Contractor.

The removed equipment and supplies may be stored by the City and, if all costs of removal and storage are not paid by the Contractor within 10 days of invoicing, the City upon 10 days written notice may sell the equipment and supplies at auction or private sale, and shall pay the Contractor the net proceeds after deducting all costs and expenses that should have been borne by the Contractor and after deducting all amounts claimed due by any lien holder of the equipment or supplies.

Section 25 - Responsibility for Work and Warranties

The Contractor assumes full responsibility for any and all materials and equipment used in the construction of the work and may not make claims against the City for damages to materials and equipment from any cause except negligence or willful act of the City. Until its final acceptance, the Contractor shall be responsible for damage to or destruction of the project (except for any part covered by Partial Completion and Acceptance - Section 26). The Contractor shall make good all work damaged or destroyed before acceptance. All risk of loss remains with the Contractor until final acceptance of the work (Section 19) or partial acceptance (Section 26). The Contractor is advised to investigate obtaining its own builders risk insurance.

The Contractor shall guarantee the quality of the work for a period of one year. The Contractor shall also unconditionally guarantee the quality of all equipment and materials that are furnished and installed under the contract for a period of one year. At the end of one year after the Contractor's receipt of final payment, the complete work, including equipment and materials

furnished and installed under the contract, shall be inspected by the Contractor and the Supervising Professional. Any defects shall be corrected by the Contractor at its expense as soon as practicable but in all cases within 60 days. Any defects that are identified prior to the end of one year shall also be inspected by the Contractor and the Supervising Professional and shall be corrected by the Contractor at its expense as soon as practicable but in all cases within 60 days. The Contractor shall assign all manufacturer or material supplier warranties to the City prior to final payment. The assignment shall not relieve the Contractor of its obligations under this paragraph to correct defects.

Section 26 - Partial Completion and Acceptance

If at any time prior to the issuance of the final certificate referred to in Acceptance and Final Payment - Section 19, any portion of the permanent construction has been satisfactorily completed, and if the Supervising Professional determines that portion of the permanent construction is not required for the operations of the Contractor but is needed by the City, the Supervising Professional shall issue to the Contractor a certificate of partial completion, and immediately the City may take over and use the portion of the permanent construction described in the certificate, and exclude the Contractor from that portion.

The issuance of a certificate of partial completion shall not constitute an extension of the Contractor's time to complete the portion of the permanent construction to which it relates if the Contractor has failed to complete it in accordance with the terms of this Contract. The issuance of the certificate shall not release the Contractor or its sureties from any obligations under this Contract including bonds.

If prior use increases the cost of, or delays the work, the Contractor shall be entitled to extra compensation, or extension of time, or both, as the Supervising Professional may determine.

Section 27 - Payments Withheld Prior to Final Acceptance of Work

The City may withhold or, on account of subsequently discovered evidence, nullify the whole or part of any certificate to the extent reasonably appropriate to protect the City from loss on account of:

- (1) Defective work not remedied;
- (2) Claims filed or reasonable evidence indicating probable filing of claims by other parties against the Contractor;
- (3) Failure of the Contractor to make payments properly to subcontractors or for material or labor;
- (4) Damage to another Contractor.

When the above grounds are removed or the Contractor provides a Surety Bond satisfactory to the City which will protect the City in the amount withheld, payment shall be made for amounts withheld under this section.

Section 28 - Contractor's Insurance

- (1) The Contractor shall procure and maintain during the life of this Contract, including the guarantee period and during any warranty work, such insurance policies, including those set forth below, as will protect itself and the City from all claims for bodily injuries, death

or property damage which may arise under this Contract; whether the act(s) or omission(s) giving rise to the claim were made by the Contractor or by any subcontractor or anyone employed by them directly or indirectly. In the case of all contracts involving on-site work, the Contractor shall provide to the City, before the commencement of any work under this contract, certificates of insurance and other documentation satisfactory to the City demonstrating it has obtained the policies and endorsements required on behalf of itself, and when requested, any subcontractor(s). The certificates of insurance endorsements and/or copies of policy language shall document that the Contractor satisfies the following minimum requirements.

- (a) Worker's Compensation Insurance in accordance with all applicable state and federal statutes. Further, Employers Liability Coverage shall be obtained in the following minimum amounts:

Bodily Injury by Accident - \$500,000 each accident
Bodily Injury by Disease - \$500,000 each employee
Bodily Injury by Disease - \$500,000 each policy limit

- (b) Commercial General Liability Insurance equivalent to, as a minimum, Insurance Services Office form CG 00 01 07 98 or current equivalent. The City of Ann Arbor shall be named as an additional insured. There shall be no added exclusions or limiting endorsements specifically for the following coverages: Products and Completed Operations, Explosion, Collapse and Underground coverage or Pollution. Further there shall be no added exclusions or limiting endorsements which diminish the City's protections as an additional insured under the policy. The following minimum limits of liability are required:

\$1,000,000 Each occurrence as respect Bodily Injury Liability or Property
Damage Liability, or both combined.
\$2,000,000 Per Job General Aggregate
\$1,000,000 Personal and Advertising Injury
\$2,000,000 Products and Completed Operations Aggregate

- (c) Motor Vehicle Liability Insurance, including Michigan No-Fault Coverages, equivalent to, as a minimum, Insurance Services Office form CA 00 01 07 97 or current equivalent. Coverage shall include all owned vehicles, all non-owned vehicles and all hired vehicles. The City of Ann Arbor shall be named as an additional insured. There shall be no added exclusions or limiting endorsements which diminish the City's protections as an additional insured under the policy. Further, the limits of liability shall be \$1,000,000 for each occurrence as respects Bodily Injury Liability or Property Damage Liability, or both combined.

- (d) Umbrella/Excess Liability Insurance shall be provided to apply excess of the Commercial General Liability, Employers Liability and the Motor Vehicle coverage enumerated above, for each occurrence and for aggregate in the amount of \$1,000,000.

- (2) Insurance required under subsection (1)(b) and (1)(c) above shall be considered primary as respects any other valid or collectible insurance that the City may possess, including any self-insured retentions the City may have; and any other insurance the City does possess shall be considered excess insurance only and shall not be required to contribute with this insurance. Further, the Contractor agrees to waive any right of recovery by its insurer against the City.

- (3) Insurance companies and policy forms are subject to approval of the City Attorney, which

approval shall not be unreasonably withheld. Documentation must provide and demonstrate an unconditional 30 day written notice of cancellation in favor of the City of Ann Arbor. Further, the documentation must explicitly state the following: (a) the policy number; name of insurance company; name and address of the agent or authorized representative; name and address of insured; project name; policy expiration date; and specific coverage amounts; (b) any deductibles or self-insured retentions which shall be approved by the City, in its sole discretion; (c) that the policy conforms to the requirements specified Contractor shall furnish the City with satisfactory certificates of insurance and endorsements prior to commencement of any work. Upon request, the Contractor shall provide within 30 days a copy of the policy(ies) to the City. If any of the above coverages expire by their terms during the term of this Contract, the Contractor shall deliver proof of renewal and/or new policies and endorsements to the Administering Service Area/Unit at least ten days prior to the expiration date.

- (4) Any Insurance provider of Contractor shall be admitted and authorized to do business in the State of Michigan and shall carry and maintain a minimum rating assigned by A.M. Best & Company's Key Rating Guide of "A-" Overall and a minimum Financial Size Category of "V". Insurance policies and certificates issued by non-admitted insurance companies are not acceptable unless approved in writing by the City.
- (5) City reserves the right to require additional coverage and/or coverage amounts as may be included from time to time in the Detailed Specifications for the Project.
- (6) The provisions of General Condition 28 shall survive the expiration or earlier termination of this contract for any reason.

Section 29 - Surety Bonds

Bonds will be required from the successful bidder as follows:

- (1) A Performance Bond to the City of Ann Arbor for the amount of the bid(s) accepted;
- (2) A Labor and Material Bond to the City of Ann Arbor for the amount of the bid(s) accepted.

Bonds shall be executed on forms supplied by the City in a manner and by a Surety Company authorized to transact business in Michigan and satisfactory to the City Attorney.

Section 30 - Damage Claims

The Contractor shall be held responsible for all damages to property of the City or others, caused by or resulting from the negligence of the Contractor, its employees, or agents during the progress of or connected with the prosecution of the work, whether within the limits of the work or elsewhere. The Contractor must restore all property injured including sidewalks, curbing, sodding, pipes, conduit, sewers or other public or private property to not less than its original condition with new work.

Section 31 - Refusal to Obey Instructions

If the Contractor refuses to obey the instructions of the Supervising Professional, the Supervising Professional shall withdraw inspection from the work, and no payments will be made for work performed thereafter nor may work be performed thereafter until the Supervising Professional shall have again authorized the work to proceed.

Section 32 - Assignment

Neither party to the Contract shall assign the Contract without the written consent of the other. The Contractor may assign any monies due to it to a third party acceptable to the City.

Section 33 - Rights of Various Interests

Whenever work being done by the City's forces or by other contractors is contiguous to work covered by this Contract, the respective rights of the various interests involved shall be established by the Supervising Professional, to secure the completion of the various portions of the work in general harmony.

The Contractor is responsible to coordinate all aspects of the work, including coordination of, and with, utility companies and other contractors whose work impacts this project.

Section 34 - Subcontracts

The Contractor shall not award any work to any subcontractor without prior written approval of the City. The approval will not be given until the Contractor submits to the City a written statement concerning the proposed award to the subcontractor. The statement shall contain all information the City may require.

The Contractor shall be as fully responsible to the City for the acts and omissions of its subcontractors, and of persons either directly or indirectly employed by them, as it is for the acts and omissions of persons directly employed by it.

The Contractor shall cause appropriate provisions to be inserted in all subcontracts relative to the work to bind subcontractors to the Contractor by the terms of the General Conditions and all other contract documents applicable to the work of the subcontractors and to give the Contractor the same power to terminate any subcontract that the City may exercise over the Contractor under any provision of the contract documents.

Nothing contained in the contract documents shall create any contractual relation between any subcontractor and the City.

Section 35 - Supervising Professional's Status

The Supervising Professional has the right to inspect any or all work. The Supervising Professional has authority to stop the work whenever stoppage may be appropriate to insure the proper execution of the Contract. The Supervising Professional has the authority to reject all work and materials which do not conform to the Contract and to decide questions which arise in the execution of the work.

The Supervising Professional shall make all measurements and determinations of quantities. Those measurements and determinations are final and conclusive between the parties.

Section 36 - Supervising Professional's Decisions

The Supervising Professional shall, within a reasonable time after their presentation to the Supervising Professional, make decisions in writing on all claims of the City or the Contractor and on all other matters relating to the execution and progress of the work or the interpretation of the contract documents.

Section 37 - Storing Materials and Supplies

Materials and supplies may be stored at the site of the work at locations agreeable to the City unless specific exception is listed elsewhere in these documents. Ample way for foot traffic and drainage must be provided, and gutters must, at all times, be kept free from obstruction. Traffic on streets shall be interfered with as little as possible. The Contractor may not enter or occupy with agents, employees, tools, or material any private property without first obtaining written permission from its owner. A copy of the permission shall be furnished to the Supervising Professional.

Section 38 - Lands for Work

The Contractor shall provide, at its own expense and without liability to the City, any additional land and access that may be required for temporary construction facilities or for storage of materials.

Section 39 - Cleaning Up

The Contractor shall, as directed by the Supervising Professional, remove at its own expense from the City's property and from all public and private property all temporary structures, rubbish and waste materials resulting from its operations unless otherwise specifically approved, in writing, by the Supervising Professional.

Section 40 - Salvage

The Supervising Professional may designate for salvage any materials from existing structures or underground services. Materials so designated remain City property and shall be transported or stored at a location as the Supervising Professional may direct.

Section 41 - Night, Saturday or Sunday Work

No night or Sunday work (without prior written City approval) will be permitted except in the case of an emergency and then only to the extent absolutely necessary. The City may allow night work which, in the opinion of the Supervising Professional, can be satisfactorily performed at night. Night work is any work between 8:00 p.m. and 7:00 a.m. No Saturday work will be permitted unless the Contractor gives the Supervising Professional at least 48 hours but not more than 5 days notice of the Contractor's intention to work the upcoming Saturday.

Section 42 - Sales Taxes

Under State law the City is exempt from the assessment of State Sales Tax on its direct purchases. Contractors who acquire materials, equipment, supplies, etc. for incorporation in City projects are not likewise exempt. State Law shall prevail. The Bidder shall familiarize itself with the State Law and prepare its Bid accordingly. No extra payment will be allowed under this Contract for failure of the Contractor to make proper allowance in this bid for taxes it must pay.

Section 43

CONTRACTOR'S DECLARATION

I hereby declare that I have not, during the period _____, 20____, to _____, 20____, performed any work, furnished any materials, sustained any loss, damage or delay, or otherwise done anything in addition to the regular items (or executed change orders) set forth in the Contract titled _____, for which I shall ask, demand, sue for, or claim compensation or extension of time from the City, except as I hereby make claim for additional compensation or extension of time as set forth on the attached itemized statement. I further declare that I have paid all payroll obligations related to this Contract that have become due during the above period and that all invoices related to this Contract received more than 30 days prior to this declaration have been paid in full except as listed below.

There is/is not (Contractor please circle one and strike one as appropriate) an itemized statement attached regarding a request for additional compensation or extension of time.

Contractor

Date

By _____
(Signature)

Its _____
(Title of Office)

Past due invoices, if any, are listed below.

STANDARD SPECIFICATIONS

All work under this contract shall be performed in accordance with the Public Services Department Standard Specifications in effect at the date of availability of the contract documents stipulated in the Bid. All work under this Contract which is not included in these Standard Specifications, or which is performed using modifications to these Standard Specifications, shall be performed in accordance with the Detailed Specifications included in these contract documents.

Standard Specifications are available online:

<http://www.a2gov.org/departments/engineering/Pages/Engineering-and-Contractor-Resources.aspx>

**DETAILED SPECIFICATION
FOR
PROJECT SCHEDULE AND PAYMENT**

1 of 3

DESCRIPTION

Examination of Plans, Specifications, and Work Site: Bidders shall carefully examine the Bid Form, plans, specifications and the work site until the Bidder is satisfied as to all local conditions affecting the contract and the detailed requirements of construction. The submission of the bid shall be considered prima facie evidence that the Bidder has made such examination and is satisfied as to the conditions to be encountered in performing the work and all requirements of the contract.

The entire work under this Contract shall be completed in accordance with, and subject to, the scheduling requirements as outlined below, and all other requirements of the Contract Documents.

1. The Contractor shall begin the work of this project on or before **May 29, 2018**, and only upon receipt of the fully executed Contract and Notice to Proceed. Appropriate time extensions shall be granted if the Notice to Proceed is delayed beyond this date.
2. This contract requires sanitary sewer and/or water main work at six separate locations, and shall be completed sequentially as listed below. With the exception of setting up/removing traffic control devices, **the contractor may not perform any construction activities at more than two locations at the same time.**
 - 1) Stone School Road – Work consists of the installation of new sanitary sewer and associated work. Utility construction, including all appurtenances, shall be completed within **fourteen (14) consecutive calendar days** of the notice to proceed. The entire work at this location as required by this Contract, including the stabilization of all disturbed areas shall be completed within **twenty-eight (28) consecutive calendar days** of the Notice to Proceed. The contractor shall coordinate its removal of traffic control devices with the installation of devices by City Resurfacing Program contractor such that the lane closures and detour remain in place through both projects.
 - 2) Brookwood Place – Work shall commence at this location on the calendar day immediately following completion of utility construction at the Stone School Road location. Utility construction, including all appurtenances, shall be completed within **fourteen (14) consecutive calendar days** after commencing with the work. The entire work at this location as required by this Contract, including the stabilization of all disturbed areas, and the removal of any and all traffic control devices shall be completed within **twenty-eight (28) consecutive calendar days** after commencing with the work.
 - 3) Packard Road – Work shall commence at this location on the calendar day immediately following completion of utility construction at the Brookwood Place location. Utility construction, including all appurtenances, shall be completed within **seven (7) consecutive calendar days** after commencing with the work. The entire work at this location as required by this Contract, including the stabilization of all disturbed areas, and the removal of any and all traffic control devices shall be completed within **twenty-eight (21) consecutive calendar days** after commencing with the work.
 - 4) Sycamore Place – Work shall commence at this location within seven (7) calendar days following completion of utility construction at the Packard Road location. Utility construction, including all appurtenances, shall be completed within **fourteen (14) consecutive calendar**

**DETAILED SPECIFICATION
FOR
PROJECT SCHEDULE AND PAYMENT**

2 of 3

days after commencing with the work. The entire work at this location as required by this Contract, including the stabilization of all disturbed areas, and the removal of any and all traffic control devices shall be completed within **twenty-eight (28) consecutive calendar days** after commencing with the work.

- 5) Lafayette Road – Work shall commence at this location on the calendar day immediately following completion of utility construction at the Sycamore Place location. Utility construction, including all appurtenances, shall be completed within **fourteen (14) consecutive calendar days** after commencing with the work. The entire work at this location as required by this Contract, including the stabilization of all disturbed areas, and the removal of any and all traffic control devices shall be completed within **twenty-eight (28) consecutive calendar days** after commencing with the work.

- 6) Horman Court – Work shall commence at this location on the calendar day immediately following completion of utility construction at the Lafayette Rd location. Utility construction, including all appurtenances, shall be completed within **fourteen (28) consecutive calendar days** after commencing with the work. The entire work at this location as required by this Contract, including the stabilization of all disturbed areas, and the removal of any and all traffic control devices shall be completed within **twenty-eight (49) consecutive calendar days** after commencing with the work.

The above described project schedule is shown on the following table:

Project Area	Start Date	Utilities Completed		Restoration Completed	
		Days	Date	Days	Date
Stone School	Tue, 05/29/18	20	Mon, 06/18/18	14	Mon, 07/02/18
Brookwood	Mon, 06/18/18	14	Mon, 07/02/18	14	Mon, 07/16/18
Packard (Hikone)	Mon, 07/02/18	7	Mon, 07/09/18	14	Mon, 07/23/18
Sycamore	Mon, 07/16/18	14	Mon, 07/30/18	14	Mon, 08/13/18
Lafayette	Mon, 07/30/18	14	Mon, 08/13/18	14	Mon, 08/27/18
Horman/Forest	Mon, 08/13/18	28	Mon, 09/10/18	21	Mon, 10/01/18

The Contractor is expected to be furnished with two (2) copies of the Contract, for his/her execution, on or before **April 9, 2018**. The Contractor shall properly execute both copies of the Contract and return them, with the required Bonds and Insurance Certificate, to the City within **ten (10) days**. The Contractor shall not begin the work before the applicable date(s) as describes herein without approval from the Project Engineer, and in no case before the receipt of the fully executed Contract. City Council approval is expected on **April 16, 2018**.

Time is of the essence in the performance of the work of this contract. The Contractor is expected to mobilize sufficient personnel and equipment and work throughout all authorized hours to complete the project by the final completion date. Should the Contractor demonstrate that they must work on some Sundays in order to maintain the project schedule, they may do so between the hours of 9:00 a.m. and 5:00 p.m. with prior approval from the City. There will be no additional compensation due to the Contractor for work performed on Sundays.

**DETAILED SPECIFICATION
FOR
PROJECT SCHEDULE AND PAYMENT**

3 of 3

Prior to the start of any construction, the Contractor shall submit a detailed schedule of work for the Engineer's review and approval. Work shall not be started until a schedule is approved in writing by the Engineer. The proposed schedule must fully comply with the scheduling requirements contained in this Detailed Specification. The Contractor shall update the approved work schedule upon request by the Engineer and present it to the Engineer within seven days of said request.

The Engineer may delay or stop the work due to threatening weather conditions. The Contractor shall not be compensated for unused materials or downtime due to rain, or the threat of rain. The Contractor is solely responsible for repairing all damages to the work and to the site, including road infrastructures, road subgrades, and any adjacent properties, which are caused as a result of working in the rain.

The Contractor shall not work in the dark except as approved by the Engineer and only when lighting for night work is provided as detailed elsewhere in this contract. The Engineer may stop the work, or may require the Contractor to defer certain work to another day, if, in the Engineer's opinion, the work cannot be completed within the remaining daylight hours, or if inadequate daylight is present to either properly perform or inspect the work. The Contractor will not be compensated for unused materials or downtime, when delays or work stoppages are directed by the Engineer for darkness and/or inadequate remaining daylight reasons. The Contractor is solely responsible for repairing all damages to the work and to the site, including road infrastructures, road subgrades, and any adjacent properties, which are caused as a result of working in the dark.

Failure to complete all work as specified herein within the times specified herein, including time extensions granted thereto as determined by the Engineer, shall entitle the City to deduct from the payments due the Contractor, **\$500.00** in Liquidated Damages, and not as a penalty, for delays in the completion of the work for each and every calendar day beyond the "Calendar Days to Complete" for each sub-phase, as required by this Detailed Specification.

Liquidated Damages will be assessed until the required work is completed in the current construction season. If, with the Engineer's approval, work is extended beyond seasonal limitations, the assessment of Liquidated Damages will be discontinued until the work is resumed in the following construction season.

MEASUREMENT AND PAYMENT

If the construction contract is not completed within the specified calendar day period including any extensions of time granted thereto, at the sole discretion of the City of Ann Arbor, this Contract may be terminated with no additional compensation due to the Contractor, and the Contractor may be forbidden to bid on future City of Ann Arbor projects for a period of at least three (3) years. If the Engineer elects to terminate the Contract, contract items paid for on a Lump Sum basis shall be paid up to a maximum percentage equal to the percentage of the contract work that has been completed.

Costs for the Contractor to organize, coordinate, and schedule all of the work of the project, will not be paid for separately, but shall be included in the bid price of the Contract Item "General Conditions, Maximum, \$____"

**DETAILED SPECIFICATION
FOR
MAINTENANCE OF TRAFFIC**

1 of 2

DESCRIPTION

Traffic shall be maintained in accordance with the City of Ann Arbor Public Services Department Standard Specifications and as specified in Sections 104.11, 812, and 922 of the Michigan Department of Transportation (MDOT) 2012 Standard Specifications for Construction, the 2011 Michigan Manual of Uniform Traffic Control Devices (MMUTCD), and as described herein.

The Contractor shall furnish, erect, maintain and, upon completion of the work, remove all traffic control devices and barricade lights as required on the project for the safety and protection of local traffic. This includes, but is not limited to, temporary advance, regulatory, and warning signs; barricades and channelizing devices at intersections and on streets where traffic is to be maintained; barricades at the ends of the project and at right-of-way lines of intersecting streets, and traffic control devices for moving construction operations.

MATERIALS

The materials and equipment shall meet the requirements specified in the corresponding sections of the MDOT 2012 Standard Specifications for Construction and the 2011 MMUTCD.

Maintenance of Local Traffic

Unless otherwise indicated on the plans, all side roads shall not be closed to through traffic except during construction operations of short duration and only upon written approval of the Engineer.

Local access shall be maintained at all times for emergency vehicles, refuse pick-up, mail delivery, school buses, and ingress/egress to public and private properties.

Contractor must accommodate the safe access to the residential buildings and businesses located within construction area.

Driveways shall not be blocked for extended periods of time unless arrangements can be made with the affected property owner(s). When it becomes necessary to temporarily block driveways, the Contractor shall notify the affected property owners in advance to coordinate the work and allow sufficient time for vehicles to vacate from properties. It may be necessary to allow for vehicles to temporarily park in the roadway at locations that do not interfere with the Contractor's work. During these periods the owners of the respective vehicles must be available to, with proper notice, move their vehicles if it becomes necessary to accommodate the work.

At times, when it becomes necessary to temporarily obstruct local traffic during the performance of the work, the Contractor shall provide traffic regulator control in conformance with Chapter 6E of the MMUTCD, Sections 6E.01 thru 6E.08. A minimum of two traffic regulators are required. The cost of traffic regulator control shall be included in the contract pay item "Minor Traffic Control, Maximum \$_____".

A lane-closure permit shall be obtained by the Contractor from the Project Management Services Unit, at least 48 hours in advance of any proposed lane or street closing. No lane closures shall be permitted July 4, and during the Labor Day and Memorial Day weekends.

**DETAILED SPECIFICATION
FOR
MAINTENANCE OF TRAFFIC**

2 of 2

The hours of work on all Local streets are 7:00 a.m. to 8:00 p.m., Monday through Saturday, or as specified on the lane-closure permit. No equipment will be allowed in the street before or after these hours. Local streets may only be closed to through traffic (local access only) with written authorization of the Engineer. Work must be completed each day such that all streets are re-opened to through traffic by 8:00 p.m. unless otherwise specified, directed, or authorized in writing by the Engineer. All major changes in traffic control shall be made either between 9:30 a.m. and 3:30 p.m. or between 7:00 p.m. and 6:30 a.m. in order to minimize interference with rush-hour traffic. All traffic controls must be in-place and ready for traffic each day by 6:30 a.m. and 3:30 p.m.

The Contractor shall temporarily cover conflicting traffic and/or parking signs when directed by the Engineer.

The Contractor shall use quantities of dust palliative, maintenance aggregate, and cold patching/HMA mixtures for use as temporary base, surfacing, and dust control at utility crossings, side roads and driveways (wherever required to maintain traffic), and where directed by the Engineer to maintain local access. The cost for the use of dust palliative, maintenance aggregate, cold patch and/or hot mix asphalt 36A mixture, as required and directed by the Engineer for maintenance of traffic and local access, shall be included in contract pay item "General Conditions, Maximum, \$____", and it will not be paid for separately.

The work of maintaining and relocating existing warning, regulatory and/or guide signs; and of removing, salvaging and reinstalling existing signs and supports is included in the bid price for the contract pay item "Minor Traffic Control, Maximum \$____".

Mailboxes and newspaper boxes that are in the way of the construction shall be removed and reset immediately in a temporary location approved by the Engineer. Mail and paper delivery shall not be interrupted during the construction. Upon completion of the construction, all mailboxes and newspaper boxes, including their supports, shall be repositioned in their permanent locations as approved by the Engineer. This work shall be included the contract unit price for the contract pay item "General Conditions, Maximum, \$____", and it will not be paid for separately.

The Contractor shall perform the work of this Contract while maintaining traffic in accordance with the Contract Documents as specified herein. No traffic shall be allowed on newly placed asphalt surfaces until rolling has been satisfactorily completed and the surface has cooled sufficiently to prevent damage from traffic. This is to be accomplished by flag persons and by relocating traffic control devices to prevent traffic from entering the work area until such time that it can be safely maintained without damaging the new construction. The Contractor shall provide traffic regulators in sufficient number to maintain traffic as described herein, and to keep traffic off sections being surfaced, and provide for safe travel at all times as directed by the Engineer.

The Contractor shall furnish, erect, maintain, and upon completion of the work, remove any and all traffic control devices utilized on the project.

Each pressure distributor, paver and roller shall be equipped with at least one approved flasher light which shall be mounted on the equipment so as to give a warning signal ahead and behind.

**DETAILED SPECIFICATION
FOR
ITEM #200 – GENERAL CONDITIONS, MAXIMUM \$40,000**

1 of 2

DESCRIPTION

This item shall include all work described and required by the Plans and Specifications at each location for which no item of work is listed in the Bid Form, including but not limited to:

- Scheduling and organization of all work, subcontractors, suppliers, testing, inspection, surveying, and staking.
- Coordination of, and cooperation with, other contractors, agencies, departments, and utilities.
- Protection and maintenance of utilities.
- Placing, maintaining, and removing additional needed soil erosion and sedimentation controls that are not paid separately.
- Maintaining drainage.
- Maintaining driveways drive openings, sidewalks, bike paths, mail deliveries, and solid waste/recycle pick-ups. This includes the placement and maintenance of gravel in driveway openings as directed by the Engineer.
- Storing all materials and equipment off lawn areas.
- Temporary relocation and final replacement/re-setting of mailboxes.
- Site clean-up.
- Coordination efforts to furnish various HMA mixtures as directed by the Engineer
- Coordination efforts to furnish and operate various-size vehicles/equipment as directed by the Engineer
- Furnishing and operating vacuum-type street cleaning equipment a minimum of once per week or more frequently as directed by the Engineer
- Furnishing and operating vacuum-type utility structure cleaning equipment
- Furnishing and operating both vibratory plate and pneumatic-type (“pogo-stick”) compactors
- Furnishing and operating a backhoe during all work activities
- Furnishing and operating a jackhammer and air compressor during all work activities
- Noise and dust control
- Mobilization(s) and demobilization(s).
- Furnishing submittals and certifications for materials and supplies
- Disposing of excavated materials and debris - The Contractor shall dispose of, at the Contractor’s expense, all excavated material. Costs for this work will not be paid for separately.
- All miscellaneous and incidental items such as overhead, insurance, and permits.
- Meeting all requirements relating to Debarment Certification, Davis Bacon Act, and Disadvantaged Business Enterprise, and providing the necessary documentation.

Data pertaining to existing soil borings and pavement sections which are included in these Contract Documents are provided to help the Engineer and Contractor determine the soil conditions existing within the construction area. The City in no way guarantees existing conditions to be the same as shown in the data. The Contractor is solely responsible for any and all conclusions he/she may draw from the data.

**DETAILED SPECIFICATION
FOR
ITEM #201 – GENERAL CONDITIONS, MAXIMUM \$40,000**

2 of 2

MEASUREMENT AND PAYMENT

This item of work will be paid for on a pro rata basis at the time of each progress payment. Measurement will be based on the ratio between work completed during the payment period and the total contract amount. When all of the work of this Contract has been completed, the measurement of this item shall be 1.0 Lump Sum, minus any deductions incurred for inadequate performance as described herein. This amount will not be increased for any reason, including extensions of time, extras, and/or additional work.

The completed work as measured for this item of work will be paid for at the Contract Unit Price for the following Contract (Pay) Item:

PAY ITEM

General Conditions, Maximum \$40,000

PAY UNIT

Lump Sum

The unit price for this item of work shall include all labor, material, and equipment costs to perform all the work specified in the Standard Specifications and as modified by this Detailed Specification.

**DETAILED SPECIFICATION
FOR
ITEM #202 - PROJECT SUPERVISION, MAXIMUM \$25,000**

1 of 3

DESCRIPTION

The Contractor shall designate a full-time Project Supervisor to act as the Contractor's agent/representative, and to be responsible for scheduling and coordination of all subcontractors, suppliers, other governmental agencies, and all public and private utility companies.

The Project Supervisor shall not be an active crew member of the Contractor, shall not be an active member or employee of any subcontractor's work force, and shall not perform general or specialized labor tasks.

The Project Supervisor shall work exclusively on this project, and shall put forth his/her full effort into the organization and coordination of the work of this project.

Prior to the pre-construction meeting, the Contractor shall designate a proposed Project Supervisor by name, and shall furnish the City with a current, thorough, detailed summary of the proposed Project Supervisor's work history, outlining all previous supervisory experience on projects of a similar size and nature. The detailed work history shall include personal and professional references (names and phone numbers) of persons (previous owners or agents) who can attest to the qualifications and work history of the proposed Project Supervisor. Proposed candidates for Project Supervisor shall have a demonstrated ability to work harmoniously with the City, the public, subcontractors, and all other parties typically involved with work of this nature. The Supervising Professional will have the authority to reject a proposed Project Supervisor whom he/she considers unqualified.

The Project Supervisor shall be available 24 hours-per-day to provide proper supervision, coordination and scheduling of the project for the duration of the Contract. The Contractor shall furnish the City with telephone numbers of the Project Supervisor in order to provide 24 hour-per-day access during business and non-business hours, including weekends and holidays.

The Project Supervisor shall be equipped by the Contractor with a mobile telephone to provide the City with 24 hour-per-day access to him/her during daily construction activities, during transit to and from the construction site, and during all non-business hours including weekends and holidays.

The Project Supervisor shall be equipped with assistants as necessary to provide project supervision as specified herein, and in accordance with the Contract.

DUTIES AND RESPONSIBILITIES

The Project Supervisor work harmoniously with the City, the public, subcontractors, and all other parties typically involved with work of this nature.

The Project Supervisor shall have a thorough, detailed understanding and working knowledge of all construction practices and methods specified elsewhere herein, as well as the handling, placement, testing and inspection of aggregates, aggregate products, HMA concrete, and Portland cement concrete materials.

The Project Supervisor shall be responsible for all of the work of all of the Contractor's, subcontractors' and suppliers' work forces.

**DETAILED SPECIFICATION
FOR
ITEM #202 - PROJECT SUPERVISION, MAXIMUM \$25,000**

2 of 3

The Project Supervisor shall be responsible for proper and adequate maintenance (emissions, safety, and general operation) of all of the Contractor's, subcontractors' and suppliers' equipment and vehicles.

The Project Supervisor shall be responsible for the legal, proper and safe parking/storage of all of the Contractor's, subcontractors' and suppliers' equipment, work vehicles, and employee's vehicles.

The Project Supervisor shall schedule and coordinate the work of all parties involved in the project, including utility companies, testing agencies, governmental agencies, all City departments (such as Utilities and Transportation), and City inspectors.

The Project Supervisor shall coordinate and schedule the work of any independent survey crews that may be retained by the City to witness and reset existing and new geographic/benchmark monuments. Failure to have existing monuments witnessed and reset may result in delays to the Contractor's work. Costs for such delays will be the Contractor's sole responsibility.

The Project Supervisor shall coordinate and schedule both testing inspectors and City inspectors in a timely manner, to assure proper and timely testing and inspection of the work.

The Project Supervisor shall review the Inspector's Daily Reports (IDRs) for accuracy, and shall sign all IDRs on a daily basis as the representative of the Contractor. Items to be reviewed include descriptions, locations and measurements of quantities of work performed, workforce, equipment, and weather. The Project Supervisor shall also be responsible for its subcontractors' review and initialing of IDRs containing work items performed by each respective subcontractor.

The Project Supervisor shall submit to the Engineer, an updated, detailed schedule of the proposed work on a weekly basis, and an update of all proposed changes on a daily basis, all in accordance with the Detailed Specification for Project Schedule contained elsewhere herein.

The Project Supervisor shall schedule and chair a weekly progress meeting with the Engineer and all subcontractors to discuss the work. Upon the completion of each meeting, the Project Supervisor shall prepare and distribute, to all present, a written summary of the meeting's minutes. Those in attendance shall review the minutes and, if necessary, comment on any deficiencies or errors prior to or at the next scheduled progress meeting.

ADDITIONAL PERFORMANCE REQUIREMENTS

If, in the sole opinion of the Supervising Professional, the Project Supervisor is not adequately performing the duties as outlined in this Detailed Specification, the following system of notices will be given to the contractor with the associated penalties:

First Notice – A warning will be issued in writing to the contractor detailing the deficiencies in the Project Supervision. The contractor must respond within 7 calendar days in writing with a plan to correct the stated deficiencies. Failure to respond within 7 calendar days will result in the issuing of a second notice.

**DETAILED SPECIFICATION
FOR
ITEM #202 - PROJECT SUPERVISION, MAXIMUM \$25,000**

3 of 3

Second Notice – A second warning will be issued in writing to the contractor further detailing the deficiencies in the Project Supervision. The contractor must respond within 7 calendar days in writing with a plan to correct the stated deficiencies. Failure to respond within 7 calendar days will result in the issuing of a third notice. A deduction of 10% will be made from the original Project Supervision contract amount. At this time, the City reserves the right to meet with personnel with the necessary authority within the Contractor’s organization to discuss the deficiencies in the Project Supervision.

Third Notice – An additional deduction of 25% will be made from the original Project Supervision contract amount, and the Project Supervisor shall be removed from the project, and replaced immediately with another individual to be approved by the Supervising Professional.

Should, in the sole opinion of the Supervising Professional, the Project Supervisor fail to perform his/her duties and responsibilities as described herein to such a degree that the successful completion of the project is put in jeopardy, the above system of notices may be foregone, and the Contractor shall immediately replace the Project Supervisor upon receipt of written notice. Failure to provide adequate project supervision, as determined by the Engineer, shall be considered basis for the Supervising Professional to suspend work without extension of contract time or additional compensation.

MEASUREMENT AND PAYMENT

This item of work will be paid for on a pro rata basis at the time of each progress payment. Measurement will be based on the ratio between work completed during the payment period and the total contract amount. When all of the work of this Contract has been completed, the measurement of this item shall be 1.0 Lump Sum, minus any deductions incurred for inadequate performance as described herein. This amount will not be increased for any reason, including extensions of time, extras, and/or additional work.

The completed work as measured for this item of work will be paid for at the Contract Unit Price for the following Contract (Pay) Item:

<u>PAY ITEM</u>	<u>PAY UNIT</u>
Project Supervision, Maximum \$25,000	Lump Sum

The unit price for this item of work shall include all labor, material, and equipment costs to perform all the work specified in the City Standard Specifications and as modified by this Detailed Specification.

**DETAILED SPECIFICATION
FOR
ITEM #203 – MINOR TRAFFIC CONTROL, MAXIMUM \$15,000**

1 of 5

DESCRIPTION

The work shall include, but is not limited to the following:

- The furnishing and operating of miscellaneous signs, warning devices, traffic regulators, flags, paddles, and cones;
- The operation of additional signs furnished by the City;
- Furnishing and installing meter bags;
- Coordinating with the City to have meter heads removed and reinstalled;
- Maintaining pedestrian traffic;
- Temporarily covering traffic controls;
- Temporarily covering existing signs as directed;
- Any and all other miscellaneous and/or incidental items which are necessary to properly perform the work.

This work shall consist of protecting and maintaining vehicular and pedestrian traffic, in accordance with Sections 104.11 and 812 of the Michigan Department of Transportation (MDOT) 2012 Standard Specifications for Construction; Part 6 of the 2011 Edition of the Michigan Manual of Uniform Traffic Control Devices (MMUTCD); and the City of Ann Arbor Standard Specifications for Construction, except as modified herein.

MATERIALS, EQUIPMENT, AND CONSTRUCTION METHODS

Materials and equipment shall meet the requirements specified in the above designated sections of the MDOT 2012 Standard Specifications for Construction.

The Contractor shall maintain two-way traffic on major streets, access for local traffic on local streets, and keep all intersections open to traffic at all times, unless specifically authorized in writing by the Engineer.

The Contractor shall maintain traffic such that no vehicle shall be required to drive into active work areas. Patch areas which extend more than halfway across the roadway shall be removed and replaced so as to provide a minimum of half the pavement width at all times for maintaining traffic.

The Contractor shall keep all driveways open at all times, unless specifically authorized in writing by the Engineer.

The Contractor shall maintain pedestrian traffic at all times. For maintaining normal pedestrian traffic while performing sidewalk and driveway repair, Plastic Drum, High Intensity, Lighted shall be placed by the Contractor as directed by the Engineer. The Contractor, when directed by the Engineer, shall place ADA compliant pedestrian barricades, "Sidewalk Closed" and/or "Cross Here" signs. The cost shall be included in this pay item and will not be paid for separately.

All temporary traffic/pedestrian control devices furnished by the Contractor shall remain the property of the Contractor. The City shall not be responsible for stolen or damaged signs, barricades, barricade lights or other traffic maintenance items. The Contractor shall replace missing traffic control devices immediately, at no additional cost to the Contractor or City.

**DETAILED SPECIFICATION
FOR
ITEM #203 – MINOR TRAFFIC CONTROL, MAXIMUM \$15,000**

2 of 5

All existing signs, and signs erected by the City of Ann Arbor on this project shall be preserved, protected, and maintained by the Contractor. The City will repair any existing City owned signs, at the Contractor's expense, which are damaged by the Contractor during the work.

The Contractor shall obtain a Traffic Detour or Lane Closure Permit from the City's Project Management Services Unit, at least 48 hours in advance of any proposed lane or street closing.

Traffic on major streets should not be impacted between the hours of 7:00 a.m. to 9:00 a.m. and from 3:30 p.m. to 6:00 p.m. without written permission from the Engineer or as specified on the Lane Closure Permit. All major changes in traffic control shall be made either between 9:00 a.m. and 3:30 p.m. or between 7:00 p.m. and 6:30 a.m. in order to minimize interference with rush hour traffic. All traffic controls must be in place and ready for traffic each day by 6:30 a.m. and 3:30 p.m.

The hours of work on all local streets are 7:00 a.m. to 8:00 p.m., Monday through Saturday, or as specified on the Lane Closure Permit. No equipment will be allowed in the street before or after these hours. Local streets may only be closed to through traffic (local access only) with written authorization of the Engineer. Work must be completed each day such that all streets are re-opened to through traffic by 8:00 p.m. unless otherwise specified, directed, or authorized in writing by the Engineer.

The Contractor shall temporarily cover conflicting traffic and/or parking signs when directed by the Engineer.

Parking violation citations issued to the Contractor, subcontractor, and material suppliers including each of their respective employees shall be enforced under appropriate City Code.

The Contractor shall replace missing or damaged traffic control devices as directed by the Engineer. When traffic control devices have been damaged by, or due to, the negligence of the Contractor, its subcontractors or material suppliers, the traffic control devices shall be replaced at the Contractor's expense.

The work for Minor Traffic Control, Modified shall include: furnishing and operating of miscellaneous signs and warning devices; furnishing cones; operating additional signs furnished by the City throughout the life of the Contract; furnishing and operating pedestrian traffic control devices; maintaining a safe trench during all non-working hours; maintaining access to all drives; covering conflicting existing signs and removal of these covers; and any and all other miscellaneous and/or incidental items which are necessary to properly perform the work.

Where there is metered parking, the Contractor shall either rent and install meter bags, or, with the Engineer's authorization, coordinate with the City Field Services to have meter heads removed and reinstalled.

The Contractor shall maintain vehicular and pedestrian traffic during the work by the use of traffic regulators, channelizing devices and signs as necessary, as directed by the Engineer, and in accordance with 2011 Edition of the MMUTCD. Typical applications for maintaining pedestrian traffic in accordance with the 2011 Edition of the MMUTCD are included in this detailed specification.

**DETAILED SPECIFICATION
FOR
ITEM #203 – MINOR TRAFFIC CONTROL, MAXIMUM \$15,000**

3 of 5

In order to maintain areas of on-street parking available for residents, the Engineer may direct the contractor to cover and uncover temporary “No Parking” signs within the project limits multiple times throughout the course of the project. Such repeated covering and uncovering of signs shall be included in this item of work and shall not be paid for separately.

MEASUREMENT AND PAYMENT

All temporary traffic/pedestrian control devices furnished by the Contractor shall remain the property of the Contractor. The City shall not be responsible for stolen or damaged signs, barricades, barricade lights or other traffic maintenance items. The Contractor shall replace missing traffic control devices immediately, at no additional cost to the City.

Costs for transporting barricades and other temporary traffic control devices shall be included in the bid prices for the individual items of work.

Minor Traffic Control, Maximum \$15,000 will be paid for on a pro rata basis with each progress payment. Measurement will be based on the ratio between work completed during the payment period and the total contract amount. When all of the work of this Contract has been completed, the measurement of this item shall be 1.0 Lump Sum minus any deductions incurred for inadequate performance as described herein. This amount will not be increased for any reason, including extensions of time, extras, and/or additional work.

The completed work as measured for these items of work will be paid for at the Contract Unit Price for the following Contract (Pay) Items:

PAY ITEM

PAY UNIT

Minor Traffic Control, Maximum \$15,000

Lump Sum

The unit price for this item of work shall include all labor, material, and equipment costs to perform all the work specified in the MDOT and City Standard Specifications for Construction, and as modified by this Detailed Specification.

**DETAILED SPECIFICATION
FOR
ITEM #203 – MINOR TRAFFIC CONTROL, MAXIMUM \$15,000**

4 of 5

2009 Edition

Page 689 (MI)



Figure 6H-28. Sidewalk Detour or Diversion (TA-28)

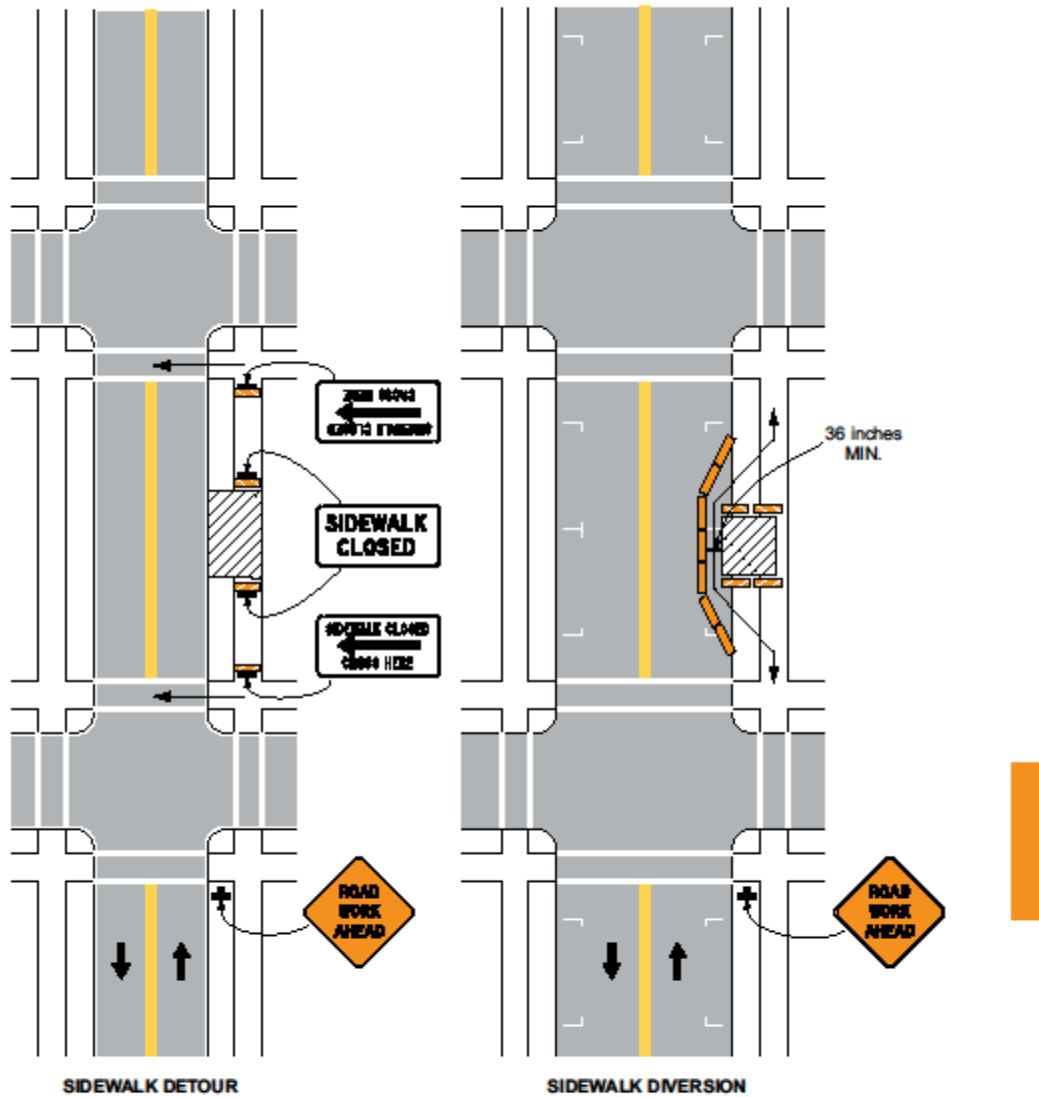

Typical Application 28

Note: See Tables 6H-2 and 6H-3 for the meaning of the symbols and/or letter codes used in this figure.

December 2009

Sect. 6H.01

**DETAILED SPECIFICATION
FOR
ITEM #204 – DIGITAL AUDIO VISUAL TAPE COVERAGE**

1 of 3

DESCRIPTION

This work shall include digital audiovisual record of the physical, structural, and aesthetic conditions of the construction site and adjacent areas as provided herein. This work will be performed for the entire project limits prior to the start of construction.

The audio-visual filming shall be:

1. Of professional quality, providing a clear and accurate audio and visual record of existing conditions.
2. Prepared within the one (1) week period immediately prior to the start of construction.
3. Furnished to the Engineer prior to bringing any materials or equipment within the areas described in this Detailed Specification.
4. Carried-out under the supervision of the Engineer.

The Contractor shall furnish one (1) copy of the completed audiovisual record to the Engineer. An index of the footage shall be included, which will enable any particular area of the project to be easily found. **This includes indexing the files according to street and Station number as applicable.** The Contractor shall retain a second copy of the audiovisual record for his/her own use.

Any portion of the film determined by the Engineer to be unacceptable for the documentation of existing conditions shall be filmed again at the Contractor's sole expense prior to mobilizing onto the site.

PRODUCTION

The audio-visual filming shall be completed in accordance with the following minimum requirements:

1. DVD Format, No Editing - The filming shall be done in color using equipment that allows audio and visual information to be recorded. Splicing or editing of the tape shall not be allowed and the speed and electronics of the videotaping equipment and DVD shall be equal to that which is standard to the videotaping industry.
2. Perspective / Speed / Pan / Zoom - To ensure proper perspective, the distance from the ground to the camera lens shall not be less than 10 feet and the filming must proceed in the general direction of travel at a speed not to exceed 48 feet per minute. Pan and zoom rates shall be controlled sufficiently so that playback will ensure quality of the object viewed.
3. Display - The recording equipment shall have transparent time, date stamp and digital annotation capabilities. The final copies of the tape shall continuously and simultaneously display the time (hours:minutes:seconds) and the date (month/date/year) in the upper left-hand corner of the frame. Accurate project stationing, where applicable, shall be included in the lower half of the frame in standard format (i.e. 1+00). Below the stationing periodic information is to be shown, including project name, name of area shown, street address, direction of travel, viewing direction, etc. If in the event, the stationing has not been established on-site, refer to the plans and approximate the proposed stationing.

**DETAILED SPECIFICATION
FOR
ITEM #204 – DIGITAL AUDIO VISUAL TAPE COVERAGE**

2 of 3

4. Audio Commentary / Visual Features. Locations relative to project limits and landmarks must be identified by both audio and video means at intervals no longer than 100 feet along the filming route. Additional audio commentary shall be provided as necessary during filming to describe streets, buildings, landmarks, and other details, which will enhance the record of existing conditions.
5. Visibility / Ground Cover - The filming shall be performed during a time of good visibility. Filming shall not be performed during periods of precipitation or when snow, leaves, or other natural debris obstruct the area being filmed. The Contractor shall notify the Engineer in writing in the event that the weather or snow cover is anticipated to cause a delay in filming.

COVERAGE

The audio-visual film coverage shall include the following:

1. General Criteria - This general criteria shall apply to all filming and shall include all areas where construction activities will take place or where construction vehicles or equipment will be operated or parked and or where materials will be stored. The filming shall extend an additional 50 feet outside of all areas. The filming shall include all significant, existing man-made and natural features such as driveways, sidewalks, utility covers, utility markers, utility poles, other utility features, traffic signal structures and features, public signs, private signs, fences, landscaping, trees, shrubs, other vegetation, and other similar or significant features.
2. Other Areas - The Contractor shall film at his sole expense other areas where, in his/her opinion, the establishment of a record of existing conditions is warranted. The Contractor shall notify the Engineer in writing of such areas.

The Engineer may direct the filming of other minor areas not specified herein at the Contractor's sole expense.

AUDIOVISUAL FILMING SERVICES

The following companies are known to be capable of providing the filming services required by this Detailed Specification and shall be utilized, unless the Contractor receives prior written approval from the Engineer to utilize another company of comparable or superior qualifications.

Construction Video Media
Midwest Company
Topo Video, Inc.
Video Media Corp.

**DETAILED SPECIFICATION
FOR
ITEM #204 – DIGITAL AUDIO VISUAL TAPE COVERAGE**

3 of 3

MEASUREMENT AND PAYMENT

The completed work as measured for these items of work will be paid for at the Contract Unit Prices for the following Contract (Pay) Items:

PAY ITEM

PAY UNIT

Digital Audio Visual Coverage

Lump Sum

Audiovisual Tape Coverage shall include all labor, equipment, and materials required to perform the filming and to provide the finished video the Engineer. The unit price includes filming the entire project limits, for each and every project location, as described above.

**DETAILED SPECIFICATION
FOR
ITEM #205 – CERTIFIED PAYROLL COMPLIANCE AND REPORTING**

1 of 2

DESCRIPTION

This specification covers all administrative requirements, payroll reporting procedures to be followed by Contractors performing work on City-sponsored public improvements projects, and all other miscellaneous and incidental costs associated with complying with the applicable sections of the City of Ann Arbor Code of Ordinances with regard to payment of prevailing wages and its Prevailing Wage Compliance policy.

This specification is not intended to include the actual labor costs associated with the payment of prevailing wages as required. Those costs should be properly incorporated in all other items of work bid.

GENERAL

The Contractor is expected to comply with all applicable sections of Federal and State prevailing wage laws, duly promulgated regulations, the City of Ann Arbor Code of Ordinances, and its Prevailing Wage Compliance Policy as defined within the contract documents. The Contractor shall provide the required certified payrolls, city-required declarations, and reports requested elsewhere in the contract documents within the timeline(s) stipulated therein.

The Contractor shall also provide corrected copies of any submitted documents that are found to contain errors, omissions, inconsistencies, or other defects that render the report invalid. The corrected copies shall be provided when requested by the Supervising Professional.

The Contractor shall also attend any required meetings as needed to fully discuss and ensure compliance with the contract requirements regarding prevailing wage compliance. The Contractor shall require all employees engaged in on-site work to participate in, provide the requested information to the extent practicable, and cooperate in the interview process. The City of Ann Arbor will provided the needed language interpreters in order to perform wage rate interviews or other field investigations as needed.

Certified Payrolls may be submitted on City-provided forms or forms used by the Contractor, as long as the Contractor's forms contain all required payroll information. If the Contractor elects to provide their own forms, the forms shall be approved by the Supervising Professional prior to the beginning of on-site work.

UNBALANCED BIDDING

The City of Ann Arbor will examine the submitted cost for this item of work prior to contract award. If the City determines, in its sole discretion, that the costs bid by the Contractor for complying with the contract requirements are not reasonable, accurately reported, or may contain discrepancies, the City reserves the right to request additional documentation that fully supports and justifies the price as bid. Should the submitted information not be determined to be reasonable or justify the costs, the City reserves the right to pursue award of the contract to the second low bidder without penalty or prejudice to any other remedies that it may have or may elect to exercise with respect to the original low-bidder.

The Contract Completion date will not be extended as a result of the City's investigation of the as-bid amount for this item of work, even if the anticipated contract award date must be adjusted. The only exception will be if the Contractor adequately demonstrates that their costs were appropriate and justifiable. If so, the City will adjust the contract completion date by the number of calendar days commensurate with the length of the investigation, if the published Notice to Proceed date of the work cannot be met. The contract unit prices for all other items of work will not be adjusted regardless of an adjustment of the contract completion date being made.

**DETAILED SPECIFICATION
FOR
ITEM #205 – CERTIFIED PAYROLL COMPLIANCE AND REPORTING**

2 of 2

MEASUREMENT AND PAYMENT

The completed work as measured for this item of work will be paid for at the Contract Unit Price for the following Contract (Pay) Item:

PAY ITEM

Certified Payroll Compliance and Reporting

PAY UNIT

Lump Sum

The unit price for this item of work shall include all supervisory, accounting, administrative, and equipment costs needed to monitor and perform all work related to maintaining compliance with the tasks specified in this Detailed Specification, the City of Ann Arbor Code of Ordinances, its Prevailing Wage Compliance policy and the applicable Federal and State laws.

Payment for this work will be made with each progress payment, on a pro-rata basis, based on the percentage of construction completed. When all of the work of this contract has been completed, the measurement of this item shall be 1.0 times the Lump Sum bid amount. This amount will not be increased for any reason, including extensions of time, extra work, and/or adjustments to existing items of work.

**DETAILED SPECIFICATION
FOR
ITEM #206 – “NO PARKING” SIGN**

DESCRIPTION

This work shall consist of installing, maintaining and removing of "No Parking" signs and posts as outlined herein and as referenced on the plans. "No Parking" signs shall be installed in accordance with the Public Services Department Standard Specifications and the 2011 Michigan Manual of Uniform Traffic Control Devices (MMUTCD).

MATERIAL

All materials for this work shall conform to the requirements of the Public Services Department Standard Specifications.

CONSTRUCTION METHODS

Prior to the commencement of any construction activity, the Contractor shall place “No Parking” signs as directed by the Engineer. The Contractor shall obtain a permit for “Temporary Permission of Reserve Parking Lane for Work Related Purposes” from the City’s Project Management Services Unit. This permit shall be obtained a minimum of 5 business days prior to the posting of “No Parking” signs.

The City will furnish "No Parking" signs to the Contractor at no cost. The Contractor shall furnish the signposts and shall securely bolt the signs to the signposts as directed by the Engineer. The Contractor shall install the signposts at least two feet deep into the ground, and there shall be a minimum of six feet and maximum of seven feet of clearance maintained between the bottom of the sign and the ground. The signs are to be placed at intervals no more than 150 feet and as necessary to eliminate parking in the construction area.

The installation of "No Parking" signs shall be in accordance with the permit. "No Parking" signs shall be installed by the Contractor, as directed by the Engineer, at least 48 hours prior to the proposed start-of-work/enforcement date. "No Parking" signs shall be covered by the Contractor, thereby allowing on-street parking, until between 48 and 24 hours prior to the start of the work. "No Parking" signs shall be covered by the Contractor whenever there is no work being performed for a period of time longer than 72 hours. "No Parking" signs shall be returned to the City upon the completion of work. The cost of unreturned signs will be back charged to the Contractor.

MEASUREMENT AND PAYMENT

The unit price for this item of work shall include all labor, material, and equipment costs to perform all the work specified in the Standard Specifications and as modified by this Detailed Specification.

PAY ITEM

PAY UNIT

“No Parking” Sign

Each

"No Parking" signs will be measured as the maximum number installed on each street at any one time. The unit price includes the removal and return of "No Parking" signs to the City upon completion of the project. The Contractor shall be back charged for the replacement costs for damaged or unreturned signs.

**DETAILED SPECIFICATION
FOR
ITEM #207 –TYPE III LIGHTED BARRICADE, FURN & OPER
ITEM #208 – 42 INCH LIGHTED CHANNELIZING DEVICE, FURN & OPER
ITEM #209 – PLASTIC DRUM, LIGHTED, FURN & OPER
ITEM #210 – TEMPORARY TYPE B SIGNS, FURN & OPER
ITEM #211 –PORTABLE CHANGEABLE MESSAGE SIGN, FURN & OPER
ITEM #212 – SIDEWALK BARRICADE, FURN & OPER**

1 of 2

DESCRIPTION

This work shall consist of protecting and maintaining vehicular and pedestrian traffic in accordance with Sections 140.11, 812, and 922 of the Michigan Department of Transportation (MDOT) 2012 Standard Specifications for Construction; Part 6 of the 2011 Edition of the Michigan Manual of Uniform Traffic Control Devices (MMUTCD); and the City of Ann Arbor Standard Specifications for Construction, except as modified herein.

MATERIALS, EQUIPMENT, AND CONSTRUCTION METHODS

Materials and equipment shall meet the requirements specified in the above designated sections of the MDOT 2012 Standard Specifications for Construction, and be furnished and operated as directed by the Engineer.

The Contractor shall maintain traffic such that no vehicle shall be required to drive into active work areas. Patch areas which extend more than halfway across the roadway shall be removed and replaced so as to provide a minimum of half the pavement width at all times for maintaining traffic.

The Contractor shall maintain pedestrian traffic at all times. For maintaining normal pedestrian traffic while performing sidewalk and driveway repair, Sidewalk Barricades shall be placed by the Contractor, as directed by the Engineer. "Sidewalk Closed" and/or "Cross Here" signs shall be placed, by the Contractor, when directed by the Engineer.

All temporary traffic/pedestrian control devices furnished by the Contractor shall remain the property of the Contractor. The City shall not be responsible for stolen or damaged signs, barricades, barricade lights or other traffic maintenance items. The Contractor shall replace damaged or missing traffic control devices immediately, at no additional cost to the City.

All existing signs, and signs erected by the City of Ann Arbor on this project shall be preserved, protected, and maintained by the Contractor. Existing City owned signs which are damaged by the Contractor during the work will be repaired by the City at the Contractor's expense.

Parking violation citations issued to the Contractor, subcontractor, and material suppliers including each of their respective employees shall be enforced under appropriate City Code.

Pedestrian barricades shall extend the full width of the sidewalk; be orange or white in color, with orange and white reflective sheeting; and be fully ADA compliant.

Type III Barricades shall have standard orange-and-white stripes on both sides of the barricade.

Sufficient signs shall be provided by the Contractor to insure the safety of the workers and the general public in accordance with the 2011 Edition of the MMUTCD.

"Construction Ahead" warning signs shall be placed, as indicated on the Plans, or as directed by the Engineer, prior to the start of work, regardless of the nature, magnitude or duration of the work.

**DETAILED SPECIFICATION
FOR
ITEM #207 –TYPE III LIGHTED BARRICADE, FURN & OPER
ITEM #208 – 42 INCH LIGHTED CHANNELIZING DEVICE, FURN & OPER
ITEM #209 – PLASTIC DRUM, LIGHTED, FURN & OPER
ITEM #210 – TEMPORARY TYPE B SIGNS, FURN & OPER
ITEM #211 – PORTABLE CHANGEABLE MESSAGE SIGN, FURN & OPER
ITEM #212 – SIDEWALK BARRICADE, FURN & OPER**

2 of 2

MEASUREMENT AND PAYMENT

All temporary traffic control devices furnished by the Contractor shall remain the property of the Contractor. The City shall not be responsible for stolen or damaged signs, barricades, barricade lights or other traffic maintenance items. The Contractor shall replace missing traffic control devices immediately, at no additional cost to the City.

Costs for transporting barricades and other temporary traffic control devices shall be included in the bid prices for the individual items of work.

For Type III Barricades, Channelizing Devices, Plastic Drums, Portable Changeable Message Signs, and Sidewalk Barricades payment shall be for the maximum quantity used at each project location at any one time.

For Temporary Type B Signs, payment shall be for the quantity used at each project location.

The completed work as measured for these items of work will be paid for at the Contract Unit Price for the following Contract (Pay) Items:

<u>PAY ITEM</u>	<u>PAY UNIT</u>
Type III Lighted Barricade, Furn & Oper	Each
42 inch Lighted Channelizing Device, Furn & Oper	Each
Plastic Drum, Lighted, Furn & Oper	Each
Temporary Type B Signs, Furn & Oper	Sq Ft
Portable Changeable Message Signs, Furn & Oper	Each
Sidewalk Barricade, Furn & Oper	Each

**DETAILED SPECIFICATION
FOR
ITEM #213 – CLEAN-UP & RESTORATION, SPECIAL**

1 of 2

DESCRIPTION

This item of work shall conform to Division IX, Section II, Item No. 891, Clean-Up & Restoration of the Public Services Area Standard Specifications, and Section 816 of Michigan Department of Transportation (MDOT) 2012 Standard Specifications for Construction, except as specified herein.

This work shall include the removal of all surplus materials from the site including; but not limited to: tools, dirt, rubbish, construction debris, and excess excavated material; the restoration of all hardscaped, landscaped and lawn areas; replacement of furniture, fixtures, fences, and similar features disturbed by the work; Basketball court coating; sweeping/cleaning road surfaces, culverts, drives, and sidewalks disturbed by the work. This work includes placing topsoil, fertilizer, seeding, and furnishing and installing mulch blankets on all disturbed areas as approved by the Engineer. Mulch blankets are required on all seeded areas.

MATERIALS

The materials shall meet the requirements specified in Sections 816.02 and 917 the Michigan Department of Transportation (MDOT) 2012 Standard Specifications as designated, as specified herein, and as approved by the Engineer:

- Topsoil – 4-inches in depth. See Section 917.07.
- Seed mixture shall be THM. See Table 8 16-1 for description and rate of application, and Table 917-1 for purity, germination, and proportions.
- Fertilizers shall be a Class A. See Section 816.03.B for rate of application, and Section 917.10.B.1 for composition requirements.
- Water used shall be obtained from fresh water sources and shall be free from injurious chemicals and other toxic substances.
- Mulch blankets shall be High Velocity Straw Mulch Blankets as specified in Section 917.15.B.1b.

CONSTRUCTION, MAINTENANCE, AND ACCEPTANCE

Perform restoration and establish turf in accordance Section 816.03 of MDOT 2012 Standard Specifications for Construction.

It is the responsibility of the Contractor to establish a dense lawn of permanent grasses, free from mounds and depressions prior to final acceptance and payment of this project. Any portion of a seeded area that fails to show a uniform germination shall be reseeded. Such reseeded shall be at the Contractor's expense and shall continue until a dense lawn is established. The Contractor is responsible for restoring all areas disturbed by his construction.

The Contractor shall maintain all lawn areas until they have been accepted by the Engineer. Lawn maintenance shall begin immediately after the grass seed is in place and continue until final acceptance with the following requirements:

**DETAILED SPECIFICATION
FOR
ITEM #213 – CLEAN-UP & RESTORATION, SPECIAL**

2 of 2

Lawns shall be protected and maintained by watering, mowing, and reseeding as necessary, until the period of time when the final acceptance and payment is made by the Engineer for the project, to establish a uniform, weed-free, stand of the specified grasses. Maintenance includes furnishing and installing additional topsoil, and reseeding all as may be required to correct all settlement and erosion until the date of final acceptance.

Damage to seeded areas resulting from erosion shall be repaired by the Contractor at the Contractor's expense. Scattered bare spots in seeded areas will not be allowed over three (3) percent of the area nor greater than 6"x 6" in size.

When the above requirements have been fulfilled, the Engineer will accept the lawn. Cleanup and Restoration must be performed upon the completion of each sub-phase of work (as described in the Detailed Specification for Project Schedule), and not as one single operation at the completion of the entire project.

MEASUREMENT AND PAYMENT

Measurement and payment for this item of work shall conform to Division IX, Section 2, Item No. 891, Clean-Up & Restoration of the Public Services Area Standard Specifications except as modified herein.

The completed work for "Clean-Up & Restoration, Special" will be paid for on a lump sum (LS) basis. 80% of said lump sum shall be paid upon completion and approval of the site by the Engineer. By May 31st of the year following the completion of the project, the Engineer will inspect the seeded turf to ensure that the end product is well established; weed free, and in a growing and vibrant condition. If the Engineer determines that the restored areas meet the project requirements, the remaining 20% of the lump sum will be paid. If the Engineer determines that the restored areas do not meet the project requirements, the Contractor will continue with any and all measures necessary to meet the project requirements. All costs associated with the remedial measures shall be borne entirely by the Contractor.

Pay Item

Clean-Up & Restoration, Special

Pay Unit

Lump Sum

**DETAILED SPECIFICATION
FOR
ITEM #214 – BASKETBALL POLE ASSEMBLY**

1 of 1

DESCRIPTION

The Basketball pole assembly includes the foundation, pole, backboard, rim, net and all hardware. The Contractor shall remove and dispose of the westerly basketball pole assembly within the area of sewer construction influence. The contractor shall procure a new assembly consisting of the same style, quality and material of pole, backboard, rim, net, and hardware. The pole shall be placed with a new concrete foundation to a height and alignment matching the easterly basketball pole assembly.

MEASUREMENT AND PAYMENT

All costs for removal and disposal of the existing assembly, new materials and assembly thereof, excavation, foundation, placement, and correct alignment shall be included in the bid price.

The completed work as measured for these items of work will be paid for at the Contract Unit Price:

Pay Item

Pay Unit

Basketball Pole Assembly

Each

**DETAILED SPECIFICATION
FOR
ITEM #220 – ADJUST STRUCTURE COVER, MODIFIED**

1 of 2

DESCRIPTION

This work shall consist of the final adjustment of existing public utility structure covers, including monument boxes, in accordance with Section 403 of Michigan Department of Transportation (MDOT) 2012 Standard Specifications for Construction, as herein specified, and as directed by the Engineer.

MATERIALS

The concrete used for encasing the final adjustment of all structure covers shall meet the requirements for P-NC concrete (658 lb/cyd) as specified in Section 601 of the MDOT 2012 Standard Specifications for Construction.

CONSTRUCTION METHODS

Manhole covers, water valve boxes and all other public utility underground access or control point covers shall be adjusted to conform to the finished surface section and elevation. The adjusting of castings in areas of concrete pavement or lawn shall be performed in a one-step process. The adjusting of castings in a HMA pavement area shall be done in two steps: step one is the lowering of the structure cover to below the subgrade elevation and plating of the structure; step two is the final adjustment to finish grade made prior to placing the HMA top surface.

All structures final adjustment are to be to the elevation, which results in their top surface being flush with the finished grade. The work is to be accomplished and checked by using a 10-foot straight edge parallel with the pavement centerline. Failure to meet these conditions will result in the readjustment of the structure and finish patching of the area, as directed by the Engineer, at the Contractor's expense.

All private utility manhole and valve covers (Edison, Gas, Ameritech, etc.) will be adjusted during this project by the Utility. It is the responsibility of the Contractor to coordinate with these private utilities by giving adequate notice and arranging for any adjustment of structures or valves by these utilities.

The transporting of replacement castings from and/or salvaged castings to the City of Ann Arbor Utilities Yard, at the W.R. Wheeler Service Center at 4251 Stone School Road, Ann Arbor, MI 48108, shall be considered included in the items of work "Drainage Structure Covers, Adjust, Modified". All salvaged covers and castings (of any type) shall be returned by the Contractor, at his expense, to the City's Yard at 2000 South Industrial Highway within two days from the date of their removal.

All drainage structures covers, utility covers, monuments, and gate valve boxes shall be backfilled with Grade HE concrete from the depth of excavation necessary for adjustment to an elevation 2" below the top flange or adjusted casting. This material shall be included in this item of work and will not be paid for separately.

The Contractor shall replace covers and/or castings, as directed by the Engineer.

There is a possibility that the Contractor may find hidden utility structures during the work. It is the Contractor's responsibility to inform the respective utility owner(s) of the findings. In such instances, the City may direct the Contractor to adjust the structure(s) to grade. This work will be paid as Adjust Structure Cover, Modified.

**DETAILED SPECIFICATION
FOR
ITEM #220 – ADJUST STRUCTURE COVER, MODIFIED**

2 of 2

MEASUREMENT AND PAYMENT

The completed work as measured for Adjust Structure Cover, Modified will be paid for at the contract unit price for the following contract item:

PAY ITEM

PAY UNIT

Adjust Structure Cover, Modified

Each

Adjust Structure Cover, Modified will be measured and paid for at the contract unit price for each structure that is adjusted, which price shall be payment in full for all labor, equipment and material needed to accomplish this work.

**DETAILED SPECIFICATION
FOR
ITEM #230 –MANHOLE TAP, 8 INCH**

1 of 1

DESCRIPTION

This work shall include making a connection or tapping into an existing manhole as required by the Plans. All work shall be done in accordance with the City of Ann Arbor Public Services Department Standard Specifications, and as directed by the Engineer.

CONSTRUCTION METHODS

The Construction Methods shall meet all requirements of the City of Ann Arbor Standard Specifications.

Make connections to existing manholes in accordance with the plans. If tapping an existing manhole, cut an opening into the receiving structure at least equal to the outside diameter of the inlet pipe plus 6 inches and insert the pipe with an approved boot. . Pack a layer of mortar at least 3 inches thick around the inlet pipe and strike smooth with the inner wall of the receiving structure.

The Contractor shall take care not to cause undue damage to the existing manhole while coring the new opening. Repair or replacement of existing manhole(s) damaged by Contractor operations during tapping shall be at the Contractor's expense and shall not be at any additional cost to the City.

MEASUREMENT AND PAYMENT

Completed work as measured for these items of work will be paid for at Contract Unit Price for the following Contract (Pay) Item:

PAY ITEM

Manhole Tap, 8 inch

PAY UNIT

Each

**DETAILED SPECIFICATION
FOR
ITEM #231 – EXISTING SEWER LEAD, VIDEO**

1 of 1

DESCRIPTION

This work shall include digital visual record of existing sanitary sewer leads in the Lafayette Road and Horman Court project areas. It is Contractor's responsibility to schedule this work with homeowner to gain access to the lead. This item will also include cleaning of the lead and removal and replacement of access cap if needed. This work will be performed on sewer service leads that fall inside construction limits as directed by Engineer.

The visual filming shall be:

5. Of professional quality, providing a clear, accurate and visual record of the entire length of existing sanitary sewer leads.
1. Carried-out under the supervision of the Engineer.
2. Completed and submitted at least 1 week prior to commencing work in the respective project areas.

The Contractor shall furnish one (1) copy of the completed visual record to the Engineer on DVD. An index of the footage shall be included with visual record indicating lead location by address and any defects located by distances. The Contractor shall retain a second copy of the video for its records.

Any portion of the film determined by the Engineer to be unacceptable for the documentation of existing conditions shall be filmed again at the Contractor's sole expense.

MEASUREMENT AND PAYMENT

The completed work as measured for these items of work will be paid for at the Contract Unit Prices for each sewer lead videoed over its entire length:

PAY ITEM

PAY UNIT

Existing Sewer Lead, Video

Each

Visual Tape Coverage shall include all labor, equipment, and materials required to perform the filming and to provide the finished video DVD to the Engineer.

**DETAILED SPECIFICATION
FOR
ITEM #232 – EXISTING SEWER LEAD, CONNECT**

1 of 1

DESCRIPTION

This work shall include locating, excavating, connecting existing sewer service leads to new service leads; and bulkheading and abandoning old lead to the sewer. The contractor shall locate an appropriate point of connection within the right of way for each sewer lead that minimizes disturbance to existing landscaping, pavement, and similar existing features, and protects the structural integrity of the existing leads.

CONSTRUCTION METHODS

The Construction Methods shall meet all requirements of the City of Ann Arbor Standard Specifications.

The contractor shall verify the existing lead diameter and material and install Fernco connection to the new sewer lead. The Contractor shall take care not to damage to the existing lead while making the connection. Repair or replacement of existing sewer lead by Contractor operations shall be at the Contractor's expense and shall not be at any additional cost to the City.

MEASUREMENT AND PAYMENT

The completed work as measured for these items of work will be paid for at the Contract Unit Prices for the connection to existing sewer leads:

PAY ITEM

PAY UNIT

Existing Sewer Lead, Connect

Each

The work shall include all labor, equipment, and materials required for the excavation, connection, bulkhead/abandon and backfill of the sewer leads.

**DETAILED SPECIFICATION
FOR
ITEM #240 – WATER MAIN PIPE ABANDONMENT
ITEM #241 – FIRE HYDRANT ASSEMBLY ABANDONMENT**

DESCRIPTION

This work shall include abandoning existing water mains, valves, valve wells, valve boxes, and fire hydrant assemblies of various sizes as required by the Plans. All work shall be done in accordance with the City of Ann Arbor Public Services Department Standard Specifications, and as directed by the Engineer.

MATERIALS

All materials shall meet the requirements specified in Division 7 and 9 of the MDOT 2012 Standard Specifications for Construction as follows:

Mortar Type II Section 702

MDOT Class II Sand Section 902

Masonry Units Section 913

Push-on joint plugs, caps, air relief assemblies (for grouting purposes), and thrust blocks shall conform to the City of Ann Arbor Standard Specifications.

METHODS OF CONSTRUCTION

The Construction Methods shall meet all requirements of the City of Ann Arbor Public Services Department Standard Specifications.

In locations as shown on the Plans or where abandoned water main, valves or valve wells are within 2.5 feet of the proposed subgrade, the pipe, valves or valve wells shall be removed completely. The resulting hole or trench shall be backfilled with Class II Sand, in maximum lifts of 12 inches, and be compacted to 95% of its maximum unit weight, if located within the influence paved surfaces or structures. Otherwise, backfill shall be Engineer approved native material, compacted to 90% of its maximum unit weight, in lifts of 12 inches or less, unless otherwise noted on the plans. Caps or plugs shall be installed in accordance with plans or as specified by Engineer.

For all water mains to be abandoned that are greater than 10 inches in diameter, the Contractor shall drain water from abandoned pipe to an adjacent storm sewer, fill the abandoned pipe with 400 psi (minimum) concrete grout, and backfill and compaction of the trench at all access points.

Abandoned (salvaged) valve operating nuts, fire hydrant assemblies and structure covers shall be delivered to the City of Ann Arbor Public Works Unit located at the W.R. Wheeler Service Center at 4251 Stone School Road, Ann Arbor, MI 48108 within two days of their removal. Valve boxes should be disposed of at the contractor's sole expense.

MEASUREMENT AND PAYMENT

The unit price for the pay "Water Main Pipe Abandonment" shall be paid for on a linear foot (LF) basis and includes all labor, material and equipment costs necessary to abandon or remove the pipe including, but not limited to, excavation, cutting of pipe, push-on joint plugs, caps and thrust blocks, brick and mortar bulkheads, grouting, the furnishing, placement, and compaction of approved granular backfill material, as required, and the removal and proper disposal off-site of excess materials. In addition, this pay item includes the removal and salvage of valves, valve boxes, and manhole rings and covers, the removal of the top 4 feet of valve wells, and breaking out the valve well base.

The unit price for the pay item "Fire Hydrant Assembly Abandonment," includes all labor, material and equipment costs associated with the complete removal of the existing fire hydrant assembly, as specified herein, including but not limited to, excavation MDOT CL II Backfill and compaction; pipe cutting; thrust block removal; pipe plug; thrust block; salvaging of fire hydrant, valve and valve box and delivery of fire hydrant, valve and valve box to the City of Ann Arbor Public Works Unit located at the W.R. Wheeler Service Center at 4251 Stone School Road, Ann Arbor, MI 48108.

PAY ITEM

Water Main Pipe Abandonment, Modified

Fire Hydrant Assembly Abandonment

PAY UNIT

LF

Each

**DETAILED SPECIFICATION
FOR
ITEM #242 – 6 INCH TEMPORARY WATER MAIN LINE STOP
ITEM #243 – 8 INCH TEMPORARY WATER MAIN LINE STOP**

DESCRIPTION

All water main work shall be performed in accordance with the current City of Ann Arbor Public Services Area Standard Specifications and as detailed herein.

The Contractor shall furnish all materials, labor and equipment to properly install and set water main line stops into the existing water main(s) at the locations as shown on the plans or as directed by the Engineer.

If the existing mains, upstream and downstream of the proposed new water mains cannot be shut down or taken out of service, locations of proposed line stops will be identified by the Engineer. To ensure that the entire operation shall be accomplished without interruption of service or flow, the installation shall be accomplished by Contractor personnel skilled and experienced in the procedures specific to line stops of the required size(s).

The work shall include, but not be limited to; pavement saw-cutting; excavation and disposal of excavated material; the furnishing, installation, and removal of sheeting and/or shoring where needed; the furnishing, placement and compaction of approved bedding and backfill materials; furnishing and placing suitable, clean, gravel to create a stable working surface at the bottom of the excavation; de-watering; pipe cleaning, measuring, and performing all advance work necessary to prepare for the performance of the line stop; nighttime lighting as required; the removal of all materials and equipment associated with the work when no longer needed; and, any other items needed to complete the work as detailed on the plans and as specified herein.

MATERIALS

Bedding and backfill for areas contained within a segment of water main designated as Trench Detail I (under roadbed), Modified, shall be Granular Material, Class II, meeting the requirements of Section 902. For work within a segment of water main designated as Trench Detail V (outside of the 1:1 influence line of roadbed or curb and gutter), Modified, Granular Material, Class II and Engineer approved native material, placed in accordance with the trench details, shall be used.

The Contractor shall submit to the Engineer two (2) sets of drawings, furnished by manufacturers, fully and distinctly illustrated and describing the Line Stop fittings proposed to be furnished. Work shall not commence until such time as the drawings have been reviewed and accepted by the Engineer.

Line Stop Fittings shall be full encirclement, pressure retention type split tee. It shall consist of two steel weldments; an upper line stop flange saddle plate and a lower saddle plate. These two saddle plates shall be contiguous.

Line Stop Flange: The outlet of each fitting shall be machined from a 150 lb. forged steel flange (ASTM A181 or A105) or from pressure vessel quality steel plate (ASTM A285, Grade C); flat faced and drilled per ANSI B16.5). Suitable independently operated locking devices shall be provided in the periphery of the flange to secure the completion plug.

Line stop Nozzle: The nozzle, which lies between the saddle and the flange shall be fabricated from steel pipe (ASTM A234). After welding and stress relief, the nozzle shall be accurately bored as follows to accommodate the Line stop plugging head:

- a) Machine an internal circular shoulder to seal against the circumferential gasket carried on the plugging head.

Completion Plug: The completion plug shall be machined from a stress relieved carbon steel weldment. It shall contain two (2) circumferential grooves: one to receive the locking devices from the Line stop flange, and the second to contain a compressible "O" ring to seal pressure tight against the bore of the flange.

Blind Flange: Each Line stop fitting shall be closed with a blind flange. Facing and drilling of the blind flange shall be compatible with that of the Line stop flange. Minimum blind flange thickness shall be that of AWWA Spec. 207, Class D.

Saddle Alignment Marking: Each saddle-half shall be matched and marked with serial numbers, to insure proper alignment in the field.

Fasteners: All bolts, studs, and nuts used on Line stop, drain/equalization fittings, blind flange, and other elements that shall remain upon completion of the work shall be stainless steel and meet the requirements of ASTM F 593.

General: Manufacturer will exercise extreme care to insure that weldments are of adequate strength, properly shaped, securely reinforced, and free from distortion that could stress the ductile iron main during installation, pressure tapping, or Line stopping operations. All steel shall meet the requirements of ASTM A36, as a minimum. All weldments shall be braced and stress relieved.

Gaskets: Shall be molded from elastomer compounds that resist compression setting and are compatible with water in the 32 to 140 deg. F temperature range.

Upper Line stop Flange Saddle: Shall consist of a saddle plate, a Line stop flange, and a Line Stop nozzle. The interior of the saddle plate, adjacent to and concentric with the O.D. of the nozzle, shall be grooved to retain a gasket which shall seal the saddle plate to the exterior of the ductile iron main. This gasket shall constitute the only seal between the main and the fitting. The flange saddle shall also meet the following requirements:

- a) Saddle plate shall be of a minimum of 0.375" in thickness. It shall be shaped to be concentric to the outside of the ductile iron main. The smallest I.D. of the saddle and its interior rings shall exceed the O.D. of the main by a minimum of 0.250" to allow for ovality of the main;
- b) Line stop nozzle of 0.375" min. wall thickness shall be securely welded to the saddle plate;
- c) The Line Stop flange shall be securely welded to the nozzle. After welding, the assembly shall be braced, stress relieved, and bored to receive the completion plug and the circumferential gasket of the Line Stop machine plugging head; and,
- d) Bolt, nut of stud, nut, and washer assemblies shall be furnished to draw the upper and lower saddles together for sealing. Bolting brackets shall be gusseted.

Lower Saddle Plate: Saddle plate shall be of a minimum 0.375" thickness and shall be shaped to be concentric to the outside brackets shall match upper half.

EQUIPMENT

The equipment shall consist of a cylindrical plugging head that contains a flat, expandable elastomer sealing element. The plugging head shall be advanced into and retracted from the main by means of a linear actuator. When retracted, the plugging head and carrier are housed in an adapter, bolted pressure tight between the tapping valve and the actuator.

Sealing Element: The element shall be monolithically molded from a suitable polyurethane compound. The element shall be flat in a plane perpendicular to the flow in the main. Minimum thickness of the element shall be 4". The bottom of the element shall be semi-circular to conform to the bore of the main.

Drilling equipment: Shall be in good working condition, equipped with power drive to insure smooth cutting, and to minimize shock and vibration. Cutting equipment shall be carbide tipped and capable of being replaced without removal from the jobsite.

Plugging Head: The diameter of the cylindrical plugging head shall be slightly smaller than the bore of the Line Stop nozzle. The plugging head shall have a suitable circumferential gasket to seal against the shoulder in the Line stop nozzle. This gasket shall also seal against the sealing element to prevent bypass flow around the Line stop.

Deposits in Bore of Main: The semi-cylindrical bottom of the plugging head shall be designed to break and dislodge tuberculation and other deposits in the bore of the main which might interfere with a satisfactory Line stop.

CONSTRUCTION METHODS

Installation of proposed line stops mains will require work in close proximity to existing utilities. This must be taken into consideration when the contractor determines the required trench safety requirements. All excavation shall conform to MIOSHA Standards; the Contractor is solely responsible for determining all excavation and trench safety requirements.

If necessary, The City will reduce the pressure to 100 psig or less for the duration of the installations. The entire operation of installing the line stop shall be accomplished without reduction of water pressure in the main(s) below 100 psig. It shall be the responsibility of the Contractor to verify pressure prior to commencing the installation.

Preliminary Field Inspection of Water Main:

Dimensional, specification, and other data regarding the existing mains have been taken from existing records. This information may be inaccurate, out of date, and/or inadequate. The data have not been verified by field inspections. Further, the water main consists of ductile iron pipe which may contain dimensional and structural flaws. In addition, the Contractor shall anticipate that exterior main conditions, bells, service connections, or presence of adjoining utilities may require relocation of proposed line stop. Prior to proceeding with the installation of any line stop, it is necessary to know the exact main outside diameter of the water main, if it has any ovality, and the internal diameter of the pipe before line stop fittings and plugging head sealing elements can be manufactured and/or ordered.

Prior to ordering material, Contractor shall excavate at each proposed location and carefully measure the outside diameter of the water main with calipers along at least four (4) locations to determine ovality and the critical outside diameter of the water main. The Contractor shall determine main wall thickness, uniformity, and structural integrity by means of ultrasonic testing. Data shall be taken to determine extent of internal deposits, tuberculation, etc..

If the Engineer determines that Contractor's data are not adequate, the Engineer may direct Contractor to make one or more pressure taps on main to obtain test pipe coupons for the Engineer's evaluation. The minimum size of the test coupon shall be 5" diameter, drilled through a nominal 6" valve. Pressure tapping saddles and other materials used for inspection taps shall conform to the requirements of this Detailed Specification. The Contractor shall anticipate that heavy interior corrosion and/or tuberculation exists within the water main.

If, in Engineer's opinion, the proposed location is unsatisfactory based on measurements of the existing pipe at the locations of the proposed line stops, the Engineer will direct excavation at another site. Excavating, de-watering, inspections, backfill, and restoration will be paid for

separately in accordance with the applicable contract unit prices or Section 109.05.C and 109.05.D whichever the Engineer deems most appropriate.

Because of possible internal corrosion and deposits in existing water mains, a "bottle-tight" shut down may not occur. A satisfactory shutdown which allows the work to be accomplished (i.e. valve replacement, water main tie-in, etc.) using drainage pumps to de-water excavations, with workmen wearing boots and raingear, if necessary, must be obtained. The Contractor will not be allowed to proceed with further work until an acceptable shutdown is achieved. The Contractor shall be aware that this may require the halting of work and re-scheduling of all work operations.

Contractor shall power wire brush and grind the exterior of the water main to remove any debris, corrosion deposits, or other surface irregularities that might interfere with proper seating and sealing of each line stop fitting against each main. Any structural defects in the water main, service connections, appurtenances, adjacent utilities, etc., that could interfere with the line stop installation shall be immediately reported to Engineer.

All line stop fittings and appurtenances shall be cleaned and disinfected in accordance with the current City of Ann Arbor Public Services Area Standard Specifications prior to bolting any of the line stop fittings in place or commencing any pipe cutting.

Contractor shall fit upper and lower saddle plate assemblies to main, thoroughly checking for proper fit to main. Under no circumstances shall Contractor attempt to force, reshape, or bend saddle plates by excessive tightening of saddle studs while the line stop fitting is assembled around the main. Any required retrofitting shall be accomplished with the fitting removed from the main. Any damage to fitting, accessories, or main shall be repaired at Contractor's expense to the satisfaction of Engineer.

Upper and Lower saddle halves shall be drawn together by bolt assemblies and the Saddle plates shall be bolted together in the horizontal position.

All line stop work shall be performed in accordance with the equipment manufacturers approved work procedures and installation guidelines.

Final closure of the water main shall be accomplished by insertion of a manufacturer-approved completion plug. The Contractor shall test the completion plug sealing through the use of a bleed off assembly in the machine housing.

The Contractor shall remove the temporary valve and the installation of a blind flange shall be completed.

The Contractor shall place polyethylene encasement meeting the requirements of the City of Ann Arbor Standard Specifications for Construction around the upper and lower saddle halves, the blind flange, and to a point at least 1 foot on either side of the saddle halves. All polyethylene encasement shall be securely taped to the water main such that water entry is minimized to the greatest extent possible.

MEASUREMENT AND PAYMENT

The unit prices for this item of work shall include all labor, material, and equipment costs to perform all the work specified in the Standard Specifications and as modified by this Detailed Specification.

PAY ITEM

6 inch Temporary Water Main Line Stop

8 inch Temporary Water Main Line Stop

PAY UNIT

Each

Each

**DETAILED SPECIFICATION
FOR
ITEM #261 – PAVEMENT REMOVAL, ANY THICKNESS**

1 of 2

DESCRIPTION

This work includes removal of pavement accordance with Section 204 of the Michigan Department of Transportation (MDOT) 2012 Standard Specifications, except as modified herein, and as directed by the Engineer.

CONSTRUCTION METHOD

The Contractor shall sawcut and remove pavement as shown on the Plans, as marked in the field, and as directed by the Engineer. The Engineer will measure the removal of HMA surface, any thickness, overlying a material designated for removal or that is required to remain in place, as Pavt, Rem. The Engineer will measure the removal of the underlying material separately.

If concrete or masonry pavements are encountered beneath the HMA surface being removed, the Engineer will measure each type of additionally encountered pavement at the unit price for Pavt, Rem.

Bricks/masonry units, if present, shall removed, salvaged, and neatly stacked/stockpiled by the Contractor, and later delivered by the Contractor to a City owned facility as directed by the Engineer.

The Contractor shall remove and properly dispose of all excavated material and debris, including all asphalt and concrete. The Contractor shall not stockpile excavated materials overnight on, or adjacent to, the site.

In areas where pavement removal is to be performed adjacent to existing pavement that is to remain in place, the pavement shall be sawcut prior to removal. Backhoe teeth, jackhammers equipped with spike points, milling machines, and backhoe mounted wheel cutters shall not be used.

Damage to adjacent pavement, pavement base, subbase, curb, curb and gutter, sidewalk, utility structures, or other site features, due to removal operations shall be repaired by the Contractor, at the Contractor's expense, as directed by the Engineer.

The Contractor shall remove pavements full depth unless other shown on the plans or directed by the Engineer.

The Contractor shall construct butt-joints, and trim butt-joints just prior to HMA paving as shown on the Plans, and as directed by the Engineer.

At various times throughout the work, the Engineer may direct the Contractor to use smaller and/or lighter equipment, and to defer certain work tasks, in order to protect the grade and/or adjacent areas. The Contractor shall not be entitled to any additional compensation for the use of smaller equipment, lighter equipment, or work task deferral.

MEASUREMENT AND PAYMENT

The areas to be removed shall be marked and measured prior to removal of any material. Measurement shall take place with both the Engineer and the Contractor (or their agents) present. Both parties shall come to an agreement regarding removal quantities prior to the actual removal of pavement.

**DETAILED SPECIFICATION
FOR
ITEM #261 – PAVEMENT REMOVAL, ANY THICKNESS**

2 of 2

The completed work as measured for these items of work will be paid at the Contract Unit Prices for the following Contract (Pay) Item:

PAY ITEM

PAY UNIT

Pavement Removal. Any Thickness

Square Yard

The unit prices for these items of work shall include all labor, material, and equipment costs to perform all the work specified in the Standard Specifications and as modified by this Detailed Specification.

**DETAILED SPECIFICATION
FOR
ITEM #262 - REMOVE CONCRETE CURB OR CURB & GUTTER –
ANY TYPE, MODIFIED
ITEM #263 - REMOVE CONCRETE SIDEWALK, RAMP AND DRIVES –
ANY THICKNESS, MODIFIED**

1 of 3

DESCRIPTION

This work shall consist of removing concrete curb, gutter, curb and gutter, integral curb, concrete pavement, sidewalk, sidewalk ramps, drive openings, and drive approach pavements as shown on the plans, as detailed in the Specifications, and as directed by the Engineer, in accordance with Section 204 of the Michigan Department of Transportation (MDOT) 2012 Standard Specifications for Construction, except as specified herein, and as directed by the Engineer.

CONSTRUCTION METHODS

Curb, gutter, curb and gutter, sidewalk, sidewalk ramps, drive openings, and drives shall be replaced within 24 hours of their removal.

The Contractor shall remove concrete curb, gutter, curb & gutter, integral curb, pavement, sidewalk, sidewalk ramps, drive openings, and drives, all regardless of the type and thickness, and all as shown on the Plans, as detailed in the Specifications, and as directed by the Engineer.

Prior to the start of work, the Engineer and Contractor together shall identify and field measure all items to be removed. The Engineer shall approve of all removal limits prior to any removals being performed by the Contractor.

The Contractor shall perform full-depth saw cutting at removal limits, including those necessary to construct 2-foot wide MDOT Type M drive openings, and including those necessary to provide for the partial removal of existing drive approaches as shown on the Plans, as directed by the Engineer, and as marked for removal. The Contractor shall cut steel reinforcement bars as directed by the Engineer at all areas of removal. All saw cutting shall be performed under wet conditions to prevent excessive airborne dust. All resulting slurry and debris shall be cleaned up to the satisfaction of the Engineer.

The Contractor shall excavate, cut, remove stumps, remove brush, grade, and trim as needed and as directed, and shall import, furnish, fill, place, grade, and compact granular material as needed to: construct new concrete items; to repair or replace existing concrete items; to relocate existing concrete items to their new specified/directed elevations/locations, including all necessary grading at elevation changes of curb and gutter, sidewalks and ramps; and at locations where existing concrete items are to be removed and turf is to be established in its place.

The Contractor shall coordinate with the City Forester prior to the removal of any tree roots.

At various times throughout the work, the Engineer may direct the Contractor to use smaller and/or lighter equipment, and to defer certain work tasks, in order to protect the grade and/or adjacent areas. The Contractor shall not be entitled to any additional compensation for the use of smaller equipment, lighter equipment, or work task deferral.

The Contractor shall shape, grade, and compact the existing roadbed materials to the cross-section(s) as indicated on the Plans, as detailed in the Specifications, and as directed by the Engineer.

**DETAILED SPECIFICATION
FOR
ITEM #262 - REMOVE CONCRETE CURB OR CURB & GUTTER –
ANY TYPE, MODIFIED
ITEM #263 - REMOVE CONCRETE SIDEWALK, RAMP AND DRIVES –
ANY THICKNESS, MODIFIED**

2 of 3

The Contractor shall use blade graders, maintainers, vibratory rollers, and/or other equipment as necessary, and as directed by the Engineer. The use of each specific piece of equipment is subject to the approval of the Engineer.

The Engineer may direct aggregate base materials to be either removed from or added to the job-site, to properly complete the work. Where the Engineer directs the addition of such materials, they shall be paid for as either the Item of Work: “Aggregate Base, ___ inch, Modified”. Where the Engineer directs such materials to be removed, they will not be paid for separately, but shall be included in the appropriate concrete removal item.

Concrete removal outside the edge-of-metal shall be paid for as the appropriate item of either “Remove Concrete Curb or Curb & Gutter - Any Type, Modified”, or “Remove Concrete Sidewalk, Ramp and Drives - Any Thickness, Modified”.

Where existing concrete curb or curb & gutter is to be replaced on a street with a concrete (or brick) base, the Engineer may direct the Contractor to remove a 1-to-2-foot wide, full-depth section of pavement and pavement base from immediately in front of the curb & gutter. As part of this pavement/base removal, the Contractor shall perform additional (double) full-depth saw-cutting along the entire removal limits, and shall take sufficient care so as not to damage and/or disturb any adjacent pavement, pavement base, and/or any other site feature, all as directed by the Engineer. The removals shall be to a sufficient width and depth to allow for the placement and removal of the curb & gutter formwork. After the removal of the formwork, the Contractor shall replace the concrete base to its original thickness and elevation(s).

Excavated/removal areas shall be adequately protected with barricades and/or fencing at all times.

Removed or excavated materials which are not incorporated into the work shall become the property of the Contractor and shall be immediately removed and properly disposed of off-site. Removed or excavated materials may not be stockpiled overnight on, or adjacent to, the site.

Subbase or subgrade materials removed without authorization by the Engineer shall be replaced and compacted by the Contractor at the Contractor's expense, with materials specified by the Engineer.

Sidewalk ramp removal shall be measured and paid for as “Remove Concrete Sidewalk, Ramp and Drives - Any Thickness, Modified”.

Integral curb and gutter that is removed as part of “Remove Concrete Pavement (Repair)” shall be measured and paid for by the square yard, along with the pavement removal quantity.

All sawcutting required for removals shall be included in the appropriate item of work, and will not be paid for separately. Payment for saw cutting to create or modify Type M openings and to allow for the partial removal of existing drives shall be included in the price of the item of work, “Remove Concrete Sidewalk, Ramp and Drives - Any Thickness, Modified”, and will not be paid for separately.

**DETAILED SPECIFICATION
FOR
ITEM #262 - REMOVE CONCRETE CURB OR CURB & GUTTER –
ANY TYPE, MODIFIED
ITEM #263 - REMOVE CONCRETE SIDEWALK, RAMP AND DRIVES –
ANY THICKNESS, MODIFIED**

3 of 3

MEASUREMENT AND PAYMENT

Concrete removal items shall be field measured and paid for at the Contract Unit Prices for their respective Contract (Pay) Items as follows:

<u>PAY ITEM</u>	<u>PAY UNIT</u>
Remove Concrete Curb or Curb & Gutter - Any Type, Modified	Linear Foot
Remove Concrete Sidewalk, Ramp and Drives - Any Thickness , Modified	Square Foot

The unit prices for these items of work shall include all labor, material, and equipment costs to perform all the work specified in the Standard Specifications and as modified by this Detailed Specification.

**DETAILED SPECIFICATION
FOR
ITEM #264 – MAINTENANCE GRAVEL**

1 of 1

DESCRIPTION

This work consists placing maintenance gravel in accordance with Section 306 of the Michigan Department of Transportation (MDOT) 2012 Standard Specifications for Construction, and as directed by the Engineer.

MATERIALS

Maintenance Gravel material will be Dense-Graded Aggregate 21AA in accordance with that specified in Sections 306.02 and 902 of the MDOT 2012 Standard Specifications for Construction.

CONSTRUCTION METHODS

Maintenance Gravel will be constructed in accordance with Section 306.03 of the MDOT 2012 Standard Specifications for Construction, and as directed by the Engineer.

MEASUREMENT AND PAYMENT

The completed work will be paid for at the contract unit price for the following contract item (pay item).

PAY ITEM

PAY UNIT

Maintenance Gravel

Ton

Maintenance Gravel will be measured by the unit ton in accordance with Section 306.04 of the MDOT 2012 Standard Specifications for Construction, and as directed by the Engineer, and will be paid for at the unit price per ton. The unit price for this contract item includes all labor, material, and equipment costs required to perform the work.

**DETAILED SPECIFICATION
FOR
ITEM #265 - SUBGRADE UNDERCUTTING AND BACKFILL - TYPE I, MODIFIED**

DESCRIPTION

This work includes removal of unsuitable subgrade material(s) in the areas and limits identified by the Engineer, and backfill with Class II Granular Material in accordance with the City of Ann Arbor Standard Specifications for Construction and the Michigan Department of Transportation (MDOT) 2012 Standard Specifications for Construction, except as herein specified.

MATERIALS

Materials will be in accordance with those specified in Section 902 of the Michigan Department of Transportation (MDOT) 2012 Standard Specifications for Construction.

CONSTRUCTION METHOD

After the pavement has been removed, and/or after rough/finish grading, and/or at the time of proof rolling, the Engineer may inspect the grade to determine the need for, and the limits of, undercuts. After undercut areas are excavated to the depths as directed by the Engineer, the areas shall be trimmed, shaped, evenly graded and re-compacted to not less than 95% of the soils maximum unit weight as determined by the AASHTO T-180 test. The Contractor shall properly dispose of all excess materials.

The undercut area shall be backfilled with Granular Material, Cl II. The backfill material shall be compacted to not less than 98% of its maximum unit weight as determined by the AASHTO T-180 test.

The Contractor shall remove, add to, re-shape, re-grade, and re-compact the existing roadbed materials, and shall construct the roadway to the cross-section(s) as indicated on the Plans, as detailed in the Specifications, and as directed by the Engineer. The Contractor shall use blade graders, maintainers, vibratory rollers, and/or other equipment as necessary, and as directed by the Engineer, for this work. Use of each specific piece of equipment is subject to the approval of the Engineer.

At various times throughout the work, the Engineer may direct the Contractor to use smaller and/or lighter equipment, and to defer certain work tasks, in order to protect the grade and/or adjacent areas. The Contractor shall not be entitled to any additional compensation for the use of smaller equipment, lighter equipment, or work task deferral.

MEASUREMENT AND PAYMENT

These items of work shall be measured for payment by calculating the volume of the undercut excavation prior to the placement of backfill. The completed work as measured for these items of work will be paid for at the Contract Unit Price for the following Contract (Pay) Item:

PAY ITEM

PAY UNIT

Subgrade Undercutting and Backfill, Type I, Modified

Cubic Yard

The unit price for this item of work shall include all labor, material, and equipment costs to perform all the work specified by this Detailed Specification.

**DETAILED SPECIFICATION
FOR
ITEM #266 – AGGREGATE BASE, 8 INCH, MODIFIED**

DESCRIPTION

This work consists constructing an aggregate base course on a surface approved by the Engineer. Work will be performed in accordance with Section 302 of the Michigan Department of Transportation (MDOT) 2012 Standard Specifications for Construction, and as directed by the Engineer.

MATERIALS

Aggregate Base material will be Dense-Graded Aggregate 21AA in accordance with that specified in Sections 302.02 and 902 of the MDOT 2012 Standard Specifications for Construction.

CONSTRUCTION METHODS

Aggregate Base will be constructed in accordance with Section 302.03 of the MDOT 2012 Standard Specifications for Construction, and as directed by the Engineer.

MEASUREMENT AND PAYMENT

The completed work will be paid for at the contract unit price for the following contract item (pay item).

PAY ITEM

PAY UNIT

Aggregate Base , 8 inch, Modified

Ton

Aggregate Base will be measured by the unit ton in accordance with Section 302.04 of the MDOT 2012 Standard Specifications for Construction, and as directed by the Engineer, and will be paid for at the unit price per ton. The unit price for this contract item includes all labor, material, and equipment costs required to perform the work.

**DETAILED SPECIFICATION
FOR
ITEM #267 – MACHINE GRADING, MODIFIED**

DESCRIPTION

This work shall consist of constructing earth grades by excavating, cutting, filling, trimming, and grading; general restoration, and sign removals in accordance with the Detailed Specifications elsewhere herein; and maintaining the work in a finished condition until such time that it is accepted by the Engineer. This work shall be done as shown on the Plans, as detailed in the Specifications, and as directed by the Engineer, and in accordance with Section 205 of the 2012 edition of the MDOT Standard Specification for Construction, except as specified herein.

CONSTRUCTION METHOD

The Contractor shall construct earth grades as required to develop the typical and/or detailed cross-section(s) as shown on the Plans, as detailed in the Specifications, and as directed by the Engineer. This shall include, but not be limited to, the excavation of concrete and HMA pavement, soil, rocks of any size, stumps, trees less than 8 inches, logs, and bricks; the removal and proper disposal off-site of surplus excavated material; the scarifying, plowing, disking, moving and shaping of earth; the trimming, grading, compaction and proof-rolling of the prepared subgrade; the importing, furnishing, placement and compaction of embankment and/or fill materials; the full depth saw-cutting of pavement at the removal limits; the grading of sideslopes; general restoration in accordance with the Detailed Specifications elsewhere herein and the general items of the work as specified herein. Road subbase and base materials shall be paid for separately.

The Contractor shall remove, add to, re-shape, re-grade, and re-compact the existing roadbed materials, and shall construct the roadway to the cross-section(s) as indicated on the Plans, as detailed in the Specifications, and as directed by the Engineer. The Contractor shall use blade graders, maintainers, vibratory rollers, and/or other equipment as necessary, and as detailed in the Specifications and as directed by the Engineer, for this work. Use of each specific piece of equipment is subject to the approval of the Engineer.

The Contractor shall remove, salvage, deliver to any location within the City limits, and neatly stack/stockpile all bricks, if present, as directed by the Engineer.

The Contractor shall remove other surface features, including signs, located within the grading limits and not otherwise identified, as directed by the Engineer. Signs shall be salvaged and provided to City as directed by the Engineer.

The Contractor shall move excavated and/or imported materials longitudinally and/or transversely where necessary, and as directed by Engineer.

The Contractor shall keep the work well graded and drained at all times.

The Contractor shall not use rubber-tired equipment on the subgrade, when its use causes or may cause, in the opinion of the Engineer, damage to the subgrade. The Contractor shall conduct its operation(s), and provide all necessary equipment, to insure the satisfactory completion of the work without damaging the subgrade. This includes the transporting, stockpiling, rehandling, and movement of materials over additional distances, in lieu of driving on an unprotected, or partially unprotected, subgrade.

**DETAILED SPECIFICATION
FOR
ITEM #267 – MACHINE GRADING, MODIFIED**

2 of 2

The Contractor is solely responsible for the maintenance and protection of the subgrade. Further, any damage to the subgrade which, in the opinion of the Engineer, is caused as a result of the Contractor's operation(s), or its subcontractors' or suppliers' operation(s), shall be repaired by the Contractor at the Contractor's expense. This includes any additional earthwork and/or maintenance materials as directed by the Engineer, for the purposes of the Contractor's maintenance and protection of the subgrade. The Contractor shall not be entitled to any additional compensation for the implementation of these procedures.

The Contractor shall perform all rough and/or finish grading and compaction to the grades shown on the Plans, as detailed in the Specifications, and as directed by the Engineer.

The Contractor shall proofroll all graded and compacted surfaces in the presence of the Engineer as detailed in the Specifications. The Engineer will monitor the proofrolling operation to locate deleterious and/or uncompacted materials, and will direct undercuts as necessary.

At various times throughout the work, the Engineer may direct the Contractor to use smaller and/or lighter equipment, and to defer certain work tasks, in order to protect the grade and/or adjacent areas. The Contractor shall not be entitled to any additional compensation for the use of smaller equipment, lighter equipment, or work task deferral.

The Contractor shall take any and all steps necessary to avoid interruption in the mail delivery, and solid waste, recycling, and compostable pick-up within the project limits. This shall include the temporary relocation of mailboxes, where required by the Engineer, as well as moving of all solid waste/recycling/compost containers to the nearest cross street.

The Contractor shall coordinate with the City Forester prior to the removal of any tree roots 2 inches or larger in size.

Butt joints are included in the pay item "Machine Grading".

Topsoil, seeding and mulch shall be paid for as part of the item "Clean-Up & Restoration, Special".

MEASUREMENT AND PAYMENT

Measurement for payment for the item "Machine Grading" shall be the along the road centerline within the limits of the work. At intersections, measurements shall be along only one of the streets. Machine grading shall be paid only once, regardless of any additional re-working that may be required.

The completed work as measured for this item of work will be paid for at the Contract Unit Price for the following Contract (Pay) Item:

PAY ITEM

Machine Grading, Modified

PAY UNIT

Station

The unit price for this item of work shall include all labor, material, and equipment costs to perform all the work specified in the Standard Specifications and as modified by this Detailed Specification.

**DETAILED SPECIFICATION
FOR
ITEM #270 – HMA, 5E3 - PAVEMENT TOP AND LEVELING COURSES
ITEM #271 – HMA, 3C - PAVEMENT BASE COURSE
ITEM #272 – HMA, LVSP - PAVEMENT LEVELING COURSE
ITEM #273 – HMA, LVSP - PAVEMENT TOP COURSE
ITEM #274 – HMA, 36A - PAVEMENT TOP COURSE**

DESCRIPTION

Hot Mix Asphalt (HMA) pavement base, leveling, and top courses shall be constructed in accordance with Section 501 of the 2012 Michigan Department of Transportation (MDOT) Standard Specifications for Construction, except as modified herein, and as directed by the Engineer.

MATERIALS AND EQUIPMENT

The HMA mixtures to be used for this work shall be as follows:

<u>Item Description</u>	<u>HMA Mixture</u>	<u>MDOT Section</u>
HMA, 3C - Pavement Base Course	3C	501
HMA, 5E3 - Pavement Top and Leveling Course	5E3	501
HMA, LVSP - Pavement Leveling Course	LVSP	501
HMA, LVSP - Pavement Top Course	LVSP	501
HMA, 36A - Pavement Top Course	36A	501

Binders for 3C and 5E3 shall be PG 64-28; and for 36A and Superpave mix LVSP shall be PG 58-28 in accordance with the HMA Application Table shown on the Plans, and shall meet the requirements specified in Section 904 of the 2012 MDOT Standard Specifications for Construction, and any current supplemental MDOT specifications.

The Contractor shall have a 10-foot long straight-edge, backhoe, air-compressor and jackhammer available during all paving operations.

The Aggregate Wear Index (AWI) number for this project is 260. This AWI number applies to all aggregates used in all top course mixtures. Blending aggregates to achieve this AWI requirement is permitted in accordance with current MDOT Standards, and Supplemental Specifications.

Reclaimed Asphalt Pavement (RAP) in HMA Mixtures

The use of Reclaimed Asphalt Pavement (RAP) in HMA mixtures shall be in accordance with Section 501.02.A.2 of the 2012 MDOT Standard Specifications for Construction, and the City of Ann Arbor Standard Specifications.

All equipment shall conform to Section 501.03.A of the 2012 MDOT Standard Specifications for Construction, except as modified herein.

The Contractor shall have a 10 foot long straight edge, rubber-tired backhoe (Case 580 type, or equivalent), air-compressor with the ability to develop a minimum pressure of 100 pounds per square inch and continuous rated capacity of 150 cubic feet per minute of air flow, and jackhammer available during all paving operations. The Contractor shall be required to perform any miscellaneous cleaning, trimming, material removal, and other tasks as required by the Engineer in order to ensure the proper and orderly placement of all HMA materials on this project.

**DETAILED SPECIFICATION
FOR
ITEM #270 – HMA, 5E3 - PAVEMENT TOP AND LEVELING COURSES
ITEM #271 – HMA, 3C - PAVEMENT BASE COURSE
ITEM #272 – HMA, LVSP - PAVEMENT LEVELING COURSE
ITEM #273 – HMA, LVSP - PAVEMENT TOP COURSE
ITEM #274 – HMA, 36A - PAVEMENT TOP COURSE**

2 of 5

The Contractor shall provide sufficient rollers to achieve the specified asphalt densities.

At various times throughout the work, the Engineer may direct the Contractor to use smaller and/or lighter equipment, and to defer certain work tasks, in order to protect the grade and/or adjacent areas; including hauling units. The Contractor shall not be entitled to any additional compensation for the use of smaller equipment, lighter equipment, or work task deferral.

CONSTRUCTION METHODS

All concrete work shall be completed prior to placing HMA mixtures.

The Contractor shall place HMA wedges using the base, leveling, and top course mixtures specified herein, as directed by the Engineer, prior to placing the top course. Such wedging shall be measured and paid for at the respective unit price of the appropriate HMA Pavement item.

Cleaning and Bond Coat application- Cleaning and bond coat application shall be performed in accordance with Sections 501.03.C and 501.03.D of the 2012 MDOT Standard Specifications for Construction, except as modified herein, and as directed by the Engineer.

The Contractor shall furnish and operate throughout the construction period, vacuum-type street cleaning and utility structure cleaning equipment (Vac-All, Vactor, etc.) approved by the Engineer, and when directed by the Engineer, for street cleaning immediately prior to, and for street and utility structure cleaning after any and all paving. The cleaning equipment shall be of sufficient power to remove dust, dirt, and debris from the pavement and from utility structures in and adjacent to the construction area. The vac-all or similar equipment and shall be approved by the Engineer prior to beginning the work. The equipment used shall have an effective means for preventing any dust resulting from the operation from escaping into the air.

The bond coat shall be applied at a minimum rate of 0.05 gallons/yd². Before placing the bond coat, the existing pavement surface shall be thoroughly cleaned. The Contractor shall also thoroughly clean all joints, cracks, and edges to a minimum depth of one inch with compressed air, vac-all type equipment, or other approved mechanical or hand methods, to remove all dirt, debris, and all foreign material.

HMA Placement- Placement shall conform to Section 501.03.F of the 2012 MDOT Standard Specifications, except as modified herein, and as directed by the Engineer.

HMA placement shall not commence until a “Permit to Place” (no additional costs are required to obtain this permit) has been issued in writing by the Engineer. The Permit to Place shall be issued after the aggregate base course or the adjacent, underlying layer of pavement section has been approved by the Engineer.

The final structure adjustments must be approved by the Engineer prior to the issuance of the “Permit to Place” for the top course.

**DETAILED SPECIFICATION
FOR
ITEM #270 – HMA, 5E3 - PAVEMENT TOP AND LEVELING COURSES
ITEM #271 – HMA, 3C - PAVEMENT BASE COURSE
ITEM #272 – HMA, LVSP - PAVEMENT LEVELING COURSE
ITEM #273 – HMA, LVSP - PAVEMENT TOP COURSE
ITEM #274 – HMA, 36A - PAVEMENT TOP COURSE**

3 of 5

The top course shall be placed with a ¼” lip at the gutter edge of metal.

All HMA thickness dimensions are compacted-in-place.

Paving Operation Scheduling – The Contractor shall schedule the paving operation to avoid longitudinal cold joints that would be required to be left “open” over night.

In all cases, the Contractor shall pave the primary road’s through-traffic lanes (“main line”) first, from point-of-beginning to the point-of-ending. All other paving including, but not limited to; acceleration and deceleration lanes, intersection approaches, and center left-turn lanes shall be paved following completion of main line paving, unless authorized by the Engineer prior to the placement of any pavement.

Rate of Paver operation - The rate of the paver’s travel shall be maintained such that the paving operation will be continuous, resulting in no transverse cold joints, but shall never exceed the rate of 50 feet per minute.

The Contractor shall furnish and operate enough material, equipment, and hauling units so as to keep the paving machine(s) moving continuously at all times. Failure to do so shall be cause for the suspension of the paving operation until the Contractor can demonstrate to the satisfaction of the Engineer, that sufficient resources have been dedicated to perform the work in accordance with the project specifications.

Longitudinal and Transverse Joints- shall conform to Section 502.03.F of the 2012 MDOT Standard Specifications for Construction and as specified herein.

For mainline HMA paving, the width of the mat for each pass of the paver shall be not less than 10.5’, nor greater than 15’, except as noted in the plans and as directed by the Engineer. The Engineer will direct the layout of all HMA longitudinal joints during construction.

Prior to placing the adjacent paving pass on the leveling and top courses of HMA, the Contractor shall cut and remove 6” to 8” of the previously placed pavement at the free edge of the pavement by means of a coulter wheel. The Engineer reserves the right to reject any method(s) for cutting the pavement that does not provide a vertical and satisfactory edge, free of tearing, bending, or other deformations, as determined by the Engineer. Any method(s) employed by the Contractor shall be completely effective. The cut edge shall have a uniform bead of pavement joint adhesive applied to the full-height of the joint. The removal of this HMA material and resulting edge must be approved by the Engineer prior to proceeding with the placement of the succeeding pass of HMA. The base course of HMA and its vertical edge will have bond coat applied in accordance with Section 501.03.D. All costs associated with complying with these requirements will not be paid for separately, but shall be considered to be included in the HMA items of work.

Pavement joint adhesive shall be hot-applied, meet, or exceed, the following properties, and be approved by the Engineer prior to performing HMA placement:

**DETAILED SPECIFICATION
FOR
ITEM #270 – HMA, 5E3 - PAVEMENT TOP AND LEVELING COURSES
ITEM #271 – HMA, 3C - PAVEMENT BASE COURSE
ITEM #272 – HMA, LVSP - PAVEMENT LEVELING COURSE
ITEM #273 – HMA, LVSP - PAVEMENT TOP COURSE
ITEM #274 – HMA, 36A - PAVEMENT TOP COURSE**

4 of 5

Brookfield Viscosity, 400°F, ASTM D2669 – 4,000 to 10,000 cp
Cone Penetration, 77°F, ASTM D5329 – 60 to 100
Flow, 140°F, ASTM D5329 – 5mm maximum
Resilience, 77°F, ASTM D5329 – 30% minimum
Ductility, 77°F, ASTM D113 – 30 cm minimum
Ductility, 39.2°F, ASTM D113 – 30 cm minimum
Tensile Adhesion, 77°F, ASTM D5329 – 500% minimum
Softening Point, ASTM D36 - 170°F minimum
Asphalt Compatibility, ASTM D5329 – pass

Feather Joints – shall be constructed so as to vary the thickness of the HMA from zero inches to the required paving thickness at the rate of approximately 1.5” over a distance of 10 feet, or as directed by the Engineer. The Contractor shall rake the larger pieces of aggregate out of feather joints prior to compaction.

Butt Joints - Construction of butt joints, where directed by the Engineer, shall conform to Section 501.03.C.3 and 501.03.C.4 of the 2012 MDOT Standard Specifications for Construction, except as modified herein.

When a butt joint is specified or directed to be placed by the Engineer, remove the existing HMA surface to the thickness of the proposed overlay, or full-depth, as directed by the Engineer, for the full width or length of the joint. The HMA material shall be sawcut to the directed depth along the pavement edge or removal line to prevent tearing of the pavement surface. Cut joints that will be exposed in the completed surface must be cut with a saw or a cold-milling machine or other methods approved by the Engineer. Joints that will be covered by HMA must be cut with a saw, a cold-milling machine, or other methods approved by the Engineer.

Rakers- the Contractor shall provide a minimum of two rakers during the placement of all top and leveling courses.

Faulty Mixtures – The Contractor and Engineer shall carefully observe the paving operation for signs of faulty mixtures. Points of weakness in the surface shall be removed or corrected by the Contractor, at his/her sole expense, prior to paving subsequent lifts of HMA material. Such corrective action may include the removal and replacement of thin or contaminated sections of pavement, segregated HMA, and any sections that are weak or unstable. Once the Contractor or his representative is notified by the Engineer that the material being placed is out of allowable tolerances, or that there is a problem with the paving operation, the Contractor shall stop the paving operation at once, and shall not be permitted to continue placing HMA material until again authorized by the Engineer. Any costs associated with meeting the requirements specified herein shall not be paid for separately, but shall be included in the item(s) of work being performed at the time the faulty mixture was discovered.

**DETAILED SPECIFICATION
FOR
ITEM #270 – HMA, 5E3 - PAVEMENT TOP AND LEVELING COURSES
ITEM #271 – HMA, 3C - PAVEMENT BASE COURSE
ITEM #272 – HMA, LVSP - PAVEMENT LEVELING COURSE
ITEM #273 – HMA, LVSP - PAVEMENT TOP COURSE
ITEM #274 – HMA, 36A - PAVEMENT TOP COURSE**

5 of 5

MEASUREMENT AND PAYMENT

Measurement of these HMA paving items shall be by the ton, in place. Unused HMA remaining in trucks after the work is completed shall be returned to the plant and re-weighed, and the corrected weight slip shall be provided to the Engineer. No payment will be made for the unused HMA material. All weight slips must include the type of mixture (codes are not acceptable), as well as vehicle number, gross weight, tare weight and net weight.

Corrective action shall be enforced as described at Division 5 of the 2012 MDOT Standard Specifications for Construction and will be based on the City's testing reports.

All costs for furnishing and operating vacuum-type street cleaning equipment, backhoes, jackhammers, and air compressors shall be included in the bid prices for these items of work or in the item of work "General Conditions, Modified, Maximum, \$_____".

All costs of meeting the requirements of this Detailed Specification shall be included in the bid prices for HMA items in the proposal and will not be paid for separately.

The completed work as measured for these items of work will be paid for at the Contract Unit Prices for the following Contract (Pay) Items:

<u>PAY ITEM</u>	<u>PAY UNIT</u>
HMA, 3C - Pavement Base Course	Ton
HMA, 5E3 - Pavement Top and Leveling Course	Ton
HMA, LVSP - Pavement Leveling Course	Ton
HMA, LVSP - Pavement Top Course	Ton
HMA, 36A - Pavement Top Course	Ton

The unit prices for these items of work shall include all labor, material, and equipment costs to perform all the work specified in the Standard Specifications and as modified by this Detailed Specification.

**DETAILED SPECIFICATION
FOR
ITEM #270 – CONCRETE CURB OR CURB & GUTTER - ANY TYPE
ITEM #271 – CONCRETE CURB OR CURB & GUTTER - ANY TYPE – HIGH EARLY
ITEM #272 – 4 INCH CONCRETE SIDEWALK
ITEM #273 – 6 INCH CONCRETE SIDEWALK OR RAMP
ITEM #274 – 6 INCH CONCRETE SIDEWALK, RAMP, DRIVE APPROACH – HIGH EARLY
ITEM #275 - CONCRETE TYPE M DRIVE OPENING - HIGH EARLY**

1 of 5

DESCRIPTION

This work shall consist of constructing concrete items including curb, gutter, curb and gutter, sidewalks, drive approaches, and drive openings, all of any type and/or dimensions, all of either regular, fibermesh reinforced, and/or high-early concrete, in accordance with Sections 801, 802, and 803 of the Michigan Department of Transportation (MDOT) 2012 Standard Specifications for Construction, except as specified herein, as shown on the Plans, as described in this Detailed Specification, and as directed by the Engineer.

The Contractor is responsible to construct all sidewalks, sidewalk ramps, curbs, and all other concrete items within ADAAG compliance. All sidewalks and curb ramps must be constructed in accordance with MDOT Standard Plan R-28-J or version of standard plan/detail in place at time of the bid letting if different.

In addition, all concrete items of work shall comply with the Detailed Specifications for Concrete Durability and Concrete Placement and Protection.

MATERIALS

Concrete mixtures shall be as follows (or as directed by the Engineer), and concrete materials shall meet the requirements specified in the referenced sections of the MDOT Standard Specifications for Construction:

<u>Item Description</u>	<u>Concrete Mixture</u>	<u>MDOT Section</u>
All Items, Except High Early	P1, 6 sack	601
All High Early Items	P-NC, 7 sack	601

CONSTRUCTION METHODS

General

Curb, gutter, curb and gutter, sidewalk, sidewalk ramps, drive openings, and drives shall be replaced the same day they are removed.

Concrete items, including sidewalk, non-integral curb/gutter, drives, and structure adjustments shall be completed prior to the placement of pavement.

All subgrade work shall be completed prior to placing concrete items, unless directed or approved by the Engineer.

The subbase shall be trimmed to final elevation before placing curb. Curb shall not be placed on a pedestal or mound.

**DETAILED SPECIFICATION
FOR
ITEM #270 – CONCRETE CURB OR CURB & GUTTER - ANY TYPE
ITEM #271 – CONCRETE CURB OR CURB & GUTTER - ANY TYPE – HIGH EARLY
ITEM #272 – 4 INCH CONCRETE SIDEWALK
ITEM #273 – 6 INCH CONCRETE SIDEWALK OR RAMP
ITEM #274 – 6 INCH CONCRETE SIDEWALK, RAMP, DRIVE APPROACH – HIGH EARLY
ITEM #275 - CONCRETE TYPE M DRIVE OPENING - HIGH EARLY**

2 of 5

The Contractor shall excavate, cut, remove stumps, remove brush, remove pavement, grade, and trim as needed and as directed, and shall import, furnish, fill, place, grade, and compact Class II granular material and 21AA Aggregate material as needed to: construct new concrete items; to repair or replace existing concrete items; to relocate existing concrete items to their new specified/directed elevations/locations, including all necessary grading at elevation changes of curb and gutter, sidewalks and ramps; and at locations where existing concrete items are to be removed and turf is to be established in its place.

At locations where the subgrade, subbase or base becomes either disturbed, saturated or otherwise damaged, and where directed by the Engineer, the Contractor shall remove a minimum 6-inch thick layer of the subgrade, subbase or base, and replace it with approved 21AA Aggregate material, compacted in place.

The Contractor shall coordinate with the City Forester prior to the removal of any tree roots.

The Contractor is responsible for any damage to concrete items, including but not limited to vandalism; vehicular, pedestrian and/or miscellaneous structural damage; surface texture damage; and rain damage.

The Contractor shall maintain on-site at all times, a sufficient quantity of adequate materials to protect concrete items. The Engineer may suspend or defer concrete placement if rain protection is not available. The Contractor shall not be entitled to any additional compensation due to work suspension or deferral resulting from a lack of adequate rain protection.

The Contractor shall perform full-depth saw cutting at removal limits, including those necessary to construct 2-foot wide Type M drive openings, and including those necessary to provide for the partial removal of existing drive approaches, as shown on the Plans, as directed by the Engineer, and as marked for removal.

The subbase and adjacent concrete shall be sufficiently wet-down with water prior to placing concrete, to prevent water loss from the new concrete, and to form a better bond between old and new concrete. If a cold-joint becomes necessary, the existing concrete surface(s) shall be cleaned with compressed air to expose the aggregate in the concrete.

Where it is necessary to remove existing pavement to provide space for concrete formwork, a sufficient amount of the existing pavement shall be removed to allow for the use of a vibratory plate compactor in front of the curb.

Where concrete items are placed in areas adjacent to existing pavement that is beyond the general resurfacing (pavement removal and/or milling) limits, the adjacent pavement area shall be backfilled and permanently patched within 48-hours of the removal of concrete formwork. The backfill material shall be

MDOT 21AA aggregate compacted in place to 95%, up to the elevation of the proposed bottom of pavement. The pavement patching material(s) shall be as specified and as directed by the Engineer.

**DETAILED SPECIFICATION
FOR
ITEM #270 – CONCRETE CURB OR CURB & GUTTER - ANY TYPE
ITEM #271 – CONCRETE CURB OR CURB & GUTTER - ANY TYPE – HIGH EARLY
ITEM #272 – 4 INCH CONCRETE SIDEWALK
ITEM #273 – 6 INCH CONCRETE SIDEWALK OR RAMP
ITEM #274 – 6 INCH CONCRETE SIDEWALK, RAMP, DRIVE APPROACH – HIGH EARLY
ITEM #275 - CONCRETE TYPE M DRIVE OPENING - HIGH EARLY**

3 of 5

Where concrete items are placed adjacent to existing pavement that is within areas scheduled for subsequent pavement removal and/or milling, the adjacent pavement area shall, within 48-hours of the removal of concrete formwork, be backfilled with MDOT 21AA aggregate compacted in place to 95% up to the elevation of the bottom of the adjacent pavement.

Prior to compacting backfill in front of curb and gutter, the back of curb shall be backfilled with approved material and compacted by mechanical means to 95%.

At various times throughout the work, the Engineer may direct the Contractor to use smaller and/or lighter equipment, and to defer certain work tasks, in order to protect the grade and/or adjacent areas. The Contractor shall not be entitled to any additional compensation for the use of smaller equipment, lighter equipment, or work task deferral.

Restoration

The Contractor shall restore all disturbed areas to better than or equal to their original condition within two calendar days from the date of concrete placement. This includes the placement and compaction of 2.5 inches of topsoil, followed by the placement of grass seed, followed by the placement of 0.5 inches of topsoil, at all turf restoration locations, and at locations where concrete items are removed and turf is to be established. Restoration shall also include the replacement of any brickwork, decorative stone, or other adjacent materials. All restoration work and materials shall be in accordance with the City of Ann Arbor Standard Specifications for Construction.

Contraction Joints in Sidewalk

Contraction joints shall be placed at 5-foot intervals and may be tooled or sawed. The method of forming joints and spacing shall be approved by the Engineer prior to construction.

Expansion Joints in Sidewalks

$\frac{3}{4}$ -inch wide expansion joints shall be placed through concrete sidewalks in line with the extension of all property lines, at all expansion joints in the abutting curb, gutter, and combination curb and gutter, and as directed by the Engineer. Transverse expansion joints shall be placed through the sidewalks at uniform intervals of not more than 300-feet.

$\frac{1}{2}$ -inch wide expansion joints shall be placed between the sidewalk and back of abutting curb or gutter, at the juncture of two sidewalks, between the sidewalk and buildings and other rigid structures, and as directed by the Engineer.

Expansion Joints in Curb and Gutter

$\frac{3}{4}$ -inch wide expansion joints shall be placed at all street returns, at all expansion joints in an abutting pavement, at each side of all driveways (at radius points), elsewhere at 300-foot maximum intervals, and as directed by the Engineer.

Expansion joint material shall extend to the full depth of the joint. After installation, the top shall not be above the concrete nor be more than $\frac{1}{2}$ -inch below it. No reinforcing steel shall extend through expansion joints.

**DETAILED SPECIFICATION
FOR
ITEM #270 – CONCRETE CURB OR CURB & GUTTER - ANY TYPE
ITEM #271 – CONCRETE CURB OR CURB & GUTTER - ANY TYPE – HIGH EARLY
ITEM #272 – 4 INCH CONCRETE SIDEWALK
ITEM #273 – 6 INCH CONCRETE SIDEWALK OR RAMP
ITEM #274 – 6 INCH CONCRETE SIDEWALK, RAMP, DRIVE APPROACH – HIGH EARLY
ITEM #275 - CONCRETE TYPE M DRIVE OPENING - HIGH EARLY**

4 of 5

Plane of Weakness Joints in Curb and Gutter

Intermediate plane of weakness joints shall be placed to divide the structure into uniform sections, normally 10-feet in length, with a minimum being 8-feet in length, and shall be placed opposite all plane of weakness joints in the abutting concrete base course.

Plane of weakness joints shall be formed by narrow divider plates, which shall extend 3-inches into the exposed surfaces of the curb or curb and gutter. Plates shall be notched, if necessary, to permit the steel reinforcement to be continuous through the joint.

MEASUREMENT AND PAYMENT

The work of furnishing and installing mechanical anchors and hook bolts will be measured and paid for by the number of hook bolts installed.

All concrete pavement repair, including that which is installed with integral curb and gutter, will be measured and paid for by the area actually placed in square yards (SY).

No additional compensation will be paid for the construction of concrete items adjacent to existing concrete curb, gutter, pavement, or any other pavement or surface feature(s).

No additional compensation will be paid for the removal of a 6-inch thick layer of the subgrade, subbase or base, and replacement with approved 21AA aggregate material, compacted in place.

A deduction in length for catch basins and inlet castings will be made to measurements of Curb and Gutter.

Curb, gutter, and curb and gutter shall be paid as "Concrete Curb or Curb & Gutter – Any Type, Modified".

Restoration work, including backfilling, compacting, HMA patching adjacent to concrete items, topsoiling and seeding will not be paid for separately, but shall be included in the appropriate associated items of work.

Payment for saw cutting for Type M openings and for partial removal of existing drives shall be included in the price for the item of work, "Remove Concrete Sidewalk, Ramp and Drives - Any Thickness, Modified", and will not be paid for separately.

Payment for the removal of HMA pavement and aggregate base to provide space for concrete formwork and vibratory plate compactor shall be included in the price for the item of work, "Remove Concrete Curb or Curb and Gutter - Any Type, Modified", and will not be paid for separately.

**DETAILED SPECIFICATION
FOR
ITEM #270 – CONCRETE CURB OR CURB & GUTTER - ANY TYPE
ITEM #271 – CONCRETE CURB OR CURB & GUTTER - ANY TYPE – HIGH EARLY
ITEM #272 – 4 INCH CONCRETE SIDEWALK
ITEM #273 – 6 INCH CONCRETE SIDEWALK OR RAMP
ITEM #274 – 6 INCH CONCRETE SIDEWALK, RAMP, DRIVE APPROACH – HIGH EARLY
ITEM #275 - CONCRETE TYPE M DRIVE OPENING - HIGH EARLY**

5 of 5

Completed work as measured for these items of work will be paid for at Contract Unit Prices for the following Contract (Pay) Items:

<u>PAY ITEMS</u>	<u>PAY UNIT</u>
Concrete Curb or Curb & Gutter	Linear Foot
4” or 6” Concrete Sidewalk, Ramp, or Drive Approach	Square Foot
Concrete Type M Drive Opening, High Early	Linear Foot

The unit prices for these items of work shall include all labor, material, and equipment costs to perform all the work specified in the Standard Specifications and as modified by this Detailed Specification.

**DETAILED SPECIFICATION
FOR
ITEM #276 – DETECTABLE WARNING, CAST IN PLACE**

DESCRIPTION

This work shall consist of furnishing and installing cast in place detectable warning units in compliance with the Americans with Disability Act (ADA). All work shall be in accordance with MDOT Standard Detail R-28-J (or version in place at time of the bid letting).

MATERIALS

The detectable warning tiles shall be colored as Federal Number 22144 (variously referred to as “Clay Red” or “Brick Red”). The detectable warning tiles shall meet the following material properties, dimensions, and tolerances using the most current test methods:

1. Water Absorption: Not to exceed 0.35% when tested in accordance with ASTM-D570
2. Slip Resistance: 0.80 minimum combined wet/dry static coefficient of friction on top domes and field area, when tested in accordance with ASTM C1028.
3. Compressive Strength: 18,000 psi minimum, when tested in accordance with ASTM D695.
4. Tensile Strength: 10,000 psi minimum, when tested in accordance with ASTM D638.
5. Flexural Strength: 24,000 psi minimum, when tested in accordance with ASTM D790.
6. Chemical Stain Resistance: No reaction to 1% hydrochloric acid, urine, chewing gum, soap solution, motor oil, bleach, calcium chloride, when tested in accordance with ASTM D543 or D1308.
7. Wear Depth: 300 minimum, when tested in accordance with ASTM C501.
8. Flame Spread: 25 maximum, when tested in accordance with ASTM E84.
9. Gardner Impact: 50 in.-lbs. minimum, when tested in accordance with Geometry “GE” of ASTM D5420.
10. Accelerated Weathering of Tile when tested by ASTM-G155 or ASTM G151 shall exhibit the following result- $\Delta E < 6.0$ as well as no deterioration, fading or chalking of surface when exposed to 3000 hours minimum exposure.
11. Wheel Loading: The cast in place tile shall be mounted on a concrete platform with a ½” airspace at the underside of the tile top plate then subjected to the specified maximum load of 10,400 lbs., corresponding to an 8,000 lb individual wheel load and a 30% impact factor. The tile shall exhibit no visible damage at the maximum load of 10,400 lbs using AASHTO-HB17 single sheet HS20-44 loading “Standard Specifications for Highways and Bridges.”
12. Salt and Spray Performance of Tile and Adhesive System when tested to ASTM-B117 not to show any deterioration or other defects after 100 hours of exposure

CONSTRUCTION METHODS

Installer’s Qualifications: Engage an experienced Installer who has successfully completed tile installations similar in material, design, and extent to that indicated for this Project.

The contractor shall follow manufacturer specifications for installation, except where they conflict with MDOT Standard Detail R-28-J (or version in place at the time of bidding), or other project requirements.

MEASUREMENT AND PAYMENT

The completed work as measured for this item of work will be paid for at the Contract Unit Prices for the following Contract (Pay) Item:

PAY ITEM

PAY UNIT

Detectable Warning, Cast in Place

Square Foot

The unit price for this item of work shall include all labor, material, and equipment costs to perform all the work specified in the Standard Specifications and as modified by this Detailed Specification.

**DETAILED SPECIFICATION
FOR
BASKETBALL POLE ASSEMBLY RE-USE**

DESCRIPTION

The Basketball pole assembly includes the foundation, pole, backboard, rim, net and all hardware. The Contractor may choose to remove, protect, and reuse the westerly basketball pole assembly within the area of sewer construction influence. The easterly basketball pole assembly shall remain in place and be protected from damage during construction. The contractor shall replace with new equipment the assemblies, or any parts, that are damaged during construction at no additional cost to the project.

MEASUREMENT AND PAYMENT

All costs for removal, protection, replacement of basketball pole assemblies shall not be paid separately, but shall be included in the bid price for Clean Up and Restoration, Special.

**DETAILED SPECIFICATION
FOR
BASKETBALL COURT COLOR COATING**

DESCRIPTION

The work covered by this specification consists of furnishing all labor, equipment and materials, and performing all operations in connection with color coating and striping.

Contractor is to examine the existing court and replicate all colors and line work.

Prior to applying color coat system, the basketball pole assemblies shall be installed by Contractor. New asphalt shall be allowed to cure for 30 days prior to application of color coat.

Any depressions or "bird baths" that cover a nickel shall be marked and repaired with acrylic patch mix. Surfaces shall be broom cleaned, power washed or prepared sufficiently to receive color coating materials as per manufacturer's requirements.

MATERIALS

1. Acrylic Resurfacer – 1 coat. Surface shall be uniform texture, clean and free of grease, oils and other foreign materials. Mix shall be the following: 55 gallons acrylic resurfacer, 20-40 gallons water, 600-900 lbs sand. The application rate shall be 0.05 to 0.07 gallons per square yard.
2. Fortified Plexi-pave – 2 coats. First coat shall be applied at a rate of 0.1 to 0.07 gallons per square yard. Second coat shall be applied at a rate of 0.05 to 0.07 gallons per square yard.
3. Line Paint. All 2-inch lines are to be taped on each side of line and laid out as they exist now. Paint is to be acrylic latex striping.
4. Color shall be blue inside the four keys and green on the open courts and to the edge of asphalt. Colors shall be approved by City prior to application.

MEASUREMENT AND PAYMENT

All costs for coating the basketball court shall not be paid separately, but shall be included in the bid price for Clean Up and Restoration, Special.

**DETAILED SPECIFICATION
FOR
COORDINATION AND COOPERATION WITH OTHERS
AND
WORK BY OTHERS**

The Contractor is reminded as to the requirements of article 104.07 of the 2012 edition of the MDOT Standard Specifications, "Cooperation by the Contractor."

The Contractor shall directly coordinate his/her work with individual City Departments/Divisions/Units.

The Contractor is hereby notified that the City of Ann Arbor Field Services Unit may be installing traffic control conduits, traffic signal sensors, and the like, at various locations.

No additional compensation will be paid to the Contractor, and no adjustments to contract unit prices will be made, due to delays and/or the failure of others in the performance of their work, nor for delays due to the encountering of existing utilities that are, or are not, shown on the Plans.

The following Utility Owners, and others not listed specifically, may have overhead and/or underground facilities located within the Right-of-Way/Public Easements:

The City of Ann Arbor
University of Michigan (UM)
Michigan Department of Transportation (MDOT)
AT&T
Comcast
DTE Energy - Detroit Edison Company (Edison)
DTE Energy - Michigan Consolidated Gas Company (Michcon)
Fiber Link Inc.
Light Core (Century Tel)
MCI Communications
Windstream Communications

On all projects:

"3 Working Days before you Dig - Call MISS DIG - Toll Free" Phone No. 1-800-482-7171.

The Owners of public or private utilities which will not interfere with the completed project and which do not present a hazard to the public or an extraordinary hazard to the Contractor's operations will not be required to move their facilities on or from the street right-of-way.

Stoppages created solely by the operations of the utility companies which delay utility revisions on any portion of this project may be considered as a basis of claim for an extension of time for project completion.

Costs for this work will not be paid for separately, but shall be included in the bid price of the Contract Item "General Conditions, Modified, Maximum, \$_____".

**DETAILED SPECIFICATION
FOR
GENERAL CONSTRUCTION NOTES**

The following notes pertain to all Plan sheets issued as part of this Contract, and these notes shall be considered part of each Plan sheet or Detailed Information Sheet.

1. All work shall conform to latest revision of the City Standard Specifications.
2. The Contractor shall maintain access to all drives throughout the course of construction. Drives shall never be closed during non-working hours, unless otherwise authorized in writing by the Engineer.
3. The Contractor shall completely restore all existing site features to better than, or equal to, their existing condition.
4. The Contractor shall be aware that there are above-ground and below-ground utilities existing in and on these streets which include, but are not limited to: gas mains and service leads; water mains and service leads; storm sewer mains and service leads; sanitary sewer mains and service leads; telephone poles, wires, cables and conduits; electrical poles, wires, cables and conduits; cable television wires, cables and conduits, and other various utilities. The Contractor shall conduct all of its work so as not to damage or alter in any way, any existing utility, except where specified on the Plans or where directed by the Engineer. The City has videotaped and cleaned all sanitary and storm sewers, including storm sewer inlet leads, and has found all of these facilities to be in good condition, with the exception of those shown on the Plans for repairs or replacement.
5. The Contractor is solely responsible for any delays, damages, costs and/or charges incurred due to and/or by reason of any utility, structure, feature and/or site condition, whether shown on the Plans or not, and the Contractor shall repair and/or replace, at its sole expense, to as good or better condition, any and all utilities, structures, features and/or site conditions which are impacted by reason of the work, or injured by its operations, or injured during the operations of its subcontractors or suppliers.
6. No extra payments or adjustments to unit prices will be made for damages, delays, costs and/or charges due to existing utilities, structures, features and/or site conditions not shown or being incorrectly shown or represented on the Plans.

**DETAILED SPECIFICATION
FOR
DISPOSING OF EXCAVATED MATERIAL**

The Contractor shall dispose of, at the Contractor's expense, all excavated material. Costs for this work will not be paid for separately, but shall be included in the bid price of the Contract Item "General Conditions, Modified, Maximum, \$_____".

**DETAILED SPECIFICATION
FOR
PROTECTION OF UTILITIES**

Damages to utilities by the Contractor's operations shall be repaired by the utility owner at the Contractor's expense.

Delays to the work due to utility repairs are the sole responsibility of the Contractor.

The Contractor shall keep construction debris out of utilities at all times. The Contractor shall be back charged an amount of \$50.00 per day for each manhole/inlet/utility pipe that contains construction debris caused as a result of the Contractor's (including subcontractors and suppliers) work.

The Contractor is solely responsible for any damages to the utilities or abutting properties due to construction debris.

Certain sanitary and storm sewers within the influence of construction may have been cleaned and videotaped prior to construction. The City may also choose to videotape utility line(s) during or after the work of this Contract to inspect them for damages and/or construction debris. If such inspection shows damage and/or debris, then all costs of such inspection, cleaning, repairs, etc, shall be the Contractor's sole responsibility. If such inspection is negative, the City will be responsible for the costs of such inspection.

Costs for this work will not be paid for separately, but shall be included in the bid price of the Contract Item "General Conditions, Modified, Maximum, \$_____".

**DETAILED SPECIFICATION
FOR
SOIL EROSION AND SEDIMENTATION CONTROL MEASURES**

The Contractor shall furnish, place, maintain and remove soil erosion and sedimentation control measures, in accordance with all applicable City (and other governmental agencies) codes and standards, as directed by the Engineer, as detailed in the Standard Specifications, and as required to maintain compliance.

Costs for this work, other than specifically identified in the bid items, will not be paid for separately, but shall be included in the bid price of the Contract Item "General Conditions, Maximum, \$_____".

**DETAILED SPECIFICATION
FOR
VACUUM TYPE STREET AND UTILITY STRUCTURE CLEANING EQUIPMENT**

The Contractor shall furnish and operate throughout the construction period, vacuum type street cleaning and utility structure cleaning equipment (Vac-All, Vactor, etc.) approved by the Engineer, as and when directed by the Engineer for dust control, for dirt/debris control, and for street cleaning immediately prior to, and for street and utility structure cleaning after any and all paving. The cleaning equipment shall be of sufficient power to remove dust, dirt, and debris from the pavement and from utility structures in and adjacent to the construction area.

Costs for this work will not be paid for separately, but shall be included in the bid price of the Contract Item "General Conditions, Maximum, \$_____".

**DETAILED SPECIFICATION
FOR
MATERIALS AND SUPPLIES CERTIFICATIONS**

The following materials and supplies shall be certified by the manufacturer or supplier as having been tested for compliance with the Specifications:

- HMA materials
- Hot-poured Joint Sealants
- Cements, coatings, admixtures and curing materials
- Sands and Aggregates
- Steel and Fabricated metal
- Portland Cement Concrete Mixtures
- Reinforcing Steel for Concrete
- Reinforcing Fibers for Concrete
- Pre-cast Concrete products
- Sanitary Sewer Pipe
- Storm Sewer Pipe
- Water Main Pipe
- Corrugated Metal Pipe
- High Density Polyethylene Pipe
- Timber for retaining walls
- Modular Concrete Block for retaining walls
- Edge Drain and Underdrain Pipe
- Geotextile Filter Fabric and Stabilization Fabric/Grids

The Contractor shall submit all certifications to the Engineer for review and approval a minimum of three business days prior to any scheduled delivery, installation, and/or construction of same.

Costs for this work will not be paid for separately, but shall be included in the bid price of the Contract Item "General Conditions, Maximum, \$_____".

**DETAILED SPECIFICATION
FOR
CONTRACT DRAWINGS/PLANS**

Bidders shall carefully check and review all Drawings, plans, and specifications, and advise the Engineer of any errors or omissions discovered. The Drawings/Plans may be supplemented by such additional Drawings/Plans and sketches as may be necessary or desirable as the work progresses. The Contractor shall perform all work shown on any additional or supplemental Drawings/Plans issued by the Engineer.

Bidders shall carefully examine the Bid Form, preliminary layouts, specifications, and the work sites until the Bidder is satisfied as to all local conditions affecting the contract and the detailed requirements of construction. The submission of the bid shall be considered prima facie evidence that the Bidder has made such examination and is satisfied as to the conditions to be encountered in performing the work and all requirements of the contract.

**DETAILED SPECIFICATION
FOR EXISTING
SOIL BORING AND PAVEMENT SECTION DATA**

Data pertaining to existing soil borings and pavement sections which may be included in these Contract Documents are provided to help the Engineer and Contractor determine the soil conditions existing within the construction area. The City in no way guarantees existing conditions to be the same as shown in the data. The Contractor is solely responsible for any and all conclusions he/she may draw from the data.

**DETAILED SPECIFICATION
FOR
WORKING IN THE RAIN OR IN THE DARK**

Working in the Rain

The Contractor shall not work in the rain unless authorized in writing by the Engineer.

The Engineer may delay or stop the work due to threatening weather conditions.

The Contractor shall not be compensated for unused materials or downtime due to rain, or the threat of rain.

The Contractor is solely responsible for repairing all damages to the work and to the site, including road infrastructures, road subgrades, and any adjacent properties, which are caused as a result of working in the rain.

Working in the Dark

The Contractor shall not work in the dark except as approved by the Engineer.

The Engineer may stop the work, or may require the Contractor to defer certain work to another day, if, in the Engineer's opinion, the work cannot be completed within the remaining daylight hours, or if inadequate daylight is present to either properly perform or inspect the work.

The Contractor will not be compensated for unused materials or downtime, when delays or work stoppages are directed by the Engineer for darkness and/or inadequate remaining daylight reasons.

The Contractor is solely responsible for repairing all damages to the work and to the site,

Including road infrastructures, road subgrades, and any adjacent properties, which are caused as a result of working in the dark.

**DETAILED SPECIFICATION
FOR
QUANTITIES AND UNIT PRICES**

Quantities as given are approximate and are estimated for bidding purposes. Quantities are not guaranteed and may vary by any amount. While it is the City's intent to complete the project substantially as drawn and specified herein, quantities may be changed or reduced to zero for cost savings or other reasons. **The City reserves the right to change the quantities, delete work, or add work, and no adjustment in unit price will be made for any change in any quantity.**

**DETAILED SPECIFICATION
FOR
WATER MAIN INSTALLATION AND TESTING**

DESCRIPTION

This Detailed Specification is intended to supplement the current City of Ann Arbor Standard Specifications for Construction with regard to water main installation and hydrologic and bacteriologic testing. It is also intended to establish minimum requirements for the work that the Contractor is responsible to follow.

CONSTRUCTION METHODS

During the delivery, handling, installation, and testing of the water main, the Contractor shall comply with the following requirements:

1. Keep all pipes clean and neatly stacked a minimum of six-inches off of the ground at all times. Ends of pipe shall be covered to prevent entry of dust, dirt, small animals, and any other objectionable matter at all times. During installation of the water main and all appurtenances no dirt, soil, or non-potable water shall be allowed to enter the pipe. If dirt, soil, or non-potable water does enter the pipe, the Contractor shall completely remove it prior to installing the next segment of pipe. Segments of pipe that have visible signs of contamination including, but not limited to; soil, dirt, mud, oil, grease, solvents, animal droppings, etc. shall have all visible traces of the offending substance completely removed by the Contractor in a manner acceptable to the Engineer. Sections of pipe or fittings that have been marked by the Engineer for cleaning shall not be approved for installation until such time as the Engineer has again approved them for use on the project. Acceptable methods of cleaning include flushing and/or power washing, compressed air, or other methods that the Engineer may approve. Approval by the Engineer of a cleaning method shall not be construed by the Contractor to include acceptance of the water main for the purposes of placing it into service. Water main pipe and fittings that have been placed shall remain covered on the advancing end until the next segment of pipe is connected. The Contractor may uncover no more than three segments of pipe in advance of placement. Water main pipe and fittings that have been laid out further in advance of the installation operation must remain covered.
2. Gasket lubricant shall only be applied immediately before connection to the next segment of pipe. Pipe with lubricant applied shall not come in contact with the ground. If the lubricated portion of the pipe end contacts the ground, it shall be thoroughly cleaned to the satisfaction of the Engineer, prior to its installation.
3. All water mains shall be swabbed in accordance with the requirements of Section 3H, Flushing and Swabbing, of the current edition of the City of Ann Arbor Public Services Department Standards. During swabbing of the water main, the swab shall be flushed through the pipe in accordance with the manufacturer's recommendations and in a manner that is acceptable to the Engineer. The Contractor shall submit the product data of the swab from the manufacturer, for review and approval by the Engineer, at or before the pre-construction meeting.
4. Swabbing of the water main shall be followed immediately by flushing of the pipe so that any disturbed particles are washed out before they can resettle. The pipe shall be flushed in accordance with Section 3H, Flushing and Swabbing, of the current edition of the City of Ann Arbor Public Services Department Standard Specifications. The pipe shall be flushed until the water runs clear for a minimum of fifteen minutes or until two full pipe volumes have been flushed (whichever is longer.) Flushing from the existing water main that is to be replaced shall not be allowed.
5. During the chlorination process, the proper level of chlorination must be achieved throughout the entire length pipe. Chlorine levels shall be checked at intermediate locations as directed by the Engineer and the Contractor shall add chlorine until such time as the required levels are achieved at all points. The "plug method" of chlorinating the pipe shall not be allowed. The Contractor shall chlorinate the proposed water main to a minimum residual concentration of 100 parts per million with commercial liquid chlorine solution. The chlorine concentrate shall be a minimum of 10% chlorine (sodium hypochlorite) by volume. Solid chlorine "pellets" or powder shall not be allowed. Any chlorine containing compound used on the project shall be approved by the Engineer. The minimum recommended dosage of chlorine (sodium hypochlorite) is as follows (based on 10%

available chlorine):

Recommended Minimum Chlorine Dosage to Disinfect 100 L.F. of Pipe

<u>Pipe Diameter</u>	<u>10% Chlorine Solution (gallons)</u>
6	0.306
8	0.544
10	0.852
12	1.226
16	2.180
20	3.406
24	4.904

6. Bacteriological testing shall be performed by the City with the Contractor present. The Engineer shall determine the number, location, and type of testing points for each section of water main being tested. Bacteriological samples shall only be drawn from copper or brass sampling points. The use of galvanized steel blow-offs or sampling points are strictly prohibited. Obtaining bacteriological samples from fire hydrants will not be allowed.
7. If a new water main fails two consecutive sets of bacteriological tests, the Engineer may require the Contractor to re-swab the water main in accordance with Section 3H, Flushing and Swabbing, as described above. Additional flushing, prior to subsequent bacteriological sampling will also be required. The required additional swabbing and flushing of the water main by the Contractor shall be performed at no additional cost to the City of Ann Arbor.

MEASUREMENT AND PAYMENT

Payment for all labor, materials, and equipment that is required to comply with this Detailed Specification shall be considered as part of the unit price as bid for each respective water main pipe and fitting and will not be paid for separately.

Payment for all water main pipes shall be as follows:

The Contractor shall be paid for 50% of the water main pipe installed upon satisfactory completion of the installation and backfilling of the water main pipe. The remaining 50% shall be paid upon successful completion of all required bacteriological testing, the water main has been placed into service, and all water service leads have been connected and are in service.

**DETAILED SPECIFICATION
FOR
ASPHALTIC SEAL COATINGS
DUCTILE IRON PIPE FITTINGS**

DESCRIPTION

The Contractor may not operate City water main valves. For valve operation, contact the City of Ann Arbor Public Services Area. It is recommended that the Contractor request that the existing valves, which will need to be operated in order to perform the water main work, are checked in advance of the work to ensure that they operate properly.

Several items of work on this project require coordination with the City of Ann Arbor Public Services Area (The City). The Contractor shall notify the City three (3) full working days in advance of any items requiring coordination with the City.

The Contractor shall complete the water main work in a manner which minimizes the disruption of water service. Water quality issues arise and treatment costs increase when the well field system is taken off line. No shut downs at the well field shall occur on Saturdays or Sundays. Shut downs shall not be for longer than 8.0 hours for any given shutdown event. Liquidated damages as detailed and described on page C-2 of these documents shall apply to any shut downs that occur on Saturday or Sunday or for a period of time longer than 8.0 hours in any given 24 hour period.

The Contractor shall be responsible for coordination with the City of Ann Arbor Public Services Area for the installation of 1-inch corporations in the gate wells to be used for testing and filling of new main. The Contractor shall pay the City of Ann Arbor's Field Operations Unit all costs associated with installing the corporations.

The Contractor must have all materials, fittings, pumps and other miscellaneous equipment, and personnel on site before the City of Ann Arbor Public Services Area personnel will prepare and shutdown an existing main.

The Contractor shall dig-up and expose utility crossings 60-feet in advance of laying any water main pipe in their vicinity. This will allow the Engineer to adjust the grade of the water main, if possible, to avoid the existing utilities. The costs of the advance excavations, and related costs, shall be included in the respective items of work listed in the Bid Form. Some dig-ups may need to occur out of Phase.

All ductile iron pipe and fittings shall have an asphaltic seal coat on their cement-mortar linings. The coatings shall meet the requirements of ANSI/NSF Standard 61, Drinking Water System Components - Health Effects, and be approved for contact with drinking water.

MEASUREMENT AND PAYMENT

Asphaltic seal coat for ductile iron pipe and fittings shall not be measured or paid for separately. This work shall include all labor, materials and equipment costs necessary to provide asphaltic seal coat of ductile iron pipe and fittings. Payment for this work shall be considered as part of the unit price for each respective ductile iron pipe and fitting unit price.

**DETAILED SPECIFICATION
FOR
CONCRETE DURABILITY**

1 of 6

DESCRIPTION

The Contractor shall furnish a Portland cement concrete mixture for this project that has been tested under this specification and shown to be resistant to excessive expansion caused by alkali-silica reactivity (ASR) and provides adequate air entrainment for freeze thaw durability. The Contractor shall construct the project with practices outlined in this specification.

MATERIALS

The materials provided for use on this project shall conform to the following requirements:

Portland cement	ASTM C 150
Fine Aggregate	ASTM C 33*
Coarse Aggregate	ASTM C 33*
Fly Ash, Class F	ASTM C 618
Slag Cement, Grade 100, 120	ASTM C 989
Silica Fume	ASTM C 1240
Blended Cements	ASTM C-595
Air Entraining Admixtures	ASTM C-260
Chemical Admixtures	ASTM C-494
White Membrane Cure	ASTM C-309 Type 2

* Fine and coarse aggregates shall consist of natural aggregates as defined in the Michigan Department of Transportation 2012 Standard Specifications for Construction Section 902.02.A.1.

The Contractor shall provide documentation that all materials to be incorporated into proposed mixed designs meet the requirements of this section.

Alkali-Silica Reactivity

The Contractor shall supply to the Engineer preliminary concrete mix designs including a list and location of all suppliers of concrete materials. The Contractor shall evaluate the mixtures for the potential for excessive expansion caused by ASR and provide documentation to the Engineer. The Contractor's evaluation shall include a review of any previous testing of the material sources intended to be used for both the fine and coarse aggregates for the concrete mixtures. The previous testing may be from other projects or records provided by the material suppliers.

Aggregates shall be tested under ASTM C-1260. If the expansion of the mortar bars is less than 0.10%, at 14 days, the aggregates shall be considered innocuous and there are no restrictions for ASR mitigation required with this material.

Previous aggregate test data may be used. If no previous test data is available, for the concrete mix, that shows that it is resistant to ASR, a concrete mixture that will mitigate the potential for ASR must be designed using either method 1 or 2 as described below.

Method 1. Substitution of a portion of the cement with Class F Fly Ash, Slag Cement Grade 100 or 120 or a ternary mix (blended cement) containing a blend of Portland cement and slag cement, or Class F fly ash, or silica fume.

**DETAILED SPECIFICATION
FOR
CONCRETE DURABILITY**

2 of 6

The maximum substitution of cement with the fly ash permitted shall be 25% by weight of total cementitious material (cement plus fly ash). Additional requirements for the Fly Ash, Class F are that the Calcium Oxide (CaO) percent shall be less than 10 % and the available alkalis shall not exceed a maximum of 1.5%. A copy of the most recent mill test report shall be submitted to verify. Note: a Class C fly ash with a minimum total oxides ($\text{SiO}_2 + \text{Al}_2\text{O}_3 + \text{Fe}_2\text{O}_3$) of 66% and a minimum SiO_2 of 38% may be used in lieu of Type F fly ash.

The maximum substitution of cement with the Slag Cement permitted shall be 40% by weight of total cementitious material (cement plus Slag Cement). The minimum replacement rate with Slag Cement shall be 25%.

For a ternary blend the total replacement of supplementary cementitious materials is 40% with a blend consisting of a maximum of 15% type F fly ash, and/or 8% silica fume and/or slag cement.

For method 1, the effectiveness of the proposed mix combination to resist the potential for excessive expansion caused by ASR shall be demonstrated using current or historic data. To demonstrate the effectiveness of the proposed mix the Contractor shall construct and test mortar bars per ASTM C1567 (14 day test) using both the fine and coarse aggregate along with the proposed cementitious material for the concrete mixture. If a mortar bar constructed of these materials produces an expansion of less than 0.10%, concrete mixture will be considered to be resistant to excessive expansion due to ASR.

If a mortar bar constructed produces an expansion of 0.10% or greater, concrete mixtures containing these materials shall not be considered resistant to the potential for excessive expansion due to ASR and shall be rejected. Additional testing, including alternate proportions or different materials will be required.

Method 2. Use low alkali cement and maintain the total alkali content from the cementitious at no more than 3.0 lbs/cyd (Na_2Oeq). The total alkali contribution is calculated by the quantity contained in the Portland cement only.

Requirements for Low Alkali Cement are that the alkali content does not exceed 0.60% expressed as Na_2O equivalent. Equivalent sodium oxide is calculated as: (percent Na_2O + 0.658 x percent K_2O).

For either method 1 or 2, if the Contractor intends to change any component material supplied after the mix design has been approved all concrete work will be suspended with no cost to the project or extensions of time, unless approved, until evaluation of the new mixtures and testing of the new materials demonstrates that it is resistant to excessive expansion due to ASR.

The Engineer and Contractor shall monitor the concrete that is delivered to the project site so as to insure that the approved mix design is being followed. The supplier shall include on the delivery ticket for each batch of concrete delivered to the job, the identification and proportions of each material batched.

When concrete is placed during cold weather, defined for the purposes of this Detailed Specification to be, air temperatures below 40° F, the use of accelerators, heated aggregates, silica fume and/or additional forms of cold weather protection will be required. Cold weather will not eliminate the requirement for furnishing and placing a concrete mix that is considered resistant to ASR attack.

Prior to cool weather placement, defined for the purposes of this detailed specification to be, air temperatures between 40° and 60° F, the set time of the proposed mix shall be verified under anticipated field conditions. This information shall be used when scheduling pours and saw crews.

**DETAILED SPECIFICATION
FOR
CONCRETE DURABILITY**

3 of 6

Prior to cool weather placement, defined for the purposes of this detailed specification to be, air temperatures between 40° and 60° F, the set time of the proposed mix shall be verified under anticipated field conditions. This information shall be used when scheduling pours and saw crews.

Air Entrainment

Air entrainment shall be accomplished by addition of an approved air entraining agent. Air content as determined by ASTM C 231 or ASTM C 173, shall be determined on each day of production as early and as frequently as necessary until the air content is consistently acceptable. If during the period of time while adjustments are being made to the concrete to create a mixture that is consistently acceptable, concrete is produced that does not meet the requirements of this Detailed Specification, the Engineer may reject the material and direct it to be removed from the jobsite. Any rejected material shall be removed from the jobsite at the Contractor's sole expense. Quality Control testing performed by the Contractor to ensure compliance with the project specifications shall be performed on the grade ahead of the placement operation.

Paver placement: During production, the plastic concrete material shall be tested for acceptance at a point ahead of the paver. The air content of the concrete mixture that the Contractor shall provide shall be known as the Acceptance Air Content (AAC). The Contractor shall also provide additional entrained air in the concrete mixture to account for the air loss which occurs in the concrete mixture experienced during transportation, consolidation and placement of the concrete. The "air loss" shall be added to the air content of the concrete mixture as established on the approved concrete mix design. The AAC for the project will be 6.0% plus an amount equal to the air loss.

For up to the first four loads, the air content measured on-site prior to placement shall be at least 8.0% and no more than 12.0%. To establish the initial AAC on the first day of paving, the air content of the first load shall be tested at the plant. After initial testing at the plant the Contractor shall provide at least two sample sets to determine the actual air loss during placement. A sample set shall consist of two samples of concrete from the same batch, one taken at the point of discharge and the other from the in-place concrete behind the paver. The air loss from the two sample sets shall be averaged and added to 6.0% to establish the AAC (rounded to the next higher 0.5%). After the testing and adjustment procedure(s) have been completed, the project acceptance air tests shall be taken prior to placement. The Contractor shall provide concrete to the jobsite that has an air content of plus 2.0%, or minus 1.0%, of the AAC.

After the AAC has been established, it shall be verified and/or adjusted through daily checks of the air loss through the paver. The Contractor shall check the air loss through the paver a minimum of two times a day. A Revised AAC shall be required to be established by the Contractor if the average air loss from two consecutive tests deviates by more than 0.5% from the current accepted air loss. The testing operations performed by the Contractor to establish a revised AAC shall be performed to the satisfaction of the Engineer. The Contractor shall be solely responsible for any delays and/or costs that occur to the project while establishing revised AACs.

CONSTRUCTION METHODS

Aggregate Control

Gradation control – The supplier shall provide a detailed stockpile management plan, describing their process control procedure for shipping, handling, and stockpiling of each aggregate including workforce training.

**DETAILED SPECIFICATION
FOR
CONCRETE DURABILITY**

4 of 6

CONSTRUCTION METHODS

Aggregate Control

Gradation control – The supplier shall provide a detailed stockpile management plan, describing their process control procedure for shipping, handling, and stockpiling of each aggregate including workforce training.

Moisture control – All aggregate materials must be conditioned to a moisture content of not less than saturated surface dry (SSD) prior to batching. A watering process using an effective sprinkler system designed and operated by the Contractor shall be required on all coarse aggregate material stockpiles.

The Contractor shall provide verification that these processes have been performed by the supplier. The Engineer reserves the right to independently verify that the supplier has complied with these standards.

Mixing

Central mix plants - The total volume of the batch shall not exceed the designated size of the mixer or the rated capacity as shown on the manufacturer's rating plate.

Drum Mix Plants: After all solid materials are assembled in the mixer drum; the mixing time shall be a minimum of 60 seconds and a maximum of 5 minutes. The mixing time may be decreased if the ASTM C-94 11.3.3 mixer efficiency tests show that the concrete mixing is satisfactory. The Engineer may require an increase in the minimum mix time if the mixer efficiency test determines that the concrete is not being mixed satisfactorily. The minimum mixing time shall start after the mixer is fully charged. Mixers shall be operated at the speed recommended by the manufacturer as mixing speed. The mixer shall be charged so that a uniform blend of materials reached the mixer through out the charging cycle. Any additional slump water required shall be added to the mixing chamber by the end of the first 25% of the specified mixing time. Mixers shall not be used if the drum is not clean or if the mixing blades are damaged or badly worn

Ribbon mixers: After all solid materials are assembled in the mixer; the mixing time shall be a minimum of 30 seconds and a maximum of 2.5 minutes. The mixing time may be decreased if the ASTM C-94 11.3.3 mixer efficiency tests show that the concrete mixing is satisfactory. The Engineer may require an increase in the minimum mix time if the mixer efficiency test determines that the concrete is not being mixed satisfactorily. The minimum mixing time shall be indicated by an accurate timing device which is automatically started when the mixer is fully charged. Mixers shall be operated at the speed recommended by the manufacturer as mixing speed. The mixer shall be charged so that a uniform blend of materials reached the mixer through out the charging cycle. After any additional slump water is added to the mixing chamber the mixing shall continue for a minimum of 10 seconds. Mixers shall not be used if the mixer is not clean or if the mixing blades are damaged or badly worn.

**DETAILED SPECIFICATION
FOR
CONCRETE DURABILITY**

5 of 6

Truck Mixers -The capacities and mixing capabilities shall be as defined in ASTM C 94, and each unit shall have an attached plate containing the information described therein. The plate may be issued by the Truck Mixer Manufacturer. The mixer capacity shall not be exceeded, and the mixing speeds shall be within the designated limits. Truck mixers shall be equipped with a reliable reset revolution counter. If truck mixers are used for mixing while in transit, the revolution counter shall register the number of revolutions at mixing speed.

An authorized representative of the concrete producer shall certify that the interior of the mixer drum is clean and reasonably free of hardened concrete, that the fins or paddles are not broken or worn excessively, that the other parts are in proper working order, and that the unit has been checked by the representative within the previous 30 calendar day period to substantiate this certification. The current, signed certification shall be with the unit at all times.

The required mixing shall be between 70 and 90 revolutions. The mixing shall be at the rate designated by the manufacturer and shall produce uniform, thoroughly mixed concrete.

The Engineer may inspect mixer units at any time to assure compliance with certification requirements, and removal of inspection ports may be required. Should the Engineer question the quality of mixing, the Engineer may check the slump variation within the batch. Should the slump variation between two samples taken, one after approximately 20% discharge and one after approximately 90% discharge of the batch, show a variation greater than 3/4 inch (20 mm) or 25% of the average of the two, whichever is greater, the Engineer may require the mixing to be increased, the batch size reduced, the charging procedure be modified or the unit removed from the work.

The practice of adding water on the site shall be discouraged. After the slump of the concrete in the first round of trucks has been adjusted on-site, the amount of water added at the plant shall be adjusted accordingly for that day's work. All additions of water on site shall be approved by the Engineer.

CURING

Apply liquid curing compound in a fine atomized spray to form a continuous, uniform film on the horizontal surface, vertical edges, curbs and back of curbs immediately after the surface moisture has disappeared, but no later than 30 minutes after concrete placement. With approval of the Engineer, the timing of cure application may be adjusted due to varying weather conditions and concrete mix properties.

The cure system shall be on site and tested prior to concrete placement.

Apply a curing compound at a rate of application not less than 2 gallons per 25 square yards. The Contractor shall keep the material thoroughly mixed per the Manufacturer's recommendations. The curing compound shall not be diluted.

The finished product shall appear as a uniformly painted solid white surface. Areas exhibiting a blotchy or spotty appearance shall be recoated immediately.

**DETAILED SPECIFICATION
FOR
CONCRETE DURABILITY**

6 of 6

COMPLIANCE WITH STANDARDS

The Engineer will review and approve all material test reports and mix designs supplied by the Contractor before any placement of concrete. The Engineer will visually inspect the placed concrete and review the concrete test reports prior to final acceptance.

Acceptance sampling and testing will be performed using the sampling method and testing option selected by the Engineer. Acceptance testing will be performed at the frequency specified by the Engineer. Quality control measures to insure job control are the responsibility of the Contractor. The Engineer's testing and/or test results will not relieve the Contractor from his/her responsibilities to produce, deliver, and place concrete that meets all project requirements. The Engineer's test results are for acceptance purposes only.

If the results of the testing are not in compliance with the project specifications, the Engineer shall determine appropriate corrective action(s). Time extensions will not be granted to the Contractor during the time that the Engineer is determining the necessary corrective actions.

If, in the Engineer's judgment, the rejected material must be replaced, the material in question will be removed and replaced at the Contractor's sole expense. The removal costs will be deemed to include all relevant and associated costs including, but not limited to; re-mobilization, traffic control, re-grading the aggregate base course, if required, placement of material meeting the project specifications, and all other expenses. Time extensions will not be granted to the Contractor for any required repair work to meet the requirements of this specification.

If the Engineer decides that the material in question can remain in place, an adjustment to the contract unit price(s) may be made of up to 100% of the bid price(s) for the affected items of work.

MEASUREMENT AND PAYMENT

The cost associated with complying with the requirements as described herein, including any required remedial action(s), shall be included in the cost of other items of work and shall not be paid for separately.

Appendix 1
Revised Standard Details

NOTES:

1. ALL D.I.P. PIPE, FITTINGS, AND HYDRANT BARREL TO BE POLYWRAPPED PER AWWA C105.

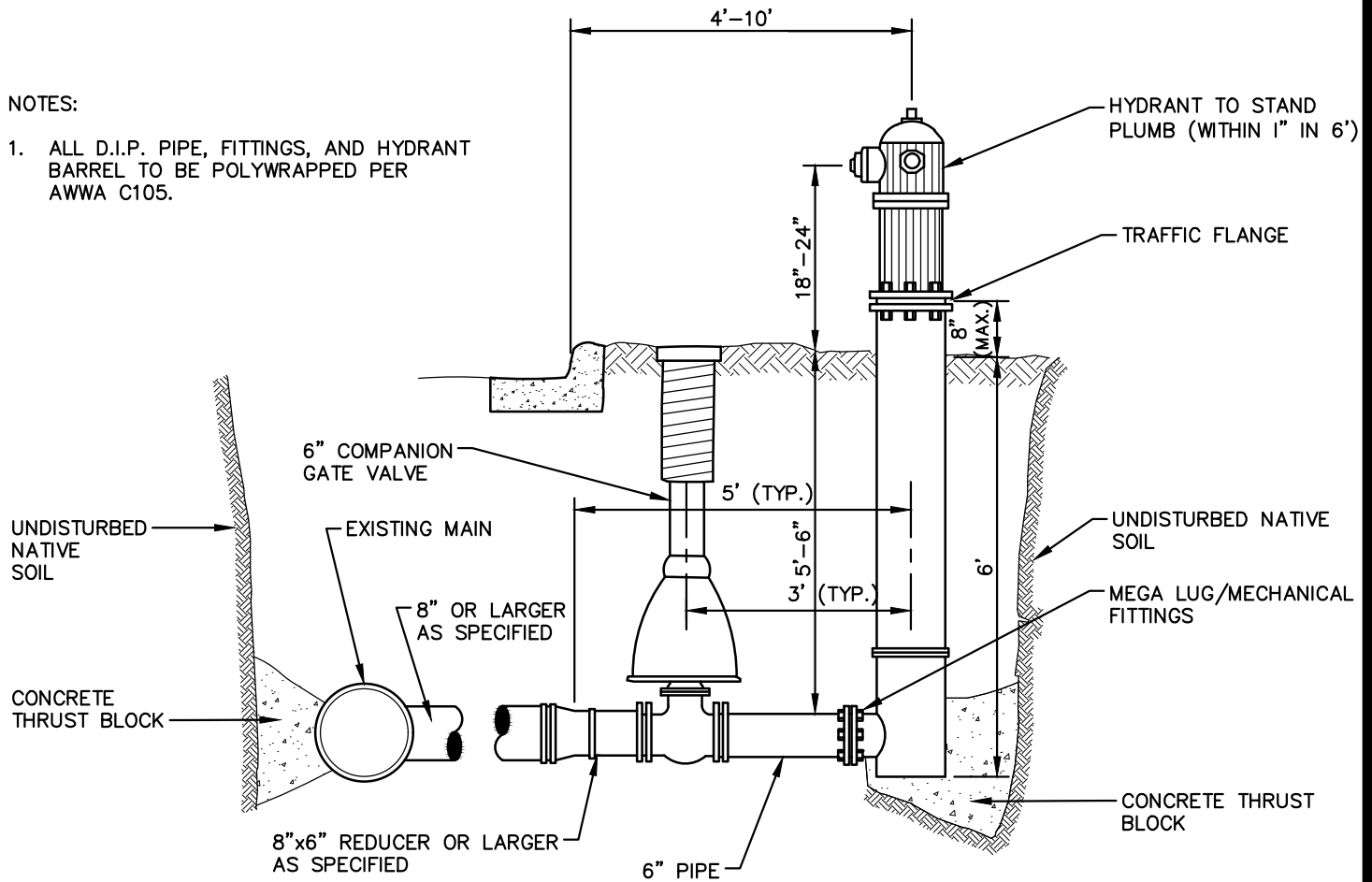

FIRE HYDRANT ASSEMBLY SD-W-1

REVISED
1-10-18



**CITY OF ANN ARBOR
PUBLIC SERVICES**
301 EAST HURON STREET
P.O. BOX 8647
ANN ARBOR, MI 48107-8647
734-794-6410
www.a2gov.org

REV. NO.	DATE	DRAWN BY	CHECKED BY
FIRE HYDRANT ASSEMBLY			
DR. DF	CH. CSS	DRAWING NO.	
SCALE N.T.S.	DATE 11/06/92	SD-W-1	

MINIMUM STANDARDS

THE MDOT GRADE PI OR P-NC CONCRETE AT THE FITTING FACE SHALL EXTEND TO WITHIN 2" OF THE BELL AND SHALL EXTEND FROM THE FITTING FACE A MINIMUM OF 2' TO THE UNDISTURBED SOLID GROUND.

THE DIMENSIONS OF THE THRUST BLOCK AT THE FACE OF THE UNDISTURBED SOLID GROUND SHALL BE AS SHOWN IN THE TABLE BELOW.

IF THERE ISN'T SUFFICIENT SPACE FOR THE INSTALLATION OF THE THRUST BLOCK WITHOUT INTERFERENCE WITH OTHER SERVICES, ANOTHER ARRANGEMENT SATISFACTORY TO THE ENGINEER SHALL BE USED.

FITTINGS I.D.	PLUG TEE CROSS		BENDS								HYDRANT	
			90°		45°		22½°		11¼°			
INCHES	W	H	W	H	W	H	W	H	W	H	W	H
4	1.0	1.0	1.0	1.0	1.0	1.0						
6	2.0	1.5	2.0	2.0	2.0	1.0	1.0	1.0	1.0	1.0	2.0	1.5
8	2.5	2.0	3.5	2.0	2.0	2.0	2.0	1.0	1.0	1.0	2.5	2.0
12	3.5	3.0	5.5	3.0	3.5	2.5	2.0	2.0	2.0	1.0		
16	6.0	3.5	6.0	4.0	5.0	3.0	3.5	2.5	2.0	2.0		

FOR FITTING SIZES LARGER THAN 16", THRUST BLOCK DIMENSIONS SHALL BE AS SPECIFIED BY ENGINEER.

W = WIDTH IN FEET
H = HEIGHT IN FEET

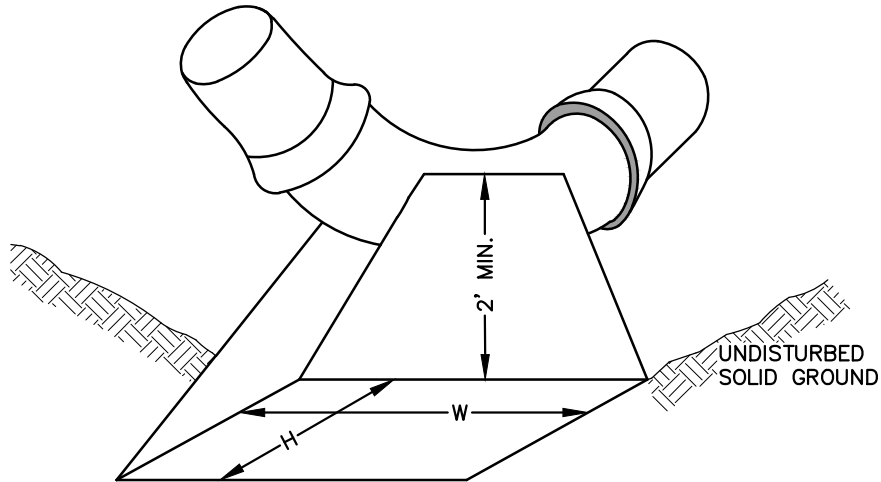

NOTE:

THESE ARE MINIMUM STANDARDS. WHERE SOIL CONDITIONS DICTATE, ADJUSTMENTS IN SIZE SHALL BE MADE AS DIRECTED BY THE PUBLIC SERVICES AREA ADMINISTRATOR.

REVISED
1-10-18

THRUST BLOCK SD-W-2



**CITY OF ANN ARBOR
PUBLIC SERVICES**
301 EAST HURON STREET
P.O. BOX 8647
ANN ARBOR, MI 48107-8647
734-794-6410
www.a2gov.org

REV. NO.	DATE	DRAWN BY	CHECKED BY
THRUST BLOCK			
DR. DF	CH. CSS	DRAWING NO.	
SCALE N.T.S.	DATE 11/06/92	SD-W-2	

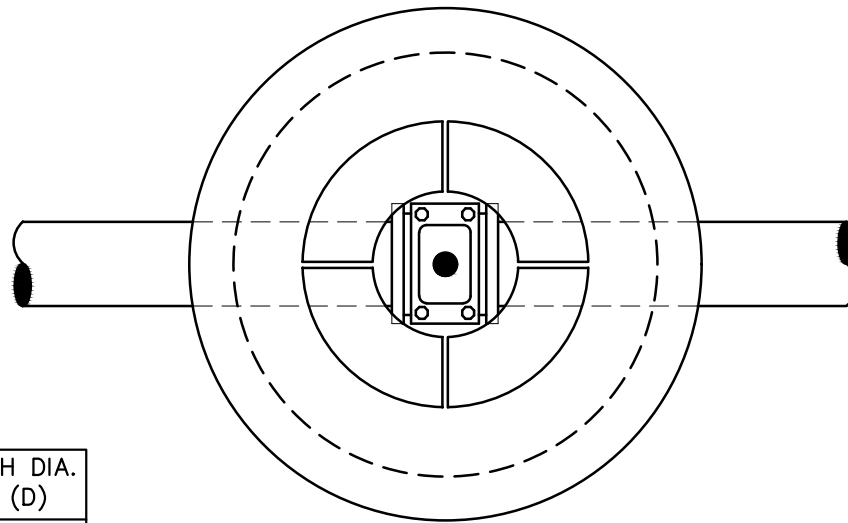

TOP VIEW

PIPE SIZE	MH DIA. (D)
12" OR LESS	5'
16"	6'

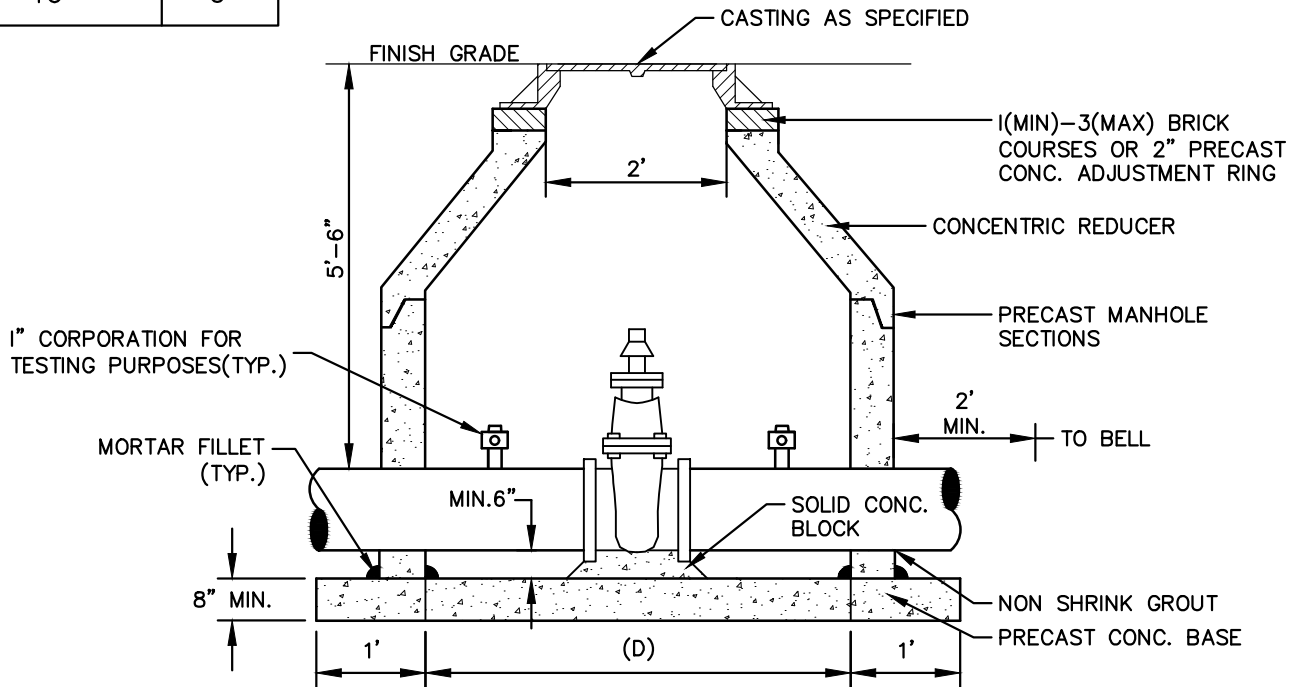

NOTES:

1. ALL LIFT HOLES AND JOINTS SHALL BE MORTARED BOTH INSIDE AND OUTSIDE
2. ALL JOINTS SHALL BE MADE WATER TIGHT WITH RUBBER GASKET JOINTS
3. NO STEPS ARE PERMITTED
4. MANHOLE SECTIONS SHALL MEET ASTM C-478

REVISED
1-10-18

GATE WELL FOR MAIN 16" & SMALLER SD-W-3



**CITY OF ANN ARBOR
PUBLIC SERVICES**
301 EAST HURON STREET
P.O. BOX 8647
ANN ARBOR, MI 48107-8647
734-794-6410
www.a2gov.org

REV. NO.	DATE	DRAWN BY	CHECKED BY
GATE WELL FOR MAIN 16" & SMALLER			
DR. DF	CH. CSS	DRAWING NO.	
SCALE N.T.S.	DATE 11/06/92	SD-W-3	

Appendix 2 Soil Borings



Materials
Testing
Consultants, INC.

**GEOTECHNICAL DATA REPORT
2017 STREET BORINGS BUNDLE NO. 1
Ann Arbor, Michigan**

Prepared For:

**CITY OF ANN ARBOR
Ann Arbor, Michigan**

Prepared By:

**MATERIALS TESTING CONSULTANTS, INC.
Ann Arbor, Michigan**

October 2017
MTC Project No. 171311



Materials
Testing
Consultants, INC.

MATERIALS Engineers, Independent TESTING Laboratories, Geotechnical & Environmental CONSULTANTS — Since 1968

693 Plymouth Ave. NE
Grand Rapids, MI 49505
(616) 456.5469

253 Dino Drive, Suite B
Ann Arbor, MI 48103
(734) 619.6868

(800) 968.8378 www.mtc-test.com

October 11, 2017
Project No. 171311

City of Ann Arbor
Project Management Services Unit
301 E. Huron Street
Ann Arbor, MI 48104

Attention: Anne Warrow, P.E.
Project Manager

Reference: Report of Geotechnical Investigation
2017 Street Borings Bundle No. 1
Ann Arbor, Michigan

Dear Ms. Warrow:

We have completed a geotechnical investigation for the above-referenced project. The purpose of this investigation has been to identify the general subsurface soil conditions at various streets within the City of Ann Arbor. This work has been performed as described in our proposal dated January 17, 2017.

Presented herein are descriptions of the geotechnical investigation and encountered conditions. The Appendix contains the report limitations and data collected during this investigation.

DESIGN CONSIDERATIONS

We have been provided the following documents and information for use in this investigation:

- A summary table of proposed soil borings and boring location maps initially provided by the City of Ann Arbor on August 3, 2017 and revised on August 23, 2017 detailing the quantity, depth, and location of the proposed borings.
- Email correspondence with Ms. Anne Warrow, P.E. of City of Ann Arbor regarding the project details and scope of work.

The areas of investigation are shown in Figure No.'s 1 to 4. The various sites are located in streets within the City of Ann Arbor. Construction is generally expected to range from repaving operations to full depth reconstruction. We understand that sanitary sewer improvements are planned on Stone School Road between Packard and Ticknor.

City of Ann Arbor
Project No. 171311
October 11, 2017
Page 2

INVESTIGATION METHODOLOGY

Solid stem auger and conventional hollow-stem auger methods with standard penetration test (SPT) along with field engineering reconnaissance were used to investigate the subsurface conditions. Boring locations are shown on Figure No.'s 1 through 4. Investigation procedures, soil classification information and boring logs are provided in the Appendix.

Number of Borings	45
Boring Depth Range, ft	5 to 20

Borings were drilled and other sampling was conducted solely to obtain indications of subsurface conditions as part of a geotechnical exploration program. No services were performed to evaluate subsurface environmental conditions.

Laboratory

Soil samples were reviewed by one of our engineers and technically classified according to the methods of ASTM D 2488 "Standard Practice for Description and Identification of Soils (Visual-Manual Procedure)". Calibrated penetrometer tests were performed on cohesive samples to obtain an indication of unconfined compressive strength values. Cohesive soil samples were subjected to moisture testing in accordance with ASTM D 2216 "Method for Laboratory Determination of Water (Moisture) Content of Soil, Rock, and Soil-Aggregate Mixtures"

A summary table of the soil conditions, laboratory results, and the estimated resilient modulus for each soil type is contained in the Appendix.

The estimated values for resilient modulus, M_r , have been provided based on the visual classification of the soil and Table 12-2 in the Michigan DOT User Guide for Mechanistic Empirical Pavement Design, Interim Edition dated March 2015. Other data including results from FWD testing, local knowledge, or from past ME pavement performance on similar subgrade materials may also be of use in estimating resilient modulus if they are available. Typically, recommendations based on visual classification are given as a range of values for various assumptions regarding compaction, moisture content and roadway type. Generally, more conservative values of resilient modulus should be used on high traffic roads with a higher cost to early failure, in areas of high soil moisture/high water table and in areas of variable soil, utility trenches, etc. Conversely, less conservative (higher range) values are typically used on lower traffic roads with drier and more uniform soils.

City of Ann Arbor
Project No. 171311
October 11, 2017
Page 3

INVESTIGATION RESULTS

Listed below are the existing site conditions at the time of our field work and the encountered subsurface conditions for each of the investigated sites. During our field investigation we observed and recorded the surface conditions of the asphalt pavements. The results of our condition survey are included below. The boring logs located in the Appendix should be reviewed for detailed soil descriptions. Some variation between boring locations may be expected.

Reported groundwater levels were taken at the time of drilling activities. Groundwater levels may fluctuate due to seasonal variations such as precipitation, snowmelt, nearby river or lake levels and other factors that may not be evident at the time of measurement. Groundwater levels may be different at the time of construction.

Frederick Drive between Green Road and Bardstown Trail

At the time of our investigation the pavement, in general, was in fair to poor condition with longitudinal cracking in the wheel paths developing into isolated alligator cracking in areas east of Greenbrier Boulevard and widespread alligator cracking and some potholes in areas west of Greenbrier Boulevard. Few small patches in fair to poor condition were observed. Cracks ranged from tight to open and were unsealed.

The existing pavement section consisted of 3 ½ to 5 inches of HMA over 6 to 7 inches of natural aggregate base material. Beneath the existing pavement section, subgrade soils generally consisted of stiff to hard *lean clay with sand* (CL) to the explored depth of 5 ft. In Boring B-3, stiff *sandy lean clay* (CL) was encountered to a depth of 1.7 ft and was underlain by *clayey sand* (SC) to the explored depth of 5 ft. Groundwater was not encountered in any of the borings.

MacGregor Lane between Larchmont Drive and Chatham Way

At the time of our investigation the pavement, in general, was in very poor condition with widespread alligator cracking and some potholes. Cracks ranged from tight to open and were unsealed.

The existing pavement section consisted of 3 ¼ to 4 inches of HMA over 7 to 16 inches of natural aggregate base material. Beneath the existing pavement section, subgrade soils generally consisted of hard *sandy lean clay* (CL) to the explored depth of 5 ft or *clayey sand* (SC) to 3 ft underlain by very stiff *sandy lean clay* (CL) to the explored depth of 5 ft. Groundwater was not encountered in any of the borings.

City of Ann Arbor
Project No. 171311
October 11, 2017
Page 4

Prestwick Court between MacGregor Lane and Dead End

At the time of our investigation the pavement, in general, was in poor condition with widespread alligator cracking and few potholes. Cracks ranged from tight to open and were unsealed.

The existing pavement section consisted of 3 ¼ inches of HMA over 6 to 7 inches of natural aggregate base material. Beneath the existing pavement section, subgrade soils generally consisted of very stiff *sandy lean clay* (CL) or *clayey sand* (SC) to the explored depth of 5 ft. Groundwater was not encountered in any of the borings.

Sulgrave Place between Barrister Drive and Dead End

At the time of our investigation the pavement, in general, was in very poor condition with severe block cracking, widespread areas of alligator cracking and few potholes. Large to small patches in fair to poor condition were observed throughout. Cracks ranged from tight to open and were unsealed.

The existing pavement section consisted of 3 to 4 ¼ inches of HMA over 4 inches of crushed asphalt base material. Beneath the existing pavement section, subgrade soils generally consisted of very stiff to hard *lean clay with sand* (CL) to the explored depth of 5 ft or *clayey sand* (SC) to 3.5 ft underlain by very stiff *sandy lean clay* (CL) to the explored depth of 5 ft. Groundwater was not encountered in any of the borings.

Kipling Drive between Earhart Road and Fairmount Drive

At the time of our investigation the pavement, in general, was in poor to very poor condition with moderate to severe block cracking, widespread areas of alligator cracking and some potholes. Most of the severe distress was observed east of Natalie Lane. Many small patches in fair to poor condition were observed east of Natalie Lane. Cracks ranged from tight to open and were generally unsealed.

The existing pavement section consisted of 3 inches of HMA over 8 to 18 inches of natural aggregate base material. Beneath the existing pavement section, subgrade soils generally consisted of *poorly graded sand* (SP) or *poorly graded sand with silt* (SP-SM) to depths ranging from 3 ft to 4 ft and stiff to very stiff *lean clay* (CL) to the explored depth of 5 ft. Groundwater was encountered at a depth of 2.0 ft in Boring B-11.

City of Ann Arbor
Project No. 171311
October 11, 2017
Page 5

Wynnstone Drive between South Folkstone Court and Dead End

At the time of our investigation the pavement, in general, was in poor condition with severe block cracking, widespread areas of alligator cracking and occasional potholes. Cracks ranged from tight to open and were generally unsealed.

The existing pavement section consisted of 2 ¾ to 4 inches of HMA over 6 to 10 inches of natural aggregate base material. Beneath the existing pavement section, subgrade soils generally consisted of very stiff to hard *sandy lean clay* (CL) or *poorly graded sand with silt* (SP-SM) to the explored depth of 5 ft. Groundwater was not encountered in any of the borings.

Severn Court between Wynnstone Drive and Dead End

At the time of our investigation the pavement, in general, was in poor condition with widespread areas of alligator cracking, occasional potholes and distortion near manholes. Few small patches in fair to poor condition were observed. Cracks ranged from tight to open and were generally unsealed.

The existing pavement section consisted of 3 to 4 ½ inches of HMA over 6 to 8 inches of natural aggregate base material. Beneath the existing pavement section, subgrade soils within Boring B-16 consisted of *poorly graded sand with silt* (SP-SM) to 2.5 ft and very stiff *sandy lean clay* (CL) to the explored depth of 5 ft. Subgrade soils within Boring B-17 consisted of hard *sandy lean clay* (CL) to 2.2 ft and *clayey sand* (SC) to the explored depth of 5 ft. Groundwater was not encountered in any of the borings.

Fairmount Drive between Kipling Drive and Dead End

At the time of our investigation the pavement, in general, was in poor condition with moderate to severe block cracking and widespread areas of alligator cracking. Pothole patches in poor condition were observed near Boring B-18. Relatively new patches in very good condition were observed near the pedestrian ramps at the Windemere Drive intersection. Cracks ranged from tight to open and were generally unsealed.

The existing pavement section consisted of 3 to 4 inches of HMA over 8 to 12 inches of natural aggregate base material. Beneath the existing pavement section, subgrade soils generally consisted of very stiff to hard *sandy lean clay* (CL) or *lean clay with sand* (CL) to the explored depth of 5 ft. Subgrade soils within Boring B-19 consisted of *poorly graded sand with silt* (SP-SM) to the explored depth of 5 ft. Groundwater was not encountered in any of the borings.

City of Ann Arbor
Project No. 171311
October 11, 2017
Page 6

Windemere Court between Windemere Drive and Dead End

At the time of our investigation the pavement, in general, was in poor condition with widespread areas of alligator cracking and few large potholes. Few small patches in fair condition were observed. Cracks ranged from tight to open and were unsealed.

The existing pavement section consisted of 2 ¼ inches of HMA over 7 inches of natural aggregate base material. Beneath the existing pavement section, subgrade soils consisted of very stiff to hard *lean clay with sand* (CL) to the explored depth of 5 ft. Groundwater was not encountered in the boring.

Windemere Drive between Windemere Court and Dead End

At the time of our investigation the pavement, in general, was in poor to very poor condition with moderate to severe block cracking and widespread areas of alligator cracking. Severe alligator cracking was observed east of Fairmount Drive. Pothole patches in fair condition were observed throughout, with most of the patches in the southern lane west of Bardstown Trail (near Borings B-23 and B-24). A large patch in good condition was observed between Charter Place and Markbarry Drive near Boring B-26. Cracks ranged from tight to open and were generally unsealed.

The existing pavement section consisted of 3 ¼ to 5 ¼ inches of HMA over 8 to 10 inches of natural aggregate base material. Beneath the existing pavement section, subgrade soils generally consisted of very stiff to hard *lean clay with sand* (CL) to the explored depth of 5 ft. Subgrade soils within Boring B-25 consisted of *clayey sand* (SC) to 1.8 ft underlain by hard *lean clay* (CL) to 3.5 ft and *clayey sand* (SC) to the explored depth of 5 ft. Subgrade soils within Boring B-27 consisted of *poorly graded sand with silt* (SP-SM) to the explored depth of 5 ft. Groundwater was not encountered in any of the borings.

Sturbridge Court between Bardstown Trail and Dead End

At the time of our investigation the pavement, in general, was in poor condition with widespread areas of alligator cracking, particularly in the cul-de-sac. Cracks ranged from tight to open and were occasionally sealed.

The existing pavement section consisted of 3 ¾ inches of HMA over 6 to 7 inches of natural aggregate base material. Beneath the existing pavement section, subgrade soils generally consisted of very stiff to hard *lean clay* (CL) or *lean clay with sand* (CL) to the explored depth of 5 ft. Groundwater was not encountered in any of the borings.

City of Ann Arbor
Project No. 171311
October 11, 2017
Page 7

Stanton Court between Green Road and Dead End

At the time of our investigation the pavement, in general, was in fair to poor condition with moderate to severe block cracking throughout and alligator cracking within the southern lane. Cracks ranged from tight to open and were generally unsealed. Relatively new patches in very good condition were observed near the pedestrian ramps at the Green Road intersection.

The existing pavement section consisted of 2 ½ to 3 ¾ inches of HMA over 12 to 16 inches of natural aggregate base material. Beneath the existing pavement section, subgrade soils within Boring B-31 consisted of very stiff *lean clay with sand* (CL) to the explored depth of 5 ft. Subgrade soils within Boring B-32 consisted of *poorly graded sand with silt* (SP-SM) to the explored depth of 5 ft. Groundwater was not encountered in any of the borings.

West Dobson Place between Wolverhampton Lane and Dead End

At the time of our investigation the pavement, in general, was in poor condition with severe block cracking throughout and some areas of alligator cracking. Slight rutting was observed within the wheel paths. Cracks ranged from tight to open and were unsealed.

The existing pavement section consisted of 2 ½ to 3 inches of HMA over 6 to 8 inches of natural aggregate base material. Beneath the existing pavement section, subgrade soils generally consisted of *poorly graded sand* (SP) to depths ranging from 1.6 to 1.8 ft underlain by very stiff to hard *lean clay with sand* (CL) or *sandy lean clay* (CL) to the explored depth of 5 ft. Groundwater was not encountered in any of the borings.

Wolverhampton Lane between Glazier Way and Dead End

At the time of our investigation the pavement, in general, was in fair to poor condition with moderate to severe block cracking throughout and some alligator cracking south of Dobson Place and within the cul-de-sac. Slight rutting was observed within the wheel paths. Cracks ranged from tight to open and were unsealed.

The existing pavement section consisted of 2 ½ to 3 ¼ inches of HMA over 6 inches of natural aggregate base material. Beneath the existing pavement section, subgrade soils generally consisted of *poorly graded sand* (SP) to depths ranging from 1.7 to 2.5 ft underlain by very stiff *sandy lean clay* (CL) or *clayey sand* (SC) to the explored depth of 5 ft. Subgrade soils within Boring B-35 consisted of *poorly graded sand with silt* (SP-SM) to the explored depth of 5 ft. Groundwater was not encountered in any of the borings.

City of Ann Arbor
Project No. 171311
October 11, 2017
Page 8

Stone School Road between Packard Street and Eisenhower Parkway

At the time of our investigation the pavement, in general, was in fair to poor condition with initial to moderate block cracking throughout with cracks frequently deteriorating into alligator cracking or potholes. Slight rutting was observed within the wheel paths. Some small patches in fair to poor condition were observed. Areas of greatest distress were generally in the center lanes and near the Ticknor Court and Eisenhower Parkway intersections. Cracks ranged from tight to open and were generally unsealed.

The existing pavement section consisted of 8 to 10 inches of HMA over 18 to 24 inches of natural aggregate base material. Beneath the existing pavement section, subgrade soils within Boring B-39 consisted of loose *poorly graded sand with silt* (SP-SM) to 3.7 ft underlain by very loose to medium dense *poorly graded sand* (SP) to the explored depth of 20 ft. Subgrade soils within Boring B-40 consisted of *silty sand* (SM) to the explored depth of 5 ft. Groundwater was not encountered in any of the borings.

Stone School Road between Eisenhower Parkway and I-94

At the time of our investigation the pavement, in general, was in poor condition with moderate to severe block cracking throughout with cracks frequently deteriorating into alligator cracking or potholes. Slight rutting was observed within the wheel paths. Frequent small patches in fair to poor condition were observed. Cracks ranged from tight to open and were generally unsealed.

The existing pavement section consisted of 3 ¾ to 5 ¼ inches of HMA over 7 to 8 inches of natural aggregate base material. Beneath the existing pavement section, subgrade soils generally consisted of *poorly graded sand with silt* (SP-SM) to 2.0 ft underlain by very stiff *sandy lean clay* (CL) to the explored depth of 5 ft or *poorly graded sand with silt* (SP-SM) to the explored depth of 5 ft. Groundwater was not encountered in any of the borings.

Greene Street between Hill Street and East Keeche Avenue/Kipke Drive

At the time of our investigation the pavement, in general, was in poor condition with widespread areas of alligator cracking and some potholes. Frequent pothole patches were observed and were generally in fair to poor condition. Occasional larger patches were observed and were generally in good to fair condition. Cracks ranged from tight to open and were generally unsealed.

The existing pavement section consisted of 4 ½ to 4 ¾ inches of HMA over 8 inches of natural aggregate base material or 10 inches of crushed limestone base material. Beneath the existing pavement section, subgrade soils generally consisted of *poorly graded sand with clay* (SP-SC) or *poorly graded sand with silt* (SP-SM) to the explored depth of 5 ft. Groundwater was not encountered in any of the borings.

City of Ann Arbor
Project No. 171311
October 11, 2017
Page 9

CLOSURE

In this report, descriptions of the geotechnical investigation and encountered conditions have been presented. The limitations of this study are described in the Appendix. The borings presented in this report are based upon a limited number of subsurface samples obtained from various sampling locations. The samples may not fully indicate the nature and extent of the variations that actually exist between sampling locations. For that reason, among others, we strongly recommend that we be retained to observe earthwork construction. If variations or other latent conditions become evident during construction, we would be able to review these conditions and provide recommendations as appropriate.

We appreciate the opportunity to provide this service to you on this project. Should you have any questions or require further assistance, please contact our office.

Sincerely,

MATERIALS TESTING CONSULTANTS, INC.



Robert J. Warren, P.E.
Assistant Project Engineer



Daniel S. Elliott, P.E.
SE Michigan Branch Manager

Attachments: Figure No.'s 1 to 4 – Boring Location Plans
Table 1 – Summary of Investigation Results
Appendix
- Limitations
- Boring Log Terminology
- Soil Classification Chart
- Boring Logs

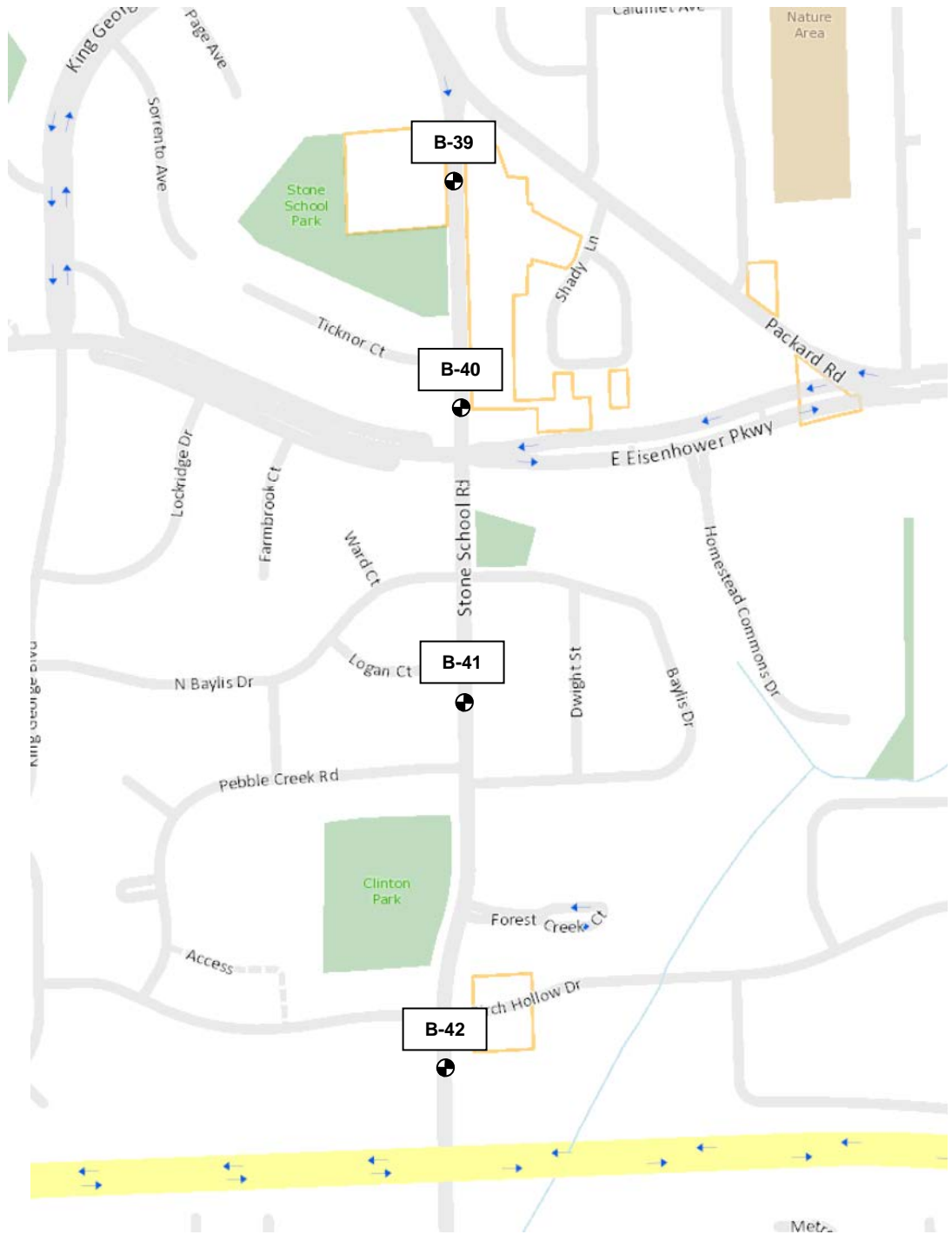

LEGEND

⊕ SOIL BORING (TYP)

NOTE: STREET PLAN FROM WASHTENAW COUNTY GIS



TITLE: LOCATION PLAN			PROJECT: ANN ARBOR STREET BORINGS BUNDLE #1
SCALE: NTS	DATE: 8/31/17	PROJECT NO.: 171311	Materials Testing Consultants, INC. 253 DINO DR., SUITE B, ANN ARBOR, MICH. 48103 • PHONE 800-968-8378
FIG. NO.: 3	DR. BY: RW	REV. BY: DE	

Table 1 - Summary of Investigation Results, Continued

Street Name	Limits	Borings	Asphalt Thickness	Base Thickness and Description	Subgrade Soils	Estimated Resilient Modulus, psi	Laboratory Results - Moisture, %
Windemere Dr	Windemere Ct to Dead End	B-23 to B-28	3 1/4" to 5 1/4"	8" to 10" natural aggregate	B-23, B-24, B-26, B-28: Lean clay with sand (CL) to 5ft B-25: Clayey sand (SC) to 1.8ft, lean clay (CL) to 3.5ft and clayey sand (SC) to 5ft B-27: Poorly graded sand with silt (SP-SM) to 5ft	SP-SM: 5,900 - 8,100 CL: 3,700 - 5,100 SC: 3,700 - 5,100	CL: 12 - 17 SC: 12 - 14
Sturbridge Ct	Bardstown Trl to Dead End	B-29, B-30	3 3/4"	6" to 7" of natural aggregate	B-29, B-30: Lean clay (CL) or lean clay with sand (CL) to 5ft	CL: 3,700 - 5,100	CL: 12 - 20
Stanton Ct	Green Rd to Dead End	B-31, B-32	2 1/2" to 3 3/4"	12" to 16" of natural aggregate	B-31: Lean clay with sand (CL) to 5ft B-32: Poorly graded sand with silt (SP-SM) to 5ft	SP-SM: 5,900 - 8,100 CL: 3,700 - 5,100	CL: 12 - 17
W Dobson Pl	Wolverhampton Ln to Dead End	B-33, B-34	2 1/2" to 3"	6" to 8" of natural aggregate	B-33, B-34: Poorly graded sand (SP) to 1.6ft-1.8ft and lean clay with sand (CL) or sandy lean clay (CL) to 5ft	SP: 5,500 - 7,500 CL: 3,700 - 5,100	CL: 12 - 35
Wolverhampton Ln	Glazier Way to Dead End	B-35 to B-38	2 1/2" to 3 1/4"	6" natural aggregate	B-35: Poorly graded sand with silt (SP-SM) to 5ft B-36, B-37, B-38: Poorly graded sand (SP) to 1.7ft-2.5ft and sandy lean clay (CL) or clayey sand (SC) to 5ft	SP: 5,500 - 7,500 SP-SM: 5,900 - 8,100 CL: 3,700 - 5,100 SC: 3,700 - 5,100	CL: 15 SC: 8 - 9
Stone School Rd	Packard to Eisenhower	B-39, B-40	8" to 10"	18" to 24" of natural aggregate	B-39: Poorly graded sand with silt (SP-SM) to 3.7ft and poorly graded sand (SP) to 20ft B-40: Silty sand (SM) to 5ft	SP-SM: 5,900 - 8,100 SP: 5,500 - 7,500 SM: 4,400 - 6,000	-
Stone School Rd	Eisenhower to I-94	B-41, B-42	3 3/4" to 5 1/4"	7" to 8" of natural aggregate	B-41: Poorly graded sand with silt (SP-SM) to 2.0ft and sandy lean clay (CL) to 5ft B-42: Poorly graded sand with silt (SP-SM) to 5ft	SP-SM: 5,900 - 8,100 CL: 3,700 - 5,100	CL: 16
Greene St	Hill St to E Keeche Ave / Kipke Dr	B-43 to B-45	4 1/2" to 4 3/4"	8" of natural aggregate or 10" of crushed limestone	B-43, B-44, B-45: Poorly graded sand with clay (SP-SC), poorly graded sand with silt (SP-SM) or poorly graded sand with silt and gravel (SP-SM) to 5ft	SP-SM: 5,900 - 8,100 SP-SC: 3,700 - 5,100	-

APPENDIX

- **Limitations**
- **Boring Log Terminology**
- **Soil Classification Chart**
- **Boring Logs**

LIMITATIONS

Soil Variations

The recommendations in this report are based upon the data obtained from the soil borings. This report does not reflect variations which may occur between these borings, and which would not become evident until construction. If variations then become evident, it would be necessary for a re-evaluation of recommendations of this report, after performing on-site observations.

Warranties

We have prepared this report in accordance with generally accepted soil and foundation engineering practices. We make no other warranties, either expressed or implied, as to the professional advice provided under the terms of our agreement and included in this report. This report is prepared exclusively for our client and may not be relied upon by other parties without written consent from our office.

Boring Logs

In the process of obtaining and testing samples and preparing this report, we follow reasonable and accepted practice in the field of soil engineering. Field logs maintained during drilling describe field occurrences, sampling locations, and other information. The samples obtained in the field are subjected to additional testing in the laboratory and differences may exist between the field logs and the final logs. The engineer reviews the field logs and laboratory test data, and then prepares the final boring logs. Our recommendations are based on the contents of the final logs.

Review of Design Plans and Specifications

In the event that any changes in the design of the building or the location, however slight, are planned, our recommendations shall not be considered valid unless modified or approved in writing by our office. We recommend that we be provided the opportunity to review the final design and specifications in order to determine whether changes in the original concept may have affected the validity of our recommendations, and whether our recommendations have, in fact, been implemented in the design and specifications.

Boring Log Terminology

Soil Classification Systems:

- ASTM D2487 Standard Classification of Soils for Engineering Purposes (Unified Soil Classification System)
- ASTM D2488 Standard Practice for Description and Identifications of Soils (Visual-Manual Procedure)

Minor Component Quantifying Terms:

Trace (less than 5%); Few (5 to 10%); Little (15 to 25%); Some (30 to 45%); Mostly (50 to 100%)

Sample Types and Numbering:

- | | | | |
|-----------|--------------------------------------|----------|--------------------------------|
| S | SPT, split-barrel sample, ASTM D1586 | U | Shelby tube sample, ASTM D1587 |
| *S | Other than 2" split barrel sample | A | Auger cuttings |
| L | SPT with liner, ASTM D1586 | R | Rock core run |
| | | G | Geoprobe liner |

Grain Size:

Boulder	>12"
Cobble	12" to 3"
Coarse Gravel	3" to 0.75"
Fine Gravel	0.75" to No. 4
Coarse Sand	No. 4 to No. 10
Medium Sand	No. 10 to No. 40
Fine Sand	No. 40 to No. 200

Clay - Soil passing a No. 200 sieve that can be made to exhibit plasticity (putty-like properties) and exhibits considerable strength when air dry (ASTM D2487).

Silt - Soil passing a No. 200 sieve that is nonplastic or very slightly plastic and exhibits little or no strength when air dry (ASTM D2487).

Peat - A soil composed of decomposed vegetable tissue with organic odor, dark brown to black color, spongy consistency, and a fibrous to amorphous texture.

"Grades with" or "Grades without" may be used to describe soil when characteristics vary within a stratum.

Moisture Condition: Dry (absence of visible moist.); Moist (damp but no visible water); Wet (visible free water)

Compactness (Coarse Grained Soils) and Consistency (Fine Grained Soils):

N-value	Relative Density	Compactness	N-value	Approx. Shear Strength, ksf	Consistency
0 - 4	0 - 20%	Very Loose	0 - 2	0.25	Very Soft
5 - 10	20 - 40%	Loose	3 - 4	0.25 - 0.5	Soft
11 - 30	40 - 70%	Med. Dense	5 - 8	0.5 - 1	Med. Stiff
31 - 50	70 - 90%	Dense	9 - 16	1 - 2	Stiff
>50	90 - 100%	Very Dense	17 - 32	2 - 4	Very Stiff
			>32	>4	Hard

Groundwater Observations:

During - indicates water level encountered during the boring

End - indicates water level immediately after drilling

Date and Depth - Measurements at indicated date

Water observations in pervious soils are considered reliable for the date. Water observations in impervious soils may not be accurate groundwater measurements unless records are made over several days time. Groundwater levels will fluctuate for both pervious and impervious soils.

ASTM D2488 Soil Classification Outline - Coarse Grained Soil:

Primary Soil Type	Group Name and (Group Symbol)	Criteria	
GRAVEL	Well-graded GRAVEL (GW) Poorly-graded GRAVEL (GP)	<5% fines, <15% sand	
	Well-graded GRAVEL with sand (GW) Poorly-graded GRAVEL with sand (GP)	<5% fines, >15% sand	
	Well-graded GRAVEL with silt (GW-GM) Poorly-graded GRAVEL with silt (GP-GM) Well-graded GRAVEL with clay (GW-GC) Poorly-graded GRAVEL with clay (GP-GC)	10% fines, <15% sand	
	Well-graded GRAVEL with silt and sand (GW-GM) Poorly-graded GRAVEL with silt and sand (GP-GM) Well-graded GRAVEL with clay and sand (GW-GC) Poorly-graded GRAVEL with clay and sand (GP-GC)	10% fines, >15% sand	
	Silty GRAVEL (GM) Clayey GRAVEL (GC)	>15% fines, <15% sand	
	Silty GRAVEL with sand (GM) Clayey GRAVEL with sand (GC)	>15% fines, >15% sand	
	SAND	Well-graded SAND (SW) Poorly-graded SAND (SP)	<5% fines, <15% gravel
		Well-graded SAND with gravel (SW) Poorly-graded SAND with gravel (SP)	<5% fines, >15% gravel
		Well-graded SAND with silt (SW-SM) Poorly-graded SAND with silt (SP-SM) Well-graded SAND with clay (SW-SC) Poorly-graded SAND with clay (SP-SC)	10% fines, <15% gravel
		Well-graded SAND with silt and gravel (SW-SM) Poorly-graded SAND with silt and gravel (SP-SM) Well-graded SAND with clay and gravel (SW-SC) Poorly-graded SAND with clay and gravel (SP-SC)	10% fines, >15% gravel
Silty SAND (SM) Clayey SAND (SC)		>15% fines, <15% gravel	
Silty SAND with gravel Clayey SAND with gravel		>15% fines, >15% gravel	

ASTM D2488 Soil Classification Outline - Fine Grained Soil:

Primary Soil Type	Group Name and (Group Symbol)	Criteria	
SILT	SILT (ML) Elastic SILT (MH)	<15% plus No. 200	
	SILT with sand (ML) Elastic SILT with sand (MH)	15-25% plus No. 200, % sand > % gravel	
	SILT with gravel (ML) Elastic SILT with gravel (MH)	15-25% plus No. 200, % gravel > % sand	
	Sandy SILT (ML) Sandy Elastic SILT (MH)	>30% plus No. 200, % sand > % gravel, <15% gravel	
	Sandy SILT with gravel (ML) Sandy Elastic SILT with gravel (MH)	>30% plus No. 200, % sand > % gravel, >15% gravel	
	Gravelly SILT (ML) Gravelly Elastic SILT (MH)	>30% plus No. 200, % gravel > % sand, <15% sand	
	Gravelly SILT with sand (ML) Gravelly Elastic SILT with sand (MH)	>30% plus No. 200, % gravel > % sand, >15% sand	
	CLAY	Lean CLAY (CL) Fat CLAY (CH)	<15% plus No. 200
		Lean CLAY with sand (CL) Fat CLAY with sand (CH)	15-25% plus No. 200, % sand > % gravel
Lean CLAY with gravel (CL) Fat CLAY with gravel (CH)		15-25% plus No. 200, % gravel > % sand	
Sandy lean CLAY (CL) Sandy fat CLAY (CH)		>30% plus No. 200, % sand > % gravel, <15% gravel	
Sandy lean CLAY with gravel (CL) Sandy fat CLAY with gravel (CH)		>30% plus No. 200, % sand > % gravel, >15% gravel	
Gravelly lean CLAY (CL) Gravelly fat CLAY (CH)		>30% plus No. 200, % gravel > % sand, <15% sand	
Gravelly lean CLAY with sand (CL) Gravelly fat CLAY with sand (CL)		>30% plus No. 200, % gravel > % sand, >15% sand	

Note: Percentages are based on estimated amounts of fines, sand and gravel to the nearest 5%

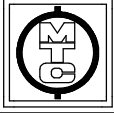

**LOG
OF
BORING**

Project: City of Ann Arbor 2017 Street Borings Bundle No.1

Client: City of Ann Arbor

Location: Ann Arbor, Michigan

Drill Type: CME 55

Crew Chief: JC Field Eng.: RW Rev. By: RW

Coordinates:

Elevation: Datum:

Notes: Stone School Road; Located 90°N of 2862 Stone School Driveway Centerline and 14'E of West Curb

Plugging Record: Backfilled borehole with compacted cuttings, patched pavement with cold patch. Cave in at 10.8 ft.

Date Begin: 09/05/17

Date End: 09/05/17

Tooling	Type	Dia.	Groundwater, ft.	
Casing	HSA	4 1/2"	During	None
Sampler	SPT	2"	End	NA
Core			Seepage	
Tube			Date	Depth, ft.
SPT Hammer	Auto			

Depth Drilled: 20.0 ft.

Component Percentages: Trace < 5%, Few 5-10%, Little 15-25%, Some 30-45%, Mostly 50-100%

QP = Calibrated Penetrometer (tons/sq. ft.)

Elev. FT.	Depth FT.	Sample Number	Recov. FT.	Penetration (Blows Per 6") ASTM D 1586	*USCS Group Symbol	*DESCRIPTION	QP tsf	MST %	DD pcf	REMARKS
	1					8" HMA; 18" Natural Aggregate Base				
	2	S-1	1.5	6-10-8 N=18			2.2			
	3	S-2	1.5	4-4-4 N=8	SP-SM	Brown poorly graded SAND with silt; mostly coarse to fine sand, few silty fines, moist	3.7			
	4	S-3	1.5	3-4-3 N=7		Brown poorly graded SAND; mostly coarse to fine sand, moist				
	5									
	6									
	7	S-4	0.3	2-2-1 N=3						S-4 and S-5: Poor recovery; possible coarse gravel / COBBLE
	8									
	9									
	10	S-5	1.0	2-2-1 N=3						
	11									
	12				SP					
	13									
	14									
	15	S-6	1.5	4-6-7 N=13		Grades with trace coarse to fine gravel				
	16									
	17									
	18									
	19									
	20	S-7	1.5	7-8-9 N=17			20.0			
						End of Boring				

* Visual estimate following ASTM D 2488 unless laboratory testing has been performed. Stratification changes are approximated between samples.

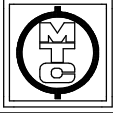

**LOG
OF
BORING**

Project No.: 171311

Boring No.: B-40

Sheet: 1 of 1

Project: City of Ann Arbor 2017 Street Borings Bundle No.1

Client: City of Ann Arbor

Location: Ann Arbor, Michigan

Drill Type: CME 55

Crew Chief: JC **Field Eng.:** RW **Rev. By:** RW

Coordinates:

Elevation: **Datum:**

Notes: Stone School Road; Located 80'N of 3015 Stone School Driveway Centerline and 25'E of West Curb

Plugging Record: Backfilled borehole with compacted cuttings, patched pavement with cold patch.

Date Begin: 09/05/17

Date End: 09/05/17

Tooling	Type	Dia.	Groundwater, ft.	
Casing			During	None
Sampler	SSA	3 1/2"	End	NA
Core			Seepage	
Tube			Date	Depth, ft.
SPT Hammer				

Depth Drilled: 5.0 ft.

Component Percentages: Trace < 5%, Few 5-10%, Little 15-25%, Some 30-45%, Mostly 50-100%

QP = Calibrated Penetrometer (tons/sq. ft.)

Elev. FT.	Depth FT.	Sample Number	Recov. FT.	Dyn. Cone Eq. "N": ASTM STP 399	*USCS Group Symbol	*DESCRIPTION	QP tsf	MST %	DD pcf	REMARKS
	0.5					10" HMA; 24" Natural Aggregate Base				
	1.0									
	1.5	A-1	0.3							
	2.0									
	2.5									
	3.0	A-2	0.3			Brown silty SAND; mostly fine sand, little silty fines, moist	2.8			
	3.5									
	4.0				SM					
	4.5									
	5.0	A-3	0.3				5.0			
						End of Boring				

* Visual estimate following ASTM D 2488 unless laboratory testing has been performed. Stratification changes are approximated between samples.



Materials
Testing
Consultants, INC.

**GEOTECHNICAL DATA REPORT
2017 STREET BORINGS BUNDLE NO. 2
ANN ARBOR, MICHIGAN**

Prepared For:

**CITY OF ANN ARBOR
Ann Arbor, Michigan**

Prepared By:

**MATERIALS TESTING CONSULTANTS, INC.
Ann Arbor, Michigan**

January 2018
MTC Project No. 171311.1



Materials
Testing
Consultants, INC.

MATERIALS Engineers, Independent TESTING Laboratories, Geotechnical & Environmental CONSULTANTS — Since 1968

693 Plymouth Ave. NE
Grand Rapids, MI 49505
(616) 456.5469

253 Dino Drive, Suite B
Ann Arbor, MI 48103
(734) 619.6868

(800) 968.8378 www.mtc-test.com

January 17, 2018
Project No. 171311.1

City of Ann Arbor
Project Management Services Unit
301 E. Huron Street
Ann Arbor, MI 48104

Attention: Anne Warrow, P.E.
Project Manager

Reference: Report of Geotechnical Investigation
2017 Street Borings Bundle No. 2
Ann Arbor, Michigan

Dear Ms. Warrow:

We have completed a geotechnical investigation for the above-referenced project. The purpose of this investigation has been to identify the general subsurface soil conditions at various streets within the City of Ann Arbor. This work has been performed as described in our proposal dated January 17, 2017.

Presented herein are descriptions of the geotechnical investigation and encountered conditions. The Appendix contains the report limitations and data collected during this investigation.

AVAILABLE INFORMATION

We have been provided the following documents and information for use in this investigation:

- A summary table of proposed soil borings and boring location map provided by the City of Ann Arbor on November 8, 2017 detailing the quantity, depth, and location of the proposed borings.
- Email and telephone correspondence with Mr. David Dykman, P.E. of the City of Ann Arbor regarding the project details and scope of work, including one additional boring on State Street that was not included in the summary table.

The areas of investigation are shown in Figure No.'s 1 to 3. The various sites are located in streets within the City of Ann Arbor. Construction is generally expected to range from repaving operations to full depth reconstruction. In-situ infiltration testing may be performed at a later date.

City of Ann Arbor
Project No. 171311.1
January 17, 2018
Page 2

INVESTIGATION METHODOLOGY

Conventional hollow-stem auger methods with standard penetration test (SPT) along with field engineering reconnaissance were used to investigate the subsurface conditions. Boring locations are shown on Figure No.'s 1 through 3. Investigation procedures, soil classification information and boring logs are provided in the Appendix.

Number of Borings	6
Boring Depths, ft	20

Borings were drilled and other sampling was conducted solely to obtain indications of subsurface conditions as part of a geotechnical exploration program. No services were performed to evaluate subsurface environmental conditions.

Laboratory

Soil samples were reviewed by one of our engineers and technically classified according to the methods of ASTM D 2488 "Standard Practice for Description and Identification of Soils (Visual-Manual Procedure)". Calibrated penetrometer tests were performed on cohesive samples to obtain an indication of unconfined compressive strength values. Cohesive soil samples were subjected to moisture testing in accordance with ASTM D 2216 "Method for Laboratory Determination of Water (Moisture) Content of Soil, Rock, and Soil-Aggregate Mixtures"

A summary table of the soil conditions, laboratory results, and the estimated resilient modulus for each soil type is contained in the Appendix.

The estimated values for resilient modulus, M_r , have been provided based on the visual classification of the soil and Table 12-2 in the Michigan DOT User Guide for Mechanistic Empirical Pavement Design, Interim Edition dated March 2015. Other data including results from FWD testing, local knowledge, or from past ME pavement performance on similar subgrade materials may also be of use in estimating resilient modulus if they are available. Typically, recommendations based on visual classification are given as a range of values for various assumptions regarding compaction, moisture content and roadway type. Generally, more conservative values of resilient modulus should be used on high traffic roads with a higher cost to early failure, in areas of high soil moisture/high water table and in areas of variable soil, utility trenches, etc. Conversely, less conservative (higher range) values are typically used on lower traffic roads with drier and more uniform soils.

INVESTIGATION RESULTS

Listed below are the existing site conditions at the time of our field work and the encountered subsurface conditions for each of the investigated sites. During our field investigation we observed and recorded the surface conditions of the asphalt pavements. The results of our condition survey are included below. The boring logs located in the Appendix should be reviewed for detailed soil descriptions. Some variation between boring locations may be expected.

Groundwater level readings were taken at the time of drilling activities. Groundwater levels may fluctuate due to seasonal variations such as precipitation, snowmelt, nearby river or lake levels and other factors that may not be evident at the time of measurement. Groundwater levels may be different at the time of construction.

Greene Street between Hill Street and East Keeche Avenue/Kipke Drive

At the time of our investigation the pavement, in general, was in poor condition with widespread areas of alligator cracking and some potholes. Frequent pothole patches were observed and were generally in fair to poor condition. Occasional larger patches were observed and were generally in good to fair condition. Cracks ranged from tight to open and were generally unsealed.

The existing pavement section consisted of 4 $\frac{3}{4}$ to 5 $\frac{3}{4}$ inches of HMA over 6 inches of natural aggregate base material or 8 inches of crushed limestone base material. Boring B-46 was performed outside of the roadway due to utility conflicts and encountered 12 inches of clayey topsoil at surface. Beneath the surficial material, subgrade soils generally consisted of *poorly graded sand with silt* (SP-SM) or *silty sand* (SM) to the explored depth of 20 ft. Boring B-46 encountered *sandy silt* (ML) from 12 to 17 ft, and Boring B-47 encountered *sandy lean clay* (CL) from 17 to 20 ft. Groundwater was encountered in the borings at depths ranging from 13.5 to 14.0 ft.

South State Street between Packard Street and East Hoover Avenue

At the time of our investigation the pavement, in general, was in fair to poor condition with moderate block cracking and initial crack spreading and erosion throughout. Near the Packard and Hoover intersections, the pavement was generally in poor condition with severe rutting, alligator cracking and patches in poor condition. Cracks ranged from tight to open and were unsealed.

The existing pavement section consisted of 4 to 4 $\frac{1}{4}$ inches of HMA over 12 to 13 inches of concrete. Beneath the existing pavement section, subgrade soils in Boring B-49 consisted of *silty sand* (SM) to 5 ft underlain by *poorly graded sand with silt* (SP-SM) to 19.5 ft and *poorly graded sand* (SP) to the explored depth of 20 ft. Subgrade soils in Boring B-50 consisted of *clayey sand*

City of Ann Arbor
Project No. 171311.1
January 17, 2018
Page 4

(SC) to 2.8 ft underlain by *sandy lean clay* (CL) to 14 ft and *poorly graded sand with clay* (SP-SC) to the explored depth of 20 ft. Groundwater was encountered in the borings at depths ranging from 13.5 to 17.0 ft.

Hikone Road Parking Lot between Packard Road and Dead End

At the time of our investigation the parking lot pavement, in general, was in very good condition with few defects. The pavement on Hikone Road, in general, was in good condition with transverse cracks that were widely spaced and generally tight.

The existing pavement section in the parking lot consisted of 3 ¼ inches of HMA over 7 inches of crushed limestone base material. Beneath the existing pavement section, subgrade soils consisted of *silty sand* (SM) to 3.8 ft underlain by *sandy lean clay* (CL) to 5.5 ft, *poorly graded sand with silt* (SP-SM) to 8 ft and *sandy lean clay* (CL) or *lean clay* (CL) to the explored depth of 20 ft. Groundwater was encountered at a depth of 3.8 ft.

CLOSURE

In this report, descriptions of the geotechnical investigation and encountered conditions have been presented. The limitations of this study are described in the Appendix. The borings presented in this report are based upon a limited number of subsurface samples obtained from various sampling locations. The samples may not fully indicate the nature and extent of the variations that actually exist between sampling locations. For that reason, among others, we strongly recommend that we be retained to observe earthwork construction. If variations or other latent conditions become evident during construction, we would be able to review these conditions and provide recommendations as appropriate.

City of Ann Arbor
Project No. 171311.1
January 17, 2018
Page 5

We appreciate the opportunity to provide this service to you on this project. Should you have any questions or require further assistance, please contact our office.

Sincerely,

MATERIALS TESTING CONSULTANTS, INC.



Robert J. Warren, P.E.
Assistant Project Engineer



Daniel S. Elliott, P.E.
SE Michigan Branch Manager

Attachments: Figure No.'s 1 to 3 – Boring Location Plans
Table 1 – Summary of Investigation Results
Appendix
- Limitations
- Boring Log Terminology
- Soil Classification Chart
- Boring Logs

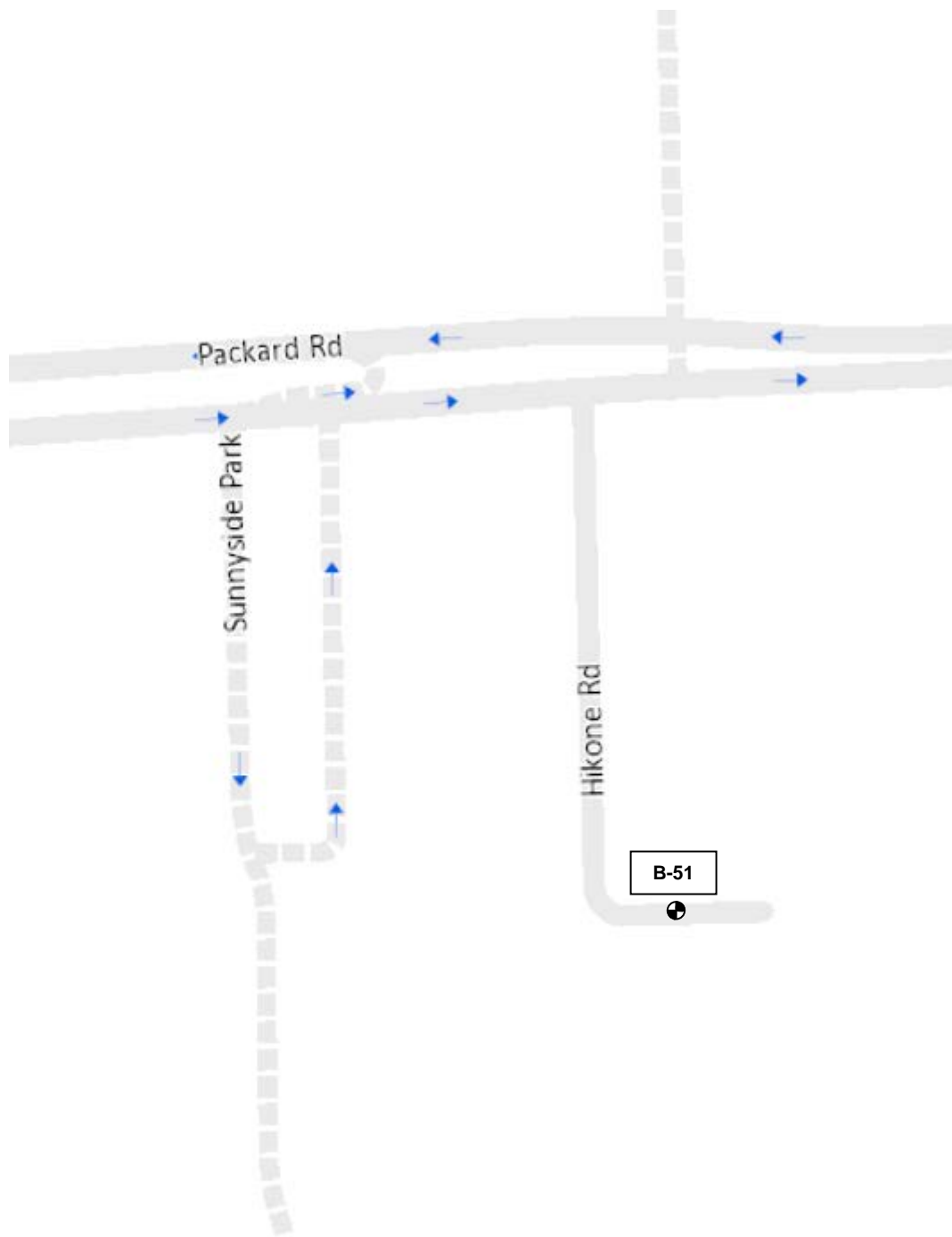

LEGEND

⊕ SOIL BORING (TYP)

NOTE: STREET PLAN FROM WASHTENAW COUNTY GIS



TITLE: LOCATION PLAN			PROJECT: ANN ARBOR STREET BORINGS BUNDLE #2
SCALE: NTS	DATE: 12/20/17	PROJECT NO.: 171311.1	Materials Testing Consultants, INC. 253 DINO DR., SUITE B, ANN ARBOR, MICH. 48103 • PHONE 800-968-8378
FIG. NO.: 3	DR. BY: RW	REV. BY: DE	

Table 1 - Summary of Investigation Results

Street Name	Limits	Borings	Asphalt Thickness	Base Thickness and Description	Subgrade Soils	Estimated Resilient Modulus, psi	Laboratory Results - Moisture, %
Greene St	Hill St to E Keeche Ave / Kipke Dr	B-46 to B-48	4 3/4" to 5 3/4"	6" of natural aggregate or 8" of crushed limestone	B-46: Poorly graded sand with silt (SP-SM) to 12ft, sandy silt (ML) to 17ft and poorly graded sand with silt (SP-SM) to 20ft B-47: Silty sand (SM) to 2ft, poorly graded sand with silt (SP-SM) to 17ft and sandy lean clay (CL) to 20ft B-48: Silty sand (SM) to 5.5ft and poorly graded sand with silt (SP-SM) to 20ft	SP-SM: 5,900 - 8,100 ML: 3,700 - 5,100 SM: 4,400 - 6,000 CL: 3,700 - 5,100	CL: 21
S. State St	Packard St to E Hoover Ave	B-49, B-50	4" to 4 1/4"	12" to 13" of concrete	B-49: Silty sand (SM) to 5ft, poorly graded sand with silt (SP-SM) to 19.5ft and poorly graded sand (SP) to 20ft B-50: Clayey sand (SC) to 2.8ft, sandy lean clay (CL) to 14ft and poorly graded sand with clay (SP-SC) to 20ft	SM: 4,400 - 6,000 SP-SM: 5,900 - 8,100 SP: 5,500 - 7,500 SC: 3,700 - 5,100 CL: 3,700 - 5,100 SP-SC: 3,700 - 5,100	SC: 13 CL: 17 - 26
Hikone Rd (Parking Lot)	Packard Rd to Dead End	B-51	3 1/4"	7" of crushed limestone	B-51: Silty sand (SM) to 3.8ft, sandy lean clay (CL) to 5.5ft, poorly graded sand with silt (SP-SM) to 8ft and sandy lean clay (CL) or lean clay (CL) to 20ft	SM: 4,400 - 6,000 CL: 3,700 - 5,100 SP-SM: 5,900 - 8,100	CL: 15 - 18

APPENDIX

- **Limitations**
- **Boring Log Terminology**
- **Soil Classification Chart**
- **Boring Logs**

LIMITATIONS

Soil Variations

The recommendations in this report are based upon the data obtained from the soil borings. This report does not reflect variations which may occur between these borings, and which would not become evident until construction. If variations then become evident, it would be necessary for a re-evaluation of recommendations of this report, after performing on-site observations.

Warranties

We have prepared this report in accordance with generally accepted soil and foundation engineering practices. We make no other warranties, either expressed or implied, as to the professional advice provided under the terms of our agreement and included in this report. This report is prepared exclusively for our client and may not be relied upon by other parties without written consent from our office.

Boring Logs

In the process of obtaining and testing samples and preparing this report, we follow reasonable and accepted practice in the field of soil engineering. Field logs maintained during drilling describe field occurrences, sampling locations, and other information. The samples obtained in the field are subjected to additional testing in the laboratory and differences may exist between the field logs and the final logs. The engineer reviews the field logs and laboratory test data, and then prepares the final boring logs. Our recommendations are based on the contents of the final logs.

Review of Design Plans and Specifications

In the event that any changes in the design of the building or the location, however slight, are planned, our recommendations shall not be considered valid unless modified or approved in writing by our office. We recommend that we be provided the opportunity to review the final design and specifications in order to determine whether changes in the original concept may have affected the validity of our recommendations, and whether our recommendations have, in fact, been implemented in the design and specifications.

Boring Log Terminology

Soil Classification Systems:

- ASTM D2487 Standard Classification of Soils for Engineering Purposes (Unified Soil Classification System)
- ASTM D2488 Standard Practice for Description and Identifications of Soils (Visual-Manual Procedure)

Minor Component Quantifying Terms:

Trace (less than 5%); Few (5 to 10%); Little (15 to 25%); Some (30 to 45%); Mostly (50 to 100%)

Sample Types and Numbering:

- | | | | |
|-----------|--------------------------------------|----------|--------------------------------|
| S | SPT, split-barrel sample, ASTM D1586 | U | Shelby tube sample, ASTM D1587 |
| *S | Other than 2" split barrel sample | A | Auger cuttings |
| L | SPT with liner, ASTM D1586 | R | Rock core run |
| | | G | Geoprobe liner |

Grain Size:

Boulder	>12"
Cobble	12" to 3"
Coarse Gravel	3" to 0.75"
Fine Gravel	0.75" to No. 4
Coarse Sand	No. 4 to No. 10
Medium Sand	No. 10 to No. 40
Fine Sand	No. 40 to No. 200

Clay - Soil passing a No. 200 sieve that can be made to exhibit plasticity (putty-like properties) and exhibits considerable strength when air dry (ASTM D2487).

Silt - Soil passing a No. 200 sieve that is nonplastic or very slightly plastic and exhibits little or no strength when air dry (ASTM D2487).

Peat - A soil composed of decomposed vegetable tissue with organic odor, dark brown to black color, spongy consistency, and a fibrous to amorphous texture.

"Grades with" or "Grades without" may be used to describe soil when characteristics vary within a stratum.

Moisture Condition: Dry (absence of visible moist.); Moist (damp but no visible water); Wet (visible free water)

Compactness (Coarse Grained Soils) and Consistency (Fine Grained Soils):

N-value	Relative Density	Compactness	N-value	Approx. Shear Strength, ksf	Consistency
0 - 4	0 - 20%	Very Loose	0 - 2	0.25	Very Soft
5 - 10	20 - 40%	Loose	3 - 4	0.25 - 0.5	Soft
11 - 30	40 - 70%	Med. Dense	5 - 8	0.5 - 1	Med. Stiff
31 - 50	70 - 90%	Dense	9 - 16	1 - 2	Stiff
>50	90 - 100%	Very Dense	17 - 32	2 - 4	Very Stiff
			>32	>4	Hard

Groundwater Observations:

During - indicates water level encountered during the boring

End - indicates water level immediately after drilling

Date and Depth - Measurements at indicated date

Water observations in pervious soils are considered reliable for the date. Water observations in impervious soils may not be accurate groundwater measurements unless records are made over several days time. Groundwater levels will fluctuate for both pervious and impervious soils.

ASTM D2488 Soil Classification Chart - Coarse Grained Soil:

Primary Soil Type	Group Name and (Group Symbol)	Criteria	
GRAVEL	Well-graded GRAVEL (GW) Poorly graded GRAVEL (GP)	<5% fines, <15% sand	
	Well-graded GRAVEL with sand (GW) Poorly-graded GRAVEL with sand (GP)	<5% fines, >15% sand	
	Well-graded GRAVEL with silt (GW-GM) Poorly graded GRAVEL with silt (GP-GM) Well-graded GRAVEL with clay (GW-GC) Poorly-graded GRAVEL with clay (GP-GC)	10% fines, <15% sand	
	Well-graded GRAVEL with silt and sand (GW-GM) Poorly graded GRAVEL with silt and sand (GP-GM) Well-graded GRAVEL with clay and sand (GW-GC) Poorly graded GRAVEL with clay and sand (GP-GC)	10% fines, >15% sand	
	Silty GRAVEL (GM) Clayey GRAVEL (GC)	>15% fines, <15% sand	
	Silty GRAVEL with sand (GM) Clayey GRAVEL with sand (GC)	>15% fines, >15% sand	
	SAND	Well-graded SAND (SW) Poorly-graded SAND (SP)	<5% fines, <15% gravel
		Well-graded SAND with gravel (SW) Poorly-graded SAND with gravel (SP)	<5% fines, >15% gravel
		Well-graded SAND with silt (SW-SM) Poorly-graded SAND with silt (SP-SM) Well-graded SAND with clay (SW-SC) Poorly-graded SAND with clay (SP-SC)	10% fines, <15% gravel
		Well-graded SAND with silt and gravel (SW-SM) Poorly-graded SAND with silt and gravel (SP-SM) Well-graded SAND with clay and gravel (SW-SC) Poorly-graded SAND with clay and gravel (SP-SC)	10% fines, >15% gravel
		Silty SAND (SM) Clayey SAND (SC)	>15% fines, <15% gravel
		Silty SAND with gravel Clayey SAND with gravel	>15% fines, >15% gravel

ASTM D2488 Soil Classification Outline - Fine Grained Soil:

Primary Soil Type	Group Name and (Group Symbol)	Criteria	
SILT	SILT (ML) Elastic SILT (MH)	<15% plus No. 200	
	SILT with sand (ML) Elastic SILT with sand (MH)	15-25% plus No. 200, % sand > % gravel	
	SILT with gravel (ML) Elastic SILT with gravel (MH)	15-25% plus No. 200, % gravel >% sand	
	Sandy SILT (ML) Sandy Elastic SILT (MH)	>30% plus No. 200, % sand > % gravel, <15% gravel	
	Sandy SILT with gravel (ML) Sandy Elastic SILT with gravel (MH)	>30% plus No. 200, % sand > % gravel, >15% gravel	
	Gravelly SILT (ML) Gravelly Elastic SILT (MH)	>30% plus No. 200, % gravel > % sand, <15% sand	
	Gravelly SILT with sand (ML) Gravelly Elastic SILT with sand (MH)	>30% plus No. 200, % gravel > % sand, >15% sand	
	CLAY	Lean CLAY (CL) Fat CLAY (CH)	<15% plus No. 200
		Lean CLAY with sand (CL) Fat CLAY with sand (CH)	15-25% plus No. 200, % sand > % gravel
		Lean CLAY with gravel (CL) Fat CLAY with gravel (CH)	15-25% plus No. 200, % gravel >% sand
Sandy lean CLAY (CL) Sandy fat CLAY (CH)		>30% plus No. 200, % sand > % gravel, <15% gravel	
Sandy lean CLAY with gravel (CL) Sandy fat CLAY with gravel (CH)		>30% plus No. 200, % sand > % gravel, >15% gravel	
Gravelly lean CLAY (CL) Gravelly fat CLAY (CH)		>30% plus No. 200, % gravel > % sand, <15% sand	
Gravelly lean CLAY with sand (CL) Gravelly fat CLAY with sand (CL)		>30% plus No. 200, % gravel > % sand, >15% sand	

Note: Percentages are based on estimated amounts of fines, sand and gravel to the nearest 5%

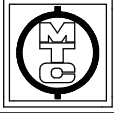

Project: City of Ann Arbor 2017 Street Borings Bundle No. 2

Client: City of Ann Arbor, MI

Location: Ann Arbor, MI

Drill Type: CME 45

Crew Chief: ZM Field Eng.: RW Rev. By: RW

Coordinates:

Elevation: Datum:

Notes: Hikone Parking Lot; Located 12'S, 52'E of NW Corner of Parking Lot

Plugging Record: Backfilled borehole with compacted cuttings, patched pavement with cold patch. Cave in at 3.8 ft.

Date Begin: 12/20/17

Date End: 12/20/17

Tooling	Type	Dia.	Groundwater, ft.	
Casing	HSA	3 1/2"	During	3.8
Sampler	SPT	2"	End	NA
Core			Seepage	
Tube			Date	Depth, ft.
SPT Hammer	Auto			

Depth Drilled: 20.0 ft.

Component Percentages: Trace < 5%, Few 5-10%, Little 15-25%, Some 30-45%, Mostly 50-100%

QP = Calibrated Penetrometer (tons/sq. ft.)

Elev. FT.	Depth FT.	Sample Number	Recov. FT.	Penetration (Blows Per 6") ASTM D 1586	*USCS Group Symbol	*DESCRIPTION	QP tsf	MST %	DD pcf	REMARKS
	1					3 1/4" HMA, 7" Crushed Limestone Aggregate Base	0.9			
	2	S-1	0.5	10-10-5 N=15	SM	Brown silty SAND; mostly coarse to fine sand, little silty fines, few coarse to fine gravel, moist				S-1, S-3 to S-6: Poor recovery; possible coarse gravel/COBBLE S-3: Wet sand encountered at 3.8'
	3	S-2	1.5	7-7-6 N=13						
	4	S-3	0.5	5-6-4 N=10	CL	Gray sandy lean CLAY; mostly clayey fines, some coarse to fine sand, moist	3.8			
	5						5.5			
	6									
	7	S-4	0.8	6-9-9 N=18	SP-SM	Brown poorly graded SAND with silt; mostly medium to fine sand, few silty fines, trace fine gravel, wet	8.0			
	8									
	9									
	10	S-5	1.3	3-3-4 N=7	CL	Gray sandy lean CLAY; mostly clayey fines, some coarse to fine sand, trace coarse to fine gravel, moist	2.5	18		S-5: Occasional seams of wet coarse to fine sand
	11									
	12									
	13									
	14									
	15	S-6	1.2	2-3-5 N=8	CL	Gray lean CLAY; mostly clayey fines, moist	12.0	2.75	18	
	16									
	17									
	18									
	19									
	20	S-7	1.5	4-6-8 N=14			2.5	17		
							20.0			

End of Boring

* Visual estimate following ASTM D 2488 unless laboratory testing has been performed. Stratification changes are approximated between samples.

Memo

To: Ms. Anne Warrow – City of Ann Arbor
 From: Katherine C. Hennicken, P.E. – TTL Associates, Inc.
 Date: February 5, 2018
 Re: Geotechnical Bundle #1

TTL has completed the soil borings and pavement cores associated with Geotechnical Bundle #1 in Ann Arbor, Michigan. This memo provides a brief description the encountered pavement, as well as crushed stone thicknesses.

Sixty soil borings, some of which contained associated pavement cores, were performed by TTL during the period from October 4, 2017 through January 26, 2018. Seven soil borings and associated pavement cores were cancelled via email on December 1, 2017. The soil borings are designated SB and the pavement cores are designated PC. The soil borings and pavement core locations were located in the field by the City of Ann Arbor.

The encountered pavement thicknesses are summarized in the tables below.

Location	Limits		Soil Boring Number	Pavement Thickness		Subgrade AASHTO Lab Class	Recommended Resilient Modulus (psi)
				Asphalt (inches)	Crushed Stone (inches)		
Riverview Dr Dover Place	Geddes	Huntington	SB-1	4	9	A-4 (5)	8,050
			SB-2	4	9		
			SB-3	-	7		
			SB-4	2½	12½		
			SB-5	5½	8½		
			SB-6	3	7		
			SB-7	3	9		
S. Seventh Street	Stadium	Scio Church	PC-8	6½	-	A-4 (5)	8,050
			PC-9	6	-		
			PC-10	5½	-		
			PC-11	5½	-		
			PC-12	5	-		
			PC-13	5¼	-		
			PC-14	6¼	-		
			PC-15	5	-		
			PC-16	7	-		
			PC-17	6½	-		
			PC-18	6	-		
			PC-19	6¼	-		
			PC-20	6	-		
			PC-21	6	6		

Location	Limits		Soil Boring Number	Pavement Thickness		Subgrade AASHTO Lab Class	Recommended Resilient Modulus (psi)
				Asphalt (inches)	Crushed Stone (inches)		
South State Street	Packard St	E Hoover Ave	SB-22 through SB-28	**Cancelled by City of Ann Arbor**			
South State Street	Stimson	W. Oakbrook					
South Industrial Highway	Stimson	E. Eisenhower Parkway	SB-29A	2½	9½		8,050
			SB-29B	2½	11½		
			SB-30A	8½	6		
			SB-30B	9	11		
			SB-31A	8	18		
			SB-31B	8¼	11¾	A-4 (2)	
			SB-32	9	12		
			SB-33	8	13		
			SB-34	9	15		
Sheridan Drive	Washtenaw	Londonderry	SB-35	3	12		8,050
			SB-36	2	8		
			SB-37	2	12	A-6 (10)	
			SB-38	3	-		
			SB-39	4	-		

Location	Limits		Soil Boring Number	Pavement Thickness		Subgrade AASHTO Lab Class	Recommended Resilient Modulus (psi)
				Asphalt (inches)	Concrete (inches)		
Jackson Ave	Wagner Rd	City or MDOT Jurisdiction	SB-40	-	10		8,050
			SB-41	6	7		
			SB-42	5½	13½		
			SB-43	3	9		
			SB-44	3	10		
			SB-45	-	9		
			SB-46	3	8		
			SB-47	-	8		
			SB-48	4	2		
			SB-49	12	-		
			SB-50	4	13	A-4 (7)	
			SB-51	11	-		

Location	Limits		Soil Boring Number	Pavement Thickness		Subgrade AASHTO Lab Class	Recommended Resilient Modulus (psi)
				Asphalt (inches)	Crushed Stone (inches)		
Horman Ct	Olivia Ave	S Forest Ave	SB-52	5 ½	-	A-1 (0)	12,550
S Forest Ave	Minerva Rd	Roosevelt Ave	SB-53	13	-	A-3 (0)	12,550
Brookwood	White St	Packard St	SB-54	4	4	A-3 (0)	12,550
Sycamore	White St	Pack Place	SB-55	6	-	A-4 (0)	8,050
Rock Creek	Huntington	Dead End	SB-56	3	11	A-4 (4)	8,050
			SB-56-1	2	11		
Lafayette Rd	Highland Rd	Awixa / Highland	SB-57	6	-	A-4 (7)	8,050
			SB-58	3	-		

Photographs of three representative pavement cores from each of South Seventh Street and South Industrial Highway are attached to this report.

Please let us know if you have any questions or comments at this time.

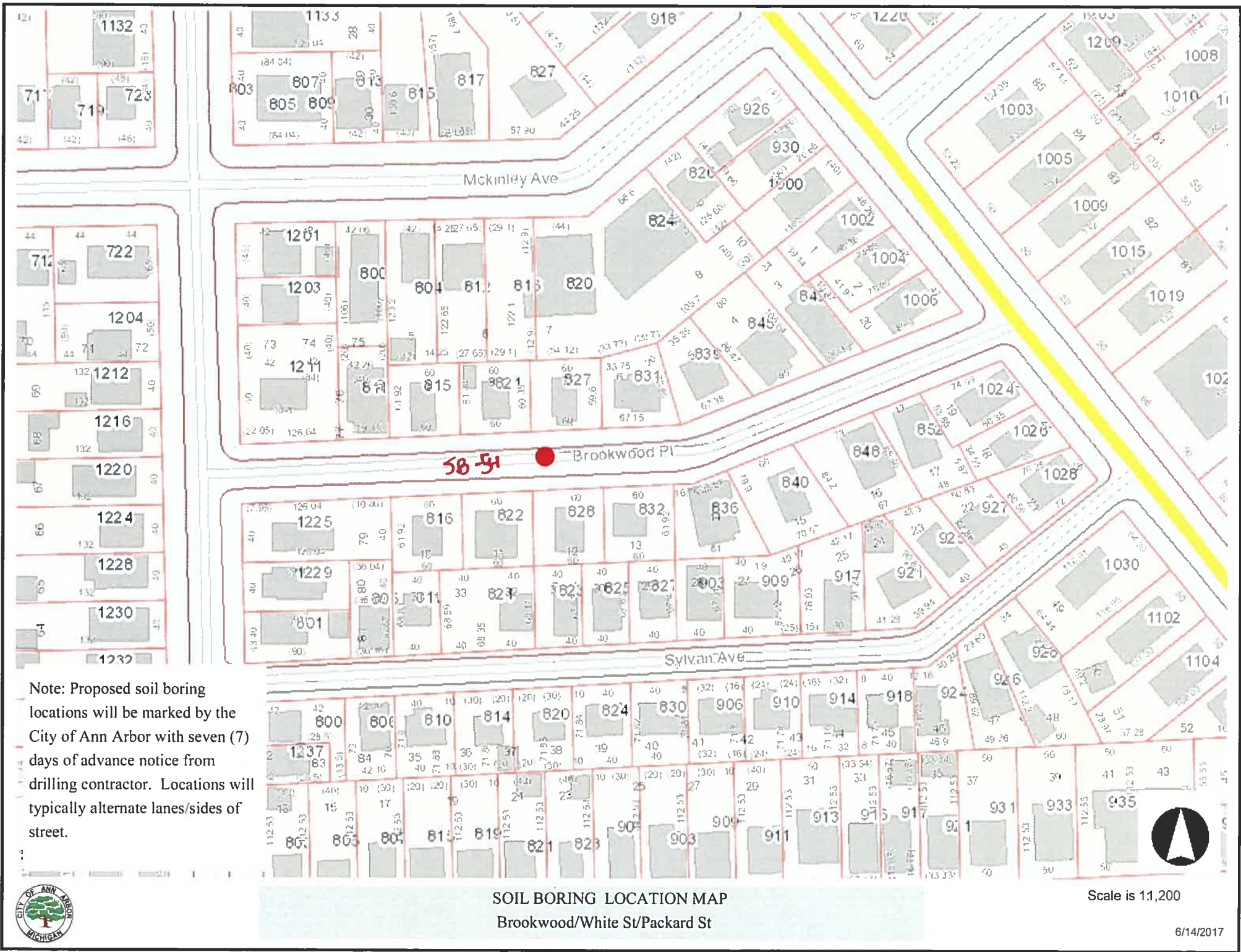

Note: Proposed soil boring locations will be marked by the City of Ann Arbor with seven (7) days of advance notice from drilling contractor. Locations will typically alternate lanes/sides of street.

SOIL BORING LOCATION MAP
 Brookwood/White St/Packard St

Scale is 11,200

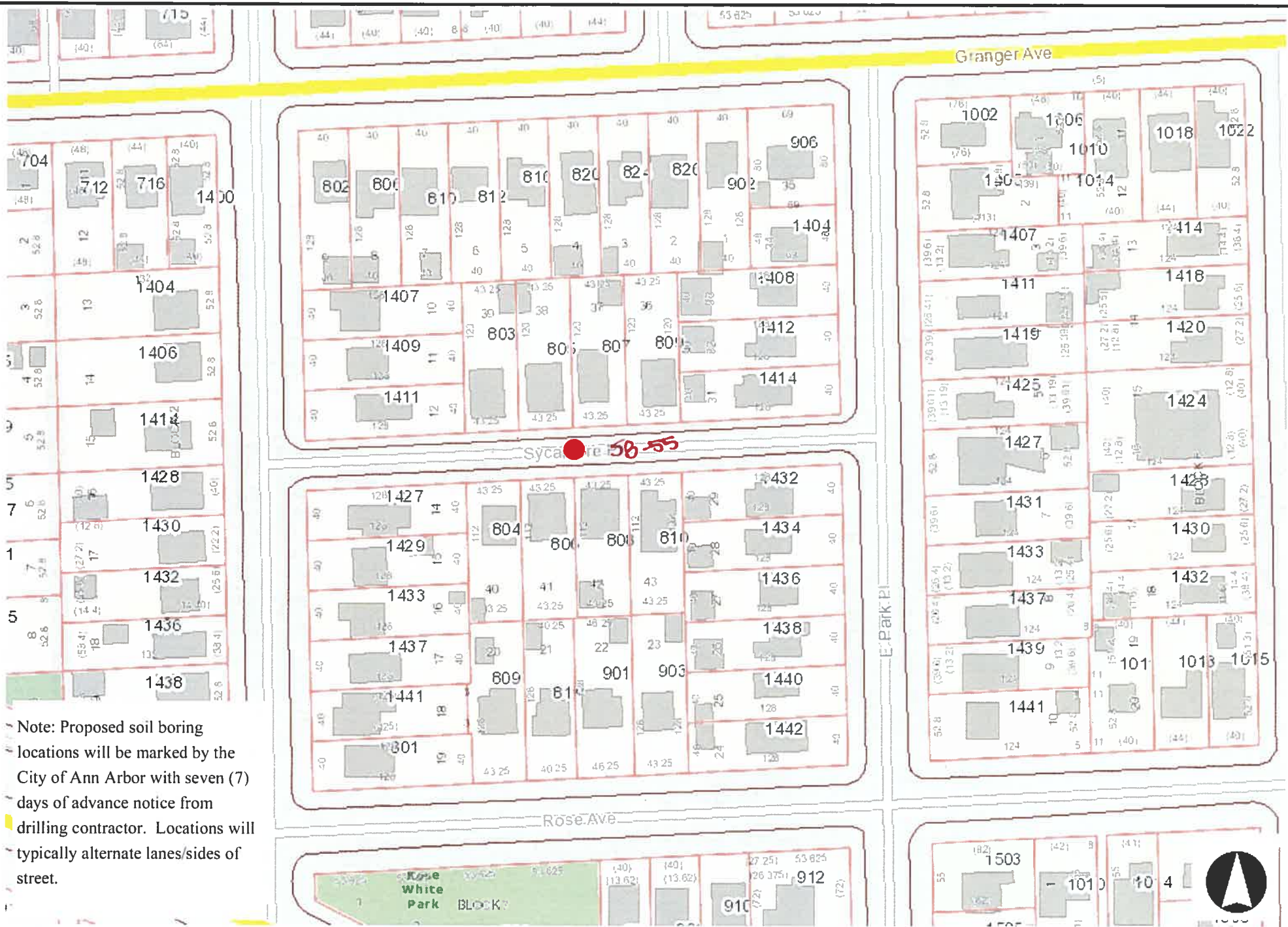

Note: Proposed soil boring locations will be marked by the City of Ann Arbor with seven (7) days of advance notice from drilling contractor. Locations will typically alternate lanes/sides of street.



SOIL BORING LOCATION MAP
Sycamore/White St/E Par Pl

Scale is 11,200

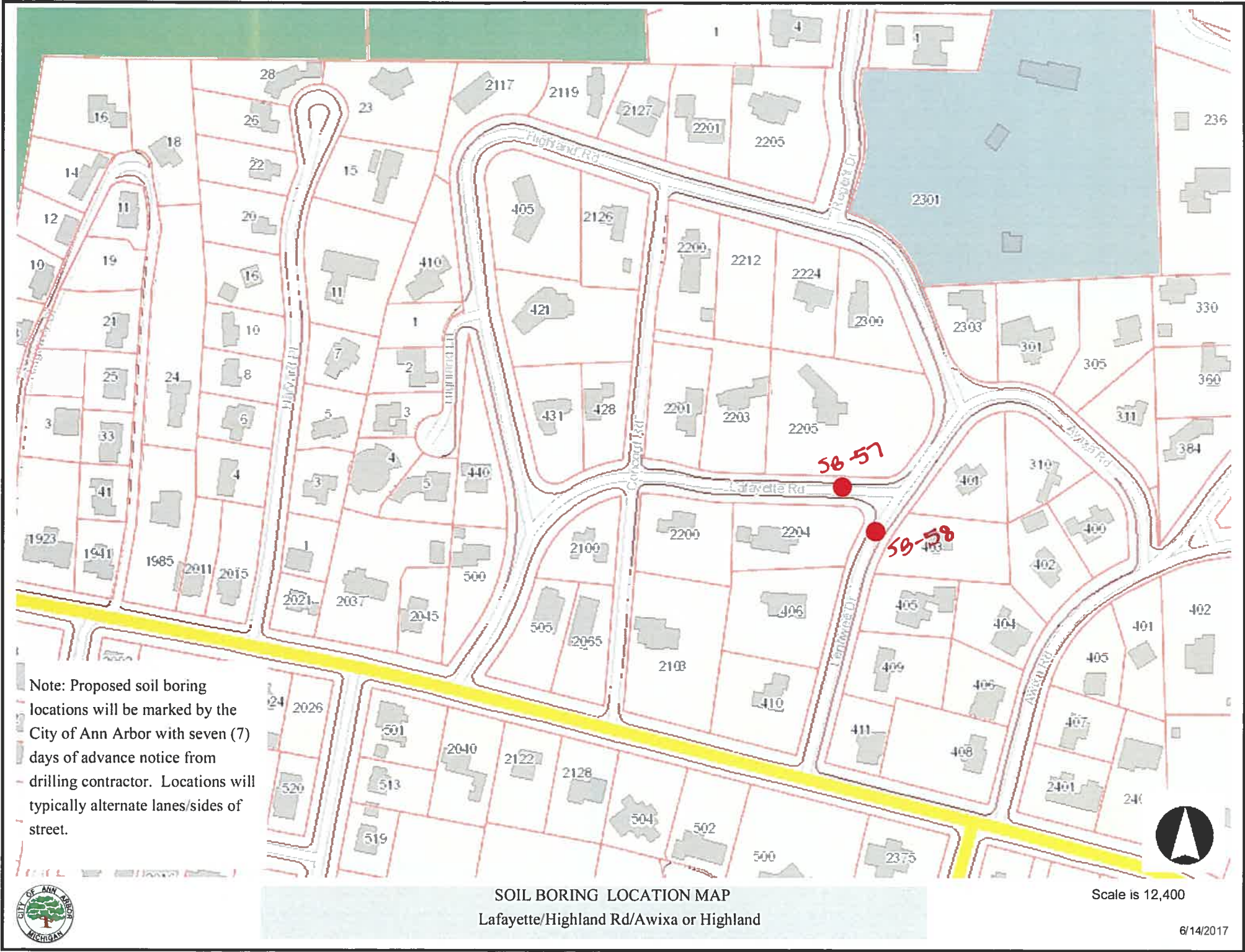

Note: Proposed soil boring locations will be marked by the City of Ann Arbor with seven (7) days of advance notice from drilling contractor. Locations will typically alternate lanes/sides of street.

SOIL BORING LOCATION MAP
Lafayette/Highland Rd/Awixa or Highland

Scale is 12,400





TTL Associates, Inc.
 1915 N 12th Street
 Toledo, Ohio 43624
 Telephone: 419-324-2222
 Fax: 419-241-1808

BORING NUMBER SB-52

PAGE 1 OF 1

CLIENT City of Ann Arbor	PROJECT NAME Geotechnical Bundle #1
PROJECT NUMBER 15047.02	PROJECT LOCATION Ann Arbor, MI
DRILLING CONTRACTOR TTL Associates CW TB	RIG NO. 844 GROUND ELEVATION
DRILLING METHOD 3 in. SSA	GROUND WATER LEVELS:
DATE STARTED 1/26/18 COMPLETED 1/26/18	AT TIME OF DRILLING None
LOGGED BY KKC CHECKED BY KCH	AT END OF DRILLING None
NOTES Horman Court	0hrs AFTER DRILLING Backfilled w/Cuttings, Chips, and Patch

ELEVATION (ft)	DEPTH (ft)	GRAPHIC LOG	MATERIAL DESCRIPTION	SAMPLE TYPE NUMBER	RECOVERY % (RQD)	BLOW COUNTS (N VALUE)	UNCONF. COMP. STR. (tsf)	DRY UNIT WT. (pcf)	SPT N VALUE			
									PL	MC	LL	
	0		ASPHALT - 5.5 Inches						20	40	60	80
			Moist Medium Dense Brown SILTY SAND w/Gravel(SM)	SS 1	67	13-17-9 (26)	NP					
			Moist Very Loose Brown POORLY GRADED SAND w/Trace Silt (SP)	SS 2	100	3-2-2 (4)	NP					
	5		@6': Loose	SS 3	100	3-3-2 (5)	NP					
			Moist Medium Dense Brown POORLY GRADED SAND w/Trace Silt (SP)	SS 4	100	7-8-8 (16)	NP					
	10		Bottom of hole at 10.0 feet.									



TTL Associates, Inc.
 1915 N 12th Street
 Toledo, Ohio 43624
 Telephone: 419-324-2222
 Fax: 419-241-1808

BORING NUMBER SB-53

PAGE 1 OF 1

CLIENT <u>City of Ann Arbor</u>	PROJECT NAME <u>Geotechnical Bundle #1</u>
PROJECT NUMBER <u>15047.02</u>	PROJECT LOCATION <u>Ann Arbor, MI</u>
DRILLING CONTRACTOR <u>TTL Associates CW TB</u>	RIG NO. <u>844</u> GROUND ELEVATION _____
DRILLING METHOD <u>3 in. SSA</u>	GROUND WATER LEVELS:
DATE STARTED <u>1/26/18</u> COMPLETED <u>1/26/18</u>	AT TIME OF DRILLING <u>None</u>
LOGGED BY <u>KKC</u> CHECKED BY <u>KCH</u>	AT END OF DRILLING <u>None</u>
NOTES <u>South Forest Avenue</u>	0hrs AFTER DRILLING <u>Backfilled w/Cuttings, Chips, and Patch</u>

ELEVATION (ft)	DEPTH (ft)	GRAPHIC LOG	MATERIAL DESCRIPTION	SAMPLE TYPE NUMBER	RECOVERY % (RQD)	BLOW COUNTS (N VALUE)	UNCONF. COMP. STR. (tsf)	DRY UNIT WT. (pcf)	SPT N VALUE ▲								
									PL	MC	LL						
	0		ASPHALT - 13 Inches														
	1.1'		Moist Very Dense Brown POORLY GRADED SAND w/Trace Gravel and Silt (SP)	SS 1	89	14-29-29 (58)	NP										
	3.0'		Moist Loose Brown SILTY SAND w/Trace Gravel (SM)	SS 2	100	3-3-3 (6)	NP										
	6.0'		Moist Medium Dense Brown POORLY GRADED SAND w/Gravel and Trace Silt (SP)	SS 3	100	6-11-7 (18)	NP										
	10'			SS 4	100	11-10-9 (19)	NP										
	12.0'		Moist Loose Brown POORLY GRADED SAND w/Trace Gravel and Silt (SP)	SS 5	100	7-7-7 (14)	NP										
	15.0'			SS 6	83	5-3-4 (7)	NP										
			Bottom of hole at 15.0 feet.														

TTL_GEOTECH_STANDARD_15047.02.GPJ GINT US LAB.GDT 2/5/18



TTL Associates, Inc.
 1915 N 12th Street
 Toledo, Ohio 43624
 Telephone: 419-324-2222
 Fax: 419-241-1808

BORING NUMBER SB-54

PAGE 1 OF 1

CLIENT City of Ann Arbor	PROJECT NAME Geotechnical Bundle #1
PROJECT NUMBER 15047.02	PROJECT LOCATION Ann Arbor, MI
DRILLING CONTRACTOR TTL Associates TB AO	RIG NO. 844 GROUND ELEVATION
DRILLING METHOD 2-1/4 in. HSA	GROUND WATER LEVELS:
DATE STARTED 10/5/17 COMPLETED 10/5/17	AT TIME OF DRILLING None
LOGGED BY KKC CHECKED BY KCH	AT END OF DRILLING None
NOTES Brookwood Place	0hrs AFTER DRILLING Backfilled w/Cuttings, Chips, and Patch

ELEVATION (ft)	DEPTH (ft)	GRAPHIC LOG	MATERIAL DESCRIPTION	SAMPLE TYPE NUMBER	RECOVERY % (RQD)	BLOW COUNTS (N VALUE)	UNCONF. COMP. STR. (tsf)	DRY UNIT WT. (pcf)	PL MC LL			
									20	40	60	80
	0								▲ SPT N VALUE ▲			
			ASPHALT - 4 Inches									
			CRUSHED STONE - 4 Inches	SS 1	78	7-8-9 (17)	NP					
			Moist Medium Dense Brown SILTY SAND w/Trace Gravel (SM)	SS 2	100	6-6-4 (10)	NP					
			Moist Loose Brown WELL GRADED SAND w/Silt and Trace Gravel (SW-SM) @3.5': Very Loose	SS 3	100	2-2-2 (4)	NP					
	5		Bottom of hole at 5.0 feet.									



TTL Associates, Inc.
 1915 N 12th Street
 Toledo, Ohio 43624
 Telephone: 419-324-2222
 Fax: 419-241-1808

BORING NUMBER SB-55

CLIENT City of Ann Arbor	PROJECT NAME Geotechnical Bundle #1
PROJECT NUMBER 15047.02	PROJECT LOCATION Ann Arbor, MI
DRILLING CONTRACTOR TTL Associates TB AO	RIG NO. 844 GROUND ELEVATION _____
DRILLING METHOD 2-1/4 in. HSA	GROUND WATER LEVELS:
DATE STARTED 10/5/17 COMPLETED 10/5/17	▽ AT TIME OF DRILLING 6.0 ft
LOGGED BY KKC CHECKED BY KCH	▼ AT END OF DRILLING 8.0 ft
NOTES Sycamore Place	0hrs AFTER DRILLING Backfilled w/Cuttings, Chips, and Patch

ELEVATION (ft)	DEPTH (ft)	GRAPHIC LOG	MATERIAL DESCRIPTION	SAMPLE TYPE NUMBER	RECOVERY % (RQD)	BLOW COUNTS (N VALUE)	UNCONF. COMP. STR. (tsf)	DRY UNIT WT. (pcf)	PL MC LL			
									20	40	60	80
	0		ASPHALT - 6 Inches									
			Moist Loose Brown SILTY SAND w/Gravel (SM)	SS 1	67	3-4-5 (9)	NP		▲			
			Moist Medium Dense Brown SILTY SAND w/Trace Gravel (SM)	SS 2	78	5-7-11 (18)	NP		▲			
			Moist Dense Brown POORLY GRADED SAND w/Trace Gravel and Silt (SP)	SS 3	100	10-14-19 (33)	NP		▲			
			▽ @6': Wet, (Free Water Noted in Jar)	SS 4	100	14-15-17 (32)	NP		▲			
			▼	SS 5	100	10-11-13 (24)	NP		▲			
	10		Bottom of hole at 10.0 feet.									

TTL_GEOTECH_STANDARD_15047.02.GPJ GINT US LAB.GDT 2/5/18



TTL Associates, Inc.
 1915 N 12th Street
 Toledo, Ohio 43624
 Telephone: 419-324-2222
 Fax: 419-241-1808

BORING NUMBER SB-57

PAGE 1 OF 1

CLIENT City of Ann Arbor	PROJECT NAME Geotechnical Bundle #1
PROJECT NUMBER 15047.02	PROJECT LOCATION Ann Arbor, MI
DRILLING CONTRACTOR TTL Associates TB AO	RIG NO. 844 GROUND ELEVATION
DRILLING METHOD 2-1/4 in. HSA	GROUND WATER LEVELS:
DATE STARTED 10/5/17 COMPLETED 10/5/17	AT TIME OF DRILLING None
LOGGED BY KKC CHECKED BY KCH	AT END OF DRILLING None
NOTES Lafayette Road	0hrs AFTER DRILLING Backfilled w/Cuttings, Chips, and Patch

ELEVATION (ft)	DEPTH (ft)	GRAPHIC LOG	MATERIAL DESCRIPTION	SAMPLE TYPE NUMBER	RECOVERY % (RQD)	BLOW COUNTS (N VALUE)	UNCONF. COMP. STR. (tsf)	DRY UNIT WT. (pcf)	PL MC LL			
									20	40	60	80
	0		ASPHALT - 6 Inches									
			Moist Stiff Brown LEAN CLAY w/Sand (CL)	SS 1	100	17-6-6 (12)	3.25			10		
			@3.5': Very Stiff, Gray/Brown	SS 2	100	4-6-9 (15)	3.50			11		
	5			SS 3	100	5-7-10 (17)	3.00			11		
			Moist Medium Dense Brown CLAYEY SAND w/Trace Gravel (SC)	SS 4	11	10-11-12 (23)	NP					
			Moist Very Stiff Brown LEAN CLAY w/Sand and Trace Gravel (CL)	SS 5	100	7-9-15 (24)	4.50			12		
	10		@11': Gray/Brown	SS 6	100	7-8-10 (18)	4.00			10		
			Moist Very Dense Brown SILTY SAND w/Dolomite Fragments (SM)	SS 7	100	50/5"	NP					
	15		Bottom of hole at 15.0 feet.									

TTL_GEOTECH_STANDARD_15047.02.GPJ GINT US LAB.GDT 2/5/18



TTL Associates, Inc.
 1915 N 12th Street
 Toledo, Ohio 43624
 Telephone: 419-324-2222
 Fax: 419-241-1808

BORING NUMBER SB-58

PAGE 1 OF 1

CLIENT City of Ann Arbor	PROJECT NAME Geotechnical Bundle #1
PROJECT NUMBER 15047.02	PROJECT LOCATION Ann Arbor, MI
DRILLING CONTRACTOR TTL Associates CW TB	RIG NO. 844 GROUND ELEVATION
DRILLING METHOD 3 in. SSA	GROUND WATER LEVELS:
DATE STARTED 1/26/18 COMPLETED 1/26/18	AT TIME OF DRILLING None
LOGGED BY KKC CHECKED BY KCH	AT END OF DRILLING None
NOTES Lafayette Road	0hrs AFTER DRILLING Backfilled w/Cuttings, Chips, and Patch

ELEVATION (ft)	DEPTH (ft)	GRAPHIC LOG	MATERIAL DESCRIPTION	SAMPLE TYPE NUMBER	RECOVERY % (RQD)	BLOW COUNTS (N VALUE)	UNCONF. COMP. STR. (tsf)	DRY UNIT WT. (pcf)	PL MC LL			
									20	40	60	80
	0		ASPHALT - 3 Inches									
			Moist Brown SILTY SAND w/Gravel (SM)									
			Moist Very Dense Brown POORLY GRADED SAND w/Silt (SP/SM)	SS 1	100	16-22-29 (51)	NP					
			Moist Stiff Brown LEAN CLAY w/Sand (CL)	SS 2	100	4-7-6 (13)	4.25	13				
			Moist Dense Brown POORLY GRADED SAND w/Silt (SP/SM)	SS 3	100	7-7-11 (18)	NP					
			Moist Dense Brown POORLY GRADED SAND w/Trace Silt (SP)	SS 4	100	6-8-9 (17)	NP					
				SS 5	100	8-10-11 (21)	NP					
				SS 6	100	4-10-12 (22)	NP					
				SS 7	100	8-10-13 (23)	NP					
			Bottom of hole at 16.0 feet.									

TTL_GEOTECH_STANDARD_15047.02.GPJ GINT US LAB.GDT 2/5/18



TTL Associates, Inc.
 1915 N 12th Street
 Toledo, Ohio 43624
 Telephone: 419-324-2222
 Fax: 419-241-1808

GRAIN SIZE DISTRIBUTION

CLIENT City of Ann Arbor

PROJECT NAME Geotechnical Bundle #1

PROJECT NUMBER 15047.02

PROJECT LOCATION Ann Arbor, MI

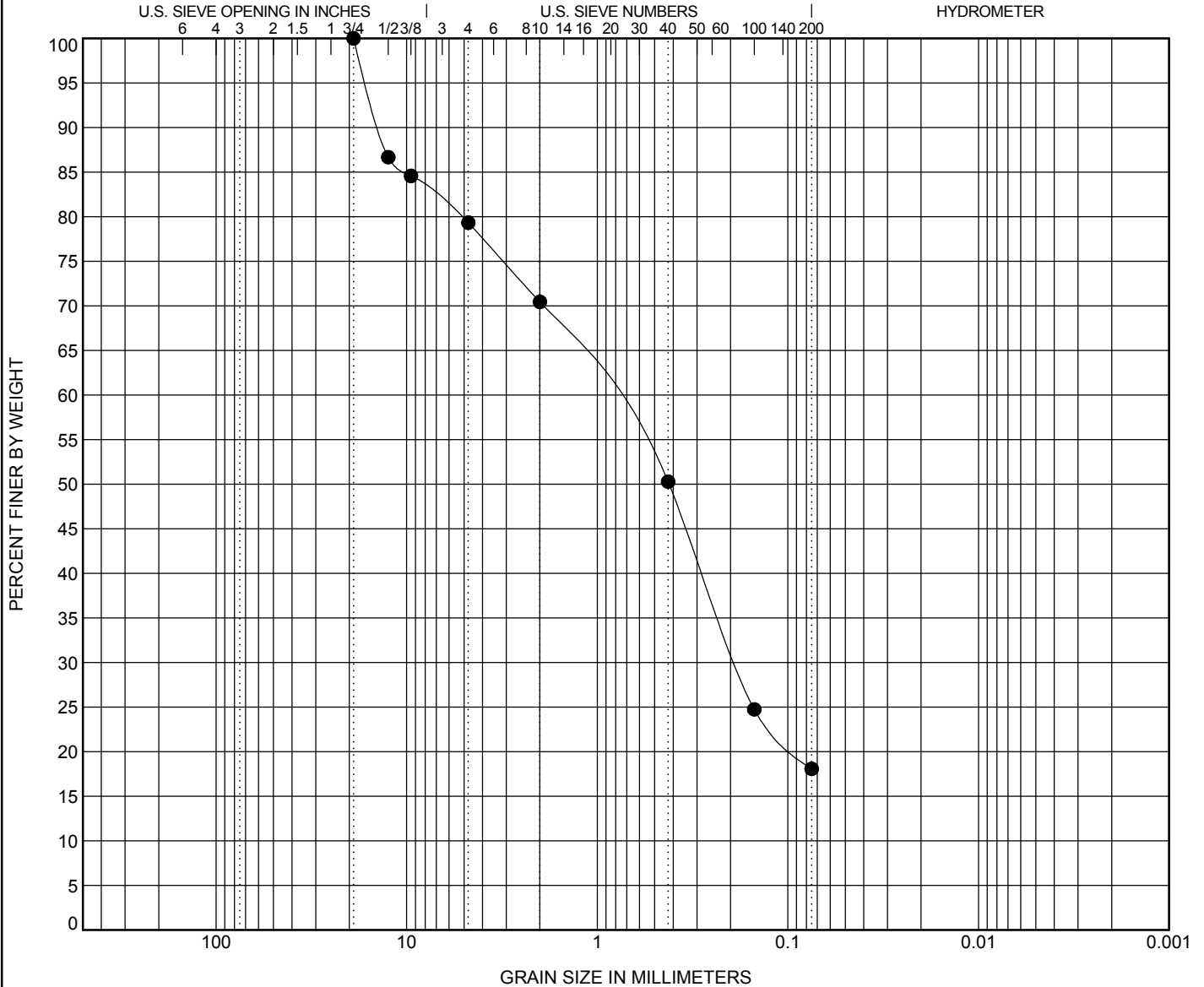

COBBLES	GRAVEL		SAND			SILT OR CLAY
	coarse	fine	coarse	medium	fine	

Specimen Identification		USCS Classification					LL	PL	PI	Cc	Cu	
●	SB-52	1.0	SILTY SAND with GRAVEL (SM)					NP	NP	NP		
Specimen Identification		D100	D60	D30	D10	%Gravel	%Sand	%Silt	%Clay			
●	SB-52	1.0	19	0.897	0.186	20.7	61.3	18.1				

GRAIN SIZE 15047.02.GPJ GINT US LAB.GDT 2/5/18



TTL Associates, Inc.
 1915 N 12th Street
 Toledo, Ohio 43624
 Telephone: 419-324-2222
 Fax: 419-241-1808

GRAIN SIZE DISTRIBUTION

CLIENT City of Ann Arbor

PROJECT NAME Geotechnical Bundle #1

PROJECT NUMBER 15047.02

PROJECT LOCATION Ann Arbor, MI

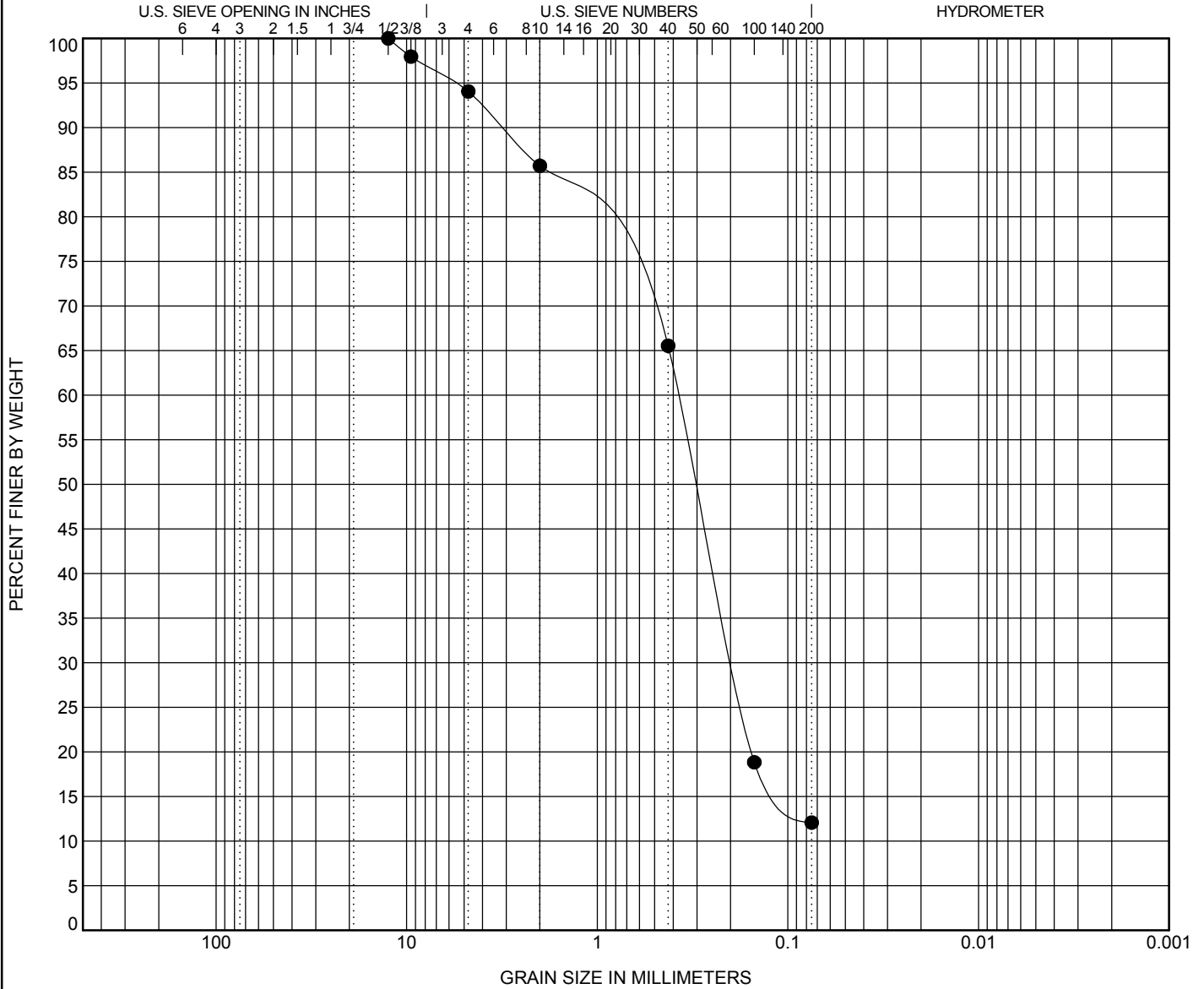

COBBLES	GRAVEL		SAND			SILT OR CLAY
	coarse	fine	coarse	medium	fine	

Specimen Identification	USCS Classification	LL	PL	PI	Cc	Cu
● SB-53 3.5	SILTY SAND (SM)	NP	NP	NP	1.6	6.2

Specimen Identification	D100	D60	D30	D10	%Gravel	%Sand	%Silt	%Clay
● SB-53 3.5	12.5	0.376	0.192		5.9	82.0	12.1	

GRAIN SIZE 15047.02.GPJ GINT US LAB.GDT 2/5/18



TTL Associates, Inc.
 1915 N 12th Street
 Toledo, Ohio 43624
 Telephone: 419-324-2222
 Fax: 419-241-1808

GRAIN SIZE DISTRIBUTION

CLIENT City of Ann Arbor

PROJECT NAME Geotechnical Bundle #1

PROJECT NUMBER 15047.02

PROJECT LOCATION Ann Arbor, MI

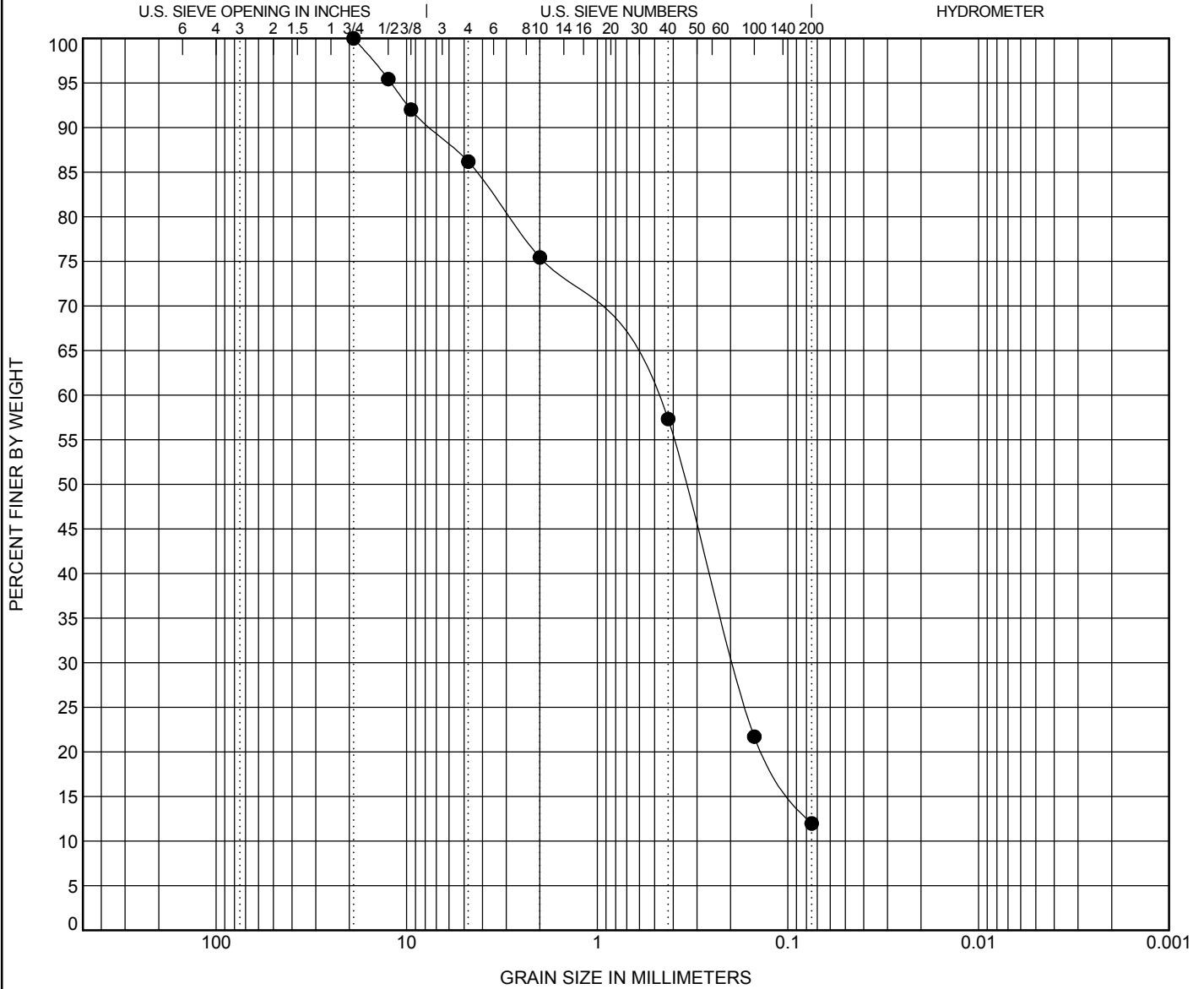

COBBLES	GRAVEL		SAND			SILT OR CLAY
	coarse	fine	coarse	medium	fine	

Specimen Identification	USCS Classification	LL	PL	PI	Cc	Cu
● SB-54 3.5	WELL-GRADED SAND with SILT (SW-SM)	NP	NP	NP	1.0	8.2

Specimen Identification	D100	D60	D30	D10	%Gravel	%Sand	%Silt	%Clay
● SB-54 3.5	19	0.534	0.191		13.8	74.2	12.0	

GRAIN SIZE 15047.02.GPJ GINT US LAB.GDT 2/5/18



TTL Associates, Inc.
 1915 N 12th Street
 Toledo, Ohio 43624
 Telephone: 419-324-2222
 Fax: 419-241-1808

GRAIN SIZE DISTRIBUTION

CLIENT City of Ann Arbor

PROJECT NAME Geotechnical Bundle #1

PROJECT NUMBER 15047.02

PROJECT LOCATION Ann Arbor, MI

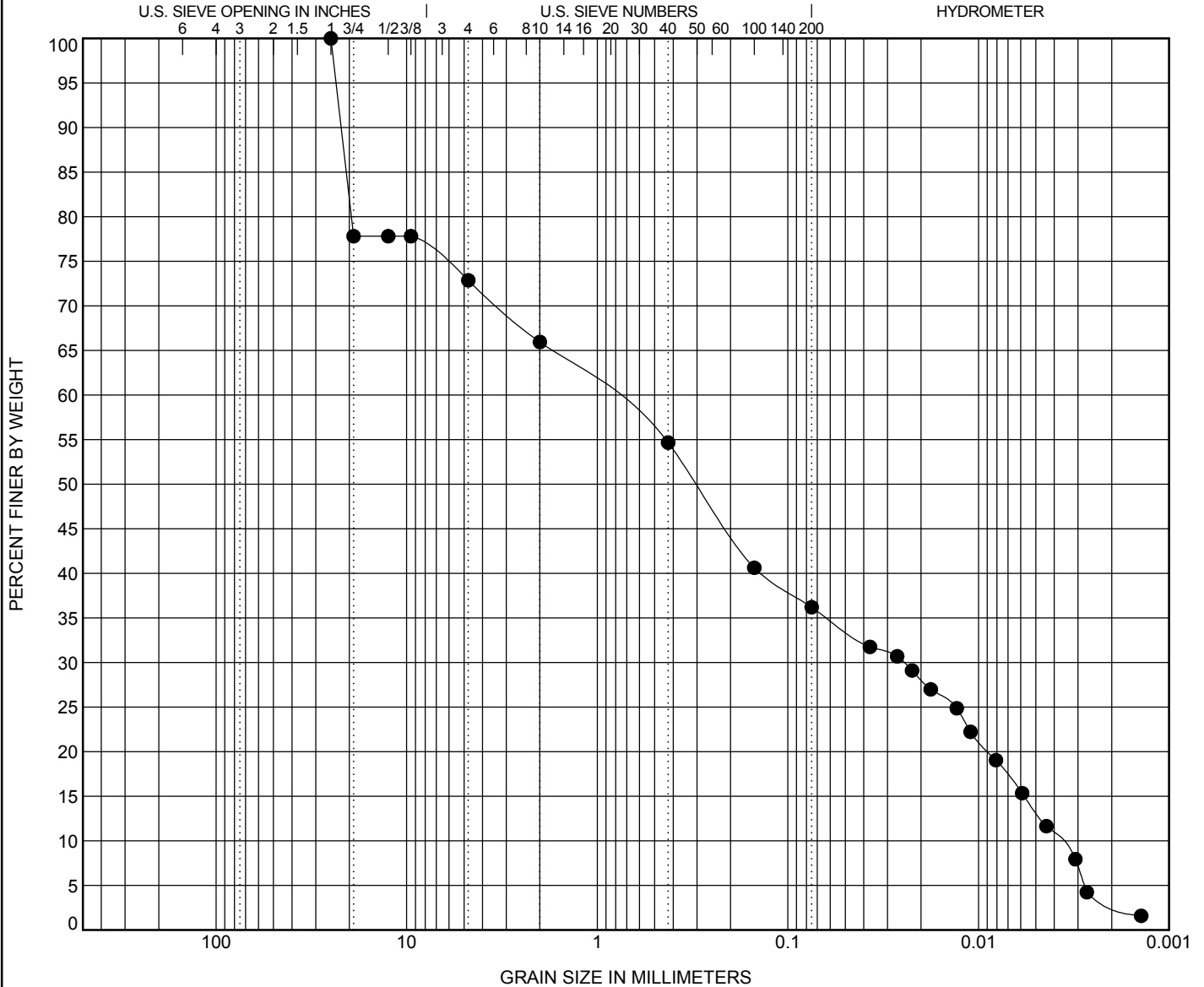

COBBLES	GRAVEL		SAND			SILT OR CLAY
	coarse	fine	coarse	medium	fine	

Specimen Identification	USCS Classification	LL	PL	PI	Cc	Cu
● SB-55 0.0	SILTY SAND with GRAVEL (SM)	NP	NP	NP	0.2	234.7

Specimen Identification	D100	D60	D30	D10	%Gravel	%Sand	%Silt	%Clay
● SB-55 0.0	25	0.884	0.025	0.004	27.1	36.7	22.9	13.3

GRAIN SIZE 15047.02.GPJ GINT US LAB.GDT 2/5/18



TTL Associates, Inc.
 1915 N 12th Street
 Toledo, Ohio 43624
 Telephone: 419-324-2222
 Fax: 419-241-1808

GRAIN SIZE DISTRIBUTION

CLIENT City of Ann Arbor

PROJECT NAME Geotechnical Bundle #1

PROJECT NUMBER 15047.02

PROJECT LOCATION Ann Arbor, MI

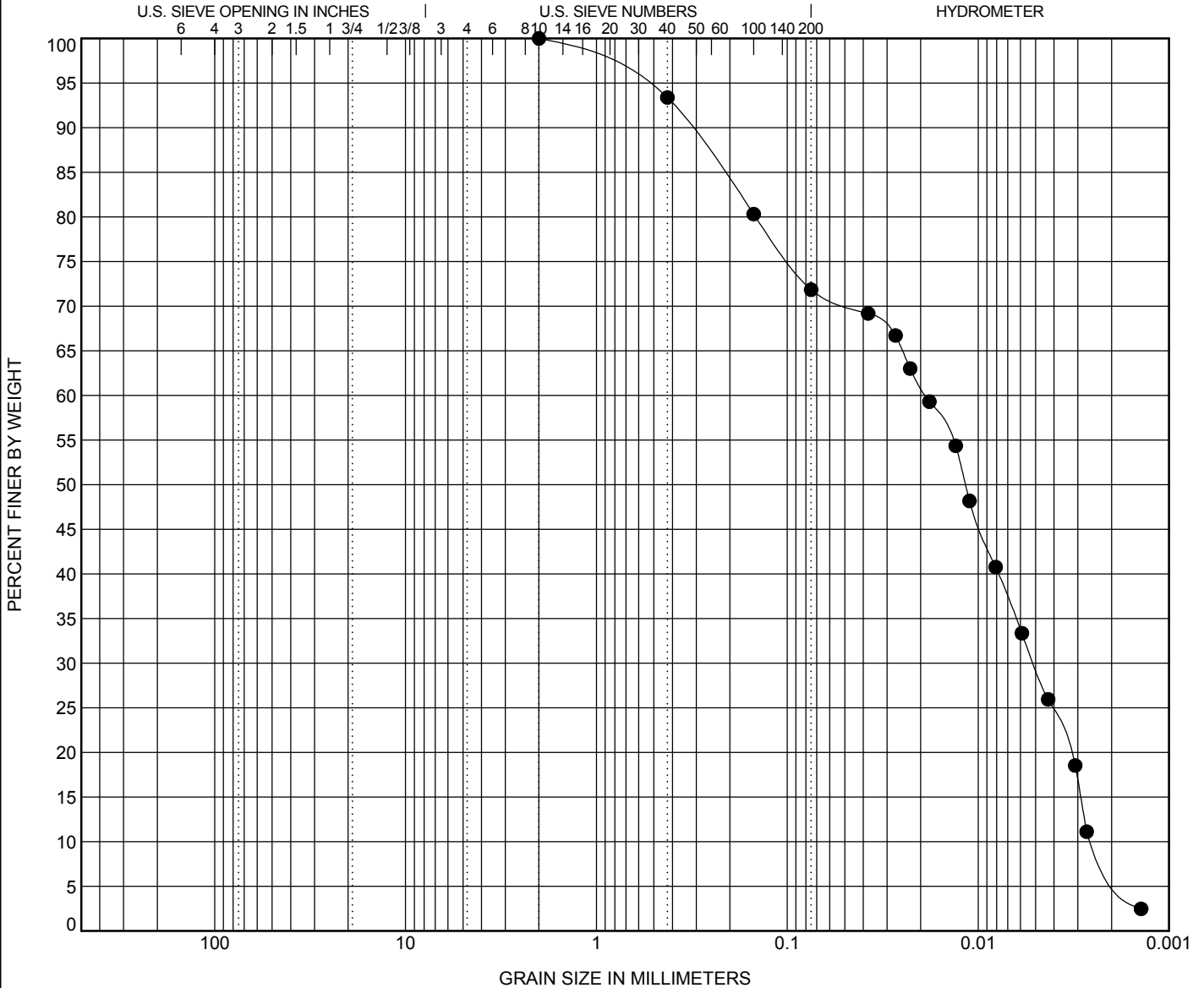

COBBLES	GRAVEL		SAND			SILT OR CLAY
	coarse	fine	coarse	medium	fine	

Specimen Identification	USCS Classification	LL	PL	PI	Cc	Cu
● SB-57 1.5	LEAN CLAY with SAND (CL)	22	14	8	0.6	7.6

Specimen Identification	D100	D60	D30	D10	%Gravel	%Sand	%Silt	%Clay
● SB-57 1.5	2	0.019	0.005	0.002	0.0	28.2	42.4	29.5

GRAIN SIZE 15047.02.GPJ GINT US LAB.GDT 2/5/18

ATTACHMENTS

**CITY OF ANN ARBOR
LIVING WAGE ORDINANCE DECLARATION OF COMPLIANCE**

The Ann Arbor Living Wage Ordinance (Section 1:811-1:821 of Chapter 23 of Title I of the Code) requires that an employer who is (a) a contractor providing services to or for the City for a value greater than \$10,000 for any twelve-month contract term, or (b) a recipient of federal, state, or local grant funding administered by the City for a value greater than \$10,000, or (c) a recipient of financial assistance awarded by the City for a value greater than \$10,000, shall pay its employees a prescribed minimum level of compensation (i.e., Living Wage) for the time those employees perform work on the contract or in connection with the grant or financial assistance. The Living Wage must be paid to these employees for the length of the contract/program.

Companies employing fewer than 5 persons and non-profits employing fewer than 10 persons are exempt from compliance with the Living Wage Ordinance. If this exemption applies to your company/non-profit agency please check here No. of employees__

The Contractor or Grantee agrees:

- (a) To pay each of its employees whose wage level is not required to comply with federal, state or local prevailing wage law, for work covered or funded by a contract with or grant from the City, no less than the Living Wage. The current Living Wage is defined as \$13.22/hour for those employers that provide employee health care (as defined in the Ordinance at Section 1:815 Sec. 1 (a)), or no less than \$14.75/hour for those employers that do not provide health care. The Contractor or Grantor understands that the Living Wage is adjusted and established annually on April 30 in accordance with the Ordinance and covered employers shall be required to pay the adjusted amount thereafter to be in compliance with Section 1:815(3).

Check the applicable box below which applies to your workforce

- Employees who are assigned to any covered City contract/grant will be paid at or above the applicable living wage without health benefits
- Employees who are assigned to any covered City contract/grant will be paid at or above the applicable living wage with health benefits

- (b) To post a notice approved by the City regarding the applicability of the Living Wage Ordinance in every work place or other location in which employees or other persons contracting for employment are working.
- (c) To provide to the City payroll records or other documentation within ten (10) business days from the receipt of a request by the City.
- (d) To permit access to work sites to City representatives for the purposes of monitoring compliance, and investigating complaints or non-compliance.
- (e) To take no action that would reduce the compensation, wages, fringe benefits, or leave available to any employee covered by the Living Wage Ordinance or any person contracted for employment and covered by the Living Wage Ordinance in order to pay the living wage required by the Living Wage Ordinance.

The undersigned states that he/she has the requisite authority to act on behalf of his/her employer in these matters and has offered to provide the services or agrees to accept financial assistance in accordance with the terms of the Living Wage Ordinance. The undersigned certifies that he/she has read and is familiar with the terms of the Living Wage Ordinance, obligates the Employer/Grantee to those terms and acknowledges that if his/her employer is found to be in violation of Ordinance it may be subject to civil penalties and termination of the awarded contract or grant of financial assistance.

Company Name

Street Address

Signature of Authorized Representative

Date

City, State, Zip

Print Name and Title

Phone/Email address

**CITY OF ANN ARBOR
LIVING WAGE ORDINANCE**

RATE EFFECTIVE APRIL 30, 2018 - ENDING APRIL 29, 2019

\$13.22 per hour

If the employer provides health care benefits*

\$14.75 per hour

If the employer does **NOT** provide health care benefits*

Employers providing services to or for the City of Ann Arbor or recipients of grants or financial assistance from the City of Ann Arbor for a value of more than \$10,000 in a twelve-month period of time must pay those employees performing work on a City of Ann Arbor contract or grant, the above living wage.

ENFORCEMENT

The City of Ann Arbor may recover back wages either administratively or through court action for the employees that have been underpaid in violation of the law. Persons denied payment of the living wage have the right to bring a civil action for damages in addition to any action taken by the City.

Violation of this Ordinance is punishable by fines of not more than \$500/violation plus costs, with each day being considered a separate violation. Additionally, the City of Ann Arbor has the right to modify, terminate, cancel or suspend a contract in the event of a violation of the Ordinance.

* Health Care benefits include those paid for by the employer or making an employer contribution toward the purchase of health care. The employee contribution must not exceed \$.50 an hour for an average work week; and the employer cost or contribution must equal no less than \$1/hr for the average work week.

The Law Requires Employers to Display This Poster Where Employees Can Readily See It.

**For Additional Information or to File a Complaint contact
Colin Spencer at 734/794-6500 or cspencer@a2gov.org**



Vendor Conflict of Interest Disclosure Form

All vendors interested in conducting business with the City of Ann Arbor must complete and return the Vendor Conflict of Interest Disclosure Form in order to be eligible to be awarded a contract. Please note that all vendors are subject to comply with the City of Ann Arbor's conflict of interest policies as stated within the certification section below.

If a vendor has a relationship with a City of Ann Arbor official or employee, an immediate family member of a City of Ann Arbor official or employee, the vendor shall disclose the information required below.

1. No City official or employee or City employee's immediate family member has an ownership interest in vendor's company or is deriving personal financial gain from this contract.
2. No retired or separated City official or employee who has been retired or separated from the City for less than one (1) year has an ownership interest in vendor's Company.
3. No City employee is contemporaneously employed or prospectively to be employed with the vendor.
4. Vendor hereby declares it has not and will not provide gifts or hospitality of any dollar value or any other gratuities to any City employee or elected official to obtain or maintain a contract.
5. Please note any exceptions below:

Conflict of Interest Disclosure*	
Name of City of Ann Arbor employees, elected officials or immediate family members with whom there may be a potential conflict of interest.	<input type="checkbox"/> Relationship to employee <hr style="border: 0; border-top: 1px solid black;"/> <input type="checkbox"/> Interest in vendor's company <input type="checkbox"/> Other (please describe in box below)

*Disclosing a potential conflict of interest does not disqualify vendors. In the event vendors do not disclose potential conflicts of interest and they are detected by the City, vendor will be exempt from doing business with the City.

I certify that this Conflict of Interest Disclosure has been examined by me and that its contents are true and correct to my knowledge and belief and I have the authority to so certify on behalf of the Vendor by my signature below:		
Vendor Name	Vendor Phone Number	
Signature of Vendor Authorized Representative	Date	Printed Name of Vendor Authorized Representative

Questions about this form? Contact Procurement Office City of Ann Arbor Phone: 734/794-6500, procurement@a2gov.org

CITY OF ANN ARBOR NON-DISCRIMINATION ORDINANCE

Relevant provisions of Chapter 112, Nondiscrimination, of the Ann Arbor City Code are included below. You can review the entire ordinance at [www. a2gov.org/departments/city-clerk](http://www.a2gov.org/departments/city-clerk)

Intent: It is the intent of the city that no individual be denied equal protection of the laws; nor shall any individual be denied the enjoyment of his or her civil or political rights or be discriminated against because of actual or perceived age, arrest record, color, disability, educational association, familial status, family responsibilities, gender expression, gender identity, genetic information, height, HIV status, marital status, national origin, political beliefs, race, religion, sex, sexual orientation, source of income, veteran status, victim of domestic violence or stalking, or weight.

Discriminatory Employment Practices: No person shall discriminate in the hire, employment, compensation, work classifications, conditions or terms, promotion or demotion, or termination of employment of any individual. No person shall discriminate in limiting membership, conditions of membership or termination of membership in any labor union or apprenticeship program.

Discriminatory Effects: No person shall adopt, enforce or employ any policy or requirement which has the effect of creating unequal opportunities according to actual or perceived age, arrest record, color, disability, educational association, familial status, family responsibilities, gender expression, gender identity, genetic information, height, HIV status, marital status, national origin, political beliefs, race, religion, sex, sexual orientation, source of income, veteran status, victim of domestic violence or stalking, or weight for an individual to obtain housing, employment or public accommodation, except for a bona fide business necessity. Such a necessity does not arise due to a mere inconvenience or because of suspected objection to such a person by neighbors, customers or other persons.

Nondiscrimination by City Contractors: All contractors proposing to do business with the City of Ann Arbor shall satisfy the contract compliance administrative policy adopted by the City Administrator in accordance with the guidelines of this section. All city contractors shall ensure that applicants are employed and that employees are treated during employment in a manner which provides equal employment opportunity and tends to eliminate inequality based upon any classification protected by this chapter. All contractors shall agree not to discriminate against an employee or applicant for employment with respect to hire, tenure, terms, conditions, or privileges of employment, or a matter directly or indirectly related to employment, because of any applicable protected classification. All contractors shall be required to post a copy of Ann Arbor's Non-Discrimination Ordinance at all work locations where its employees provide services under a contract with the city.

Complaint Procedure: If any individual has a grievance alleging a violation of this chapter, he/she has 180 calendar days from the date of the individual's knowledge of the allegedly discriminatory action or 180 calendar days from the date when the individual should have known of the alleged discriminatory action to file a complaint with the city's Human Rights Commission. If an individual fails to file a complaint alleging a violation of this chapter within the specified time frame, the complaint will not be considered by the Human Rights Commission. The complaint should be made in writing to the Human Rights Commission. The complaint may be filed in person with the City Clerk, by e-mail (hrc@a2gov.org), by phone (734-794-6141) or by mail (Ann Arbor Human Rights Commission, PO Box 8647, Ann Arbor, MI 48107). The complaint must contain information about the alleged discrimination, such as name, address, phone number of the complainant and location, date and description of the alleged violation of this chapter.

Private Actions For Damages or Injunctive Relief: To the extent allowed by law, an individual who is the victim of discriminatory action in violation of this chapter may bring a civil action for appropriate injunctive relief or damages or both against the person(s) who acted in violation of this chapter.

THIS IS AN OFFICIAL GOVERNMENT NOTICE AND
MUST BE DISPLAYED WHERE EMPLOYEES CAN READILY SEE IT.

MICHIGAN DEPARTMENT OF TRANSPORTATION CERTIFIED PAYROLL

COMPLETION OF CERTIFIED PAYROLL FORM FULFILLS THE MINIMUM MDOT PREVAILING WAGE REQUIREMENTS

(1) NAME OF CONTRACTOR / SUBCONTRACTOR (CIRCLE ONE) (2) ADDRESS

(3) PAYROLL NO. (4) FOR WEEK ENDING (5) PROJECT AND LOCATION (6) CONTRACT ID

(a)	(b)	(c)	(d) DAY AND DATE							(e)	(f)	(g)	(h)	(i)	(j) DEDUCTIONS						(k)		
			HOURS WORKED ON PROJECT												TOTAL HOURS ON PROJECT	PROJECT RATE OF PAY	PROJECT RATE OF FRINGE PAY	GROSS PROJECT EARNED	GROSS WEEKLY EARNED	TOTAL WEEKLY HOURS WORKED ALL JOBS		FICA	FEDERAL
EMPLOYEE INFORMATION	WORK CLASSIFICATION	Hour Type								0			\$0.00									\$0.00	\$0.00
NAME:										0			\$0.00									\$0.00	\$0.00
ETH#GEN: ID #:	GROUP/CLASS #:	S								0			\$0.00									\$0.00	\$0.00
NAME:										0			\$0.00									\$0.00	\$0.00
ETH#GEN: ID #:	GROUP/CLASS #:	S								0			\$0.00									\$0.00	\$0.00
NAME:										0			\$0.00									\$0.00	\$0.00
ETH#GEN: ID #:	GROUP/CLASS #:	S								0			\$0.00									\$0.00	\$0.00
NAME:										0			\$0.00									\$0.00	\$0.00
ETH#GEN: ID #:	GROUP/CLASS #:	S								0			\$0.00									\$0.00	\$0.00
NAME:										0			\$0.00									\$0.00	\$0.00
ETH#GEN: ID #:	GROUP/CLASS #:	S								0			\$0.00									\$0.00	\$0.00
NAME:										0			\$0.00									\$0.00	\$0.00
ETH#GEN: ID #:	GROUP/CLASS #:	S								0			\$0.00									\$0.00	\$0.00
NAME:										0			\$0.00									\$0.00	\$0.00

Date _____

I, _____ (Name of Signatory Party) _____ (Title)

do hereby state:

(1) That I pay or supervise the payment of the persons employed by

_____ on the _____ (Contractor or Subcontractor)
 _____; that during the payroll period commencing on the _____ (Building or Work)
 _____ day of _____, _____, and ending the _____ day of _____, _____,
 all persons employed on said project have been paid the full weekly wages earned, that no rebates have been or will be made either directly or indirectly to or on behalf of said

_____ from the full _____ (Contractor or Subcontractor)

weekly wages earned by any person and that no deductions have been made either directly or indirectly from the full wages earned by any person, other than permissible deductions as defined in Regulations, Part 3 (29 C.F.R. Subtitle A), issued by the Secretary of Labor under the Copeland Act, as amended (48 Stat. 948, 63 Stat. 108, 72 Stat. 967; 76 Stat. 357; 40 U.S.C. § 3145), and described below:

(2) That any payrolls otherwise under this contract required to be submitted for the above period are correct and complete; that the wage rates for laborers or mechanics contained therein are not less than the applicable wage rates contained in any wage determination incorporated into the contract; that the classifications set forth therein for each laborer or mechanic conform with the work he performed.

(3) That any apprentices employed in the above period are duly registered in a bona fide apprenticeship program registered with a State apprenticeship agency recognized by the Bureau of Apprenticeship and Training, United States Department of Labor, or if no such recognized agency exists in a State, are registered with the Bureau of Apprenticeship and Training, United States Department of Labor.

(4) That:

(a) WHERE FRINGE BENEFITS ARE PAID TO APPROVED PLANS, FUNDS, OR PROGRAMS

- in addition to the basic hourly wage rates paid to each laborer or mechanic listed in the above referenced payroll, payments of fringe benefits as listed in the contract have been or will be made to appropriate programs for the benefit of such employees, except as noted in section 4(c) below.

(b) WHERE FRINGE BENEFITS ARE PAID IN CASH

- Each laborer or mechanic listed in the above referenced payroll has been paid, as indicated on the payroll, an amount not less than the sum of the applicable basic hourly wage rate plus the amount of the required fringe benefits as listed in the contract, except as noted in section 4(c) below.

(c) EXCEPTIONS

EXCEPTION (CRAFT)	EXPLANATION

REMARKS:

NAME AND TITLE	SIGNATURE

THE WILLFUL FALSIFICATION OF ANY OF THE ABOVE STATEMENTS MAY SUBJECT THE CONTRACTOR OR SUBCONTRACTOR TO CIVIL OR CRIMINAL PROSECUTION. SEE SECTION 1001 OF TITLE 18 AND SECTION 231 OF TITLE 31 OF THE UNITED STATES CODE.