

CITY OF ANN ARBOR  
INVITATION TO BID



Barton Drive Water Main Replacement and Resurfacing Project

ITB No. 4617

Due Date: Tuesday, March 31, 2020 10:00am (Local Time)

---

Public Services / Engineering Unit

Issued By:

City of Ann Arbor  
Procurement Unit  
301 E. Huron Street  
Ann Arbor, MI 48104

# TABLE OF CONTENTS

TABLE OF CONTENTS.....	TC-1
NOTICE OF PRE-BID CONFERENCE.....	NP-1
INSTRUCTIONS TO BIDDERS.....	IB-1 to 5
INVITATION TO BID.....	ITB-1 to 3
BID FORMS.....	BF-1 to 5
CONTRACT.....	C-5 to 4
BOND FORMS.....	B-1 to 2
GENERAL CONDITIONS.....	GC-1 to 16
STANDARD SPECIFICATIONS.....	SS-17
DETAILED SPECIFICATION.....	DS-1 to DS-103

	Project Schedule	DS-1
	Maintenance of Traffic	DS-5
	Coordination and Cooperation	DS-8
	Soil Erosion Control	DS-10
	Vacuum Street and Utility Structure Cleaning Equipment	DS-11
	Materials and Supplies Certifications	DS-12
	Contract Drawings/Plans	DS-13
	Soil Boring and Pavement Section Data	DS-14
	Working in the Rain or Dark	DS-15
	Quantities and Unit Prices	DS-16
	Water Main Installation and Testing	DS-17
	Asphaltic Seal Coatings Ductile Iron Pipe Fittings	DS-19
	Concrete Durability	DS-20
	HMA Paving	DS-25
	Acceptance of HMA Mixtures	DS-28
	HMA Application Estimate	DS-35
	Project Documentation Submittal Compliance	DS-36
	In-Situ Soils and Removal & Disposal of Contaminated Soils	DS-37
201	Project Supervision, Max. \$15,000	DS-40
202	General Conditions, Max. \$30,000	DS-43
203	Digital Audio Visual Coverage	DS-45
204	Minor Traffic Devices, Max. \$20,000	DS-48
205	Clean-up and Restoration, Special, Max \$10,000	DS-52
206	"No Parking" Signs	DS-53
207	Stump Removal, 8" or Larger, Modified	DS-54
208	Tree Trimming	DS-55
210	Remove Concrete Curb or Curb and Gutter - Any Type	DS-57
211	Remove Concrete Sidewalk and Drive - Any Thickness	DS-57
212	Cold Milling HMA Surface	DS-59
213	HMA Surface Remove	DS-60
214	Sidewalk Grading	DS-62
215	Sidewalk Ramp Grading	DS-62
216	Sewer, Any Size or Depth, Remove	DS-64
217	Drainage Structure, Any Size or Depth, Remove	DS-64
218	Additional Depth Structure Adjust/Repair	DS-65
219	Guardrail, Rem	DS-66
220	Remove Sanitary Sewer Lead	DS-67
221	Water Main Pipe Abandonment, Modified	DS-68
222	Fire Hydrant Assembly Abandonment	DS-68

223	Temporary Water Main Line Stop, Additional Rental Day	DS-70
224	Temporary Water Main Line Stop, Less than 8 inch	DS-70
225	Temporary 8 inch or 12 inch Water Main Line Stop	DS-70
230	Machine Grading, Modified	DS-71
231	Subgrade Undercutting - Type II	DS-73
232	Sand Subbase Course, Class II - C.I.P.	DS-74
233	21AA Limestone, C.I.P.	DS-74
234	Aggregate Base Course, 21AA - C.I.P.	DS-74
237	HMA Pavement Leveling / Top - LVSP	DS-76
238	HMA Approach	DS-76
239	Handpatching	DS-76
240	Concrete Curb or Curb and Gutter - All Types	DS-79
241	Concrete Curb or Curb and Gutter - All Types (High Early)	DS-79
242	4 Inch Concrete Sidewalk	DS-79
243	6 Inch Concrete Sidewalk or Sidewalk Ramp	DS-79
244	6 Inch Concrete Drive - High Early	DS-79
245	Detectable Warning, Cast In Place	DS-82
246	Integral Sidewalk Retaining Wall, under 6 inch	DS-84
247	Integral Sidewalk Retaining Wall, 6 inch to 18 inch	DS-84
248	Integral Sidewalk Retaining Wall, 19 inch to 36 inch	DS-84
250	Pavt Mrkg, Ovly Cold Plastic, 12 inch Crosswalk	DS-85
251	Pavt Mrkg, Ovly Cold Plastic, 24 inch Stop Bar	DS-85
252	Pavt Mrkg, Ovly Cold Plastic, Directional Arrow Sym, Bike	DS-85
253	Pavt Mrkg, Ovly Cold Plastic, Bike, Small Sym	DS-85
254	Pavt Mrkg, Ovly Cold Plastic, Sharrow Symbol	DS-85
255	Pavt Mrkg, Polyurea, 4 inch, White	DS-85
256	Pavt Mrkg, Polyurea, 4 inch, Yellow	DS-85
257	Pavt Mrkg, Polyurea, 6 inch, White	DS-85
258	Recessing Pavt Markg, Longit	DS-85
264	Pavt Mrkg Cover, Type R, Black	DS-86
265	Pavt Mrkg, Wet Reflec, Type R, Tape, 4 inch, White, Temp	DS-86
266	Pavt Mrkg, Wet Reflec, Type R, Tape, 4 inch, Yellow, Temp	DS-86
267	Pavt Mrkg, Wet Reflec, Type R, Tape, 6 inch Crosswalk	DS-86
268	Pavt Mrkg, Wet Reflec, Type R, Tape, 24 inch Stop Bar	DS-86
269	Temporary Curb for Bump-out	DS-86
270	Sign, Portable Changeable Message, Furnish and Operate	DS-86
271	Plastic Drum - Lighted, Furnish and Operate	DS-86
272	Barricade Type III - Lighted, Furnish and Operate	DS-86
273	Temporary Sign - Type B, Furnish and Operate	DS-86
274	Channelizing Device, 42 inch, Furnish and Operate	DS-86
275	Pedestrian Type II Barricade, Temp	DS-86
276	Sign Cover	DS-86
277	Temporary Pedestrian Ramp	DS-89
278	Temporary Pedestrian Mat	DS-89
279	Audible Message Device	DS-92
280	Fertilizer, Chemical Nutrient, Cl A	DS-95
281	Mulch Blanket, High Velocity	DS-95
282	Seeding, Mixture THM	DS-95
283	Topsoil Surface, Furn, 4 inch	DS-95
284	Fire Hydrant Assembly	DS-97
285	Underground Sprinkling Systems, Restore	DS-98
290	Certified Payroll Compliance and Reporting	DS-100
295	6-Inch Wrapped Underdrain	DS-102

APPENDIX - Barton Drive Soil Borings and Custom Manhole Casting..... APDX-1

**ATTACHMENTS**

*City of Ann Arbor Prevailing Wage Declaration Form*

*City of Ann Arbor Living Wage Forms*

*City of Ann Arbor Vendor Conflict of Interest Disclosure Form*

*City of Ann Arbor Non-Discrimination Ordinance Notice and Declaration Form*

## **NOTICE OF PRE-BID CONFERENCE**

A pre-bid conference for this project will be held on **Thursday, March 12, 2020 at 10:00am** at **Fourth Floor Conference Room, City Hall, 301 E Huron Street, Ann Arbor, Michigan 48107.**

Attendance at this conference is highly recommended. Administrative and technical questions regarding this project will be answered at this time. The pre-bid conference is for information only. Any answers furnished will not be official until verified in writing by the Financial Service Area, Procurement Unit. Answers that change or substantially clarify the bid will be affirmed in an addendum.

**Please email Jane Allen, Project Manager, at [jallen2@a2gov.org](mailto:jallen2@a2gov.org) by 8:00am, Thursday March 12, 2020 if you plan to attend so you can get an elevator pass when you arrive.**

# INSTRUCTIONS TO BIDDERS

## General

Work to be done under this Contract is generally described through the detailed specifications and must be completed fully in accordance with the contract documents. All work to be done under this Contract is located in or near the City of Ann Arbor.

Any Bid which does not conform fully to these instructions may be rejected.

## Preparation of Bids

Bids should be prepared providing a straight-forward, concise description of the Bidder's ability to meet the requirements of the ITB. Bids shall be written in ink or typewritten. No erasures are permitted. Mistakes may be crossed out and corrected and must be initialed and dated in ink by the person signing the Bid.

Bids must be submitted on the "Bid Forms" provided with each blank properly filled in. If forms are not fully completed it may disqualify the bid. No alternative bid will be considered unless alternative bids are specifically requested. If alternatives are requested, any deviation from the specification must be fully described, in detail on the "Alternate" section of Bid form.

Each person signing the Bid certifies that he/she is the person in the Bidder's firm/organization responsible for the decision as to the fees being offered in the Bid and has not and will not participated in any action contrary to the terms of this provision.

## Questions or Clarifications / Designated City Contacts

All questions regarding this ITB shall be submitted via email. Emailed questions and inquires will be accepted from any and all prospective Bidders in accordance with the terms and conditions of the ITB.

All questions shall be due on or before **Thursday, March 19, 2020, 10:00am** and should be addressed as follows:

Specification/Scope of Work questions emailed to [jallen2@a2gov.org](mailto:jallen2@a2gov.org)  
Bid Process and Compliance questions emailed to [cspencer@a2gov.org](mailto:cspencer@a2gov.org)

Any error, omissions or discrepancies in the specification discovered by a prospective contractor and/or service provider shall be brought to the attention of **Jane Allen** at [jallen2@a2gov.org](mailto:jallen2@a2gov.org) after discovery as soon as possible. Further, the contractor and/or service provide shall not be allowed to take advantage of errors, omissions or discrepancies in the specifications.

## Addenda

If it becomes necessary to revise any part of the ITB, notice of the Addendum will be posted to Michigan Inter-governmental Trade Network (MITN) [www.mitn.info](http://www.mitn.info) and/or City of Ann Arbor web site [www.A2gov.org](http://www.A2gov.org) for all parties to download.

Each Bidder must in its Bid, to avoid any miscommunications, acknowledge all addenda which it has received, but the failure of a Bidder to receive, or acknowledge receipt of; any addenda shall not relieve the Bidder of the responsibility for complying with the terms thereof.

The City will not be bound by oral responses to inquiries or written responses other than written

addenda.

## Bid Submission

All Bids are due and must be delivered to the City of Ann Arbor Procurement Unit on or before **Tuesday, March 31, 2020 at 10:00am EST**. Bids submitted late or via oral, telephonic, telegraphic, electronic mail or facsimile **will not** be considered or accepted.

Each Bidder must submit one (1) original Bid and **two ( 2 )** Bid copies in a sealed envelope clearly marked: **ITB No. 4617 Barton Drive Water Main Replacement and Resurfacing Project**.

### **Bids must be addressed and delivered to:**

City of Ann Arbor  
Procurement Unit,  
c/o Customer Services, 1<sup>st</sup> Floor  
301 East Huron Street  
Ann Arbor, MI 48107

All Bids received on or before the Due Date will be publicly opened and recorded immediately. No immediate decisions are rendered.

**The following forms provided within this ITB Document must be included in submitted bids.**

- **City of Ann Arbor Prevailing Wage Declaration of Compliance**
- **City of Ann Arbor Living Wage Ordinance Declaration of Compliance**
- **Vendor Conflict of Interest Disclosure Form**
- **City of Ann Arbor Non-Discrimination Ordinance Declaration of Compliance**

**Bids that fail to provide these forms listed above upon bid opening will be rejected as non-responsive and will not be considered for award.**

Hand delivered bids will be date/time stamped/signed by the Procurement Unit at the address above in order to be considered. Normal business hours are 9:00 a.m. to 3:00 p.m. Monday through Friday, excluding Holidays. The City will not be liable to any Bidder for any unforeseen circumstances, delivery or postal delays. Postmarking to the Due Date will not substitute for receipt of the Bid. Each Bidder is responsible for submission of their Bid.

Additional time for submission of bids past the stated due date and time will not be granted to a single Bidder; however, additional time may be granted to all Bidders when the City determines in its sole discretion that circumstances warrant it.

## Award

The City intends to award a Contract(s) to the lowest responsible Bidder(s). On multi-divisional contracts, separate divisions may be awarded to separate Bidders. The City may also utilize alternatives offered in the Bid Forms, if any, to determine the lowest responsible Bidder on each division, and award multiple divisions to a single Bidder, so that the lowest total cost is achieved for the City. For unit price bids, the Contract will be awarded based upon the unit prices and the lump sum prices stated by the bidder for the work items specified in the bid documents, with consideration given to any alternates selected by the City. If the City determines that the unit price for any item is materially different for the work item bid than either other bidders or the general market, the City, in its sole discretion, in addition to any other right it may have, may reject the bid as not responsible or non-conforming.

The acceptability of major subcontractors will be considered in determining if a Bidder is responsible. In comparing Bids, the City will give consideration to alternate Bids for items listed in the bid forms. All key staff and subcontractors are subject to the approval by the City.

## Official Documents

The City of Ann Arbor officially distributes bid documents from the Procurement Unit or through the Michigan Intergovernmental Trade Network (MITN). Copies of the bid documents obtained from any other source are not Official copies. Addenda and other bid information will only be posted to these official distribution sites. If you obtained City of Ann Arbor Bid documents from other sources, it is recommended that you register on [www.MITN.info](http://www.MITN.info) and obtain an official Bid. Bidders do not need to be shown on the plan holders list provided by MITN to be considered an official plan holder.

## Bid Security

Each bid must be accompanied by a certified check, or Bid Bond by a surety licensed and authorized to do business within the State of Michigan, in the amount of 5% of the total of the bid price.

## Withdrawal of Bids

After the time of opening, no Bid may be withdrawn for the period of **ninety (90)** days

## Contract Time

Time is of the essence in the performance of the work under this Contract. The available time for work under this Contract is indicated on page C-1, Article III of the Contract. If these time requirements can not be met, the Bidder must stipulate on Bid Form Section 3 - Time Alternate its schedule for performance of the work. Consideration will be given to time in evaluating bids.

## Liquidated Damages

A liquidated damages clause, as given on page C-2, Article III of the Contract, provides that the Contractor shall pay the City as liquidated damages, and not as a penalty, a sum certain per day for each and every day that the Contractor may be in default of completion of the specified work, within the time(s) stated in the Contract, or written extensions.

Liquidated damages clauses, as given in the General Conditions, provide further that the City shall be entitled to impose and recover liquidated damages for breach of the obligations under Chapter 112 of the City Code.

The liquidated damages are for the non-quantifiable aspects of any of the previously identified events and do not cover actual damages that can be shown or quantified nor are they intended to preclude recovery of actual damages in addition to the recovery of liquidated damages.

## Human Rights Information

All contractors proposing to do business with the City shall satisfy the contract compliance administrative policy adopted by the City Administrator in accordance with the Section 9:158 of the Ann Arbor City Code. Breach of the obligation not to discriminate as outlined in Section 5, beginning at page GC-2 shall be a material breach of the contract. Contractors are required to post a copy of Ann Arbor's Non-Discrimination Ordinance attached at all work locations where its employees provide services under a contract with the City.



## Wage Requirements

Section 4, beginning at page GC-1, outlines the requirements for payment of prevailing wages and for payment of a “living wage” to employees providing service to the City under this contract. The successful bidder and its subcontractors must comply with all applicable requirements and provide proof of compliance.

Pursuant to Resolution R-16-469 all public improvement contractors are subject to prevailing wage and will be required to provide to the City payroll records sufficient to demonstrate compliance with the prevailing wage requirements. Use of the Prevailing Wage Form provided in the Appendix section or a City-approved equivalent will be required along with wage rate interviews.

For laborers whose wage level are subject to federal, state and/or local prevailing wage law the appropriate Davis-Bacon wage rate classification is identified based upon the work including within this contract. **The wage determination(s) current on the date 10 days before bids are due shall apply to this contract.** The U.S. Department of Labor (DOL) has provided explanations to assist with classification in the following resource link: [beta.SAM.gov](http://beta.SAM.gov).

For the purposes of this ITB the Construction Type of Heavy and Highway will apply.

## Conflict Of Interest Disclosure

The City of Ann Arbor Purchasing Policy requires that prospective Vendors complete a Conflict of Interest Disclosure form. A contract may not be awarded to the selected Vendor unless and until the Procurement Unit and the City Administrator have reviewed the Disclosure form and determined that no conflict exists under applicable federal, state, or local law or administrative regulation. Not every relationship or situation disclosed on the Disclosure Form may be a disqualifying conflict. Depending on applicable law and regulations, some contracts may awarded on the recommendation of the City Administrator after full disclosure, where such action is allowed by law, if demonstrated competitive pricing exists and/or it is determined the award is in the best interest of the City. A copy of the Vendor Conflict of Interest Disclosure Form is attached.

## Major Subcontractors

The Bidder shall identify on Bid Form Section 4 each major subcontractor it expects to engage for this Contract if the work to be subcontracted is 15% or more of the bid sum or over \$50,000, whichever is less. The Bidder also shall identify the work to be subcontracted to each major subcontractor. The Bidder shall not change or replace a subcontractor without approval by the City.

## Debarment

Submission of a Bid in response to this ITB is certification that the Bidder is not currently debarred, suspended, proposed for debarment, and declared ineligible or voluntarily excluded from participation in this transaction by any State or Federal departments or agency. Submission is also agreement that the City will be notified of any changes in this status.

## Disclosures

After bids are opened, all information in a submitter’s bid is subjected to disclosure under the provisions of Michigan Public Act No. 442 of 1976, as amended (MCL 15.231 et seq.) known as the “Freedom of Information Act.” The Freedom of Information Act also provides for the complete disclosure of contracts and attachments thereto except where specifically exempted.

## Bid Protest

All Bid protests must be in writing and filed with the Purchasing Agent within five (5) business days of the award action. The bidder must clearly state the reasons for the protest. If a bidder contacts a City Service Area/Unit and indicates a desire to protest an award, the Service Area/Unit shall refer the bidder to the Purchasing Agent. The Purchasing Agent will provide the bidder with the appropriate instructions for filing the protest. The protest shall be reviewed by the City Administrator or designee whose decision shall be final.

*Any inquiries or requests regarding this procurement should be only submitted in writing to the Designated City Contacts provided herein. Attempts by any prospective bidder to initiate contact with anyone other than the Designated City Contacts provided herein that the bidder believes can influence the procurement decision, e.g., Elected Officials, City Administrator, Selection Committee Members, Appointed Committee Members, etc., may lead to immediate elimination from further consideration.*

## Cost Liability

The City of Ann Arbor assumes no responsibility or liability for costs incurred by the Bidder prior to the execution of a contract with the City. By submitting a bid, a bidder agrees to bear all costs incurred or related to the preparation, submission and selection process for the bid.

## Reservation of Rights

The City of Ann Arbor reserves the right to accept any bid or alternative bid proposed in whole or in part, to reject any or all bids or alternatives bids in whole or in part and to waive irregularity and/or informalities in any bid and to make the award in any manner deemed in the best interest of the City.

## Idlefree Ordinance

The City of Ann Arbor adopted an idling reduction Ordinance that goes into effect July 1, 2017. The full text of the ordinance (including exemptions) can be found at: [www.a2gov.org/idlefree](http://www.a2gov.org/idlefree).

Under the ordinance, No Operator of a Commercial Vehicle shall cause or permit the Commercial Vehicle to Idle:

- (a) For any period of time while the Commercial Vehicle is unoccupied; or
- (b) For more than 5 minutes in any 60-minute period while the Commercial Vehicle is occupied.

In addition, generators and other internal combustion engines are covered

(1) Excluding Motor Vehicle engines, no internal combustion engine shall be operated except when it is providing power or electrical energy to equipment or a tool that is actively in use.

## Environmental Commitment

The City of Ann Arbor recognizes its responsibility to minimize negative impacts on human health and the environment while supporting a vibrant community and economy. The City further recognizes that the products and services the City buys have inherent environmental and economic impacts and that the City should make procurement decisions that embody, promote, and encourage the City's commitment to the environment.

The City encourages potential vendors to bring forward emerging and progressive products and services that are best suited to the City's environmental principles.

# INVITATION TO BID

City of Ann Arbor  
Guy C. Larcom Municipal Building  
Ann Arbor, Michigan 48107

Ladies and Gentlemen:

The undersigned, as Bidder, declares that this Bid is made in good faith, without fraud or collusion with any person or persons bidding on the same Contract; that this Bidder has carefully read and examined the bid documents, including City Nondiscrimination requirements and Declaration of Compliance Form, Living Wage requirements and Declaration of Compliance Form, Prevailing Wage requirements and Declaration of Compliance Form, Vendor Conflict of Interest Form, Notice of Pre-Bid Conference, Instructions to Bidders, Bid, Bid Forms, Contract, Bond Forms, General Conditions, Standard Specifications, Detailed Specifications, all Addenda, and the Plans (if applicable) and understands them. The Bidder declares that it conducted a full investigation at the site and of the work proposed and is fully informed as to the nature of the work and the conditions relating to the work's performance. The Bidder also declares that it has extensive experience in successfully completing projects similar to this one.

The Bidder acknowledges that it has not received or relied upon any representations or warrants of any nature whatsoever from the City of Ann Arbor, its agents or employees, and that this Bid is based solely upon the Bidder's own independent business judgment.

The undersigned proposes to perform all work shown on the plans or described in the bid documents, including any addenda issued, and to furnish all necessary machinery, tools, apparatus, and other means of construction to do all the work, furnish all the materials, and complete the work in strict accordance with all terms of the Contract of which this Bid is one part.

In accordance with these bid documents, and Addenda numbered \_\_\_\_\_, the undersigned, as Bidder, proposes to perform at the sites in and/or around Ann Arbor, Michigan, all the work included herein for the amounts set forth in the Bid Forms.

The Bidder declares that it has become fully familiar with the liquidated damage clauses for completion times and for compliance with City Code Chapter 112, understands and agrees that the liquidated damages are for the non-quantifiable aspects of non-compliance and do not cover actual damages that may be shown and agrees that if awarded the Contract, all liquidated damage clauses form part of the Contract.

The Bidder declares that it has become fully familiar with the provisions of Chapter 14, Section 1:320 (Prevailing wages) and Chapter 23 (Living Wage) of the Code of the City of Ann Arbor and that it understands and agrees to comply, to the extent applicable to employees providing services to the City under this Contract, with the wage and reporting requirements stated in the City Code provisions cited. Bidder certifies that the statements contained in the City Prevailing Wage and Living Wage Declaration of Compliance Forms are true and correct. Bidder further agrees that the cited provisions of Chapter 14 and Chapter 23 form a part of this Contract.

The Bidder declares that it has become familiar with the City Conflict of Interest Disclosure Form and certifies that the statement contained therein is true and correct.

The Bidder encloses a certified check or Bid Bond in the amount of 5% of the total of the Bid Price. The Bidder agrees both to contract for the work and to furnish the necessary Bonds and insurance documentation within 10 days after being notified of the acceptance of the Bid.

If this Bid is accepted by the City and the Bidder fails to contract and furnish the required Bonds and insurance documentation within 10 days after being notified of the acceptance of this Bid, then the Bidder shall be considered to have abandoned the Contract and the certified check or Bid Bond accompanying this Bid shall become due and payable to the City.

If the Bidder enters into the Contract in accordance with this Bid, or if this Bid is rejected, then the accompanying check or Bid Bond shall be returned to the Bidder.

In submitting this Bid, it is understood that the right is reserved by the City to accept any Bid, to reject any or all Bids, to waive irregularities and/or informalities in any Bid, and to make the award in any manner the City believes to be in its best interest.

SIGNED THIS \_\_\_\_\_ DAY OF \_\_\_\_\_, 202\_.

\_\_\_\_\_  
Bidder's Name

\_\_\_\_\_  
Authorized Signature of Bidder

\_\_\_\_\_  
Official Address

\_\_\_\_\_  
(Print Name of Signer Above)

\_\_\_\_\_  
Telephone Number

\_\_\_\_\_  
Email Address for Award Notice

**LEGAL STATUS OF BIDDER**

(The Bidder shall fill out the appropriate form and strike out the other three.)

Bidder declares that it is:

\* A corporation organized and doing business under the laws of the State of \_\_\_\_\_, for whom \_\_\_\_\_, bearing the office title of \_\_\_\_\_, whose signature is affixed to this Bid, is authorized to execute contracts.

**NOTE: If not incorporated in Michigan, please attach the corporation's Certificate of Authority**

• A limited liability company doing business under the laws of the State of \_\_\_\_\_, whom \_\_\_\_\_ bearing the title of \_\_\_\_\_ whose signature is affixed to this proposal, is authorized to execute contract on behalf of the LLC.

\* A partnership, organized under the laws of the state of \_\_\_\_\_ and filed in the county of \_\_\_\_\_, whose members are (list all members and the street and mailing address of each) (attach separate sheet if necessary):

\_\_\_\_\_  
\_\_\_\_\_  
\_\_\_\_\_  
\_\_\_\_\_

\* An individual, whose signature with address, is affixed to this Bid: \_\_\_\_\_ (initial here)

**Authorized Official**

\_\_\_\_\_ **Date** \_\_\_\_\_, 202\_

(Print) Name \_\_\_\_\_ Title \_\_\_\_\_

Company: \_\_\_\_\_

Address: \_\_\_\_\_

Contact Phone ( ) \_\_\_\_\_ Fax ( ) \_\_\_\_\_

Email \_\_\_\_\_

THIS PAGE LEFT BLANK ON PRUPOSE

**BID FORM**

**Company**

---

**Project: Barton Drive Water Main Replacement and Resurfacing Project**

**File # 2019-005 Bid # 4617**

<u>Item</u>	<u>Description</u>	<u>Unit</u>	<u>Estimated Quantity</u>	<u>Unit Price</u>	<u>Total Price</u>
130	Protective Fencing	FT	1000	\$ _____	\$ _____
140	Exploratory Excavation (0-10' deep)	EA	4	\$ _____	\$ _____
201	Project Supervision, Max \$15,000.00	LS	1	\$ _____	\$ _____
202	General Conditions, Max. \$30,000.00	LS	1	\$ _____	\$ _____
203	Digital Audio Visual Coverage	LS	1	\$ _____	\$ _____
204	Minor Traffic Devices, Max \$20,000.00	LS	1	\$ _____	\$ _____
205	Clean-Up & Restoration, Special, Max \$10,000	LS	1	\$ _____	\$ _____
206	"No Parking" Signs	EA	40	\$ _____	\$ _____
207	Stump Removal, 8" or Larger, Modified	EA	5	\$ _____	\$ _____
208	Tree Trimming	EA	1	\$ _____	\$ _____
210	Remove Concrete Curb or Curb and Gutter - Any Type	FT	2750	\$ _____	\$ _____
211	Remove Concrete Sidewalk and Drive - Any Thickness	SFT	5200	\$ _____	\$ _____
212	Cold Milling HMA Surface	SYD	2250	\$ _____	\$ _____
213	HMA Surface Remove	SFT	4300	\$ _____	\$ _____
214	Sidewalk Grading	STA	24	\$ _____	\$ _____
215	Sidewalk Ramp Grading	EA	19	\$ _____	\$ _____
216	Sewer, Any Size or Depth, Remove	FT	380	\$ _____	\$ _____
217	Drainage Structure, Any Size or Depth, Remove	EA	22	\$ _____	\$ _____
218	Additional Depth Structure Adjust/Repair	FT	2	\$ _____	\$ _____
219	Guardrail, Rem	FT	530	\$ _____	\$ _____
220	Remove Sanitary Sewer Lead	FT	20	\$ _____	\$ _____
221	Water Main Pipe Abandonment, Modified	LS	1	\$ _____	\$ _____
222	Fire Hydrant Assembly Abandonment	EA	1	\$ _____	\$ _____
223	Temporary Water Main Line Stop, Additional Rental Day	EA	4	\$ _____	\$ _____
224	Temporary Water Main Line Stop, Less than 8 inch	EA	2	\$ _____	\$ _____
225	Temporary 8 inch or 12 inch Water Main Line Stop	EA	2	\$ _____	\$ _____

TOTAL THIS PAGE (BF-1) \$ \_\_\_\_\_  
 (Also to be entered on Page BF-4)

230	Machine Grading, Modified	SYD	22400	\$ _____	\$ _____
231	Subgrade Undercutting - Type II	CYD	100	\$ _____	\$ _____
232	Sand Subbase Course, Class II - C.I.P.	CYD	1400	\$ _____	\$ _____
233	21AA Limestone, C.I.P.	CYD	100	\$ _____	\$ _____
234	Aggregate Base Course, 21AA - C.I.P.	TON	1500	\$ _____	\$ _____
237	HMA Pavement Leveling/Top – LVSP	TON	2600	\$ _____	\$ _____
238	HMA Approach	TON	30	\$ _____	\$ _____
239	Handpatching	TON	45	\$ _____	\$ _____
240	Concrete Curb or Curb and Gutter - All Types	FT	1850	\$ _____	\$ _____
241	Concrete Curb or Curb and Gutter - All Types (High Early)	FT	400	\$ _____	\$ _____
242	4 Inch Concrete Sidewalk	SFT	7700	\$ _____	\$ _____
243	6 Inch Concrete Sidewalk or Sidewalk Ramp	SFT	1600	\$ _____	\$ _____
244	6 Inch Concrete Drive - High Early	SFT	3100	\$ _____	\$ _____
245	Detectable Warning, Cast In Place	SFT	200	\$ _____	\$ _____
246	Integral Sidewalk Retaining Wall, under 6 inch	SFT	20	\$ _____	\$ _____
247	Integral Sidewalk Retaining Wall, 6 inch to 18 inch	SFT	70	\$ _____	\$ _____
248	Integral Sidewalk Retaining Wall, 19 inch to 36 inch	SFT	20	\$ _____	\$ _____
250	Pavt Mrkg, Ovly Cold Plastic, 12 inch, Crosswalk	FT	710	\$ _____	\$ _____
251	Pavt Mrkg, Ovly Cold Plastic, 24 inch, Stop Bar	FT	50	\$ _____	\$ _____
252	Pavt Mrkg, Ovly Cold Plastic, Direction Arrow Sym, Bike	EA	3	\$ _____	\$ _____
253	Pavt Mrkg, Ovly Cold Plastic, Bike, Small Sym	EA	3	\$ _____	\$ _____
254	Pavt Mrkg, Ovly Cold Plastic, Sharrow Symbol	EA	4	\$ _____	\$ _____
255	Pavt Mrkg, Polyurea, 4 inch, White	FT	1500	\$ _____	\$ _____
256	Pavt Mrkg, Polyurea, 4 inch, Yellow	FT	6050	\$ _____	\$ _____
257	Pavt Mrkg, Polyurea, 6 inch, White	FT	2400	\$ _____	\$ _____
258	Recessing Pavt Mrkg, Longit	FT	9950	\$ _____	\$ _____
260	Pavt Mrg Cover, Type R, Black	FT	1725	\$ _____	\$ _____
261	Pavt Mrkg, Wet Reflective, Type R, Tape, 4 inch, White, Temp	FT	500	\$ _____	\$ _____
262	Pavt Mrkg, Wet Reflective, Type R, Tape, 4 inch, Yellow, Temp	FT	1100	\$ _____	\$ _____
263	Pavt Mrkg, Wet Reflective, Type R, Tape, 6 inch Crosswalk	FT	50	\$ _____	\$ _____
264	Pavt Mrkg, Wet Reflective, Type R, Tape, 24 inch Stop Bar	FT	11	\$ _____	\$ _____
265	Temporary Curb for Bump-out	FT	50	\$ _____	\$ _____

TOTAL THIS PAGE (BF-2) \$ \_\_\_\_\_  
(Also to be entered on page BF-4)



266	Sign, Portable Changeable Message, Furnish and Operate	EA	4	\$ _____	\$ _____
267	Plastic Drum - Lighted, Furnish and Operate	EA	270	\$ _____	\$ _____
268	Barricade Type III - Lighted, Furnish and Operate	EA	35	\$ _____	\$ _____
269	Temporary Sign, Type B, Furnish and Operate	SFT	1000	\$ _____	\$ _____
270	Temporary Sign, Type B, Furnish and Operate, Special	SFT	132	\$ _____	\$ _____
271	Channelizing Device, 42 Inch, Furnish and Operate	EA	50	\$ _____	\$ _____
272	Pedestrian Type II Barricade, Temp	EA	32	\$ _____	\$ _____
273	Sign Cover	EA	10	\$ _____	\$ _____
274	Temporary Pedestrian Ramp	EA	2	\$ _____	\$ _____
275	Temporary Pedestrian Mat	EA	50	\$ _____	\$ _____
276	Audible Message Device	EA	4	\$ _____	\$ _____
280	Fertilizer, Chemical Nutrient, CI A	LBS	90	\$ _____	\$ _____
281	Mulch Blanket, High Velocity	SYD	2150	\$ _____	\$ _____
282	Seeding, Mixture THM	LBS	100	\$ _____	\$ _____
283	Topsoil Surface, Furn, 4 inch	SYD	2150	\$ _____	\$ _____
284	Fire Hydrant Assembly	EA	1	\$ _____	\$ _____
285	Underground Sprinkling Systems, Restore	DLR	3000	\$ _____	\$ _____
290	Certified Payroll Compliance and Reporting	LS	1	\$ _____	\$ _____
295	6-Inch Wrapped Underdrain	FT	2150	\$ _____	\$ _____
320	12" CL IV RCP Storm Sewer Pipe, Trench Detail I	FT	440	\$ _____	\$ _____
353	4 inch SDR 35 PVC Sanitary Lead, Trench Detail I	FT	10	\$ _____	\$ _____
354	6 inch SDR 35 PVC Sanitary Lead, Trench Detail I	FT	10	\$ _____	\$ _____
360	Type I Manhole, 60 inch Dia )-10' deep)	EA	1	\$ _____	\$ _____
366	Inlet-Junction Chamber	EA	3	\$ _____	\$ _____
367	Single Inlet	EA	20	\$ _____	\$ _____
400	6 inch Class 50 DIP w/polywrap, Trench Detail I	FT	21	\$ _____	\$ _____
401	8 inch Class 50 DIP w/polywrap, Trench Detail I	FT	1030	\$ _____	\$ _____
410	8" 11.25° Bend	EA	8	\$ _____	\$ _____
411	8" 22.5° Bend	EA	2	\$ _____	\$ _____
412	8" 45° Bend	EA	4	\$ _____	\$ _____
413	8" 90° Bend	EA	1	\$ _____	\$ _____
414	8" x 6" Reducer	EA	4	\$ _____	\$ _____

TOTAL THIS PAGE (BF-3) \$ \_\_\_\_\_  
(Also to be entered on BF-4)

430	8" x 8" x 8" Tee	EA	4	\$ _____	\$ _____
431	8" x 8" x 8" x 8" Cross	EA	1	\$ _____	\$ _____
442	8" Gate Valve-in-Box	EA	1	\$ _____	\$ _____
446	6" Gate Valve-in Well	EA	1	\$ _____	\$ _____
447	8" Gate Valve-in Well	EA	3	\$ _____	\$ _____
460	Excavate & Backfill for Water Service Tap and Lead	FT	235	\$ _____	\$ _____
563	Structure Covers	LBS	2400	\$ _____	\$ _____
566	Adjust Structure Cover	EA	21	\$ _____	\$ _____
567	Adjust Monument Box or Gate Valve Box	EA	8	\$ _____	\$ _____
800	Celtic occidentalis, (Hackberry), 2 inch	EA	1	\$ _____	\$ _____
801	Syringa Volgaris (Lilac Bush)	EA	2	\$ _____	\$ _____
802	Acer rubrum, (Red Maple), 2 inch	EA	1	\$ _____	\$ _____
TOTAL THIS PAGE (BF-4)				\$ _____	
TOTAL FROM PAGE BF-1				\$ _____	
TOTAL FROM PAGE BF-2				\$ _____	
TOTAL FROM PAGE BF-3				\$ _____	
<b>TOTAL BASE BID</b>				\$ _____	

# BID FORM

## Section 2 – Material, Equipment and Environmental Alternates

The Base Bid proposal price shall include materials and equipment selected from the designated items and manufacturers listed in the bidding documents. This is done to establish uniformity in bidding and to establish standards of quality for the items named.

If the Contractor wishes to quote alternate items for consideration by the City, it may do so under this Section. A complete description of the item and the proposed price differential must be provided. Unless approved at the time of award, substitutions where items are specifically named will be considered only as a negotiated change in Contract Sum.

If an environmental alternative is bid the City strongly encourages bidders to provide recent examples of product testing and previous successful use for the City to properly evaluate the environmental alternative. Testing data from independent accredited organizations are strongly preferred.

<u>Item Number</u>	<u>Description</u>	<u>Add/Deduct Amount</u>
--------------------	--------------------	--------------------------

If the Bidder does not suggest any material or equipment alternate, the Bidder **MUST** complete the following statement:

For the work outlined in this request for bid, the bidder does NOT propose any material or equipment alternate under the Contract.

Signature of Authorized Representative of Bidder \_\_\_\_\_ Date \_\_\_\_\_

# BID FORM

## Section 3 - Time Alternate

If the Bidder takes exception to the time stipulated in Article III of the Contract, Time of Completion, page C-2, it is requested to stipulate below its proposed time for performance of the work. Consideration will be given to time in evaluating bids.

If the Bidder does not suggest any time alternate, the Bidder **MUST** complete the following statement:

For the work outlined in this request for bid, the bidder does NOT propose any time alternate under the Contract.

Signature of Authorized Representative of Bidder \_\_\_\_\_ Date \_\_\_\_\_

# BID FORM

## Section 4 - Major Subcontractors

For purposes of this Contract, a Subcontractor is anyone (other than the Contractor) who performs work (other than or in addition to the furnishing of materials, plans or equipment) at or about the construction site, directly or indirectly for or on behalf of the Contractor (and whether or not in privity of Contract with the Contractor), but shall not include any individual who furnishes merely the individual's own personal labor or services.

Contractor agrees that all subcontracts entered into by the Contractor shall contain similar wage provision to Section 4 of the General Conditions covering subcontractor's employees who perform work on this contract.

For the work outlined in these documents the Bidder expects to engage the following major subcontractors to perform the work identified:

Subcontractor (Name and Address)	Work	Amount
----------------------------------	------	--------

If the Bidder does not expect to engage any major subcontractor, the Bidder **MUST** complete the following statement:

For the work outlined in this request for bid, the bidder does NOT expect to engage any major subcontractor to perform work under the Contract.

Signature of Authorized Representative of Bidder \_\_\_\_\_ Date \_\_\_\_\_

# BID FORM

## Section 5 – References

Include a minimum of three (3) reference from similar project completed within the past two (2) years.

**[Refer also to Instructions to Bidders for additional requirements, if any]**

1) \_\_\_\_\_  
Project Name                      Cost                      Date Constructed

\_\_\_\_\_                      \_\_\_\_\_  
Contact Name                      Phone Number

2) \_\_\_\_\_  
Project Name                      Cost                      Date Constructed

\_\_\_\_\_                      \_\_\_\_\_  
Contact Name                      Phone Number

3) \_\_\_\_\_  
Project Name                      Cost                      Date Constructed

\_\_\_\_\_                      \_\_\_\_\_  
Contact Name                      Phone Number

# CONTRACT

THIS AGREEMENT is made on the \_\_\_\_\_ day of \_\_\_\_\_, 201\_, between the CITY OF ANN ARBOR, a Michigan Municipal Corporation, 301 East Huron Street, Ann Arbor, Michigan 48104 ("City") and \_\_\_\_\_ ("Contractor")

(An individual/partnership/corporation, include state of incorporation)

(Address)

Based upon the mutual promises below, the Contractor and the City agree as follows:

## ARTICLE I - Scope of Work

The Contractor agrees to furnish all of the materials, equipment and labor necessary; and to abide by all the duties and responsibilities applicable to it for the project titled [Insert Title of Bid and Bid Number] in accordance with the requirements and provisions of the following documents, including all written modifications incorporated into any of the documents, which are incorporated as part of this Contract:

Non-discrimination and Living Wage Declaration of Compliance Forms (if applicable)	General Conditions
Vendor Conflict of Interest Form	Standard Specifications
Prevailing Wage Declaration of Compliance Form (if applicable)	Detailed Specifications
Bid Forms	Plans
Contract and Exhibits	Addenda
Bonds	

## ARTICLE II - Definitions

Administering Service Area/Unit means **Public Services / Engineering Unit**

Project means **ITB 4617 Barton Drive Water Main Replacement and Resurfacing Project**

## ARTICLE III - Time of Completion

- (A) The work to be completed under this Contract shall begin immediately on the date specified in the Notice to Proceed issued by the City.
- (B) The entire work for this Contract shall be completed within **one-hundred forty-two (142)** consecutive calendar days.
- (C) Failure to complete all the work within the time specified above, including any extension granted in writing by the Supervising Professional, shall obligate the Contractor to pay the City, as liquidated damages and not as a penalty, an amount equal to **\$400** for each calendar day of delay in the completion of all the work. If any liquidated damages are unpaid by the Contractor, the City shall be entitled to deduct these unpaid liquidated damages from the monies due the Contractor.

The liquidated damages are for the non-quantifiable aspects of any of the previously identified events and do not cover actual damages that can be shown or quantified nor are they intended to preclude recovery of actual damages in addition to the recovery of liquidated damages.

**ARTICLE IV - The Contract Sum**

- (A) The City shall pay to the Contractor for the performance of the Contract, the unit prices as given in the Bid Form for the estimated bid total of:

\_\_\_\_\_ Dollars (\$\_\_\_\_\_)

- (B) The amount paid shall be equitably adjusted to cover changes in the work ordered by the Supervising Professional but not required by the Contract Documents. Increases or decreases shall be determined only by written agreement between the City and Contractor.

**ARTICLE V - Assignment**

This Contract may not be assigned or subcontracted any portion of any right or obligation under this contract without the written consent of the City. Notwithstanding any consent by the City to any assignment, Contractor shall at all times remain bound to all warranties, certifications, indemnifications, promises and performances, however described, as are required of it under this contract unless specifically released from the requirement, in writing, by the City.

**ARTICLE VI - Choice of Law**

This Contract shall be construed, governed, and enforced in accordance with the laws of the State of Michigan. By executing this agreement, the Contractor and the City agree to venue in a court of appropriate jurisdiction sitting within Washtenaw County for purposes of any action arising under this Contract. The parties stipulate that the venue referenced in this Contract is for convenience and waive any claim of non-convenience.

Whenever possible, each provision of the Contract will be interpreted in a manner as to be effective and valid under applicable law. The prohibition or invalidity, under applicable law, of any provision will not invalidate the remainder of the Contract.

**ARTICLE VII - Relationship of the Parties**

The parties of the Contract agree that it is not a Contract of employment but is a Contract to accomplish a specific result. Contractor is an independent Contractor performing services for the City. Nothing contained in this Contract shall be deemed to constitute any other relationship between the City and the Contractor.

Contractor certifies that it has no personal or financial interest in the project other than the compensation it is to receive under the Contract. Contractor certifies that it is not, and shall not become, overdue or in default to the City for any Contract, debt, or any other obligation to the City including real or personal property taxes. City shall have the right to set off any such debt against compensation awarded for services under this agreement.

**ARTICLE VIII - Notice**

All notices given under this Contract shall be in writing, and shall be by personal delivery or by certified mail with return receipt requested to the parties at their respective addresses as specified in the Contract Documents or other address the Contractor may specify in writing. Notice will be deemed given on the date when one of the following first occur: (1) the date of actual receipt; or (2) three days after mailing certified U.S. mail.



**ARTICLE IX - Indemnification**

To the fullest extent permitted by law, Contractor shall indemnify, defend and hold the City, its officers, employees and agents harmless from all suits, claims, judgments and expenses including attorney’s fees resulting or alleged to result, in whole or in part, from any act or omission, which is in any way connected or associated with this Contract, by the Contractor or anyone acting on the Contractor’s behalf under this Contract. Contractor shall not be responsible to indemnify the City for losses or damages caused by or resulting from the City’s sole negligence. The provisions of this Article shall survive the expiration or earlier termination of this contract for any reason.

**ARTICLE X - Entire Agreement**

This Contract represents the entire understanding between the City and the Contractor and it supersedes all prior representations, negotiations, agreements, or understandings whether written or oral. Neither party has relied on any prior representations in entering into this Contract. No terms or conditions of either party’s invoice, purchase order or other administrative document shall modify the terms and conditions of this Contract, regardless of the other party’s failure to object to such form. This Contract shall be binding on and shall inure to the benefit of the parties to this Contract and their permitted successors and permitted assigns and nothing in this Contract, express or implied, is intended to or shall confer on any other person or entity any legal or equitable right, benefit, or remedy of any nature whatsoever under or by reason of this Contract. This Contract may be altered, amended or modified only by written amendment signed by the City and the Contractor.

**FOR CONTRACTOR**

By \_\_\_\_\_

Its: \_\_\_\_\_

**FOR THE CITY OF ANN ARBOR**

By \_\_\_\_\_  
Christopher Taylor, Mayor

By \_\_\_\_\_  
Jacqueline Beaudry, City Clerk

**Approved as to substance**

By \_\_\_\_\_  
City Administrator

By \_\_\_\_\_  
Craig Hupy  
Public Services Area Administrator

**Approved as to form and content**

\_\_\_\_\_  
Stephen K. Postema, City Attorney

THE PAGE LEFT BLANK ON PURPOSE

**PERFORMANCE BOND**

(1) \_\_\_\_\_ of \_\_\_\_\_ (referred to as "Principal"), and \_\_\_\_\_, a corporation duly authorized to do business in the State of Michigan (referred to as "Surety"), are bound to the City of Ann Arbor, Michigan (referred to as "City"), for

\$ \_\_\_\_\_, the payment of which Principal and Surety bind themselves, their heirs, executors, administrators, successors and assigns, jointly and severally, by this bond.

(2) The Principal has entered a written Contract with the City dated \_\_\_\_\_, 202\_\_, for: \_\_\_\_\_ and this bond is given for that Contract in compliance with Act No. 213 of the Michigan Public Acts of 1963, as amended, being MCL 129.201 et seq.

(3) Whenever the Principal is declared by the City to be in default under the Contract, the Surety may promptly remedy the default or shall promptly:

(a) complete the Contract in accordance with its terms and conditions; or

(b) obtain a bid or bids for submission to the City for completing the Contract in accordance with its terms and conditions, and upon determination by Surety of the lowest responsible bidder, arrange for a Contract between such bidder and the City, and make available, as work progresses, sufficient funds to pay the cost of completion less the balance of the Contract price; but not exceeding, including other costs and damages for which Surety may be liable hereunder, the amount set forth in paragraph 1.

(4) Surety shall have no obligation to the City if the Principal fully and promptly performs under the Contract.

(5) Surety agrees that no change, extension of time, alteration or addition to the terms of the Contract or to the work to be performed thereunder, or the specifications accompanying it shall in any way affect its obligations on this bond, and waives notice of any such change, extension of time, alteration or addition to the terms of the Contract or to the work, or to the specifications.

**SIGNED AND SEALED** this \_\_\_\_\_ day of \_\_\_\_\_, 202\_\_.

\_\_\_\_\_  
(Name of Surety Company)

By \_\_\_\_\_  
(Signature)

Its \_\_\_\_\_  
(Title of Office)

Approved as to form:

\_\_\_\_\_  
Stephen K. Postema, City Attorney

\_\_\_\_\_  
(Name of Principal)

By \_\_\_\_\_  
(Signature)

Its \_\_\_\_\_  
(Title of Office)

Name and address of agent:

\_\_\_\_\_  
\_\_\_\_\_  
\_\_\_\_\_

THIS PAGE LEFT BLANK ON PURPOSE

**LABOR AND MATERIAL BOND**

- (1) \_\_\_\_\_  
of \_\_\_\_\_ (referred to as "Principal"), and \_\_\_\_\_, a corporation duly authorized to do business in the State of Michigan, (referred to as "Surety"), are bound to the City of Ann Arbor, Michigan (referred to as "City"), for the use and benefit of claimants as defined in Act 213 of Michigan Public Acts of 1963, as amended, being MCL 129.201 et seq., in the amount of \$ \_\_\_\_\_, for the payment of which Principal and Surety bind themselves, their heirs, executors, administrators, successors and assigns, jointly and severally, by this bond.
- (2) The Principal has entered a written Contract with the City, dated \_\_\_\_\_, 202\_, for \_\_\_\_\_; and this bond is given for that Contract in compliance with Act No. 213 of the Michigan Public Acts of 1963 as amended;
- (3) If the Principal fails to promptly and fully repay claimants for labor and material reasonably required under the Contract, the Surety shall pay those claimants.
- (4) Surety's obligations shall not exceed the amount stated in paragraph 1, and Surety shall have no obligation if the Principal promptly and fully pays the claimants.

**SIGNED AND SEALED** this \_\_\_\_\_ day of \_\_\_\_\_, 202\_

\_\_\_\_\_  
(Name of Surety Company)

By \_\_\_\_\_  
(Signature)

Its \_\_\_\_\_  
(Title of Office)

Approved as to form:

\_\_\_\_\_  
Stephen K. Postema, City Attorney

\_\_\_\_\_  
(Name of Principal)

By \_\_\_\_\_  
(Signature)

Its \_\_\_\_\_  
(Title of Office)

Name and address of agent:

\_\_\_\_\_  
\_\_\_\_\_  
\_\_\_\_\_

THIS PAGE LEFT BLANK ON PURPOSE

# **GENERAL CONDITIONS**

## **Section 1 - Execution, Correlation and Intent of Documents**

The contract documents shall be signed in 2 copies by the City and the Contractor.

The contract documents are complementary and what is called for by any one shall be binding. The intention of the documents is to include all labor and materials, equipment and transportation necessary for the proper execution of the work. Materials or work described in words which so applied have a well-known technical or trade meaning have the meaning of those recognized standards.

In case of a conflict among the contract documents listed below in any requirement(s), the requirement(s) of the document listed first shall prevail over any conflicting requirement(s) of a document listed later.

(1) Addenda in reverse chronological order; (2) Detailed Specifications; (3) Standard Specifications; (4) Plans; (5) General Conditions; (6) Contract; (7) Bid Forms; (8) Bond Forms; (9) Bid.

## **Section 2 - Order of Completion**

The Contractor shall submit with each invoice, and at other times reasonably requested by the Supervising Professional, schedules showing the order in which the Contractor proposes to carry on the work. They shall include the dates at which the Contractor will start the several parts of the work, the estimated dates of completion of the several parts, and important milestones within the several parts.

## **Section 3 - Familiarity with Work**

The Bidder or its representative shall make personal investigations of the site of the work and of existing structures and shall determine to its own satisfaction the conditions to be encountered, the nature of the ground, the difficulties involved, and all other factors affecting the work proposed under this Contract. The Bidder to whom this Contract is awarded will not be entitled to any additional compensation unless conditions are clearly different from those which could reasonably have been anticipated by a person making diligent and thorough investigation of the site.

The Bidder shall immediately notify the City upon discovery, and in every case prior to submitting its Bid, of every error or omission in the bidding documents that would be identified by a reasonably competent, diligent Bidder. In no case will a Bidder be allowed the benefit of extra compensation or time to complete the work under this Contract for extra expenses or time spent as a result of the error or omission.

## **Section 4 - Wage Requirements**

Under this Contract, the Contractor shall conform to Chapter 14 of Title I of the Code of the City of Ann Arbor as amended; which in part states "...that all craftsmen, mechanics and laborers employed directly on the site in connection with said improvements, including said employees of subcontractors, shall receive the prevailing wage for the corresponding classes of craftsmen,

mechanics and laborers, as determined by statistics for the Ann Arbor area compiled by the United States Department of Labor. At the request of the City, any contractor or subcontractor shall provide satisfactory proof of compliance with the contract provisions required by the Section.

Pursuant to Resolution R-16-469 all public improvement contractors are subject to prevailing wage and will be required to provide to the City payroll records sufficient to demonstrate compliance with the prevailing wage requirements. A sample Prevailing Wage Form is provided in the Appendix herein for reference as to what will be expected from contractors. Use of the Prevailing Wage Form provided in the Appendix section or a City-approved equivalent will be required along with wage rate interviews.

Where the Contract and the Ann Arbor City Ordinance are silent as to definitions of terms required in determining contract compliance with regard to prevailing wages, the definitions provided in the Davis-Bacon Act as amended (40 U.S.C. 278-a to 276-a-7) for the terms shall be used.

If the Contractor is a "covered employer" as defined in Chapter 23 of the Ann Arbor City Code, the Contractor agrees to comply with the living wage provisions of Chapter 23 of the Ann Arbor City Code. The Contractor agrees to pay those employees providing Services to the City under this Agreement a "living wage," as defined in Section 1:815 of the Ann Arbor City Code, as adjusted in accordance with Section 1:815(3); to post a notice approved by the City of the applicability of Chapter 23 in every location in which regular or contract employees providing services under this Agreement are working; to maintain records of compliance; if requested by the City, to provide documentation to verify compliance; to take no action that would reduce the compensation, wages, fringe benefits, or leave available to any employee or person contracted for employment in order to pay the living wage required by Section 1:815; and otherwise to comply with the requirements of Chapter 23.

Contractor agrees that all subcontracts entered into by the Contractor shall contain similar wage provision covering subcontractor's employees who perform work on this contract.

## **Section 5 - Non-Discrimination**

The Contractor agrees to comply, and to require its subcontractor(s) to comply, with the nondiscrimination provisions of MCL 37.2209. The Contractor further agrees to comply with the provisions of Section 9:158 of Chapter 112 of Title IX of the Ann Arbor City Code, and to assure that applicants are employed and that employees are treated during employment in a manner which provides equal employment opportunity.

## **Section 6 - Materials, Appliances, Employees**

Unless otherwise stipulated, the Contractor shall provide and pay for all materials, labor, water, tools, equipment, light, power, transportation, and other facilities necessary or used for the execution and completion of the work. Unless otherwise specified, all materials incorporated in the permanent work shall be new, and both workmanship and materials shall be of the highest quality. The Contractor shall, if required, furnish satisfactory evidence as to the kind and quality of materials.

The Contractor shall at all times enforce strict discipline and good order among its employees, and shall seek to avoid employing on the work any unfit person or anyone not skilled in the work assigned.

Adequate sanitary facilities shall be provided by the Contractor.



## **Section 7 - Qualifications for Employment**

The Contractor shall employ competent laborers and mechanics for the work under this Contract. For work performed under this Contract, employment preference shall be given to qualified local residents.

## **Section 8 - Royalties and Patents**

The Contractor shall pay all royalties and license fees. It shall defend all suits or claims for infringements of any patent rights and shall hold the City harmless from loss on account of infringement except that the City shall be responsible for all infringement loss when a particular process or the product of a particular manufacturer or manufacturers is specified, unless the City has notified the Contractor prior to the signing of the Contract that the particular process or product is patented or is believed to be patented.

## **Section 9 - Permits and Regulations**

The Contractor must secure and pay for all permits, permit or plan review fees and licenses necessary for the prosecution of the work. These include but are not limited to City building permits, right-of-way permits, lane closure permits, right-of-way occupancy permits, and the like. The City shall secure and pay for easements shown on the plans unless otherwise specified.

The Contractor shall give all notices and comply with all laws, ordinances, rules and regulations bearing on the conduct of the work as drawn and specified. If the Contractor observes that the contract documents are at variance with those requirements, it shall promptly notify the Supervising Professional in writing, and any necessary changes shall be adjusted as provided in the Contract for changes in the work.

## **Section 10 - Protection of the Public and of Work and Property**

The Contractor is responsible for the means, methods, sequences, techniques and procedures of construction and safety programs associated with the work contemplated by this contract. The Contractor, its agents or sub-contractors, shall comply with the "General Rules and Regulations for the Construction Industry" as published by the Construction Safety Commission of the State of Michigan and to all other local, State and National laws, ordinances, rules and regulations pertaining to safety of persons and property.

The Contractor shall take all necessary and reasonable precautions to protect the safety of the public. It shall continuously maintain adequate protection of all work from damage, and shall take all necessary and reasonable precautions to adequately protect all public and private property from injury or loss arising in connection with this Contract. It shall make good any damage, injury or loss to its work and to public and private property resulting from lack of reasonable protective precautions, except as may be due to errors in the contract documents, or caused by agents or employees of the City. The Contractor shall obtain and maintain sufficient insurance to cover damage to any City property at the site by any cause.

In an emergency affecting the safety of life, or the work, or of adjoining property, the Contractor is, without special instructions or authorization from the Supervising Professional, permitted to act at its discretion to prevent the threatened loss or injury. It shall also so act, without appeal, if authorized or instructed by the Supervising Professional.

Any compensation claimed by the Contractor for emergency work shall be determined by agreement or in accordance with the terms of Claims for Extra Cost - Section 15.

## **Section 11 - Inspection of Work**

The City shall provide sufficient competent personnel for the inspection of the work.

The Supervising Professional shall at all times have access to the work whenever it is in preparation or progress, and the Contractor shall provide proper facilities for access and for inspection.

If the specifications, the Supervising Professional's instructions, laws, ordinances, or any public authority require any work to be specially tested or approved, the Contractor shall give the Supervising Professional timely notice of its readiness for inspection, and if the inspection is by an authority other than the Supervising Professional, of the date fixed for the inspection. Inspections by the Supervising Professional shall be made promptly, and where practicable at the source of supply. If any work should be covered up without approval or consent of the Supervising Professional, it must, if required by the Supervising Professional, be uncovered for examination and properly restored at the Contractor's expense.

Re-examination of any work may be ordered by the Supervising Professional, and, if so ordered, the work must be uncovered by the Contractor. If the work is found to be in accordance with the contract documents, the City shall pay the cost of re-examination and replacement. If the work is not in accordance with the contract documents, the Contractor shall pay the cost.

## **Section 12 - Superintendence**

The Contractor shall keep on the work site, during its progress, a competent superintendent and any necessary assistants, all satisfactory to the Supervising Professional. The superintendent will be responsible to perform all on-site project management for the Contractor. The superintendent shall be experienced in the work required for this Contract. The superintendent shall represent the Contractor and all direction given to the superintendent shall be binding as if given to the Contractor. Important directions shall immediately be confirmed in writing to the Contractor. Other directions will be confirmed on written request. The Contractor shall give efficient superintendence to the work, using its best skill and attention.

## **Section 13 - Changes in the Work**

The City may make changes to the quantities of work within the general scope of the Contract at any time by a written order and without notice to the sureties. If the changes add to or deduct from the extent of the work, the Contract Sum shall be adjusted accordingly. All the changes shall be executed under the conditions of the original Contract except that any claim for extension of time caused by the change shall be adjusted at the time of ordering the change.

In giving instructions, the Supervising Professional shall have authority to make minor changes in the work not involving extra cost and not inconsistent with the purposes of the work, but otherwise, except in an emergency endangering life or property, no extra work or change shall be made unless in pursuance of a written order by the Supervising Professional, and no claim for an addition to the Contract Sum shall be valid unless the additional work was ordered in writing.

The Contractor shall proceed with the work as changed and the value of the work shall be determined as provided in Claims for Extra Cost - Section 15.

## **Section 14 - Extension of Time**

Extension of time stipulated in the Contract for completion of the work will be made if and as the

Supervising Professional may deem proper under any of the following circumstances:

- (1) When work under an extra work order is added to the work under this Contract;
- (2) When the work is suspended as provided in Section 20;
- (3) When the work of the Contractor is delayed on account of conditions which could not have been foreseen, or which were beyond the control of the Contractor, and which were not the result of its fault or negligence;
- (4) Delays in the progress of the work caused by any act or neglect of the City or of its employees or by other Contractors employed by the City;
- (5) Delay due to an act of Government;
- (6) Delay by the Supervising Professional in the furnishing of plans and necessary information;
- (7) Other cause which in the opinion of the Supervising Professional entitles the Contractor to an extension of time.

The Contractor shall notify the Supervising Professional within 7 days of an occurrence or conditions which, in the Contractor's opinion, entitle it to an extension of time. The notice shall be in writing and submitted in ample time to permit full investigation and evaluation of the Contractor's claim. The Supervising Professional shall acknowledge receipt of the Contractor's notice within 7 days of its receipt. Failure to timely provide the written notice shall constitute a waiver by the Contractor of any claim.

In situations where an extension of time in contract completion is appropriate under this or any other section of the contract, the Contractor understands and agrees that the only available adjustment for events that cause any delays in contract completion shall be extension of the required time for contract completion and that there shall be no adjustments in the money due the Contractor on account of the delay.

## **Section 15 - Claims for Extra Cost**

If the Contractor claims that any instructions by drawings or other media issued after the date of the Contract involved extra cost under this Contract, it shall give the Supervising Professional written notice within 7 days after the receipt of the instructions, and in any event before proceeding to execute the work, except in emergency endangering life or property. The procedure shall then be as provided for Changes in the Work-Section 13. No claim shall be valid unless so made.

If the Supervising Professional orders, in writing, the performance of any work not covered by the contract documents, and for which no item of work is provided in the Contract, and for which no unit price or lump sum basis can be agreed upon, then the extra work shall be done on a Cost-Plus-Percentage basis of payment as follows:

- (1) The Contractor shall be reimbursed for all reasonable costs incurred in doing the work, and shall receive an additional payment of 15% of all the reasonable costs to cover both its indirect overhead costs and profit;
- (2) The term "Cost" shall cover all payroll charges for employees and supervision required under the specific order, together with all worker's compensation, Social Security, pension and retirement allowances and social insurance, or other regular payroll charges on same;

the cost of all material and supplies required of either temporary or permanent character; rental of all power-driven equipment at agreed upon rates, together with cost of fuel and supply charges for the equipment; and any costs incurred by the Contractor as a direct result of executing the order, if approved by the Supervising Professional;

- (3) If the extra is performed under subcontract, the subcontractor shall be allowed to compute its charges as described above. The Contractor shall be permitted to add an additional charge of 5% percent to that of the subcontractor for the Contractor's supervision and contractual responsibility;
- (4) The quantities and items of work done each day shall be submitted to the Supervising Professional in a satisfactory form on the succeeding day, and shall be approved by the Supervising Professional and the Contractor or adjusted at once;
- (5) Payments of all charges for work under this Section in any one month shall be made along with normal progress payments. Retainage shall be in accordance with Progress Payments-Section 16.

No additional compensation will be provided for additional equipment, materials, personnel, overtime or special charges required to perform the work within the time requirements of the Contract.

When extra work is required and no suitable price for machinery and equipment can be determined in accordance with this Section, the hourly rate paid shall be 1/40 of the basic weekly rate listed in the Rental Rate Blue Book published by Dataquest Incorporated and applicable to the time period the equipment was first used for the extra work. The hourly rate will be deemed to include all costs of operation such as bucket or blade, fuel, maintenance, "regional factors", insurance, taxes, and the like, but not the costs of the operator.

## **Section 16 - Progress Payments**

The Contractor shall submit each month, or at longer intervals, if it so desires, an invoice covering work performed for which it believes payment, under the Contract terms, is due. The submission shall be to the City's Finance Department - Accounting Division. The Supervising Professional will, within 10 days following submission of the invoice, prepare a certificate for payment for the work in an amount to be determined by the Supervising Professional as fairly representing the acceptable work performed during the period covered by the Contractor's invoice. To insure the proper performance of this Contract, the City will retain a percentage of the estimate in accordance with Act 524, Public Acts of 1980. The City will then, following the receipt of the Supervising Professional's Certificate, make payment to the Contractor as soon as feasible, which is anticipated will be within 15 days.

An allowance may be made in progress payments if substantial quantities of permanent material have been delivered to the site but not incorporated in the completed work if the Contractor, in the opinion of the Supervising Professional, is diligently pursuing the work under this Contract. Such materials shall be properly stored and adequately protected. Allowance in the estimate shall be at the invoice price value of the items. Notwithstanding any payment of any allowance, all risk of loss due to vandalism or any damages to the stored materials remains with the Contractor.

In the case of Contracts which include only the Furnishing and Delivering of Equipment, the payments shall be; 60% of the Contract Sum upon the delivery of all equipment to be furnished, or in the case of delivery of a usable portion of the equipment in advance of the total equipment delivery, 60% of the estimated value of the portion of the equipment may be paid upon its delivery in advance of the time of the remainder of the equipment to be furnished; 30% of the Contract

Sum upon completion of erection of all equipment furnished, but not later than 60 days after the date of delivery of all of the equipment to be furnished; and payment of the final 10% on final completion of erection, testing and acceptance of all the equipment to be furnished; but not later than 180 days after the date of delivery of all of the equipment to be furnished, unless testing has been completed and shows the equipment to be unacceptable.

With each invoice for periodic payment, the Contractor shall enclose a Contractor's Declaration - Section 43, and an updated project schedule per Order of Completion - Section 2.

### **Section 17 - Deductions for Uncorrected Work**

If the Supervising Professional decides it is inexpedient to correct work that has been damaged or that was not done in accordance with the Contract, an equitable deduction from the Contract price shall be made.

### **Section 18 - Correction of Work Before Final Payment**

The Contractor shall promptly remove from the premises all materials condemned by the Supervising Professional as failing to meet Contract requirements, whether incorporated in the work or not, and the Contractor shall promptly replace and re-execute the work in accordance with the Contract and without expense to the City and shall bear the expense of making good all work of other contractors destroyed or damaged by the removal or replacement.

If the Contractor does not remove the condemned work and materials within 10 days after written notice, the City may remove them and, if the removed material has value, may store the material at the expense of the Contractor. If the Contractor does not pay the expense of the removal within 10 days thereafter, the City may, upon 10 days written notice, sell the removed materials at auction or private sale and shall pay to the Contractor the net proceeds, after deducting all costs and expenses that should have been borne by the Contractor. If the removed material has no value, the Contractor must pay the City the expenses for disposal within 10 days of invoice for the disposal costs.

The inspection or lack of inspection of any material or work pertaining to this Contract shall not relieve the Contractor of its obligation to fulfill this Contract and defective work shall be made good. Unsuitable materials may be rejected by the Supervising Professional notwithstanding that the work and materials have been previously overlooked by the Supervising Professional and accepted or estimated for payment or paid for. If the work or any part shall be found defective at any time before the final acceptance of the whole work, the Contractor shall forthwith make good the defect in a manner satisfactory to the Supervising Professional. The judgment and the decision of the Supervising Professional as to whether the materials supplied and the work done under this Contract comply with the requirements of the Contract shall be conclusive and final.

### **Section 19 - Acceptance and Final Payment**

Upon receipt of written notice that the work is ready for final inspection and acceptance, the Supervising Professional will promptly make the inspection. When the Supervising Professional finds the work acceptable under the Contract and the Contract fully performed, the Supervising Professional will promptly sign and issue a final certificate stating that the work required by this Contract has been completed and is accepted by the City under the terms and conditions of the Contract. The entire balance found to be due the Contractor, including the retained percentage, shall be paid to the Contractor by the City within 30 days after the date of the final certificate.

Before issuance of final certificates, the Contractor shall file with the City:

- (1) The consent of the surety to payment of the final estimate;
- (2) The Contractor's Affidavit in the form required by Section 44.

In case the Affidavit or consent is not furnished, the City may retain out of any amount due the Contractor, sums sufficient to cover all lienable claims.

The making and acceptance of the final payment shall constitute a waiver of all claims by the City except those arising from:

- (1) unsettled liens;
- (2) faulty work appearing within 12 months after final payment;
- (3) hidden defects in meeting the requirements of the plans and specifications;
- (4) manufacturer's guarantees.

It shall also constitute a waiver of all claims by the Contractor, except those previously made and still unsettled.

## **Section 20 - Suspension of Work**

The City may at any time suspend the work, or any part by giving 5 days notice to the Contractor in writing. The work shall be resumed by the Contractor within 10 days after the date fixed in the written notice from the City to the Contractor to do so. The City shall reimburse the Contractor for expense incurred by the Contractor in connection with the work under this Contract as a result of the suspension.

If the work, or any part, shall be stopped by the notice in writing, and if the City does not give notice in writing to the Contractor to resume work at a date within 90 days of the date fixed in the written notice to suspend, then the Contractor may abandon that portion of the work suspended and will be entitled to the estimates and payments for all work done on the portions abandoned, if any, plus 10% of the value of the work abandoned, to compensate for loss of overhead, plant expense, and anticipated profit.

## **Section 21 - Delays and the City's Right to Terminate Contract**

If the Contractor refuses or fails to prosecute the work, or any separate part of it, with the diligence required to insure completion, ready for operation, within the allowable number of consecutive calendar days specified plus extensions, or fails to complete the work within the required time, the City may, by written notice to the Contractor, terminate its right to proceed with the work or any part of the work as to which there has been delay. After providing the notice the City may take over the work and prosecute it to completion, by contract or otherwise, and the Contractor and its sureties shall be liable to the City for any excess cost to the City. If the Contractor's right to proceed is terminated, the City may take possession of and utilize in completing the work, any materials, appliances and plant as may be on the site of the work and useful for completing the work. The right of the Contractor to proceed shall not be terminated or the Contractor charged with liquidated damages where an extension of time is granted under Extension of Time - Section 14.

If the Contractor is adjudged a bankrupt, or if it makes a general assignment for the benefit of creditors, or if a receiver is appointed on account of its insolvency, or if it persistently or repeatedly refuses or fails except in cases for which extension of time is provided, to supply enough properly skilled workers or proper materials, or if it fails to make prompt payments to subcontractors or for material or labor, or persistently disregards laws, ordinances or the instructions of the Supervising Professional, or otherwise is guilty of a substantial violation of any provision of the Contract, then the City, upon the certificate of the Supervising Professional that sufficient cause exists to justify

such action, may, without prejudice to any other right or remedy and after giving the Contractor 3 days written notice, terminate this Contract. The City may then take possession of the premises and of all materials, tools and appliances thereon and without prejudice to any other remedy it may have, make good the deficiencies or finish the work by whatever method it may deem expedient, and deduct the cost from the payment due the Contractor. The Contractor shall not be entitled to receive any further payment until the work is finished. If the expense of finishing the work, including compensation for additional managerial and administrative services exceeds the unpaid balance of the Contract Sum, the Contractor and its surety are liable to the City for any excess cost incurred. The expense incurred by the City, and the damage incurred through the Contractor's default, shall be certified by the Supervising Professional.

## **Section 22 - Contractor's Right to Terminate Contract**

If the work should be stopped under an order of any court, or other public authority, for a period of 3 months, through no act or fault of the Contractor or of anyone employed by it, then the Contractor may, upon 7 days written notice to the City, terminate this Contract and recover from the City payment for all acceptable work executed plus reasonable profit.

## **Section 23 - City's Right To Do Work**

If the Contractor should neglect to prosecute the work properly or fail to perform any provision of this Contract, the City, 3 days after giving written notice to the Contractor and its surety may, without prejudice to any other remedy the City may have, make good the deficiencies and may deduct the cost from the payment due to the Contractor.

## **Section 24 - Removal of Equipment and Supplies**

In case of termination of this Contract before completion, from any or no cause, the Contractor, if notified to do so by the City, shall promptly remove any part or all of its equipment and supplies from the property of the City, failing which the City shall have the right to remove the equipment and supplies at the expense of the Contractor.

The removed equipment and supplies may be stored by the City and, if all costs of removal and storage are not paid by the Contractor within 10 days of invoicing, the City upon 10 days written notice may sell the equipment and supplies at auction or private sale, and shall pay the Contractor the net proceeds after deducting all costs and expenses that should have been borne by the Contractor and after deducting all amounts claimed due by any lien holder of the equipment or supplies.

## **Section 25 - Responsibility for Work and Warranties**

The Contractor assumes full responsibility for any and all materials and equipment used in the construction of the work and may not make claims against the City for damages to materials and equipment from any cause except negligence or willful act of the City. Until its final acceptance, the Contractor shall be responsible for damage to or destruction of the project (except for any part covered by Partial Completion and Acceptance - Section 26). The Contractor shall make good all work damaged or destroyed before acceptance. All risk of loss remains with the Contractor until final acceptance of the work (Section 19) or partial acceptance (Section 26). The Contractor is advised to investigate obtaining its own builders risk insurance.

The Contractor shall guarantee the quality of the work for a period of one year. The Contractor shall also unconditionally guarantee the quality of all equipment and materials that are furnished and installed under the contract for a period of one year. At the end of one year after the Contractor's receipt of final payment, the complete work, including equipment and materials

furnished and installed under the contract, shall be inspected by the Contractor and the Supervising Professional. Any defects shall be corrected by the Contractor at its expense as soon as practicable but in all cases within 60 days. Any defects that are identified prior to the end of one year shall also be inspected by the Contractor and the Supervising Professional and shall be corrected by the Contractor at its expense as soon as practicable but in all cases within 60 days. The Contractor shall assign all manufacturer or material supplier warranties to the City prior to final payment. The assignment shall not relieve the Contractor of its obligations under this paragraph to correct defects.

## **Section 26 - Partial Completion and Acceptance**

If at any time prior to the issuance of the final certificate referred to in Acceptance and Final Payment - Section 19, any portion of the permanent construction has been satisfactorily completed, and if the Supervising Professional determines that portion of the permanent construction is not required for the operations of the Contractor but is needed by the City, the Supervising Professional shall issue to the Contractor a certificate of partial completion, and immediately the City may take over and use the portion of the permanent construction described in the certificate, and exclude the Contractor from that portion.

The issuance of a certificate of partial completion shall not constitute an extension of the Contractor's time to complete the portion of the permanent construction to which it relates if the Contractor has failed to complete it in accordance with the terms of this Contract. The issuance of the certificate shall not release the Contractor or its sureties from any obligations under this Contract including bonds.

If prior use increases the cost of, or delays the work, the Contractor shall be entitled to extra compensation, or extension of time, or both, as the Supervising Professional may determine.

## **Section 27 - Payments Withheld Prior to Final Acceptance of Work**

The City may withhold or, on account of subsequently discovered evidence, nullify the whole or part of any certificate to the extent reasonably appropriate to protect the City from loss on account of:

- (1) Defective work not remedied;
- (2) Claims filed or reasonable evidence indicating probable filing of claims by other parties against the Contractor;
- (3) Failure of the Contractor to make payments properly to subcontractors or for material or labor;
- (4) Damage to another Contractor.

When the above grounds are removed or the Contractor provides a Surety Bond satisfactory to the City which will protect the City in the amount withheld, payment shall be made for amounts withheld under this section.

## **Section 28 - Contractor's Insurance**

- (1) The Contractor shall procure and maintain during the life of this Contract, including the guarantee period and during any warranty work, such insurance policies, including those set forth below, as will protect itself and the City from all claims for bodily injuries, death or



property damage that may arise under this Contract; whether the act(s) or omission(s) giving rise to the claim were made by the Contractor, any subcontractor, or anyone employed by them directly or indirectly. Prior to commencement of any work under this contract, Contractor shall provide to the City documentation satisfactory to the City, through City-approved means (currently myCOI), demonstrating it has obtained the required policies and endorsements. The certificates of insurance endorsements and/or copies of policy language shall document that the Contractor satisfies the following minimum requirements. Contractor shall add registration@mycoitracking.com to its safe sender's list so that it will receive necessary communication from myCOI. When requested, Contractor shall provide the same documentation for its subcontractor(s) (if any).

Required insurance policies include:

- (a) Worker's Compensation Insurance in accordance with all applicable state and federal statutes. Further, Employers Liability Coverage shall be obtained in the following minimum amounts:

Bodily Injury by Accident - \$500,000 each accident  
Bodily Injury by Disease - \$500,000 each employee  
Bodily Injury by Disease - \$500,000 each policy limit

- (b) Commercial General Liability Insurance equivalent to, as a minimum, Insurance Services Office form CG 00 01 04 13 or current equivalent. The City of Ann Arbor shall be named as an additional insured. There shall be no added exclusions or limiting endorsements specifically for the following coverages: Products and Completed Operations, Explosion, Collapse and Underground coverage or Pollution. Further there shall be no added exclusions or limiting endorsements that diminish the City's protections as an additional insured under the policy. The following minimum limits of liability are required:

\$1,000,000	Each occurrence as respect Bodily Injury Liability or Property Damage Liability, or both combined.
\$2,000,000	Per Project General Aggregate
\$1,000,000	Personal and Advertising Injury
\$2,000,000	Products and Completed Operations Aggregate

- (c) Motor Vehicle Liability Insurance, including Michigan No-Fault Coverages, equivalent to, as a minimum, Insurance Services Office form CA 00 01 10 13 or current equivalent. Coverage shall include all owned vehicles, all non-owned vehicles and all hired vehicles. The City of Ann Arbor shall be named as an additional insured. There shall be no added exclusions or limiting endorsements that diminish the City's protections as an additional insured under the policy. Further, the limits of liability shall be \$1,000,000 for each occurrence as respects Bodily Injury Liability or Property Damage Liability, or both combined.

- (d) Umbrella/Excess Liability Insurance shall be provided to apply excess of the Commercial General Liability, Employers Liability and the Motor Vehicle coverage enumerated above, for each occurrence and for aggregate in the amount of \$1,000,000.

- (2) Insurance required under subsection (1)(b) and (1)(c) above shall be considered primary as respects any other valid or collectible insurance that the City may possess, including any self-insured retentions the City may have; and any other insurance the City does possess shall be considered excess insurance only and shall not be required to contribute with this insurance. Further, the Contractor agrees to waive any right of recovery by its

insurer against the City for any insurance listed herein.

- (3) Insurance companies and policy forms are subject to approval of the City Attorney, which approval shall not be unreasonably withheld. Documentation must provide and demonstrate an unconditional and un-qualified 30-day written notice of cancellation in favor of the City of Ann Arbor. Further, the documentation must explicitly state the following: (a) the policy number(s); name of insurance company(s); name and address of the agent(s) or authorized representative(s); name(s), email address(es), and address of insured; project name; policy expiration date; and specific coverage amounts; (b) any deductibles or self-insured retentions which may be approved by the City, in its sole discretion; (c) that the policy conforms to the requirements specified Contractor shall furnish the City with satisfactory certificates of insurance and endorsements prior to commencement of any work. Upon request, the Contractor shall provide within 30 days a copy of the policy(ies) and all required endorsements to the City. If any of the above coverages expire by their terms during the term of this Contract, the Contractor shall deliver proof of renewal and/or new policies and endorsements to the Administering Service Area/Unit at least ten days prior to the expiration date.
- (4) Any Insurance provider of Contractor shall be authorized to do business in the State of Michigan and shall carry and maintain a minimum rating assigned by A.M. Best & Company's Key Rating Guide of "A-" Overall and a minimum Financial Size Category of "V". Insurance policies and certificates issued by non-authorized insurance companies are not acceptable unless approved in writing by the City.
- (5) City reserves the right to require additional coverage and/or coverage amounts as may be included from time to time in the Detailed Specifications for the Project.
- (6) The provisions of General Condition 28 shall survive the expiration or earlier termination of this contract for any reason.

## **Section 29 - Surety Bonds**

Bonds will be required from the successful bidder as follows:

- (1) A Performance Bond to the City of Ann Arbor for the amount of the bid(s) accepted;
- (2) A Labor and Material Bond to the City of Ann Arbor for the amount of the bid(s) accepted.

Bonds shall be executed on forms supplied by the City in a manner and by a Surety Company authorized to transact business in Michigan and satisfactory to the City Attorney.

## **Section 30 - Damage Claims**

The Contractor shall be held responsible for all damages to property of the City or others, caused by or resulting from the negligence of the Contractor, its employees, or agents during the progress of or connected with the prosecution of the work, whether within the limits of the work or elsewhere. The Contractor must restore all property injured including sidewalks, curbing, sodding, pipes, conduit, sewers or other public or private property to not less than its original condition with new work.

## **Section 31 - Refusal to Obey Instructions**

If the Contractor refuses to obey the instructions of the Supervising Professional, the Supervising Professional shall withdraw inspection from the work, and no payments will be made for work performed thereafter nor may work be performed thereafter until the Supervising Professional shall have again authorized the work to proceed.

## **Section 32 - Assignment**

Neither party to the Contract shall assign the Contract without the written consent of the other. The Contractor may assign any monies due to it to a third party acceptable to the City.

## **Section 33 - Rights of Various Interests**

Whenever work being done by the City's forces or by other contractors is contiguous to work covered by this Contract, the respective rights of the various interests involved shall be established by the Supervising Professional, to secure the completion of the various portions of the work in general harmony.

The Contractor is responsible to coordinate all aspects of the work, including coordination of, and with, utility companies and other contractors whose work impacts this project.

## **Section 34 - Subcontracts**

The Contractor shall not award any work to any subcontractor without prior written approval of the City. The approval will not be given until the Contractor submits to the City a written statement concerning the proposed award to the subcontractor. The statement shall contain all information the City may require.

The Contractor shall be as fully responsible to the City for the acts and omissions of its subcontractors, and of persons either directly or indirectly employed by them, as it is for the acts and omissions of persons directly employed by it.

The Contractor shall cause appropriate provisions to be inserted in all subcontracts relative to the work to bind subcontractors to the Contractor by the terms of the General Conditions and all other contract documents applicable to the work of the subcontractors and to give the Contractor the same power to terminate any subcontract that the City may exercise over the Contractor under any provision of the contract documents.

Nothing contained in the contract documents shall create any contractual relation between any subcontractor and the City.

## **Section 35 - Supervising Professional's Status**

The Supervising Professional has the right to inspect any or all work. The Supervising Professional has authority to stop the work whenever stoppage may be appropriate to insure the proper execution of the Contract. The Supervising Professional has the authority to reject all work and materials which do not conform to the Contract and to decide questions which arise in the execution of the work.

The Supervising Professional shall make all measurements and determinations of quantities. Those measurements and determinations are final and conclusive between the parties.

## **Section 36 - Supervising Professional's Decisions**

The Supervising Professional shall, within a reasonable time after their presentation to the Supervising Professional, make decisions in writing on all claims of the City or the Contractor and on all other matters relating to the execution and progress of the work or the interpretation of the contract documents.

## **Section 37 - Storing Materials and Supplies**

Materials and supplies may be stored at the site of the work at locations agreeable to the City unless specific exception is listed elsewhere in these documents. Ample way for foot traffic and drainage must be provided, and gutters must, at all times, be kept free from obstruction. Traffic on streets shall be interfered with as little as possible. The Contractor may not enter or occupy with agents, employees, tools, or material any private property without first obtaining written permission from its owner. A copy of the permission shall be furnished to the Supervising Professional.

## **Section 38 - Lands for Work**

The Contractor shall provide, at its own expense and without liability to the City, any additional land and access that may be required for temporary construction facilities or for storage of materials.

## **Section 39 - Cleaning Up**

The Contractor shall, as directed by the Supervising Professional, remove at its own expense from the City's property and from all public and private property all temporary structures, rubbish and waste materials resulting from its operations unless otherwise specifically approved, in writing, by the Supervising Professional.

## **Section 40 - Salvage**

The Supervising Professional may designate for salvage any materials from existing structures or underground services. Materials so designated remain City property and shall be transported or stored at a location as the Supervising Professional may direct.

## **Section 41 - Night, Saturday or Sunday Work**

No night or Sunday work (without prior written City approval) will be permitted except in the case of an emergency and then only to the extent absolutely necessary. The City may allow night work which, in the opinion of the Supervising Professional, can be satisfactorily performed at night. Night work is any work between 8:00 p.m. and 7:00 a.m. No Saturday work will be permitted unless the Contractor gives the Supervising Professional at least 48 hours but not more than 5 days notice of the Contractor's intention to work the upcoming Saturday.

## **Section 42 - Sales Taxes**

Under State law the City is exempt from the assessment of State Sales Tax on its direct purchases. Contractors who acquire materials, equipment, supplies, etc. for incorporation in City projects are not likewise exempt. State Law shall prevail. The Bidder shall familiarize itself with the State Law and prepare its Bid accordingly. No extra payment will be allowed under this Contract for failure of the Contractor to make proper allowance in this bid for taxes it must pay.

## Section 43

### CONTRACTOR'S DECLARATION

I hereby declare that I have not, during the period \_\_\_\_\_, 202\_\_, to \_\_\_\_\_, 202\_\_, performed any work, furnished any materials, sustained any loss, damage or delay, or otherwise done anything in addition to the regular items (or executed change orders) set forth in the Contract titled \_\_\_\_\_, for which I shall ask, demand, sue for, or claim compensation or extension of time from the City, except as I hereby make claim for additional compensation or extension of time as set forth on the attached itemized statement. I further declare that I have paid all payroll obligations related to this Contract that have become due during the above period and that all invoices related to this Contract received more than 30 days prior to this declaration have been paid in full except as listed below.

There is/is not (Contractor please circle one and strike one as appropriate) an itemized statement attached regarding a request for additional compensation or extension of time.

\_\_\_\_\_  
Contractor

\_\_\_\_\_  
Date

By \_\_\_\_\_  
(Signature)

Its \_\_\_\_\_  
(Title of Office)

Past due invoices, if any, are listed below.

Section 44

**CONTRACTOR'S AFFIDAVIT**

The undersigned Contractor, \_\_\_\_\_, represents that on \_\_\_\_\_, 202\_\_\_\_, it was awarded a contract by the City of Ann Arbor, Michigan to \_\_\_\_\_ under the terms and conditions of a Contract titled \_\_\_\_\_. The Contractor represents that all work has now been accomplished and the Contract is complete.

The Contractor warrants and certifies that all of its indebtedness arising by reason of the Contract has been fully paid or satisfactorily secured; and that all claims from subcontractors and others for labor and material used in accomplishing the project, as well as all other claims arising from the performance of the Contract, have been fully paid or satisfactorily settled. The Contractor agrees that, if any claim should hereafter arise, it shall assume responsibility for it immediately upon request to do so by the City of Ann Arbor.

The Contractor, for valuable consideration received, does further waive, release and relinquish any and all claims or right of lien which the Contractor now has or may acquire upon the subject premises for labor and material used in the project owned by the City of Ann Arbor.

This affidavit is freely and voluntarily given with full knowledge of the facts.

\_\_\_\_\_ Date

By \_\_\_\_\_  
(Signature)

Its \_\_\_\_\_  
(Title of Office)

Subscribed and sworn to before me, on this \_\_\_\_\_ day of \_\_\_\_\_, 202\_\_\_\_  
\_\_\_\_\_, \_\_\_\_\_ County, Michigan

Notary Public  
\_\_\_\_\_ County, MI

My commission expires on:

## **STANDARD SPECIFICATIONS**

All work under this contract shall be performed in accordance with the Public Services Department Standard Specifications in effect at the date of availability of the contract documents stipulated in the Bid. All work under this Contract which is not included in these Standard Specifications, or which is performed using modifications to these Standard Specifications, shall be performed in accordance with the Detailed Specifications included in these contract documents.

Standard Specifications are available online:

<http://www.a2gov.org/departments/engineering/Pages/Engineering-and-Contractor-Resources.aspx>

## DETAILED SPECIFICATION FOR PROJECT SCHEDULE

Examination of Plans, Specifications, and Work Site: Bidders shall carefully examine the Bid Form, plans, specifications and the work site until the Bidder is satisfied as to all local conditions affecting the contract and the detailed requirements of construction. The submission of the bid shall be considered prima facie evidence that the Bidder has made such examination and is satisfied as to the conditions to be encountered in performing the work and all requirements of the contract.

The entire work under this Contract shall be completed in accordance with, and subject to, the scheduling requirements as outlined below, and all other requirements of the Contract Documents.

1. By no later than **May 8, 2020** the Contractor shall submit a detailed schedule of work for the Engineer's review and approval. The proposed schedule must fully comply with the scheduling requirements contained in this Detailed Specification. The Contractor shall update the approved work schedule each week and present it to the Engineer at the weekly progress meeting.
2. The Contractor will receive two (2) copies of the Contract, for his/her execution, on or before **March 25, 2020**. The Contractor shall properly execute both copies of the Contract and return them, with the required Bonds and Insurance Certificate, to the City by **April 15, 2020**.
3. Contractor may begin construction on or before **June 12, 2020**, and only after receiving the copy of executed contract documents and the Notice to Proceed from the City. Appropriate time extensions shall be granted if the Notice to Proceed is delayed due to the circumstances controlled by the City.
4. By **October 31, 2020**, or within **one-hundred forty-two (142)** calendar days from the date of Notice to Proceed, the Contractor must install the new water main; all of the required service leads to the water main and complete all the remaining work under this Contract for **Barton Drive Water Main Replacement and Resurfacing Project** including, but not limited to installation of the storm water structures, the installation of new sidewalk and sidewalk ramps, the restoration of all disturbed areas, permanent placement of hot mix asphalt and/or concrete, and the removal of any and all traffic control devices. Failure to complete all work as specified herein within the times specified herein, including time extensions granted thereto as determined by the Engineer, shall entitle the City to deduct from the payments due the Contractor, **\$400.00** in "Liquidated Damages", and not as a penalty, for each and every calendar day beyond the allowed number of calendar days to complete the above specified work. In addition, failure to complete all work described in any Milestone or Phase of construction will also entitle the City to deduct from the payments due the Contractor, **\$400.00** in "Liquidated Damages", and not as a penalty, for each and every calendar day beyond the specified date for the specified work.
5. **Work day, hour, and other work restrictions imposed by the City of Ann Arbor.**  
The work hours described may be modified or changed by the Engineer due to Holidays, Special Events, or Traffic Volumes.

Contractors operations shall be limited by local municipality work time, noise, and dust ordinance unless approved by the local municipality and the Engineer in writing, as shown below:

- Monday – Friday: 7am-8pm
- Saturday: 7am-8pm; Notice given to City of Ann Arbor no less than 48 hours



and no more than 5 days.

- Sunday: only with approval from the City of Ann Arbor
- No work may be done on Holidays

No work, unless approved by the Engineer, shall be performed during:

- Fourth of July
  - 3: 00 pm Wednesday July 3, 2020 - 7:00 am Monday July 6, 2020
- Labor Day
  - 7:00 am Saturday September 5, 2020 – 7:00 am Tuesday, September 8, 2020

## **MILESTONES**

### **1. MILESTONE 1: CONSTRUCTION PART ONE**

The work of this Milestone is separated into four phases. The construction sequence for this project shall be as follows:

**Phase I** shall consist of the installation of the Detour and Local Traffic Control outlined for Phase I, water main installation in the south side of Barton Drive from Longshore Drive to Pontiac Trail, water service leads transferred (road plates and traffic regulators will be necessary for water service leads to north side properties), storm structures and sewer installed, and any necessary grading and concrete work for new sidewalks, sidewalk ramps, and existing driveways on the south side of Barton Drive between Longshore Drive and Pontiac Trail.

By **July 25, 2020** the Contractor must complete all work on Phase I of Barton Drive Water Main Replacement and Resurfacing Project including, but not limited to: install, swab, chlorinate, pressure test, and flush the new water main pipe on Barton Drive. Successfully complete of all required bacteriological testing and place the new water main into service.

**Phase IA** shall consist of the installation of the Local Traffic Control outlined for Phase IA, water main installation and tie-in to Pontiac Trail water main in Pontiac Trail, storm structures and sewer installed, and any necessary grading and concrete work for new sidewalks and sidewalk ramps on the south side of Barton Drive at Pontiac Trail.

By **August 5, 2020** the Contractor must complete all work on Phase IA of Barton Drive Water Main Replacement and Resurfacing Project including, but not limited to: install, swab, chlorinate, pressure test, and flush the new water main pipe on Pontiac Trail. Successfully complete of all required bacteriological testing and place the new water main into service and abandon the existing water main.

**Phase II** shall consist of the installation of the Local Traffic Control outlined for Phase II, installation of storm structures and sewer, any necessary grading and concrete work for new sidewalks and sidewalk ramps on the south side of Barton Drive between eastbound M14 on ramp and Longshore Drive, and cold milling HMA surface and paving Barton Drive between eastbound M14 on ramp and Pontiac Trail.

By **August 15, 2020** the Contractor must complete all work on Phase II of Barton Drive Water Main Replacement and Resurfacing Project.

**Phase III** shall consist of the installation of the Local Traffic Control outlined for Phase

III, installation of storm structures and sewer, and any necessary grading and concrete work for replacement driveways, new curbs, sidewalks and sidewalk ramps at the intersection of Barton Drive and Starwick Drive. This work will be done under flag control during working hours and open to two way – two lane traffic outside of working hours.

By **September 5, 2020** the Contractor must complete all work on Phase III of Barton Drive Water Main Replacement and Resurfacing Project, including but not limited to, restoring all pavement, striping all necessary pavement markings, the removal of all temporary traffic control specific to Phase III, and open to traffic.

**Phase IV** shall consist of the installation of the Local Traffic Control outlined for Phase IV, installation of storm structures and sewer, and any necessary grading for new shoulders and concrete work for replacement driveways, new curbs, sidewalks and sidewalk ramps, cold milling HMA surface, paving the roadway and asphalt driveways on the north side of Barton Drive between M14 overpass and Pontiac Trail. All pavement markings between eastbound M14 on ramp and Pontiac Trail need to be installed, the detour and local traffic control removed, and the road **open to traffic** within Phase IV.

By **September 26, 2020** the Contractor must complete all work on Phase IV of Barton Drive Water Main Replacement and Resurfacing Project.

## **2. MILESTONE 2: CONSTRUCTION PART TWO AND OPEN TO TRAFFIC**

The work of this Milestone has one phase. The construction sequence for this Phase V shall be as follows:

**Phase V** shall consist of the installation of the Local Traffic Control outlined for Phase V, cold milling HMA surface, paving the roadway, and installing pavement markings on Barton Drive between the City Limits (westbound M14 on ramp) and the eastbound M14 on ramp. This work will be done under flag control during working hours and open to two way – two lane traffic outside of working hours.

By **October 10, 2020** the Contractor must complete all work on Phase V of Barton Drive Water Main Replacement and Resurfacing Project, including but not limited to, removal of Phase V traffic control devices and **open to traffic**.

## **3. MILESTONE 3: FINAL ACCEPTANCE AND PROJECT COMPLETION**

Final Acceptance and restoration shall be completed on or before **October 31, 2020**.

The Contractor may propose to adjust the limits or sequencing of construction in order to complete the work more efficiently. Changes to the recommended construction sequence must be approved in writing by the Engineer prior to construction and must assure all required coordination with other projects and time lines.

The City will not allow any shut down of existing water mains without prior written approval of construction methods and timing of shut down, by the City of Ann Arbor and the Engineer. All water main valves are to be operated by City of Ann Arbor personnel.

Time is of the essence in the performance of the work of this contract. The Contractor is expected to mobilize sufficient personnel and equipment, and work throughout all authorized hours in order to complete the project by the final completion date. Costs for the Contractor to organize, coordinate, and schedule all of the work

of the project, will not be paid for separately, but shall be included in the bid price of the Contract Item "General Conditions, Max \$30,000."

Failure to complete all work as specified herein within the times specified herein, including time extensions granted thereto as determined by the Engineer, shall entitle the City to deduct from the payments due the Contractor, **\$400.00** in Liquidated Damages, and not as a penalty, for delays in the completion of the work for each and every calendar day beyond the completion date for each sub-phase, as detailed in the phasing above.

Liquidated Damages will be assessed until the required work is completed in the current construction season. If, with the Engineer's approval, work is extended beyond seasonal limitations, the assessment of Liquidated Damages will be discontinued until the work is resumed in the following construction season.

# **DETAILED SPECIFICATION FOR MAINTENANCE OF TRAFFIC**

## **DESCRIPTION**

Traffic shall be maintained in accordance with the City of Ann Arbor Public Services Department Standard Specifications except as specified in Sections 104.11, 812, and 922 of the Michigan Department of Transportation (MDOT) 2012 Standard Specifications for Construction, the Michigan Manual of Uniform Traffic Control Devices, Latest Revised Edition (MMUTCD) and as amended herein.

The Contractor shall furnish, erect, maintain and, upon completion of the work, remove all traffic control devices within the project and around the perimeter of the project for the safety and protection of local traffic. This includes, but is not limited to, advance, regulatory, and warning signs; barricades and channeling devices at intersecting streets or detour streets on which traffic is to be maintained; barricades at the ends of the project and at right-of-way lines of intersecting streets; portable changeable message signs; lighted arrow boards, temporary signs, ramps and mat for pedestrian detours, and moving traffic control devices for construction operations. Payment shall be paid for as "Minor Traffic Devices, Max \$20,000".

## **MATERIALS**

The materials and equipment shall meet the requirements specified in the corresponding sections of the MDOT 2012 Standard Specifications for Construction and MMUTCD. The approximate quantities of materials are as follows: 4 Portable Changeable Message Signs, 1700 ft Black Pavement Marking Tape, Type R, 800 sft Temporary Signs, Type B, 30 Type III Barricades, 30 Type II Barricades, 50 Channelizing Devices, 180 Type II Lighted Plastic Drums, 1100 ft Temporary 4 inch white tape, 500 ft Temporary 4 inch Yellow Tape, 50 ft Temporary 6 inch White Tape, 20 ft Temporary 24 inch White Tape, 4 Temporary Pedestrian Ramps, 20 Temporary Pedestrian Mats, 4 Audible Message Devices, 40 ft Temporary Curb, and various Sign Covers.

## **Maintenance of Local Traffic**

Unless otherwise indicated on the plans, all side roads east of Pontiac Trail, near the intersection of Barton Drive and Starwick Drive intersection shall not be closed to through traffic except during construction operations of short duration and only upon written approval of the Engineer.

Local access shall be maintained at all times for emergency vehicles, refuse pick-up, mail delivery and ingress/egress to private properties.

Contractor must accommodate the safe access to the residential buildings, businesses, and parks located within construction area.

A lane-closure permit shall be obtained by the Contractor from the Engineering Division, at least 48 hours in advance of any proposed lane or street closing. The Contractor shall acquire a PIN (password) from Customer Service, login to eTRAKIT and apply for the permit. The issued permit shall be printed and displayed on site at all times.

The hours of work on all Local streets are 7:00 a.m. to 8:00 p.m., Monday through Saturday, or as specified on the lane-closure permit. No equipment will be allowed in the street before or after these hours. Local streets may only be closed to through traffic (local access only) with written authorization of the Engineer. Aside from the detour, work must be completed each day such that all streets are re-opened to through traffic by 8:00 p.m. unless otherwise specified, directed, or authorized in writing by the Engineer. All major changes in traffic control shall be made either between 9:30 a.m. and 3:30 p.m., or between 7:00

p.m. and 8:00 p.m. in order to minimize interference with rush-hour traffic. All traffic controls must be in-place and ready for traffic each day by 7:00 a.m.

Driveways shall not be blocked for extended periods of time unless arrangements can be made with the affected property owner(s) or resident(s). When it becomes necessary to temporarily block driveways, the Contractor shall notify the affected property owners in advance to coordinate the work and allow sufficient time for vehicles to vacate from properties. It may be necessary to allow for vehicles to temporarily park in the roadway at locations that do not interfere with the Contractor's work. During these periods the owners of the respective vehicles must be available to, with proper notice, move their vehicles if it becomes necessary to accommodate the work.

The Contractor shall maintain pedestrian traffic at all times covered under the pay item "Minor Traffic Devices, Max \$20,000". For maintaining normal pedestrian traffic while performing sidewalk and driveway repair, Type I barricades shall be placed by the Contractor, as directed by the Engineer. "Sidewalk Closed" and/or "Cross Here" signs shall be placed, by the Contractor, when directed by the Engineer.

During the construction of the water main, storm sewer, and road rehabilitation, parking of residences in the construction area will not be allowed. Temporary "No Parking" signs will be supplied by the City. "No Parking" signs shall be erected after MISS DIG clearance (at least 48 hours prior to enforcement), maintained throughout the project duration, and salvaged and returned to the City of Ann Arbor at the W. R. Wheeler Service Center at the completion of the project, as described in the Detailed Specification for "No Parking" Signs. They will be paid for at the Contract Unit Price for ""No Parking" Signs". The Contractor shall fill out the "Temporary Permission to Reserve Parking Lane for Work-Related Purposes" form for each street and submit to the City of Ann Arbor Engineering Unit at least five (5) business days in advance of sign installation. Any vehicle parked in the construction zone shall be ticketed and towed at the owner's expense.

At times when it becomes necessary to temporarily obstruct local traffic during the performance of the work, the Contractor shall provide traffic regulation in conformance with Chapter 6E of the MMUTCD. A minimum of two traffic regulators are required. The cost of traffic regulation shall be included in the contract pay item "Minor Traffic Devices, Max \$20,000"

The Contractor shall use quantities of dust palliative, maintenance aggregate, and hot patching mixture for use as temporary base, surfacing, and dust control at utility crossings, side roads and driveways (wherever required to maintain traffic), and where directed by the Engineer to maintain local access. The cost for the use of dust palliative, maintenance aggregate and HMA wedging mixture, as required and directed by the Engineer for maintenance of traffic and local access, shall be included in contract pay item "General Conditions, Max. \$30,000" and it will not be paid for separately.

The Contractor shall perform the work of this Contract while maintaining traffic in accordance with the Contract Documents as specified herein. No traffic shall be allowed on newly placed asphalt surfaces until rolling has been satisfactorily completed and the surface has cooled sufficiently to prevent damage from traffic (170 degrees Fahrenheit). This is to be accomplished by traffic regulators and by relocating traffic control devices to prevent traffic from entering the work area until such time that it can be safely maintained without damaging the new construction. The Contractor shall provide traffic regulators in sufficient number to maintain traffic as described herein, and to keep traffic off sections being surfaced, and provide for safe travel at all times as directed by the Engineer. "No Parking" signs shall stay in effect on all newly placed asphalt surfaces for at least three days.

Each pressure distributor, paver and roller shall be equipped with at least one approved flasher light which shall be mounted on the equipment so as to give a warning signal ahead and behind.

There may be areas where the Engineer directs the paving of less than the full width of a phase to

stagger the paving joints and to accommodate changes in crown and/or cross-sectional dimensions/locations. In these locations the gravel base courses shall be constructed to the full area of the phase, and the Contractor shall place traffic control devices on the base course grade as necessary, and shall place, maintain, and remove maintenance aggregate (MDOT 21AA) all as necessary, and as directed by the Engineer, to maintain local traffic to side streets and drives.

The City will not allow any shut down of existing water mains without prior written approval of construction methods and timing of shut down, by the City of Ann Arbor and the Engineer. Two (2) business days notice shall be given to the Engineer. All water main valves are to be operated by City of Ann Arbor personnel.

The Contractor shall place portable, changeable message signs (PCMs) a minimum of one week prior to the start of construction in locations indicated by the Engineer. PCMs shall be the smaller of the two MDOT and MMUTCD approved message signs so they can fit on Pontiac Trail in the lawn extension or the limited right-of-way beyond the sidewalk.

Before the detour of Barton Drive, the Contractor shall coordinate their activities with the City Public Works and the Signal Unit prior to setting up signs and rerouting traffic. Coordination with the Signal Unit shall be maintained throughout the following activities:

1. Barton will be closed to Thru Traffic from M14 to Pontiac
2. There will be a Road Closed Ahead sign at M14, two-way/two lane local traffic in front of the fronting Barton houses, Hard Road Closure just east of last fronting driveway
3. East of the hard closure, we will close Barton west of Brede and allow EB traffic for local traffic only. Residents will have to cut thru the neighborhood to get to their houses and only travel eastbound to get out.
4. At Barton/Pontiac intersection during duration of project:
  - a. Change WB Barton lane usage signs
  - b. Place "Do Not Enter signs on the west side of intersection, north and south sides of road
  - c. Cover NB Barton Left turn panel near signal
  - d. Close left turn lane for NB Pontiac
  - e. Run 2-phase color signal
5. During Water Main Tie-in and paving Pontiac:
  - a. Signal will be a 4 phase flashing red
  - b. Cover SB Pontiac left turn panel near signal
  - c. Close SB left turn lane for two-way/two-lane traffic shifted to the east through the intersection
  - d. More NB Pontiac left turn lane closure to the south for 5.c. above
6. Detour pedestrians at side streets Longshore, Chandler, Northside behind the work zone, in front of the barricades with temp ramps and mats where necessary
7. Temporary bump-out Barton Drive at Pontiac on the south side to ensure EB traffic is only using one lane

## **DETAILED SPECIFICATION FOR COORDINATION AND COOPERATION WITH OTHERS AND WORK BY OTHERS**

The Contractor is reminded as to the requirements of article 104.07 of the 2012 edition of the MDOT Standard Specifications, "Cooperation by the Contractor."

The Contractor shall directly coordinate his/her work with individual City Departments/Divisions/Units.

The Contractor is hereby notified that the City of Ann Arbor Public Works Unit may be installing traffic control conduits, traffic signal sensors, and the like, at various locations.

No additional compensation will be paid to the Contractor, and no adjustments to contract unit prices will be made, due to delays and/or the failure of others in the performance of their work, nor for delays due to the encountering of existing utilities that are, or are not, shown on the Plans.

The following Utility Owners may have overhead and/or underground facilities located within the Right-of-Way:

- The City of Ann Arbor
- DTE - MichCon (Michigan Consolidated Gas Company)
- DTE - Edison (Detroit Edison Company)
- AT&T
- Comcast
- MCI Communications
- Windstream Fiber Optics

### **On all projects:**

**"3 Working Days before you Dig - Call MISS DIG - Toll Free" Phone No. 1-800-482-7171.**

The Owners of public or private utilities which will not interfere with the completed project and which do not present a hazard to the public or an extraordinary hazard to the Contractor's operations will not be required to move their facilities on or from the street right-of-way.

Stoppages created solely by the operations of the utility companies which delay utility revisions on any portion of this project may be considered as a basis of claim for an extension of time for project completion.

Costs for this work will not be paid for separately, but shall be included in the bid price of the Contract Item "General Conditions, Max \$30,000."

The Contractor is hereby notified that there may be other construction projects, not associated with this project, scheduled for construction during the same timeframe as this project within the local vicinity.

The following is a listing of known road construction projects within the local vicinity that may have an impact on this project. Please note that this listing may not be complete and the Contractor shall verify any other projects within the local vicinity that may impact this project.

- Northside STEAM SRTS Sidewalk Gaps will be under construction.
- Ann Arbor Annual Street Resurfacing project will be ongoing.
- Dhu Varren Sidewalk Gap will be under construction.

- Riverview Sanitary and Water Extension will be under construction.
- Hoover / Hill /Green Improvement Project will be under construction
- Glen / Fuller Sanitary Diversion will be under construction.
- Wheeler Service Center PUD Non-motorized Improvements will be under construction.
- Miscellaneous private utility relocations with intermittent closures are anticipated.

The Contractor shall coordinate its work on this project with that by the Contractor on other projects, as directed by the Engineer. No additional compensation will be allowed for costs incurred by the Contractor due to coordinating with or delays caused by other projects.



## **DETAILED SPECIFICATION FOR SOIL EROSION CONTROL**

The Contractor shall furnish, place, maintain and remove soil erosion and sedimentation control measures, including but not limited to, silt fence and fabric filters at all drainage structures, all in accordance with all applicable City (and other governmental agencies) codes and standards, as directed by the Engineer, as detailed in the Standard Specifications, and as shown on the Plans.

### **DESCRIPTION**

This work consists of installing and maintaining inlet filters in accordance with Section 208 of the 2012 Michigan Department of Transportation Standard Specifications for Construction and as shown on the plans. Filters shall be installed in existing and proposed inlets in order to minimize the erosion of soil and the sedimentation of water courses. The related work includes the installation, maintenance and removal of the filter cloth, cleaning as required during the performance of the project work, removing and disposing of accumulated sediment, and replacement of filters if required by the Engineer so as to provide a properly working inlet filter and a well-drained site.

### **MATERIALS**

The inlet filters shall be in accordance with the REGULAR FLOW SILTSACK® manufactured by ACF Environmental (800) 448-3636; FLEXSTORM® Style FX manufactured by Advanced Drainage Systems, Inc. (800) 821-6710; CATCH-ALL® manufactured by Price & Company (866) 960-4300, or Engineer approved equal.

The Contractor shall submit product data sheets and a sample of the filter material for inlet filters for Engineer approval prior to ordering materials.

### **METHODS OF CONSTRUCTION**

The Contractor shall install, maintain, clean, and re-install and/or replace inlet filters in accordance with the manufacturer's specifications and as directed by the Engineer. The Contractor shall dispose of debris off-site.

Costs for this work will not be paid for separately, but shall be included in the bid price of the Contract Item "General Conditions, Max \$30,000."

**DETAILED SPECIFICATION  
FOR  
VACUUM TYPE STREET AND  
UTILITY STRUCTURE CLEANING EQUIPMENT**

The Contractor shall furnish and operate throughout the construction period, vacuum type street cleaning and utility structure cleaning equipment (Vac-All, Vactor, etc.) approved by the Engineer, as and when directed by the Engineer for dust control, for dirt/debris control, and for street cleaning immediately prior to, and for street and utility structure cleaning after any and all paving. The cleaning equipment shall be of sufficient power to remove dust, dirt, and debris from the pavement and from utility structures in and adjacent to the construction area.

Costs for this work will not be paid for separately, but shall be included in the bid price of the Contract Item "General Conditions, Max \$30,000."

**DETAILED SPECIFICATION  
FOR  
MATERIALS AND SUPPLIES CERTIFICATIONS**

The following materials and supplies shall be certified by the manufacturer or supplier as having been tested for compliance with the Specifications:

- HMA materials
- Hot-poured Joint Sealants
- Cements, coatings, admixtures and curing materials
- Sands and Aggregates
- Steel and Fabricated metal
- Portland Cement Concrete Mixtures
- Reinforcing Steel for Concrete
- Reinforcing Fibers for Concrete
- Pre-cast Concrete products
- Sanitary Sewer Pipe
- Storm Sewer Pipe
- Water Main Pipe
- High Density Polyethylene Pipe
- Edge Drain and Underdrain Pipe
- Geotextile Filter Fabric and Stabilization Fabric/Grids

The Contractor shall submit all certifications to the Engineer for review and approval a minimum of three business days prior to any scheduled delivery, installation, and/or construction of same.

Costs for this work will not be paid for separately, but shall be included in the bid price of the Contract Item "General Conditions, Max \$30,000."

**DETAILED SPECIFICATION  
FOR  
CONTRACT DRAWINGS/PLANS**

Bidders shall carefully check and review all Drawings, plans, and specifications, and advise the Engineer of any errors or omissions discovered. The Drawings/Plans may be supplemented by such additional Drawings/Plans and sketches as may be necessary or desirable as the work progresses. The Contractor shall perform all work shown on any additional or supplemental Drawings/Plans issued by the Engineer.

Bidders shall carefully examine the Bid Form, preliminary layouts, specifications, and the work sites until the Bidder is satisfied as to all local conditions affecting the contract and the detailed requirements of construction. The submission of the bid shall be considered prima facie evidence that the Bidder has made such examination and is satisfied as to the conditions to be encountered in performing the work and all requirements of the contract.

**DETAILED SPECIFICATION  
FOR EXISTING  
SOIL BORING AND PAVEMENT SECTION DATA**

Data pertaining to existing soil borings and pavement sections which may be included in these Contract Documents are provided to help the Engineer and Contractor determine the soil conditions existing within the construction area. The City in no way guarantees existing conditions to be the same as shown in the data. The Contractor is solely responsible for any and all conclusions he/she may draw from the data.

**DETAILED SPECIFICATION  
FOR  
WORKING IN THE RAIN OR IN THE DARK**

***Working in the Rain***

The Contractor shall not work in the rain unless authorized in writing by the Engineer.

The Engineer may delay or stop the work due to threatening weather conditions.

The Contractor shall not be compensated for unused materials or downtime due to rain, or the threat of rain.

The Contractor is solely responsible for repairing all damages to the work and to the site, including road infrastructures, road subgrades, and any adjacent properties, which are caused as a result of working in the rain.

***Working in the Dark***

The Contractor shall not work in the dark except as approved by the Engineer.

The Engineer may stop the work, or may require the Contractor to defer certain work to another day, if, in the Engineer's opinion, the work cannot be completed within the remaining daylight hours, or if inadequate daylight is present to either properly perform or inspect the work.

The Contractor will not be compensated for unused materials or downtime, when delays or work stoppages are directed by the Engineer for darkness and/or inadequate remaining daylight reasons.

The Contractor is solely responsible for repairing all damages to the work and to the site, including road infrastructures, road subgrades, and any adjacent properties, which are caused as a result of working in the dark.

**DETAILED SPECIFICATION  
FOR  
QUANTITIES AND UNIT PRICES**

Quantities as given are approximate and are estimated for bidding purposes. Quantities are not guaranteed and may vary by any amount. While it is the City's intent to complete the project substantially as drawn and specified herein, quantities may be changed or reduced to zero for cost savings or other reasons. **The City reserves the right to change the quantities, delete streets, or add streets, and no adjustment in unit price will be made for any change in any quantity.**

# **DETAILED SPECIFICATION FOR WATER MAIN INSTALLATION AND TESTING**

## **DESCRIPTION**

This Detailed Specification is intended to supplement the current City of Ann Arbor Standard Specifications for Construction with regard to water main installation and hydrologic and bacteriologic testing. It is also intended to establish minimum requirements for the work that the Contractor is responsible to follow.

## **CONSTRUCTION METHODS**

During the delivery, handling, installation, and testing of the water main, the Contractor shall comply with the following requirements:

1. Keep all pipe clean and neatly stacked a minimum of six-inches off of the ground at all times. Ends of pipe shall be covered to prevent entry of dust, dirt, small animals, and any other objectionable matter at all times. During installation of the water main and all appurtenances no dirt, soil, or non-potable water shall be allowed to enter the pipe. If dirt, soil, or non-potable water does enter the pipe, the Contractor shall completely remove it prior to installing the next segment of pipe. Segments of pipe that have visible signs of contamination including, but not limited to; soil, dirt, mud, oil, grease, solvents, animal droppings, etc. shall have all visible traces of the offending substance completely removed by the Contractor in a manner acceptable to the Engineer. Sections of pipe or fittings that have been marked by the Engineer for cleaning shall not be approved for installation until such time as the Engineer has again approved them for use on the project. Acceptable methods of cleaning include flushing and/or power washing, compressed air, or other methods that the Engineer may approve. Approval by the Engineer of a cleaning method shall not be construed by the Contractor to include acceptance of the water main for the purposes of placing it into service. Water main pipe and fittings that have been placed shall remain covered on the advancing end until the next segment of pipe is connected. The Contractor may uncover no more than three segments of pipe in advance of placement. Water main pipe and fittings that have been laid out further in advance of the installation operation must remain covered.
2. Gasket lubricant shall only be applied immediately before connection to the next segment of pipe. Pipe with lubricant applied shall not come in contact with the ground. If the lubricated portion of the pipe end contacts the ground, it shall be thoroughly cleaned to the satisfaction of the Engineer, prior to its installation.
3. All water main shall be swabbed in accordance with the requirements of Section 3H, Flushing and Swabbing, of the current edition of the City of Ann Arbor Public Services Department Standards. During swabbing of the water main, the swab shall be flushed through the pipe in accordance with the manufacturer's recommendations and in a manner that is acceptable to the Engineer. The Contractor shall submit the product data of the swab from the manufacturer, for review and approval by the Engineer, at or before the pre-construction meeting.
4. Swabbing of the water main shall be followed immediately by flushing of the pipe so that any disturbed particles are washed out before they can resettle. The pipe shall be flushed in accordance with Section 3H, Flushing and Swabbing, of the current edition of the City of Ann Arbor Public Services Department Standard Specifications. The pipe shall be flushed until the water runs clear for a minimum of fifteen minutes or until two full pipe volumes have been flushed (whichever is longer.) Flushing from the existing water main that is to be replaced shall not be allowed.
5. During the chlorination process, the proper level of chlorination must be achieved throughout the entire length pipe. Chlorine levels shall be checked at intermediate locations as directed by the Engineer and the Contractor shall add chlorine until such time as the required levels are achieved



at all points. The “plug method” of chlorinating the pipe shall not be allowed. The Contractor shall chlorinate the proposed water main to a minimum residual concentration of 100 parts per million with commercial liquid chlorine solution. The chlorine concentrate shall be a minimum of 10% chlorine (sodium hypochlorite) by volume. Solid chlorine “pellets” or powder shall not be allowed. Any chlorine containing compound used on the project shall be approved by the Engineer. The minimum recommended dosage of chlorine (sodium hypochlorite) is as follows (based on 10% available chlorine):

**Recommended Minimum Chlorine Dosage to Disinfect 100 L.F. of Pipe**

<u>Pipe Diameter</u>	<u>10% Chlorine Solution (gallons)</u>
6	0.306
8	0.544
10	0.852
12	1.226
16	2.180
20	3.406
24	4.904

6. Bacteriological testing shall be performed by the City with the Contractor present. The Engineer shall determine the number, location, and type of testing points for each section of water main being tested. Bacteriological samples shall only be drawn from copper or brass sampling points. The use of galvanized steel blow-offs or sampling points are strictly prohibited. Obtaining bacteriological samples from fire hydrants will not be allowed.
7. If a new water main fails two consecutive sets of bacteriological tests, the Engineer may require the Contractor to re-swab the water main in accordance with Section 3H, Flushing and Swabbing, as described above. Additional flushing, prior to subsequent bacteriological sampling will also be required. The required additional swabbing and flushing of the water main by the Contractor shall be performed at no additional cost to the City of Ann Arbor.

**MEASUREMENT AND PAYMENT**

Payment for all labor, materials, and equipment that is required to comply with this Detailed Specification shall be considered as part of the unit price as bid for each respective water main pipe and fitting and will not be paid for separately.

Payment for all water main pipe shall be as follows:

The Contractor shall be paid for 50% of the water main pipe installed upon satisfactory completion of the installation and backfilling of the water main pipe. The remaining 50% shall be paid upon successful completion of all required bacteriological testing, the water main has been placed into service, and all water service leads have been connected and are in service.

**DETAILED SPECIFICATION  
FOR  
ASPHALTIC SEAL COATINGS  
DUCTILE IRON PIPE FITTINGS**

**DESCRIPTION**

The Contractor may not operate City water main valves. For valve operation, contact the City of Ann Arbor Public Services Area. It is recommended that the Contractor request that the existing valves, which will need to be operated in order to perform the water main work, are checked in advance of the work to ensure that they operate properly.

Several items of work on this project require coordination with the City of Ann Arbor Public Services Area (The City). The Contractor shall notify the City three (3) full working days in advance of any items requiring coordination with the City.

The Contractor shall complete the water main work in a manner which minimizes the disruption of water service. No shut downs shall occur on Saturdays or Sundays. Shut downs shall not be for longer than 8.0 hours for any given shutdown event. Liquidated damages as detailed and described on pages C-1 and C-2 of these documents shall apply to any shut downs that occur on Saturday or Sunday or for a period of time longer than 8.0 hours in any given 24 hour period.

The Contractor shall be responsible for coordination with the City of Ann Arbor Public Services Area for the installation of 1-inch corporations in the gate wells to be used for testing and filling of new main. The Contractor shall pay the City of Ann Arbor's Public Works Unit all costs associated with installing the corporations.

The Contractor must have all materials, fittings, pumps and other miscellaneous equipment, and personnel on site before the City of Ann Arbor Public Services Area personnel will prepare and shutdown an existing main.

The Contractor shall dig-up and expose utility crossings 60-feet in advance of laying any water main pipe in their vicinity. This will allow the Engineer to adjust the grade of the water main, if possible, to avoid the existing utilities. The costs of the advance excavations, and related costs, shall be included in the respective items of work listed in the Bid Form. Some dig-ups may need to occur out of line.

All ductile iron pipe and fittings shall have an asphaltic seal coat on their cement-mortar linings. The coatings shall meet the requirements of ANSI/NSF Standard 61, Drinking Water System Components - Health Effects, and be approved for contact with drinking water.

**MEASUREMENT AND PAYMENT**

Asphaltic seal coat for ductile iron pipe and fittings shall not be measured or paid for separately. This work shall include all labor, materials and equipment costs necessary to provide asphaltic seal coat of ductile iron pipe and fittings. Payment for this work shall be considered as part of the unit price for each respective ductile iron pipe and fitting unit price.

# DETAILED SPECIFICATION FOR CONCRETE DURABILITY

## DESCRIPTION

The Contractor shall furnish a Portland cement concrete mixture for this project that has been tested under this specification and shown to be resistant to excessive expansion caused by alkali-silica reactivity (ASR) and provides adequate air entrainment for freeze thaw durability. The Contractor shall construct the project with practices outlined in this specification.

## MATERIALS

The materials provided for use on this project shall conform to the following requirements:

Portland cement	ASTM C 150
Fine Aggregate	ASTM C 33*
Coarse Aggregate	ASTM C 33*
Fly Ash, Class F	ASTM C 618
Slag Cement, Grade 100, 120	ASTM C 989
Silica Fume	ASTM C 1240
Blended Cements	ASTM C-595
Air Entraining Admixtures	ASTM C-260
Chemical Admixtures	ASTM C-494
White Membrane Cure	ASTM C-309 Type 2

\* Fine and coarse aggregates shall consist of natural aggregates as defined in the 2012 MDOT Standard Specifications Section 902.

The Contractor shall provide documentation that all materials to be incorporated into proposed mixed designs meet the requirements of this section.

## Alkali-Silica Reactivity

The Contractor shall supply to the Engineer preliminary concrete mix designs including a list and location of all suppliers of concrete materials. The Contractor shall evaluate the mixtures for the potential for excessive expansion caused by ASR and provide documentation to the Engineer. The Contractor's evaluation shall include a review of any previous testing of the material sources intended to be used for both the fine and coarse aggregates for the concrete mixtures. The previous testing may be from other projects or records provided by the material suppliers.

Aggregates shall be tested under ASTM C-1260. If the expansion of the mortar bars is less than 0.10%, at 14 days, the aggregates shall be considered innocuous and there are no restrictions for ASR mitigation required with this material.

Previous aggregate test data may be used. If no previous test data is available, for the concrete mix, that shows that it is resistant to ASR, a concrete mixture that will mitigate the potential for ASR must be designed using either method 1 or 2 as described below.

**Method 1.** Substitution of a portion of the cement with Class F Fly Ash, Slag Cement Grade 100 or 120 or a ternary mix (blended cement) containing a blend of Portland cement and slag cement, or Class F fly ash, or silica fume.

The maximum substitution of cement with the fly ash permitted shall be 25% by weight of total cementitious material (cement plus fly ash). Additional requirements for the Fly Ash, Class F are that the Calcium Oxide (CaO) percent shall be less than 10 % and the available alkalis shall not exceed a maximum of 1.5%. A copy of the most recent mill test report shall be submitted to verify. Note: a Class C fly ash with a minimum total oxides ( $\text{SiO}_2 + \text{Al}_2\text{O}_3 + \text{Fe}_2\text{O}_3$ ) of 66% and a minimum  $\text{SiO}_2$  of 38% may be used in lieu of Type F fly ash.

The maximum substitution of cement with the Slag Cement permitted shall be 40% by weight of total cementitious material (cement plus Slag Cement). The minimum replacement rate with Slag Cement shall be 25%.

For a ternary blend the total replacement of supplementary cementitious materials is 40% with a blend consisting of a maximum of 15% type F fly ash, and/or 8% silica fume and/or slag cement.

For method 1, the effectiveness of the proposed mix combination to resist the potential for excessive expansion caused by ASR shall be demonstrated using current or historic data. To demonstrate the effectiveness of the proposed mix the Contractor shall construct and test mortar bars per ASTM C1567 (14 day test) using both the fine and coarse aggregate along with the proposed cementitious material for the concrete mixture. If a mortar bar constructed of these materials produces an expansion of less than 0.10%, concrete mixture will be considered to be resistant to excessive expansion due to ASR.

If a mortar bar constructed produces an expansion of 0.10% or greater, concrete mixtures containing these materials shall not be considered resistant to the potential for excessive expansion due to ASR and shall be rejected. Additional testing, including alternate proportions or different materials will be required.

**Method 2.** Use low alkali cement and maintain the total alkali content from the cementitious at no more than 3.0 lbs/cyd ( $\text{Na}_2\text{O}_{\text{eq}}$ ). The total alkali contribution is calculated by the quantity contained in the Portland cement only.

Requirements for Low Alkali Cement are that the alkali content does not exceed 0.60% expressed as  $\text{Na}_2\text{O}$  equivalent. Equivalent sodium oxide is calculated as: (percent  $\text{Na}_2\text{O} + 0.658 \times$  percent  $\text{K}_2\text{O}$ ).

For either method 1 or 2, if the Contractor intends to change any component material supplied after the mix design has been approved all concrete work will be suspended with no cost to the project or extensions of time, unless approved, until evaluation of the new mixtures and testing of the new materials demonstrates that it is resistant to excessive expansion due to ASR.

The Engineer and Contractor shall monitor the concrete that is delivered to the project site so as to insure that the approved mix design is being followed. The supplier shall include on the delivery ticket for each batch of concrete delivered to the job, the identification and proportions of each material batched.

When concrete is placed during cold weather, defined for the purposes of this Detailed Specification to be, air temperatures below 40° F, the use of accelerators, heated aggregates, silica fume and/or additional forms of cold weather protection will be required. Cold weather will not eliminate the requirement for furnishing and placing a concrete mix that is considered resistant to ASR attack.

Prior to cool weather placement, defined for the purposes of this detailed specification to be, air temperatures between 40° and 60° F, the set time of the proposed mix shall be verified under anticipated field conditions. This information shall be used when scheduling pours and saw crews.

### **Air Entrainment**

Air entrainment shall be accomplished by addition of an approved air entraining agent. Air content as determined by ASTM C 231 or ASTM C 173, shall be determined on each day of production as early and as frequently as necessary until the air content is consistently acceptable. If during the period of time while adjustments are being made to the concrete to create a mixture that is consistently acceptable, concrete is produced that does not meet the requirements of this Detailed Specification, the Engineer may reject the material and direct it to be removed from the jobsite. Any rejected material shall be removed from the

jobsite at the Contractor's sole expense. Quality Control testing performed by the Contractor to ensure compliance with the project specifications shall be performed on the grade ahead of the placement operation.

**Paver placement:** During production, the plastic concrete material shall be tested for acceptance at a point ahead of the paver. The air content of the concrete mixture that the Contractor shall provide shall be known as the Acceptance Air Content (AAC). The Contractor shall also provide additional entrained air in the concrete mixture to account for the air loss which occurs in the concrete mixture experienced during transportation, consolidation and placement of the concrete. The "air loss" shall be added to the air content of the concrete mixture as established on the approved concrete mix design. The AAC for the project will be 6.0% plus an amount equal to the air loss.

For up to the first four loads, the air content measured on-site prior to placement shall be at least 8.0% and no more than 12.0%. To establish the initial AAC on the first day of paving, the air content of the first load shall be tested at the plant. After initial testing at the plant the Contractor shall provide at least two sample sets to determine the actual air loss during placement. A sample set shall consist of two samples of concrete from the same batch, one taken at the point of discharge and the other from the in-place concrete behind the paver. The air loss from the two sample sets shall be averaged and added to 6.0% to establish the AAC (rounded to the next higher 0.5%). After the testing and adjustment procedure(s) have been completed, the project acceptance air tests shall be taken prior to placement. The Contractor shall provide concrete to the jobsite that has an air content of plus 2.0%, or minus 1.0%, of the AAC.

After the AAC has been established, it shall be verified and/or adjusted through daily checks of the air loss through the paver. The Contractor shall check the air loss through the paver a minimum of two times a day. A Revised AAC shall be required to be established by the Contractor if the average air loss from two consecutive tests deviates by more than 0.5% from the current accepted air loss. The testing operations performed by the Contractor to establish a revised AAC shall be performed to the satisfaction of the Engineer. The Contractor shall be solely responsible for any delays and/or costs that occur to the project while establishing revised AACs.

**Hand placed concrete:** The air content for non-slip-form paving shall be 7.0% plus 1.5%, or minus 1.0%, at the point of placement.

## **CONSTRUCTION METHODS**

### **Aggregate Control**

**Gradation control** – The supplier shall provide a detailed stockpile management plan, describing their process control procedure for shipping, handling, and stockpiling of each aggregate including workforce training.

**Moisture control** – All aggregate materials must be conditioned to a moisture content of not less than saturated surface dry (SSD) prior to batching. A watering process using an effective sprinkler system designed and operated by the Contractor shall be required on all coarse aggregate material stockpiles.

The Contractor shall provide verification that these processes have been performed by the supplier. The Engineer reserves the right to independently verify that the supplier has complied with these standards.

### **Mixing**

**Central mix plants** - The total volume of the batch shall not exceed the designated size of the mixer or the rated capacity as shown on the manufacturer's rating plate.

**Drum Mix Plants:** After all solid materials are assembled in the mixer drum; the mixing time shall be a minimum of 60 seconds and a maximum of 5 minutes. The mixing time may be decreased if the ASTM

C-94 11.3.3 mixer efficiency tests show that the concrete mixing is satisfactory. The Engineer may require an increase in the minimum mix time if the mixer efficiency test determines that the concrete is not being mixed satisfactorily. The minimum mixing time shall start after the mixer is fully charged. Mixers shall be operated at the speed recommended by the manufacturer as mixing speed. The mixer shall be charged so that a uniform blend of materials reached the mixer throughout the charging cycle. Any additional slump water required shall be added to the mixing chamber by the end of the first 25% of the specified mixing time. Mixers shall not be used if the drum is not clean or if the mixing blades are damaged or badly worn

Ribbon mixers: After all solid materials are assembled in the mixer; the mixing time shall be a minimum of 30 seconds and a maximum of 2.5 minutes. The mixing time may be decreased if the ASTM C-94 11.3.3 mixer efficiency tests show that the concrete mixing is satisfactory. The Engineer may require an increase in the minimum mix time if the mixer efficiency test determines that the concrete is not being mixed satisfactorily. The minimum mixing time shall be indicated by an accurate timing device which is automatically started when the mixer is fully charged. Mixers shall be operated at the speed recommended by the manufacturer as mixing speed. The mixer shall be charged so that a uniform blend of materials reached the mixer throughout the charging cycle. After any additional slump water is added to the mixing chamber the mixing shall continue for a minimum of 10 seconds. Mixers shall not be used if the mixer is not clean or if the mixing blades are damaged or badly worn.

**Truck Mixers** -The capacities and mixing capabilities shall be as defined in ASTM C 94, and each unit shall have an attached plate containing the information described therein. The plate may be issued by the Truck Mixer Manufacturer. The mixer capacity shall not be exceeded, and the mixing speeds shall be within the designated limits. Truck mixers shall be equipped with a reliable reset revolution counter. If truck mixers are used for mixing while in transit, the revolution counter shall register the number of revolutions at mixing speed.

An authorized representative of the concrete producer shall certify that the interior of the mixer drum is clean and reasonably free of hardened concrete, that the fins or paddles are not broken or worn excessively, that the other parts are in proper working order, and that the unit has been checked by the representative within the previous 30 calendar day period to substantiate this certification. The current, signed certification shall be with the unit at all times.

The required mixing shall be between 70 and 90 revolutions. The mixing shall be at the rate designated by the manufacturer and shall produce uniform, thoroughly mixed concrete.

The Engineer may inspect mixer units at any time to assure compliance with certification requirements, and removal of inspection ports may be required. Should the Engineer question the quality of mixing, the Engineer may check the slump variation within the batch. Should the slump variation between two samples taken, one after approximately 20% discharge and one after approximately 90% discharge of the batch, show a variation greater than 3/4 inch (20 mm) or 25% of the average of the two, whichever is greater, the Engineer may require the mixing to be increased, the batch size reduced, the charging procedure be modified or the unit removed from the work.

The practice of adding water on the site shall be discouraged. After the slump of the concrete in the first round of trucks has been adjusted on-site, the amount of water added at the plant shall be adjusted accordingly for that day's work. All additions of water on site shall be approved by the Engineer.

### **Curing**

Apply liquid curing compound in a fine atomized spray to form a continuous, uniform film on the horizontal surface, vertical edges, curbs and back of curbs immediately after the surface moisture has disappeared, but no later than 30 minutes after concrete placement. With approval of the Engineer, the timing of cure application may be adjusted due to varying weather conditions and concrete mix properties.

The cure system shall be on site and tested prior to concrete placement.

Apply a curing compound at a rate of application not less than 2 gallons per 25 square yards. The Contractor shall keep the material thoroughly mixed per the Manufacturer's recommendations. The curing compound shall not be diluted.

The finished product shall appear as a uniformly painted solid white surface. Areas exhibiting a blotchy or spotty appearance shall be recoated immediately.

### **COMPLIANCE WITH STANDARDS**

The Engineer will review and approve all material test reports and mix designs supplied by the Contractor before any placement of concrete. The Engineer will visually inspect the placed concrete and review the concrete test reports prior to final acceptance.

Acceptance sampling and testing will be performed using the sampling method and testing option selected by the Engineer. Acceptance testing will be performed at the frequency specified by the Engineer. Quality control measures to insure job control are the responsibility of the Contractor. The Engineer's testing and/or test results will not relieve the Contractor from his/her responsibilities to produce, deliver, and place concrete that meets all project requirements. The Engineer's test results are for acceptance purposes only.

If the results of the testing are not in compliance with the project specifications, the Engineer shall determine appropriate corrective action(s). Time extensions will not be granted to the Contractor during the time that the Engineer is determining the necessary corrective actions.

If, in the Engineer's judgment, the rejected material must be replaced, the material in question will be removed and replaced at the Contractor's sole expense. The removal costs will be deemed to include all relevant and associated costs including, but not limited to; re-mobilization, traffic control, re-grading the aggregate base course, if required, placement of material meeting the project specifications, and all other expenses. Time extensions will not be granted to the Contractor for any required repair work to meet the requirements of this specification.

If the Engineer decides that the material in question can remain in place, an adjustment to the contract unit price(s) may be made of up to 100% of the bid price(s) for the affected items of work.

### **MEASUREMENT AND PAYMENT**

The cost associated with complying with the requirements as described herein, including any required remedial action(s), shall be included in the cost of other items of work and shall not be paid for separately.

# **DETAILED SPECIFICATION FOR HMA PAVING**

## **DESCRIPTION**

Hot Mix Asphalt (HMA) pavement base, leveling, and top courses shall be constructed in accordance with Section 501 of the 2012 MDOT Standard Specifications for Construction, except as modified herein, and as directed by the Engineer.

## **CONSTRUCTION METHODS**

**Equipment-** All equipment shall conform to Section 501.03.A of the 2012 MDOT Standard Specifications, except as modified herein.

The Contractor shall have a 10 foot long straight edge, rubber-tired backhoe (Case 580 type, or equivalent), air-compressor with the ability to develop a minimum pressure of 100 pounds per square inch and continuous rated capacity of 150 cubic feet per minute of air flow, and jackhammer available during all paving operations. The Contractor shall be required to perform any miscellaneous cleaning, trimming, material removal, and other tasks as required by the Engineer in order to ensure the proper and orderly placement of all HMA materials on this project.

The Contractor shall provide sufficient rollers to achieve the specified asphalt densities.

At various times throughout the work, the Engineer may direct the Contractor to use smaller and/or lighter equipment, and to defer certain work tasks, in order to protect the grade and/or adjacent areas; including hauling units. The Contractor shall not be entitled to any additional compensation for the use of smaller equipment, lighter equipment, or work task deferral.

**Cleaning and Bond Coat application-** Cleaning and bond coat application shall be performed in accordance with Sections 501.03.C and 501.03.D of the 2012 MDOT Standard Specifications, except as modified herein, and as directed by the Engineer.

The Contractor shall furnish and operate throughout the construction period, vacuum-type street cleaning and utility structure cleaning equipment (Vac-All, Vactor, etc.) approved by the Engineer, and when directed by the Engineer, for street cleaning immediately prior to, and for street and utility structure cleaning after any and all paving. The cleaning equipment shall be of sufficient power to remove dust, dirt, and debris from the pavement and from utility structures in and adjacent to the construction area. The vac-all or similar equipment and shall be approved by the Engineer prior to beginning the work. The equipment used shall have an effective means for preventing any dust resulting from the operation from escaping into the air.

The bond coat shall be applied at a minimum rate of 0.10 gallons/yd<sup>2</sup>. Before placing the bond coat, the existing pavement surface shall be thoroughly cleaned. The Contractor shall also thoroughly clean all joints, cracks, and edges to a minimum depth of one inch with compressed air, vac-all type equipment, or other approved mechanical or hand methods, to remove all dirt, debris, and all foreign material.



**HMA Placement-** Placement shall conform to Section 501.03.F of the 2012 MDOT Standard Specifications, except as modified herein, and as directed by the Engineer.

HMA placement shall not commence until a “Permit to Place” (no additional costs are required to obtain this permit) has been issued in writing by the Engineer. The Permit to Place shall be issued after the aggregate base course or the adjacent, underlying layer of pavement section has been approved by the Engineer.

The final structure adjustments must be approved by the Engineer prior to the issuance of the “Permit to Place” for the wearing course.

The top course shall be placed with a ¼” lip at the gutter edge of metal.

All HMA thickness dimensions are compacted-in-place.

**Paving Operation Scheduling** – The Contractor shall schedule the paving operation to avoid longitudinal cold joints that would be required to be left “open” overnight.

In all cases, the Contractor shall pave the primary road’s through-traffic lanes (“main line”) first, from point-of-beginning to the point-of-ending. All other paving including, but not limited to; acceleration and deceleration lanes, intersection approaches, and center left-turn lanes shall be paved following completion of main line paving, unless authorized by the Engineer prior to the placement of any pavement.

**Rate of Paver operation** - The rate of the paver’s travel shall be maintained such that the paving operation will be continuous, resulting in no transverse cold joints, but shall never exceed the rate of 50 feet per minute.

The Contractor shall furnish and operate enough material, equipment, and hauling units so as to keep the paving machine(s) moving continuously at all times. Failure to do so shall be cause for the suspension of the paving operation until the Contractor can demonstrate to the satisfaction of the Engineer, that sufficient resources have been dedicated to perform the work in accordance with the project specifications.

**Longitudinal and Transverse Joints-** shall conform to Section 502.03.F of the 2012 MDOT Standard Specifications and as specified herein.

For mainline HMA paving, the width of the mat for each pass of the paver shall be not less than 10.5’, nor greater than 15’, except as noted in the plans and as directed by the Engineer. The Engineer will direct the layout of all HMA longitudinal joints during construction.

Prior to placing the adjacent paving pass on the leveling and wearing courses of HMA, the Contractor shall cut and remove 6” to 8” of the previously placed pavement at the free edge of the pavement by means of a coultter wheel. The Engineer reserves the right to reject any method(s) for cutting the pavement that does not provide a vertical and satisfactory edge, free of tearing, bending, or other deformations, as determined by the Engineer. Any method(s) employed by the Contractor shall be completely effective. The cut edge shall have a uniform bead of pavement joint adhesive applied to the full-height of the joint. The removal of this HMA material and resulting edge must be approved by the Engineer prior to proceeding with the placement of the succeeding pass of HMA. The base course of HMA and its vertical edge will have bond coat applied in accordance with Section 501.03.D. All costs associated with complying with these requirements will not be paid for separately, but shall be considered to be included in the items of work “HMA Pavement Leveling/Top – LVSP”.

Pavement joint adhesive shall be hot-applied, meet, or exceed, the following properties, and be approved by the Engineer prior to performing HMA placement:

Brookfield Viscosity, 400°F, ASTM D2669 – 4,000 to 10,000 cp  
Cone Penetration, 77°F, ASTM D5329 – 60 to 100  
Flow, 140°F, ASTM D5329 – 5mm maximum  
Resilience, 77°F, ASTM D5329 – 30% minimum  
Ductility, 77°F, ASTM D113 – 30 cm minimum  
Ductility, 39.2°F, ASTM D113 – 30 cm minimum  
Tensile Adhesion, 77°F, ASTM D5329 – 500% minimum  
Softening Point, ASTM D36 - 170°F minimum  
Asphalt Compatability, ASTM D5329 – pass

**Feather Joints** – shall be constructed so as to vary the thickness of the HMA from zero inches to the required paving thickness at the rate of approximately 1.5” over a distance of 10 feet, or as directed by the Engineer. The Contractor shall rake the larger pieces of aggregate out of feather joints prior to compaction.

**Butt Joints** - Construction of butt joints, where directed by the Engineer, shall conform to Section 501.03.C.3 and 501.03.C.4 of the 2012 MDOT Standard Specifications, except as modified herein.

When a butt joint is specified or directed to be placed by the Engineer, remove the existing HMA surface to the thickness of the proposed overlay, or full-depth, as directed by the Engineer, for the full width or length of the joint. The HMA material shall be sawcut to the directed depth along the pavement edge or removal line to prevent tearing of the pavement surface. Cut joints that will be exposed in the completed surface must be cut with a saw or a cold-milling machine or other methods approved by the Engineer. Joints that will be covered by HMA must be cut with a saw, a cold-milling machine, or other methods approved by the Engineer.

**Rakers**- the Contractor shall provide a minimum of two rakers during the placement of all wearing and leveling courses.

**Faulty Mixtures** – The Contractor and Engineer shall carefully observe the paving operation for signs of faulty mixtures. Points of weakness in the surface shall be removed or corrected by the Contractor, at his/her sole expense, prior to paving subsequent lifts of bituminous material. Such corrective action may include the removal and replacement of thin or contaminated sections of pavement, segregated HMA, and any sections that are weak or unstable. Once the Contractor or his representative is notified by the Engineer that the material being placed is out of allowable tolerances, or that there is a problem with the paving operation, the Contractor shall stop the paving operation at once, and shall not be permitted to continue placing bituminous material until again authorized by the Engineer. Any costs associated with meeting the requirements specified herein shall not be paid for separately, but shall be included in the item(s) of work being performed at the time the faulty mixture was discovered.

#### **MEASUREMENT AND PAYMENT**

Unused HMA remaining in trucks after the work is completed shall be returned to the plant and re-weighed, and the corrected weight slip shall be provided to the Engineer. No payment will be made for the unused HMA material. All weight slips must include the type of mixture (codes are not acceptable), as well as vehicle number, gross weight, tare weight and net weight.

All costs of meeting the requirements of this special provision shall be included in the bid prices for HMA items in the proposal and will not be paid for separately.

# **DETAILED SPECIFICATION FOR ACCEPTANCE OF HMA MIXTURES**

## **A. DESCRIPTION**

This special provision establishes sampling and testing acceptance criteria for HMA Mixtures placed on City of Ann Arbor projects. The HMA mixtures shall meet all the requirements of Section 501 of the MDOT 2012 Standard Specifications for Construction, except as modified herein.

## **B. CONTRACTOR QUALITY CONTROL**

The Contractor must have a quality control plan as required by Section 501.03.M and as stipulated herein. The Quality Control (QC) Plan shall be submitted to the Engineer within 30 days of contract award or 14 days before the placement of any HMA materials, whichever date comes first. The QC Plan shall cover all aspects of HMA production, transportation, placement, and compaction. The Contractor shall have a QC representative on-site at all times during the paving operations to monitor and direct all paving-related operations. The placement of HMA shall not commence until such time as the QC Plan has been accepted by the Engineer. The Engineer's acceptance of the QC Plan shall not be construed as a basis of acceptance of any HMA materials, HMA placement results, or a waiver of any requirement(s) of the project specifications.

## **C. MATERIALS**

Aggregates, mineral filler (if required), and asphalt binder shall be combined as necessary to produce a mixture proportioned within the specification requirements including aggregate gradation; the mix design criteria including volumetric properties; the Superpave Gyrotory (SGC) compaction criteria; and the uniformity tolerances listed in Table 1. Topsoil, clay, or loam shall not be added to aggregates which are to be used in plant mixed HMA mixtures.

## **D. MIX DESIGNS**

The Contractor shall submit mix designs for evaluation in accordance with the Michigan Department of Transportation Hot Mix Asphalt Production Manual. All mix designs shall be submitted for review a minimum of 3 weeks prior to the anticipated placement of the HMA. Do not begin production and placement of the HMA until receipt of the Engineer's approval of the JMF. The Contractor's production and paving schedules shall be considered to include the mix design review and approval process. Delays associated with the submittal, or re-submittal, of the required information shall not be a basis for an extension of contract time.

## **E. CONSTRUCTION**

Target air voids shall be 3.5% in leveling courses, top courses and shoulders paved in the same operation as the leveling and top courses. Target air voids shall be 3% in base courses and shoulders not paved in the same operation as the leveling and top courses. Pedestrian paths shall have a target air void content of 3%.

After the job-mix-formula (JMF) is established, the parameters identified in Table 1 shall be maintained within the Range 1 tolerance limits of Table 1. However, if deviations are predominately either below, or above, the JMF, the Engineer may order alterations in the plant to bring the mixture into better conformance

with the JMF.

The mixture will be considered out-of-specification, as determined by the acceptance tests, if for any one mixture, two consecutive tests per parameter (for Parameter 6, two consecutive aggregate gradations on one sieve) are outside Range 1 or Range 2 tolerance limits. If a parameter is outside of Range 1 tolerance limits and the second consecutive test shows that the parameter is outside of Range 2, then it will be considered to be a Range 1 out-of-specification. Consecutive refers to the production order and not necessarily the testing order. Out-of-specification mixtures are subject to rejection per Section f. Rejected Mixtures or a price adjustment per Section g. Price Adjustments of this special provision as determined by the Engineer.

Contractor paving operations will be suspended when the mixture is determined to be out-of-specification. Contract time will continue during periods when paving operations are suspended or when dispute resolution testing and investigations are occurring. The Engineer may issue a Notice of Non-Compliance with Contract Requirements (Form 1165), if the Contractor has not suspended operations and taken corrective action. The Contractor shall submit a revised JMF or proposed alterations to the plant and/or materials to achieve the JMF to the Engineer. Effects on the Aggregate Wear Index (AWI) and mix design properties shall be taken into consideration. Production and placement of HMA material shall not resume until receipt of the Engineer's approval to proceed.

For production/mainline-type paving, obtain the minimum number of samples as shown in Table 2, each being 20,000 grams, each day of production, for each mix type. The Engineer will sample the HMA and maintain possession of each sample. Sampling from the paver hopper is prohibited. Each sample will be divided into two 10,000 gram halves with one half being used for initial testing and the other half being held for possible dispute resolution testing. Obtain a minimum of three samples for each mix type regardless of the number of days of production.

Ensure all persons performing Quality Control (QC) and Quality Assurance (QA) HMA field sampling are "Local Agency HMA Sampling Qualified" samplers. The Engineer shall obtain the QA samples from the hauling units in accordance with MTM 313 (Sampling HMA Paving Mixtures.) The samples shall be representative of the day's paving. Sample collection shall be spaced throughout the planned tonnage as directed by the Engineer. At a minimum, one sample will be obtained in the first half of the planned tonnage and, as a minimum, the second sample will be obtained in the second half of the tonnage. If planned paving is reduced or suspended, when paving resumes, the remaining sampling must be representative of the original intended sampling timing.

Samples shall be taken from separate loads as directed by the Engineer.

Ensure all persons performing testing are Bit Level One certified or Bit QA/QC Technician certified. Acceptance testing will be performed by the Engineer using the testing method selected by the Engineer. Quality control measures to ensure job control are the sole responsibility of the Contractor.

The test method for measuring asphalt content (AC) shall be MTM 325 (Quantitative Extraction of Bitumen from HMA Paving Mixtures). Back calculations to determine AC content will not be allowed.

All labs performing local agency acceptance testing shall be qualified labs as defined in the HMA Production Manual and participate in the MDOT round robin process, or they must be AASHTO Materials Reference Laboratory (AMRL) accredited for AASHTO T 30 or T 27, and AASHTO T 164 or T 308. Independent testing labs must not have conflicts of interest with the Contractor or Local Agency. On non-National Highway System (NHS) routes, Contractor labs may be used, but they must be qualified labs as previously stated. The Contractor shall provide copies of this documentation to the Engineer for review a minimum of 21 calendar days prior to the performance of any paving operations on the project.

Contractor labs may not be used for acceptance testing on NHS routes.

Material acceptance testing will be completed by the Engineer within 5 calendar days, except holidays and Sundays, after the Engineer has obtained the samples. QA test results will be provided to the Contractor after the Engineer receives the QC test results. Failure on the part of the Engineer or the laboratory to provide Quality Assurance test results within the specified time frame does not relieve the Contractor of their responsibility to provide an asphalt mix within specifications. The Contractor's schedule shall be deemed to include these material testing timeframes.

For production/mainline-type paving, the mixture may be accepted by visual inspection up to a quantity of 250 tons per mixture type, per project (not per day). For non-production-type paving defined as driveways, approaches, and patching, visual inspection may be allowed regardless of the tonnage.

The crushed particle content of the aggregate used in the HMA mixture shall not be more than 10 percentage points above or below the crushed particle content used in the JMF, nor less than the minimum specified for the aggregates in the contract documents.

Pavement density will be measured by the Engineer with a nuclear density gauge using the Gmm from the JMF for the density control target. The required in-place density of the HMA shall be between 92.0 and 96.0 percent of the density control target. The Contractor is responsible for establishing a rolling pattern that will achieve the required in-place density. Should the specified target densities not be met, the material shall be considered to have a Range 2 failure and shall be rejected. If the Engineer determines that the material is suitable to remain in place, a 50% reduction to the base price of all material affected shall be enacted by the Engineer. Should the Engineer determine that the material cannot remain in place, the affected material will be removed and replaced at the Contractor's sole expense as detailed in the Section F. "Rejected Mixtures."

After placement, roll the HMA mixture as soon after placement as the roller is able to bear without undue displacement or cracking. Start rolling longitudinally at the sides of the lanes and proceed toward the center of the pavement, overlapping on successive trips by at least half the width of the drum. Ensure each required roller is 8 tons minimum in weight unless otherwise approved by the Engineer.

Ensure the initial breakdown roller is capable of vibratory compaction and is a maximum of 500 feet behind the paving operations. The maximum allowable speed of each roller is 3 miles per hour (mph) or 4.5 feet per second. Ensure all compaction rollers complete a minimum of two complete rolling cycles prior to the mat temperature cooling to 180 degrees Fahrenheit (F). Continue finish rolling until all roller marks are eliminated and no further compaction is possible. The Engineer will verify and document that the roller pattern has been followed and density has been achieved. The Engineer can stop the placement of HMA when the roller pattern is not followed and density is not obtained. Contract time shall continue during this period and the Contractor shall be responsible for any additional costs incurred due to this work stoppage.

Pavement in-place density tests will be completed by the Engineer during paving operations and prior to traffic staging changes. Pavement in-place density acceptance testing will be completed by the Engineer prior to the Contractor being allowed to pave subsequent lifts of HMA or the newly placed HMA being opened to traffic.

**HMA Acceptance Criteria**  
**Table 1 – Uniformity Tolerance Limits for HMA Mixtures**

Parameter		Top and Leveling Courses		Base Course	
		*Range 1	Range 2	*Range 1	Range 2
Number	Description				
1	Air Voids	± 0.60	± 1.00	± 0.60	± 1.00
2	VMA	± 0.60	± 1.00	± 0.60	± 1.00
3	G <sub>mm</sub> (maximum specific gravity of mixture)	± 0.013	± 0.020	± 0.013	± 0.020
4	Fines to Effective Binder Ratio (this parameter is independent of JMF)	0.6 to 1.2	0.6 to 1.4	0.6 to 1.2	0.6 to 1.4
5	Binder Content	± 0.30	± 0.40	± 0.30	± 0.40
6	Percent Passing No. 8 and Larger Sieves	± 5.0	± 8.0	± 7.0	± 9.0
	Percent Passing No. 30 Sieve	± 4.0	± 6.0	± 6.0	± 9.0
	Percent Passing No. 200 Sieve	± 1.0	± 2.0	± 2.0	± 3.0
7	Crushed Particle Content	Below 10%	Below 15%	Below 10%	Below 15%
*This range allows for normal mixture and testing variations. The mixture shall be proportioned to test as closely as possible to the Job-Mix-Formula.					

The tolerances specified in Table 1, with the exception of the Fines to Effective Binder Ratio, reflect variations from the approved job-mix formula.

Parameter Number 6 as shown in Table 1 is aggregate gradation. Each sieve will be evaluated on one of the three gradation tolerance categories. If more than one sieve is exceeding Range 1 or Range 2 tolerances, the sieve with the largest difference from the JMF will be counted as the gradation parameter. The master gradation should be maintained throughout production; however, price adjustments will come by Table 1.

Extraction/gradation and volumetric tests will be performed by the Engineer to confirm conformance to the specifications and the tolerances identified in Table 1. The minimum number of samples to be obtained and tested shall be in accordance with Table 2.

**Table 2 – Minimum Number of Samples**

Quantity (tons) of Single Mixture Placed per Day	Minimum Number of Samples per Mixture per Day
<100	0
101 – 250	1
251 – 1,500	3
1,501 – 3,000	5
3,001 – 4,500	as directed by the Engineer

**F. REJECTED MIXTURES**

If, for any one mixture, two consecutive tests per parameter (for Parameter 6, two consecutive aggregate gradations on one sieve) are outside Range 1 or Range 2 tolerance limits the mixture is considered out-of-specification and will be rejected. If a parameter is outside of Range 1 tolerance limits and the second consecutive test shows that the parameter is outside of Range 2, then it will be considered to be a Range 1 out-of-specification. If, for any one mixture, two consecutive tests do not meet the minimum requirements for crushed particle content specified in the project documents, the portion of the mixture with insufficient crushed particle content will be considered out-of-specification and will be rejected.

The quantity of material to be rejected is defined as the material produced from the time the first out-of-specification sample was taken until the time the sample leading to the first in-specification test was taken.

If out-of-specification mixtures are placed in a pavement, the Contractor has 4 calendar days from receipt of the acceptance test results to notify the Engineer, in writing, that dispute resolution testing is requested. The Contractor’s QC test results for the corresponding QA test results must result in an overall payment greater than QA test results, otherwise the QA tests will not be allowed to be disputed. The Engineer has 4 calendar days to send the dispute resolution sample to the MDOT Central Laboratory once dispute resolution testing is requested. The remaining 10,000 gram portion of the field samples (split samples) will be sent to the Central Laboratory to complete all Dispute Resolution testing and return test results to the Engineer, who will provide them to the Contractor, within 13 calendar days upon receiving the Dispute Resolution samples. The Contractor may only take pavement cores if approved in writing by the Engineer. If the Central Laboratory test results do not confirm the original field test results, then no price adjustments will be made for the mixture involved.

If the Central Laboratory test results confirm the original test results and, if in the Engineer’s judgment, the mixture warrants removal, the Contractor shall remove and replace the rejected (out-of-specification) mixture, at the Contractor’s expense, with a mixture meeting the specification requirements. These costs shall be deemed to include all costs associated with the material removal and replacement including, but not limited to; costs associated with re-mobilization of labor and equipment; traffic control; removal and disposal of the rejected material; transportation costs to provide material meeting the requirements of the specification; and, any other cost associated with the work. Contract time shall continue during the period of time that the rejected material is investigated and re-tested, as well as, during the removal and replacement operations.

If the Central Laboratory test results confirm the original test results and, if in the Engineer’s judgment, the mixture can remain in place, the base and/or unit price for the rejected (out-of-specification) mixture will be decreased as described in the Section G., “Price Adjustments.”

If no field extractions are performed on a given day because the quantity being placed is less than 100 tons, and if there is reason to believe that the mixture contains material parameters that exceed Range 2

tolerances, or if the crushed particle content is less than the established criteria, a price adjustment may also be applied, or removal may be required, based on extraction, gradation, and volumetric tests performed by the Engineer from pavement cores following the procedures outlined herein.

**G. PRICE ADJUSTMENTS**

Base Price. Price established by the Department to be used in calculating incentives and adjustments to pay items and shown in the contract.

The quantity of material receiving a price adjustment is defined as the material produced from the time the first out-of-specification sample was taken until the time the sample leading to the first in-specification test was taken.

The price adjustments will be determined by the Engineer from the combination of sample test result parameters of the out-of-specification (rejected) material that create the largest total price adjustment for the material. The price adjustments shall be determined based on Tables 3 and 4. The Engineer is not obligated to accept a price adjustment for out-of-specification (rejected) material that exceeds Range 2 limits in lieu of requiring the material to be removed and replaced at the Contractor’s expense in accordance with Section F, Rejected Mixtures.

In all cases, when penalties are assessed, the penalty applies to each parameter, up to two parameters, that is out of specification.

**Table 3: Penalty Per Parameter**

Mixture Parameter out-of-Specification per Acceptance Tests	Mixture Parameter out-of-Specification per Dispute Resolution Test Lab	Price Adjustment per Parameter
NO	N/A	None
YES	NO	None
	YES	Outside Range 1 but not Range 2: decrease by 10%
		Outside Range 2: decrease by 25%

**Table 4  
Calculating Total Price Adjustment**

Cost Adjustment as a Sum of the Highest Parameter Penalties		
Number of Samples with Parameters Out-of-Specification	Range(s) Outside of Tolerance Limits of Table 1 per Parameter	Total Price Adjustment
One	Range 1	10%
	Range 2	25%



Two	Range 1 & Range 1	20%
	Range 1 & Range 2	35%
	Range 2 & Range 2	50%
Three or more	Range 1, Range 1 & Range 1	20%
	Range 1, Range 1 & Range 2	35%
	Range 1, Range 2 & Range 2	50%
	Range 2, Range 2 & Range 2	50%

Each parameter of Table 1 is evaluated with the total price adjustment applied to the base and/or unit price based on a sum of the two parameter penalties resulting in the highest total price adjustment in accordance with Table 4. For example, if three parameters are out-of-specification, with two parameters outside Range 1 of Table 1 tolerance limits, but within Range 2 of Table 1 limits and one parameter outside of Range 2 of Table 1 tolerance limits and the Engineer approves leaving the mixture in place, the total price adjustment for that quantity of material is 35 percent.

If acceptance tests, as described in Section e. of this special provision, show that a Table 1 mixture parameter exceeds the Range 1, but not the Range 2, tolerance limits, that mixture parameter will be subject to a 10 percent penalty. The 10 percent penalty will be assessed based on the acceptance tests only unless the Contractor requests that the 10,000 gram sample part retained for possible dispute resolution testing be tested. The Contractor has 4 calendar days from receipt of the acceptance test results to notify the Engineer, in writing, that dispute resolution testing is requested. The Contractor's QC test results for the corresponding QA test results must result in an overall payment greater than QA test results, otherwise the QA tests will not be allowed to be disputed. The Engineer has 4 calendar days to send the dispute resolution sample to the MDOT Central Laboratory and the resultant dispute test results will be used to determine the penalty per parameter, if any. If the dispute testing results show that the mixture parameter is out-of-specification, the Contractor will pay for the cost of the dispute resolution testing and the contract unit and/or base price for the material will be adjusted, based on all test result parameters from the dispute tests, as shown in Table 3 and Table 4. If the dispute test results do not confirm the mixture parameter is out-of-specification, then the Local Agency will pay for the cost of the dispute resolution testing and no price adjustment is required.

If acceptance tests, as described in section e. of this special provision, show that a Table 1 mixture parameter exceeds the Range 2 tolerance limits, the 10,000 gram sample part retained for possible dispute resolution testing will be sent, within 4 calendar days, to the MDOT Central Laboratory for further testing. The MDOT Central Laboratory's test results will be used to determine the penalty per mixture parameter, if any. If the MDOT Central Laboratory's results do not confirm the mixture parameter is out-of-specification, then no price adjustment is required. If the MDOT Central Laboratory's results show that the mixture is out-of-specification, and the Engineer approves leaving the out-of-specification mixture in place, the contract unit and/or base price for the material will be adjusted, based on all parameters, as shown in Table 3 and Table 4.

In the case that the Contractor disputes the results of the test of the second sample obtained for a particular day of production, the test turn-around time frames given would apply to the second test and there would be no time frame on the first test.

## **H. MEASUREMENT AND PAYMENT**

The completed work, as described herein, will be measured and paid for using applicable pay items as described in subsection 501.04 of the Standard Specifications for Construction, or the contract, except as modified in Section G. Price Adjustments.

# **DETAILED SPECIFICATION FOR HMA APPLICATION ESTIMATE**

## **DESCRIPTION**

This work shall consist of furnishing and placing (HMA) hot mix asphalt on the prepared surfaces in accordance with the details shown on the plans and as specified in Section 501 of the Michigan Department of Transportation Standard Specifications for Construction, 2012 Edition with the exceptions and additions specified herein.

## **MATERIALS**

HMA (Mainline):

The HMA, LVSP used for top course shall have a yield of 220 pounds per square yard with a PG 58-28 binder. The HMA, LVSP used for top course shall have an AWI = 260 minimum.

The HMA, LVSP used for leveling course shall have a yield of 220 pounds per square yard with a PG 58-28 binder.

HMA Approach:

The HMA, LVSP used for the top course of HMA Approach shall have a yield of 220 pounds per square yard with a PG 58-28 binder. The HMA, LVSP used for the top course of HMA Approach shall have an AWI = 260 minimum.

The HMA, LVSP used for leveling course of HMA Approach shall have a yield of 220 pounds per square yard with a PG 58-28 binder.

Hand Patching:

The HMA, LVSP used for Hand Patching shall have a yield of 440 pounds per square yard with a PG 58-28 binder. The HMA, LVSP used for Hand Patching shall have an AWI = 260 minimum.

## **CONSTRUCTION METHOD**

A bond coat shall be applied before each lift of HMA mixture is placed. The rate of application shall be 0.05 to 0.15 gallons per square yard.

## **MEASUREMENT AND PAYMENT**

Measurement shall be based on load weight tickets from a certified scale and accepted at the job site by a City agent.

Payment for HMA (Mainline) shall include all labor, equipment and materials to complete this work.

Payment for Hand Patching shall include all labor, equipment and materials to complete this work.

**DETAILED SPECIFICATION  
FOR  
PROJECT DOCUMENTATION SUBMITTAL COMPLIANCE**

**DESCRIPTION**

This work consists of submitting all required project documentation to the Engineer within 45 calendar days from the latest Open to Traffic or Final Acceptance of the punch list work date, whichever comes first. Failure by the Contractor to meet this deadline shall result in the creation of a negative adjustment to the contract for failure to submit final project documentation as supplied by the Michigan Department of Transportation via their latest construction procedures and documentation manual. The time requirement may be extended if needed for claim or dispute issues. The Contractor shall promptly make these requests in writing to the Engineer. The Contractor shall be assessed \$250.00 for each calendar day that project documentation is not submitted after the aforementioned 45 day period. The duration related to the negative adjustment shall include all calendar days until all required project documentation has been submitted by the Contractor and approved by the Engineer.

**MATERIALS**

None specified.

**CONSTRUCTION METHODS**

None specified.

**MEASUREMENT AND PAYMENT**

The Engineer shall assess a negative adjustment to the contract based on the total number of calendar days the Contractor fails to submit final required project documentation including, but not limited to; progress schedule; subcontracts; shop drawings; certifications; certified payrolls; material source lists (MSLs); and the like.

**DETAILED SPECIFICATION  
FOR  
IN-SITU SOILS AND REMOVAL AND DISPOSAL OF CONTAMINATED SOILS**

**DESCRIPTION**

This Detailed Specification governs the classification of existing in-situ soils that can be encountered on the project site and the proper management and disposal of contaminated soils that may be encountered during the performance of the work of the project.

**EXISTING IN-SITU SOILS**

The Contractor shall be aware that soils within the City of Ann Arbor and Washtenaw County contain levels of naturally-occurring, regulated, elemental metals. The City of Ann Arbor has completed testing on numerous projects and levels of these naturally-occurring, regulated, elemental metals that may be encountered within the City of Ann Arbor and have found that they generally correspond to concentrations presented in the 2005 State of Michigan Background Soil Survey approved by the Michigan Department of Environment, Great Lakes, and Energy (EGLE) on October 4, 2019 for the Huron-Erie glacial Lobe.

All excavated material generated on the project shall become the property of the Contractor. Any excavated material that cannot be incorporated into the project work, in accordance with the material requirements of the work being performed, must be properly disposed of off-site by the Contractor. Consequently, excavated soils that do not exhibit odors, discoloration, or other indications of contamination, and meet the definition of an inert material in accordance with Part 115 Solid Waste Management of the Michigan Natural Resources and Environmental Protection Public Act 451 of 1994 (MNREPA Act 451), are not required to be disposed of in a landfill. These soils shall be disposed of by the Contractor by the method of their choice. The City of Ann Arbor suggests a disposal method that minimizes future human contact with the soil or the soil's contact with a water course or ground water sources, due to the possibility of elevated concentrations of naturally-occurring, regulated, elemental metals. The Contractor shall be responsible for any disposal or relocation methods that they chose to employ in the disposal of these soils.

The Contractor's submittal of a bid for this project shall be considered prima facie evidence that they have considered these facts and have included all necessary resources to perform all work of this project and to properly dispose of excavated soils from this project off-site.

**CONTAMINATED SOIL**

If the Contractor encounters soil suspected of containing contaminated constituents other than those of naturally-occurring, regulated, elemental metals it must be tested and classified prior to transport and disposal in accordance with EGLE Waste Characterization Guidance. Contaminated soil characterized as non-hazardous or hazardous may not be reused on-site within the project area. Non-hazardous, non-Resource Conservation and Recovery Act (RCRA) contaminated material shall be managed in accordance with Part 201 Environmental Remediation of the MNREPA Act 451. RCRA hazardous material shall be managed in accordance with Part 111 Hazardous Management of the MNREPA Act 451.

Soils containing elevated levels of naturally-occurring, regulated, elemental metals that are determined to be above EGLE-regulated background levels are excluded from the definition of "Contaminated Soil." During the performance of work on a project, if such soils are found or determined to exist after a course of testing and characterization, the off-site disposal of those soils shall not be paid.

Contaminated soil shall be placed in a vehicle equipped to carry the class of the material on public roads to the disposal site in accordance with applicable federal, state, or local regulations applicable to such soil, whether it is non-hazardous or hazardous.

### **SAMPLING AND ANALYSIS OF CONTAMINATED SOIL**

The Contractor shall be responsible for all sampling and analysis required for the disposal of contaminated material. Refer to EGLE Waste Characterization Guidance for guidance on the type of analysis required.

If the results of the analysis show the material to be non-hazardous or hazardous as defined by Part 111, of the Natural Resources and Environmental Act, Act 451, P.A. 1994, the Engineer shall be notified immediately. The material shall then be disposed of at a licensed Type I or Type II landfill as required by the applicable EGLE guidance.

### **DISPOSAL AND METHOD OF CONSTRUCTION**

This work shall be performed in accordance with Sections 104.07.B, 107.01, 204 and 205 of the MDOT 2012 Standard Specifications for Construction, except as modified herein or as directed by the Engineer.

The Contractor shall have all manifests signed by its representative, the Engineer's representative, the authorized representative of the waste hauler and the waste disposal facility.

### **EXCAVATION OF CONTAMINATED SOIL**

This work shall be performed in accordance with Sections 104.07.B, 107.01, 204 and 205 of the MDOT 2012 Standard Specifications for Construction, except as modified herein or as directed by the Engineer.

The Contractor shall have all manifests signed by its representative, the Engineer's representative, the authorized representative of the waste hauler and the waste disposal facility.

### **TEMPORARY STORAGE OF CONTAMINATED SOIL**

Excavated non-hazardous or hazardous contaminated soil which is to be temporarily stockpiled shall be placed on plastic sheeting or tarps having a minimum thickness of 6 mils or in trucks, roll-off boxes, or other containers, such that no liquid may escape from the containment. At the end of each work day, the contaminated material shall be covered securely with plastic sheeting of 6 mils thickness or greater.

Excavated hazardous or non-hazardous material shall be disposed of as soon as approval is received from the disposal site. In no case shall this material be stockpiled for longer than 30 days prior to disposal.

The Contractor is responsible for the necessary coordination such that his/her work activities are not adversely impacted by the stockpiling of contaminated soil. Stockpiled soil shall not impair sight distance or drainage. Time extensions shall not be granted by the Engineer for delays in receiving approval for the disposal of contaminated material at the appropriate landfill or other similar circumstances.

### **DISPOSAL OF NON-HAZARDOUS AND HAZARDOUS CONTAMINATED SOIL**

Disposal of non-hazardous contaminated soil shall be at a licensed Type II sanitary landfill. Disposal of hazardous contaminated soil shall be at a licensed Type I hazardous waste landfill. The Contractor shall submit at the pre-construction meeting the name of the Type II or Type I landfill to be used for disposal, the sampling and analysis requirements of the landfill, and verification that the use of the proposed landfill will meet the requirements of the County solid waste plan.

The disposal facility must be acceptable to the City of Ann Arbor and therefore approval must be obtained from the Engineer prior to commencing disposal operations. Prior to obtaining approval for the disposal from the City, the Contractor shall provide a copy of the laboratory analysis to the Engineer.

**MEASUREMENT AND PAYMENT.**

The completed work as described herein will be paid for at the contract unit price for the following contract items (pay items):

<u>Contract Item (Pay Item)</u>	<u>Pay Unit</u>
Non-Hazardous Contaminated Soil Handling and Disposal (LM).....	Cubic Yard
Hazardous Contaminated Soil Handling and Disposal (LM).....	Cubic Yard

Contaminated soil handling and disposal will be measured by volume in cubic yards, loose measure, as contained in the hauling unit. Under no circumstance will the Contractor be paid for quantities of this soil that have not received prior approval for payment by the Engineer and as measured and tracked by the Engineer and the Contractor. The Contractor will not be paid “standard amounts” that have been determined by the disposal facility; only measured volumes as computed by the Engineer will be paid. Prior to payment, the Engineer shall be given receipts from the disposal facility(s) for the number of cubic yards disposed of at that facility. Payment for this work shall include all costs for materials, labor and equipment needed for storage, loading, transportation, and disposal of the non-hazardous contaminated material. Disposal costs shall include any and all documentation required by the landfill. Payment for these items shall be the same, regardless of whether or not the Contractor temporarily stores the contaminated material; the Contractor shall not be paid for re-handling of the material due to construction staging, stockpiling, or other related activities.

Payment for excavation and handling of contaminated soil shall be included with the related items of work being performed when the material was encountered.

**DETAILED SPECIFICATION  
FOR  
ITEM #201 - PROJECT SUPERVISION, MAX \$15,000**

**DESCRIPTION**

The Contractor shall designate a full-time Project Supervisor to act as the Contractor's agent/representative, and to be responsible for scheduling and coordination of all subcontractors, suppliers, other governmental agencies, and all public and private utility companies.

The Project Supervisor shall not be an active crew member of the Contractor, shall not be an active member or employee of any subcontractor's work force, and shall not perform general or specialized labor tasks.

**The Project Supervisor shall work exclusively on this project, and shall put forth his/her full effort into the organization and coordination of the work of this project.**

Prior to the pre-construction meeting, the Contractor shall designate a proposed Project Supervisor by name, and shall furnish the City with a current, thorough, detailed summary of the proposed Project Supervisor's work history, outlining all previous supervisory experience on projects of a similar size and nature. The detailed work history shall include personal and professional references (names and phone numbers) of persons (previous owners or agents) who can attest to the qualifications and work history of the proposed Project Supervisor. Proposed candidates for Project Supervisor shall have a demonstrated ability to work harmoniously with the City, the public, subcontractors, and all other parties typically involved with work of this nature. The Supervising Professional will have the authority to reject a proposed Project Supervisor whom he/she considers unqualified.

The Project Supervisor shall be available 24 hours-per-day to provide proper supervision, coordination and scheduling of the project for the duration of the Contract. The Contractor shall furnish the City with telephone numbers of the Project Supervisor in order to provide 24 hour-per-day access during business and non-business hours, including weekends and holidays.

The Project Supervisor shall be equipped by the Contractor with a mobile telephone to provide the City with 24 hour-per-day access to him/her during daily construction activities, during transit to and from the construction site, and during all non-business hours including weekends and holidays.

The Project Supervisor shall be equipped with assistants as necessary to provide project supervision as specified herein, and in accordance with the Contract.

**DUTIES AND RESPONSIBILITIES**

The Project Supervisor work harmoniously with the City, the public, subcontractors, and all other parties typically involved with work of this nature.

The Project Supervisor shall have a thorough, detailed understanding and working knowledge of all construction practices and methods specified elsewhere herein, as well as the handling, placement, testing and inspection of aggregates, aggregate products, HMA concrete, and portland cement concrete materials.

The Project Supervisor shall be responsible for all of the work of all of the Contractor's, subcontractors' and suppliers' work forces.

The Project Supervisor shall be responsible for proper and adequate maintenance (emissions, safety, and

general operation) of all of the Contractor's, subcontractors' and suppliers' equipment and vehicles.

The Project Supervisor shall be responsible for the legal, proper and safe parking/storage of all of the Contractor's, subcontractors' and suppliers' equipment, work vehicles, and employee's vehicles.

The Project Supervisor shall schedule and coordinate the work of all parties involved in the project, including utility companies, testing agencies, governmental agencies, all City departments (such as Utilities and Transportation), and City inspectors.

The Project Supervisor shall coordinate and schedule the work of any independent survey crews that may be retained by the City to witness and reset existing and new geographic/benchmark monuments. Failure to have existing monuments witnessed and reset may result in delays to the Contractor's work. Costs for such delays will be the Contractor's sole responsibility.

The Project Supervisor shall coordinate and schedule both Testing inspectors and City inspectors in a timely manner, to assure proper and timely testing and inspection of the work.

The Project Supervisor shall review the Inspector's Daily Reports (IDRs) for accuracy, and shall sign all IDRs on a daily basis as the representative of the Contractor. Items to be reviewed include descriptions, locations and measurements of quantities of work performed, workforce, equipment, and weather. The Project Supervisor shall also be responsible for its subcontractors' review and initialing of IDRs containing work items performed by each respective subcontractors.

The Project Supervisor shall submit to the Engineer, an updated, detailed schedule of the proposed work on a weekly basis, and an update of all proposed changes on a daily basis, all in accordance with the Detailed Specification for Project Schedule contained elsewhere herein.

The Project Supervisor shall schedule and chair a weekly progress meeting with the Engineer and all subcontractors to discuss the work. Upon the completion of each meeting, the Project Supervisor shall prepare and distribute, to all present, a written summary of the meeting's minutes. Those in attendance shall review the minutes and, if necessary, comment on any deficiencies or errors prior to or at the next scheduled progress meeting.

### **ADDITIONAL PERFORMANCE REQUIREMENTS**

If, in the sole opinion of the Supervising Professional, the Project Supervisor is not adequately performing the duties as outlined in this Detailed Specification, the following system of notices will be given to the contractor with the associated penalties:

First Notice – A warning will be issued in writing to the contractor detailing the deficiencies in the Project Supervision. The contractor must respond within 7 calendar days in writing with a plan to correct the stated deficiencies. Failure to respond within 7 calendar days will result in the issuing of a second notice.

Second Notice – A second warning will be issued in writing to the contractor further detailing the deficiencies in the Project Supervision. The contractor must respond within 7 calendar days in writing with a plan to correct the stated deficiencies. Failure to respond within 7 calendar days will result in the issuing of a third notice. A deduction of 10% will be made from the original Project Supervision contract amount. At this time, the City reserves the right to meet with personnel with the necessary authority within the Contractor's organization to discuss the deficiencies in the Project Supervision.

Third Notice – An additional deduction of 25% will be made from the original Project Supervision



contract amount, and the Project Supervisor shall be removed from the project, and replaced immediately with another individual to be approved by the Supervising Professional.

Should, in the sole opinion of the Supervising Professional, the Project Supervisor fail to perform his/her duties and responsibilities as described herein to such a degree that the successful completion of the project is put in jeopardy, the above system of notices may be foregone, and the Contractor shall immediately replace the Project Supervisor upon receipt of written notice. Failure to provide adequate project supervision, as determined by the Engineer, shall be considered basis for the Supervising Professional to suspend work without extension of contract time or additional compensation.

#### MEASUREMENT AND PAYMENT

This item of work will be paid for on a pro rata basis at the time of each progress payment. Measurement will be based on the ratio between work completed during the payment period and the total contract amount. When all of the work of this Contract has been completed, the measurement of this item shall be 1.0 Lump Sum, minus any deductions incurred for inadequate performance as described herein. This amount will not be increased for any reason, including extensions of time, extras, and/or additional work.

The completed work as measured for this item of work will be paid for at the Contract Unit Price for the following Contract (Pay) Item:

**PAY ITEM**

**PAY UNIT**

Project Supervision, Max \$15,000

Lump Sum

The unit price for this item of work shall include all labor, material, and equipment costs to perform all the work specified in the Standard Specifications and as modified by this Detailed Specification.

**DETAILED SPECIFICATION  
FOR  
ITEM #202 – GENERAL CONDITIONS, MAX. \$30,000**

**DESCRIPTION**

This item shall include all work described and required by the Plans and Specifications for which no item of work is listed in the Bid Form, including but not limited to:

- Coordination of, and cooperation with, other contractors, agencies, departments, and utilities
- Protection and maintenance of Utilities
- Placing, maintaining, and removing all soil erosion and sedimentation controls (as specified herein or as shown on project plans)
- Maintaining drainage
- Maintaining driveway drive openings, sidewalks, bike paths, mail deliveries, and solid waste/recycle pick-ups. This includes the placement and maintenance of gravel in driveway openings as directed by the Engineer
- Using quantities of dust palliative, maintenance aggregate, and hot patching mixture for use as temporary base, surfacing, and dust control at utility crossings, side roads and driveways.
- Storing all materials and equipment off lawn areas
- Site clean-up
- Coordination efforts to furnish various HMA mixtures as directed by the Engineer
- Coordination efforts to furnish and operate various-size vehicles/equipment as directed by the Engineer
- Furnishing and operating vacuum-type street cleaning equipment a minimum of once per week or more frequently as directed by the Engineer
- Furnishing and operating vacuum-type utility structure cleaning equipment
- Furnishing and operating both vibratory plate and pneumatic-type (“pogo-stick”) compactors
- Furnishing and operating a backhoe during all work activities
- Furnishing and operating a jackhammer and air compressor during all work activities
- Noise and dust control
- Mobilization(s) and demobilization(s)
- Furnishing submittals and certifications for materials and supplies
- Disposing of excavated materials and debris
- Removal of shrubs, brush, trees, and stumps less than 8” diameter as directed by Engineer
- Trimming of trees to accommodate intersection sight distance as shown on plans and directed by Engineer.
- Fencing to protect excavations over one foot (1’) in depth during non-work hours or as directed by the Engineer. The fencing must be a minimum of 36” high, be constructed of orange HDPE material, and reasonably secured to prevent access.

- All miscellaneous and incidental items such as overhead, insurance, and permits.
- Meeting all requirements relating to Debarment Certification, Davis Bacon Act, and Disadvantaged Business Enterprise, and providing the necessary documentation.

**MEASUREMENT AND PAYMENT**

This item of work will be paid for on a pro rata basis at the time of each progress payment. Measurement will be based on the ratio between work completed during the payment period and the total contract amount. When all of the work of this Contract has been completed, the measurement of this item shall be 1.0 Lump Sum. This amount will not be increased for any reason, including extensions of time, extras, and/or additional work.

The completed work as measured for this item of work will be paid for at the Contract Unit Price for the following Contract (Pay) Item:

**PAY ITEM**

General Conditions, Max. \$30,000

**PAY UNIT**

Lump Sum

The unit price for this item of work shall include all labor, material, and equipment costs to perform all the work specified in the Standard Specifications and as modified by this Detailed Specification.

## **DETAILED SPECIFICATION FOR ITEM #203 – DIGITAL AUDIO VISUAL COVERAGE**

### **DESCRIPTION**

This work shall include providing a recording of the physical, structural, and aesthetic conditions of the construction site and adjacent areas as provided herein.

The Audio-Visual recording shall be:

1. Of professional quality, providing a clear and accurate Audio and Visual record of existing conditions.
2. Prepared prior to the preconstruction meeting.
3. Furnished to the Engineer a minimum of two (2) days prior to bringing any materials or equipment within the areas described in this special provision.
4. Furnished to the Engineer either at, or prior to, the preconstruction meeting.
5. Carried-out under the supervision of the Engineer.

The Contractor shall furnish two (2) copies of the completed recording to the Engineer at, or prior to, the preconstruction meeting. An index of the recording, which will enable any area of the project to be easily found on the recording, shall be included. The Contractor shall retain a third copy of the recording for his/her own use.

Any portion of the recording determined by the Engineer to be unacceptable for the documentation of existing conditions shall be recorded again, at the Contractor's sole expense, and submitted to the Engineer prior to mobilizing onto the site.

### **PRODUCTION**

The Audio-Visual recording shall be completed in accordance with the following minimum requirements:

1. DVD Format / No Editing.- The Audio-Visual recording shall be performed using equipment that allows Audio and Visual information to be recorded simultaneously and in color. The recording shall be provided on compact discs in DVD format. The quality of the recording shall be equal to or better than the standard in the industry. The recording shall not be edited.
2. Perspective / Speed / Pan / Zoom.- To ensure proper perspective, the distance from the ground to the camera lens shall not be less than 12 feet and the recording must proceed in the general direction of travel at a speed not to exceed 5 miles per hour. Pan and zoom rates shall be controlled sufficiently so that playback will ensure quality of the object viewed.
3. Display.- The recording equipment shall have transparent time, date stamp and digital annotation capabilities. The final copies of the recording shall continuously and simultaneously display the time (hours:minutes:seconds) and the date (month/date/year) in the upper left-hand corner of the frame. Accurate project stationing shall be included in the lower half of the frame in standard station format (i.e. 1+00). Below the stationing periodic information is to be shown, including project name, name of area shown, direction of travel, viewing direction, etc.

On streets or in areas where there is no project stationing, assumed stationing shall be used, starting with 0+00 and progressing from west to east or from south to north.

4. Audio Commentary / Visual Features. Locations relative to project limits and landmarks must be

identified by both audio and video means at intervals no longer than 100 feet along the recording route. Additional audio commentary shall be provided as necessary during the recording to describe streets, buildings, landmarks, and other details, which will enhance the record of existing conditions.

5. **Visibility / Ground Cover.**- The recording shall be performed during a time of good visibility. The recording shall not be performed during periods of precipitation or when snow, leaves, or other natural debris obstruct the area being recorded.

## **COVERAGE**

The Audio-Visual recording coverage shall include the following:

1. **General Criteria.**- This general criteria shall apply to all recording and shall include all areas where construction activities will take place or where construction vehicles or equipment will be operated or parked and/or where materials will be stored or through which they will be transported. The recording shall extend an additional 50 feet outside of all areas. The recording shall include all significant, existing man-made and natural features such as driveways, sidewalks, utility covers, utility markers, utility poles, other utility features, traffic signal structures and features, public signs, private signs, fences, landscaping, trees, shrubs, other vegetation, and other similar or significant features.
2. **Private Property.**- Record all private property that may be utilized by the Contractor in conjunction with this project. These project areas must be disclosed by the Contractor prior to using them for the work of this project.
3. **Road Construction Area.**- The recording coverage shall:
  - a. Extend to 50 feet outside of the right-of-way and easements area as shown on the plans.
  - b. Extend 50 feet outside the construction limits on all streets, including side streets.Both sides of each street shall be recorded separately.
4. **Detour Route / Maintenance of Traffic Areas.** The entire detour route and maintenance of traffic areas shall be recorded as indicated in this special provision except as follows:
  - a. The recording must proceed in the general direction of travel at a speed not exceeding 25 miles per hour.
  - b. The coverage area shall include the street and not go beyond the curb except in areas where there is a fair possibility that the detoured traffic will drive over the curb, such as at intersections.
  - c. The recording shall focus in particular at sidewalk ramps and other features likely to have been damaged or likely to be damaged as a result of existing traffic, temporary detoured traffic and or construction traffic. In these areas, recording may need to proceed much more slowly.

Only the side of street with the detoured traffic must be recorded. However, the Contractor is advised that portions of the detour routes may operate in opposite directions at different times. In these cases, both sides of the street shall be recorded separately.

5. **Private Property bordering the project limits or work areas.** Record all areas bordering the project where work is scheduled to occur or where construction traffic could damage the private property. This is to including buildings, driveways, decks, landscaping, trees, and all other similar features.
6. **Other Areas.** The Contractor shall record at his sole expense other areas where, in his/her opinion, the establishment of a record of existing conditions is warranted. The Contractor shall notify the

Engineer in writing of such areas.

The Engineer may direct the recording of other minor areas not specified herein at the Contractor's sole expense.

**AUDIOVISUAL RECORDING SERVICES**

The following companies are known to be capable of providing the recording services required by this special provision and shall be utilized, unless the Contractor receives prior written approval from the Engineer to utilize another company of comparable or superior qualifications.

1. Construction Video Media
2. Midwest Company
3. Topo Video, Inc.
4. Video Media Corp.
5. Paradigm 2000, Inc.
6. Finishing Touch Photo and Video

**MEASUREMENT AND PAYMENT**

The completed work shall be paid for at the contract unit price for the following contract pay item:

<b><u>PAY ITEM</u></b>	<b><u>PAY UNIT</u></b>
Digital Audio Visual Coverage	Lump Sum

“Digital Audio Visual Coverage” shall include all labor, equipment, and materials required to perform the recording and to provide the finished recording the Engineer.

Payment will be made for “Digital Audio Visual Coverage” following the review and acceptance of the recording by the Engineer. Within 21 days following the receipt of the recording, the Engineer will either accept it and authorize payment, or require that any discrepancies in the recording be addressed prior to making payment.

**DETAILED SPECIFICATION  
FOR  
ITEM #204 - MINOR TRAFFIC DEVICES, MAX. \$20,000**

**DESCRIPTION**

The work of Temporary Traffic Devices shall consist of protecting and maintaining vehicular and pedestrian traffic as shown on the plans, in the Maintenance of Traffic specification, and as directed by the Engineer, in accordance with Sections 103.05, 103.06, and 812 of the 2012 MDOT Standard Specifications for Construction; Part 6 of the Michigan Manual of Uniform Traffic Control Devices, Latest Revised Edition (MMUTCD); and the City Standard Specifications, except as modified herein. These devices include, but not limited to, advance, regulatory, and warning signs; barricades and channeling devices at intersecting streets on which traffic is to be maintained; barricades at the ends of the project and at right-of-way lines of intersecting streets; changeable message signs; lighted arrow boards; sign/signal covers and pavement marking cover tape for construction operations.

The work of Minor Traffic Devices shall include, but not be limited to:

- The furnishing and operating of miscellaneous signs, warning devices, flag-persons, and cones;
- The operation of additional signs furnished by the City;
- Furnishing and installing meter bags;
- Coordinating with the City to have meter heads removed and reinstalled;
- Maintaining pedestrian traffic;
- Temporarily covering traffic controls;
- Temporarily covering existing signs as directed;
- Temporarily covering existing pavement markings and symbols as directed;
- Any and all other miscellaneous and/or incidental items which are necessary to properly perform the work.

The Contractor shall maintain vehicular and pedestrian traffic during the work by the use of flag-persons, channelizing devices, and signs as necessary, as directed by the Engineer, and in accordance with MMUTCD. Typical applications for maintaining pedestrian traffic in accordance with the MMUTCD are included in this detailed specification.

**MATERIALS, EQUIPMENT, AND CONSTRUCTION METHODS**

**General**

Materials and equipment shall meet the requirements specified in the above-designated sections of the MDOT Standard Specifications.

All temporary traffic/pedestrian control devices furnished by the Contractor shall remain the property of the Contractor. The City shall not be responsible for stolen or damaged signs, barricades, barricade lights or other traffic maintenance items. The Contractor shall replace missing traffic control devices immediately, at no additional cost to the City.

All existing signs, and signs erected by the City of Ann Arbor on this project shall be preserved, protected, and maintained by the Contractor. Existing City owned signs which are damaged by the Contractor during the work will be repaired by the City at the Contractor's expense.

The Contractor shall temporarily cover conflicting traffic and/or parking signs when directed by the Engineer.

When traffic control devices have been damaged by, or due to, the negligence of the Contractor, his subcontractors or material suppliers, the traffic control devices shall be replaced at the Contractor's expense.

Lighted Plastic Drums; Barricades; Temporary Signs; Portable Changeable Message Signs; Lighted Arrow Boards; Pavement Marking Cover Tape; Temporary Pavement Markings

The Contractor shall furnish and operate these items as directed by the Engineer.

Approximate quantities for these items are 3 Portable Changeable Message Signs, 2000 ft Black Pavement Marking Tape, Type R, 750 sft Temporary Signs, Type B, 48 Type III Barricades, 10 Type II Barricades, 150 Channelizing Devices, and 150 Type II Lighted Plastic Drums.

Traffic control devices meeting current MDOT and MMUTCD specifications shall be used on this project.

Lighted plastic drums shall be sufficiently ballasted to minimize tipping.

Type I and III barricades shall have standard orange-and-white stripes on both sides of the barricade.

Sufficient signs shall be provided by the Contractor to ensure the safety of the workers and the general public in accordance with the current MMUTCD.

"Road Work Ahead" warning signs shall be placed, as indicated on the Plans, or as directed by the Engineer, prior to the start of work, regardless of the nature, magnitude or duration of the work.

Removable black pavement marking cover tape shall be used to cover conflicting pavement markings as directed by the Engineer.

Temporary pavement markings may be used within transition areas as directed by the Engineer and shall be removable.

**MEASUREMENT AND PAYMENT**

This item of work will be paid for on a pro rata basis at the time of each progress payment. Measurement will be based on the ratio between work completed during the payment period and the total contract amount. When all of the work of this Contract has been completed, the measurement of this item shall be 1.0 Lump Sum.

The completed work as measured for this item of work will be paid for at the Contract Unit Price for the following Contract (Pay) Item:

**PAY ITEM**

Minor Traffic Devices, Max \$20,000

**PAY UNIT**

Lump Sum

The unit price for this item of work shall include all labor, material, and equipment costs to perform all the work specified in the Standard Specifications and as modified by this Detailed Specification.



Figure 6H-28. Sidewalk Detour or Diversion (TA-28)

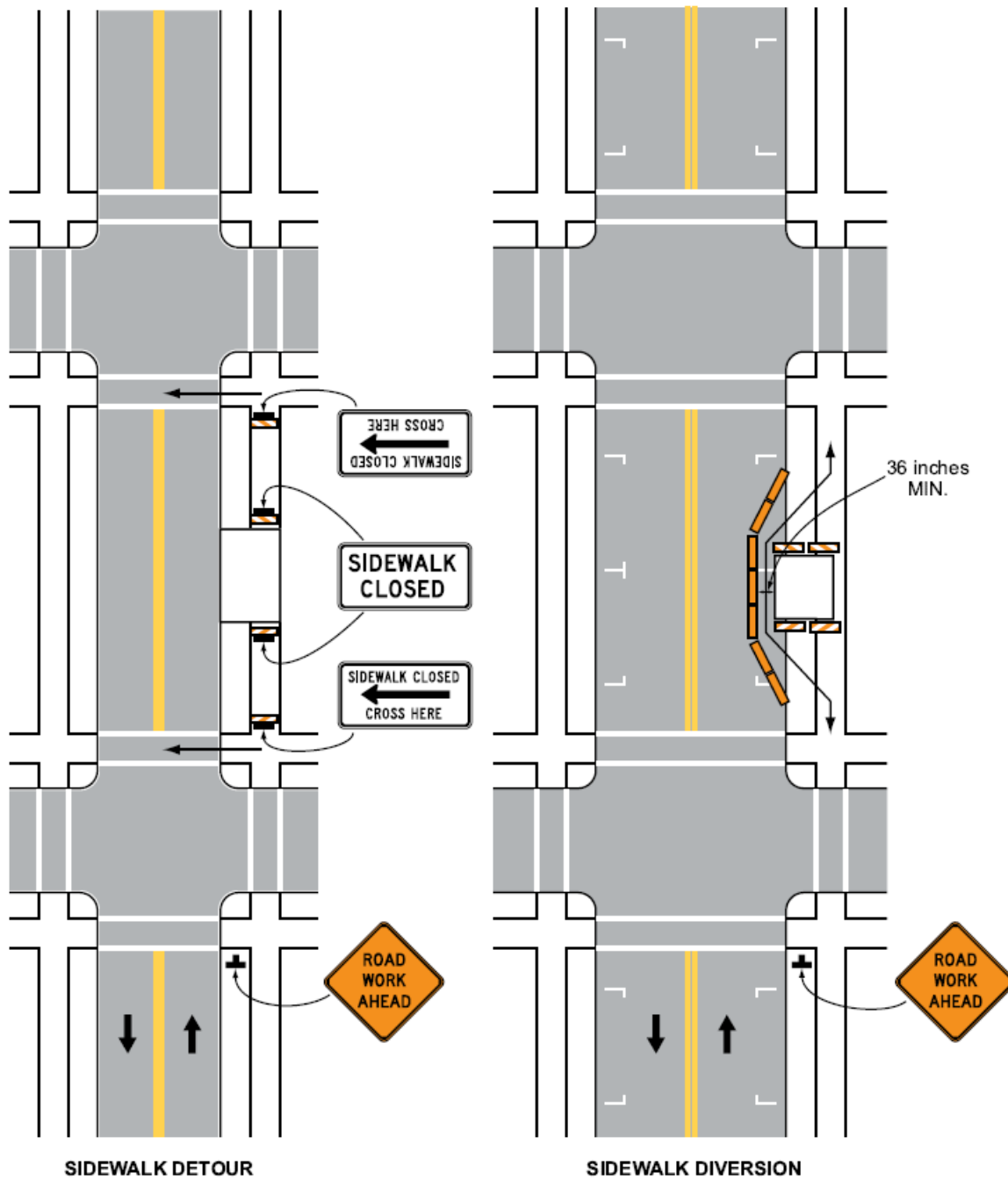

**Typical Application 28**

Note: See Tables 6H-2 and 6H-3 for the meaning of the symbols and/or letter codes used in this figure.

Figure 6H-29. Crosswalk Closures and Pedestrian Detours (TA-29)

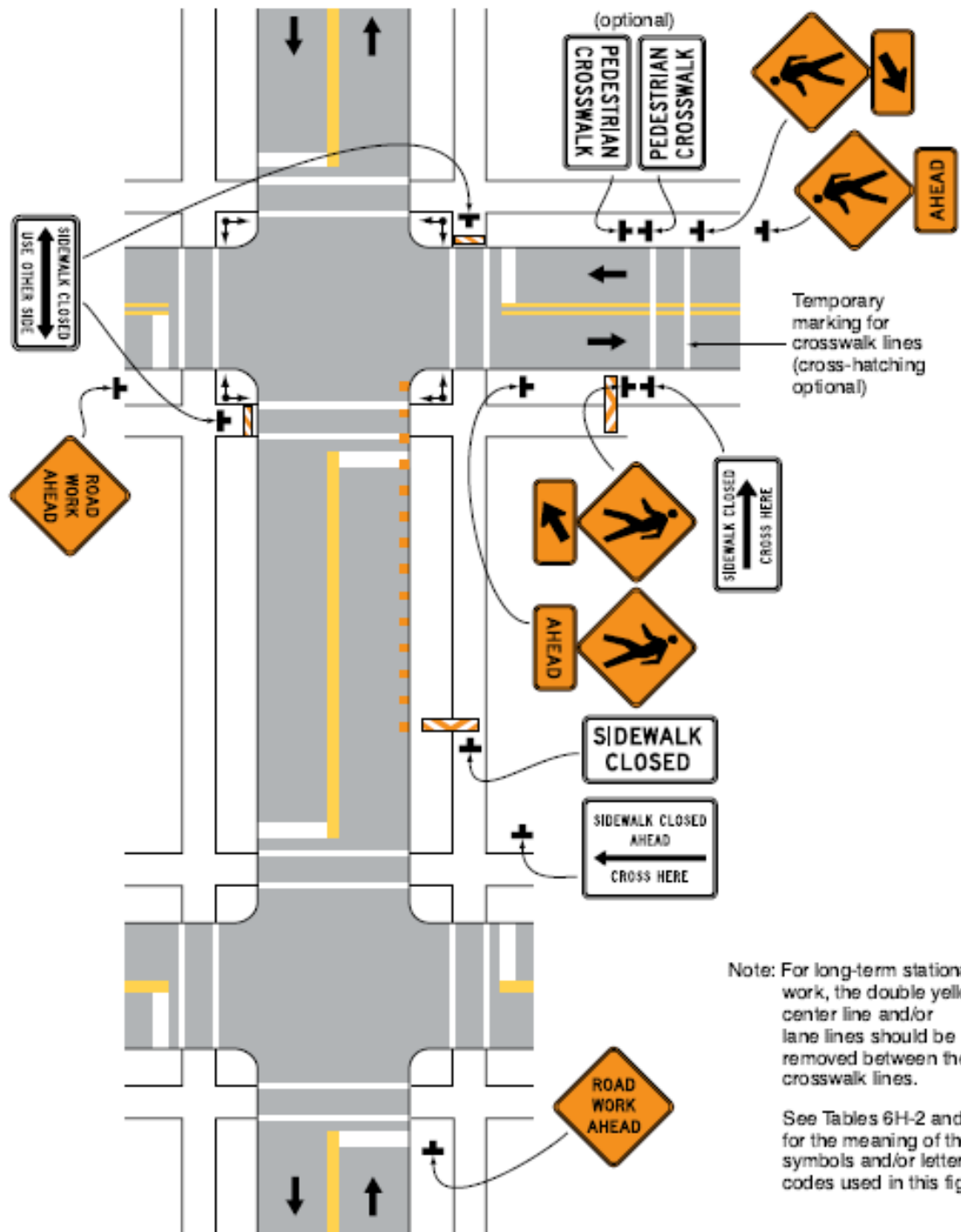

Note: For long-term stationary work, the double yellow center line and/or lane lines should be removed between the crosswalk lines.

See Tables 6H-2 and 6H-3 for the meaning of the symbols and/or letter codes used in this figure.

Typical Application 29

**DETAILED SPECIFICATION  
FOR  
ITEM #205 – CLEAN-UP AND RESTORATION, SPECIAL, MAX \$10,000**

**DESCRIPTION**

This item of work shall conform to Division IX, Section II, “Clean-Up & Restoration” of the Public Services Area Standard Specifications, except as specified herein.

This work shall include the removal of all surplus materials from the site including; but not limited to; tools, dirt, rubbish, construction debris, and excess excavated material. This work shall also include the restoration of all existing lawn areas, road surfaces, culverts, drives, and sidewalks disturbed by the work.

**CONSTRUCTION METHODS**

Cleanup and Restoration must be performed upon the completion of each stage of work, to prevent erosion, and not as one single operation at the completion of the entire project. Restoration work must be performed within one week of the placement of the wearing course for each street.

The Contractor shall restore all disturbed areas to better than or equal to their original condition.

**MEASUREMENT AND PAYMENT**

Measurement and payment for this item of work shall conform to Division IX, Section 2, “Clean-Up & Restoration” of the Public Services Area Standard Specifications except as modified herein.

The completed work for “Clean-Up & Restoration, Special, Max \$10,000” will be paid for on a lump sum (LS) basis. 80% of said lump sum shall be paid upon completion and approval of the site by the Engineer. By May 31<sup>st</sup> of the year following the completion of the project, the Engineer will inspect the seeded turf to ensure that the end product is well established; weed free, and in a growing and vibrant condition. If the Engineer determines that the restored areas meet the project requirements, the remaining 20% of the lump sum will be paid. If the Engineer determines that the restored areas do not meet the project requirements, the Contractor will continue with any and all measures necessary to meet the project requirements. All costs associated with the remedial measures shall be borne entirely by the Contractor.

**Pay Item**

Clean-Up & Restoration, Special, Max \$10,000

**Pay Unit**

Lump Sum

**DETAILED SPECIFICATION  
FOR  
ITEM #206 – “NO PARKING” SIGNS**

**DESCRIPTION**

This work shall consist of installing, maintaining and removing of "No Parking" signs and posts, as outlined herein and as referenced on the plans. "No Parking" signs shall be installed in accordance with the Public Services Department Standard Specifications and the most recent version of the Michigan Manual of Uniform Traffic Control Devices (MMUTCD).

**MATERIAL**

All materials for this work shall conform to the requirements of the Public Services Department Standard Specifications.

**CONSTRUCTION METHODS**

Prior to the commencement of any construction activity, the Contractor will be required to place "No Parking" signs where directed by the Engineer. The Contractor shall obtain a form for "Temporary Permission to Reserve Parking Lane for Work-Related Purposes" for each street from the City of Ann Arbor Engineering Unit. This form shall be submitted a minimum of five (5) days prior to the posting of "No Parking" signs. The issued permit must be printed and displayed on site at all times.

The City will furnish "No Parking" signs to the Contractor at no cost. The Contractor shall furnish the signposts and shall securely bolt the signs to the signposts as directed by the Engineer. After MISS DIG Clearance, the Contractor shall install the signposts at least two feet deep into the ground, and there shall be a minimum 6-foot and maximum 7-foot clearance maintained between the bottom of the sign and the ground. The signs are to be placed at 150-foot intervals (or as necessary) to eliminate parking in the construction area.

The installation of "No Parking" signs shall be in accordance with the permit. "No Parking" signs shall be installed by the Contractor, as directed by the Engineer, at least 48 hours prior to the proposed start-of-work/enforcement date. "No Parking" signs shall be returned to the City at the completion of the work. The cost of unreturned signs will be back-charged to the Contractor. "No Parking" signs shall be covered by the Contractor, thereby allowing on-street parking, whenever there is no work being performed for a period of time longer than 72 hours.

**MEASUREMENT AND PAYMENT**

The unit price for this item of work shall include all labor, material, and equipment costs to perform all the work specified in the Standard Specifications and as modified by this Detailed Specification.

"No Parking" signs will be measured as the maximum number installed on each street at any one time. The unit price includes the removal and return of "No Parking" signs to the City upon completion of the project. The Contractor shall be back-charged for the replacement costs for damaged or unreturned signs.

**PAY ITEM**

**PAY UNIT**

“No Parking” Signs

Each

**DETAILED SPECIFICATION  
FOR  
ITEM #207 – STUMP REMOVAL, 8” OR LARGER, MODIFIED**

**DESCRIPTION**

This work shall consist of removing existing stumps that are 8 inch or larger in diameter where indicated on the Plans, and as directed by the Engineer. This work shall include removing stumps, and roots from the ground, and disposing of all removed materials. All materials need to accomplish this work are included in this pay item. All work shall be done in accordance with the City of Ann Arbor Public Services Department Standard Specifications, Section 202 of the Michigan Department of Transportation (MDOT) Standard Specifications for Construction (2012 edition) and as directed by the Engineer.

**CONSTRUCTION METHODS**

The Construction Methods shall meet all requirements of the City of Ann Arbor Standard Specifications and MDOT Standard Specifications for Construction (2012 edition). As required, remove and dispose of stumps with a diameter of at least 8 inches. Stumps shall be removed using a stump grinder to a depth of at least 8 inches below final grade.

**MEASUREMENT AND PAYMENT**

This item shall be measured per stump removed and paid for on the basis of unit price each. The stump size will be determined by the average diameter of the stump trunk, measured to the nearest full inch, at a point 0.5 feet above the base of the stump at the ground line. Where more than one stump has grown from a common stump, each stump shall be measured as a separate stump. Stumps found to be less than 8 inches in diameter shall be removed under the pay item “General Conditions, Max \$30,000.’

The unit price for this item of work shall include all labor, material, and equipment costs to perform all the work specified in the Standard Specifications and as modified by this Detailed Specification.

**PAY ITEM**

Stump Removal, 8” or Larger, Modified

**PAY UNIT**

Each

# **DETAILED SPECIFICATION FOR ITEM #208 – TREE TRIMMING**

## **DESCRIPTION**

This work consists of providing all labor, equipment and materials necessary to cut, remove, and dispose of tree branches and canopy overhanging the proposed sidewalk up to ten feet in height as shown on the plans and as directed by the Engineer. All work must be in accordance with sections 201 and 202 of the 2012 Standard Specifications for Construction.

## **MATERIAL**

Provide all necessary materials required to perform described work.

## **CONSTRUCTION METHODS**

The work must be conducted in accordance with subsection 201.03 of the 2012 Standard Specifications for Construction. Trimming should be performed without endangering traffic and the general public, injuring other trees, and damaging structures or property.

The Engineer will establish environmental limits. All trees, shrubs, plants, grasses, and other vegetative materials shall remain, except as designated by the Engineer. Vegetation that is not designated for removal by the Engineer shall be protected. Repair or replace trees or shrubs damaged by Contractor operations at no additional cost to the Department.

Prior to beginning construction, trimming and pruning of encroaching vegetation (as determined by the Engineer) shall be completed.

Once all directed trimming and pruning is completed and accepted, no additional clearing, trimming, cutting, or pruning will be allowed unless approved, in writing, by the Engineer.

This work shall be done by a Contractor or subcontractor who is a qualified tree surgeon and a member of the National Arborist Association. The firm's or individual's name and qualifications shall be submitted at the preconstruction meeting for the Engineer's approval. A list of references and other clients shall be included with the qualifications statement. A written description of work methods and time schedules shall be submitted and approved in writing by the Engineer prior to work commencing.

Strict limits of disturbance will be defined and shall be adhered to.

Branches on trees or shrubs shall be removed as directed by the Engineer. All trimming shall be done by skilled workmen. All work shall be done according to the following requirements:

- (1) Pruning shall be done with proper, sharp, clean tools in such a manner as to preserve the natural character of the tree.
- (2) All final cuts shall leave no projections on or off the branch and shall not be cut so close as to eliminate the branch collar.
- (3) To avoid bark stripping, all branches 2 inches in diameter and larger shall be cut using the 3 cut method. These branches shall be lowered to the ground by proper ropes.

- (4) Tools used on trees known or found to be diseased, shall be disinfected with alcohol before they are used on other trees.
- (5) Structural weaknesses, decayed trunk or branches, or split crotches shall be reported to the Engineer.
- (6) Climbing spikes shall not be used on trees.

All trimmed brush, branches, limbs, and foliage shall become the property of the Contractor and shall be immediately removed and properly disposed of off-site.

**MEASUREMENT AND PAYMENT**

The completed work, as described, will be measured and paid for at the respective contract unit prices for the following respective pay items:

<b><u>PAY ITEM</u></b>	<b><u>PAY UNIT</u></b>
Tree Trimming	Each

Tree Trimming will be measured in place by the unit Each and paid for at the contract unit price per Each, which price shall be payment in full for all labor, equipment and materials necessary to accomplish this work for each tree trimmed.

Chipping, stockpiling mulch, and hauling and stockpiling limbs will not be paid for separately but shall be included in the work.

**DETAILED SPECIFICATION FOR  
ITEM #210 - REMOVE CONCRETE CURB OR CURB & GUTTER - ANY TYPE  
ITEM #211 - REMOVE CONCRETE SIDEWALK AND DRIVE - ANY  
THICKNESS**

**DESCRIPTION**

This work shall consist of removing concrete curb, gutter, curb and gutter, integral curb, sidewalk, sidewalk ramps, drive openings, and drives as shown on the Plans, as detailed in the Specifications, and as directed by the Engineer, in accordance with Section 204 of the 2012 edition of the MDOT Standard Specifications for Construction, except as specified herein, and as directed by the Engineer.

**CONSTRUCTION METHOD**

**The Contractor shall remove concrete curb, gutter, curb & gutter, integral curb, sidewalk, sidewalk ramps, drive openings, and drives, all regardless of the type and thickness, and all as shown on the Plans, as detailed in the Specifications, and as directed by the Engineer.**

Prior to the start of removals, the Engineer and Contractor together shall field measure all removals.

The Contractor shall perform full-depth saw cutting at removal limits, including those necessary to construct 2-foot wide City of Ann Arbor Type M drive openings, and including those necessary to provide for the partial removal of existing drive approaches as shown on the Plans, as directed by the Engineer, and as marked for removal. The Contractor shall cut steel reinforcement bars as directed by the Engineer at all areas of removal.

The Contractor shall remove, salvage, deliver to W. R. Wheeler Service Center (4251 Stone School Road, Ann Arbor, MI 48108), and neatly stack/stockpile all bricks, if present, as directed by the Engineer.

The Contractor shall excavate, cut, remove stumps, remove brush, grade, and trim as needed and as directed, and shall import, furnish, fill, place, grade, and compact granular material as needed to: construct new concrete items; to repair or replace existing concrete items; to relocate existing concrete items to their new specified/directed elevations/locations, including all necessary grading at elevation changes of curb and gutter, sidewalks and ramps; and at locations where existing concrete items are to be removed and turf is to be established in its place.

**The Contractor shall coordinate with the Urban Forestry and Natural Resources Planning Coordinator prior to the removal of any tree roots 2 inches or larger in size.**

At various times throughout the work, the Engineer may direct the Contractor to use smaller and/or lighter equipment, and to defer certain work tasks, in order to protect the grade and/or adjacent areas. The Contractor shall not be entitled to any additional compensation for the use of smaller equipment, lighter equipment, or work task deferral.

The Contractor shall re-shape, re-grade, and re-compact the existing roadbed materials to the cross-section(s) as indicated on the Plans, as detailed in the Specifications, and as directed by the Engineer. The Contractor shall use blade graders, maintainers, vibratory rollers, and/or other equipment as necessary, and as directed by the Engineer. The use of each specific piece of equipment is subject to the approval of the Engineer.

The Engineer may direct aggregate base materials to be either removed from or added to the job-site, to properly complete the work. Where the Engineer directs the addition of such materials, they shall be paid for as either the Item of Work: "21AA Limestone - C.I.P.", "Aggregate Base Course, 21AA - C.I.P." or "Sand Subbase Course, CL II - C.I.P.". Where the Engineer directs such materials to be removed, they will not be paid for separately, but shall be included in the appropriate concrete removal item.

Where existing concrete curb & gutter is to be replaced on a street with a concrete (or brick) base, the Engineer may direct the Contractor to remove a 1-to-2-foot wide, full-depth section of pavement and



pavement base from immediately in front of the curb & gutter. As part of this pavement/base removal, the Contractor shall perform additional (double) full-depth saw-cutting along the entire removal limits, and shall take sufficient care so as not to damage and/or disturb any adjacent pavement, pavement base, and/or any other site feature, all as directed by the Engineer. The removals shall be to a sufficient width and depth to allow for the placement and removal of the curb & gutter formwork. After the removal of the formwork, the Contractor shall replace the concrete base to its original thickness and elevation(s).

Excavated/removal areas shall be adequately protected with barricades or fencing at all times.

Removed or excavated materials which are not incorporated into the work shall become the property of the Contractor and shall be immediately removed and properly disposed of off-site. Removed or excavated materials may not be stockpiled overnight on, or adjacent to, the site.

Subbase or subgrade removed without authorization by the Engineer shall be replaced and compacted by the Contractor at the Contractor's expense, with materials specified by the Engineer.

The Contractor shall restore all disturbed areas to better than or equal to their original condition. This includes the placement and compaction of 4 inches of topsoil, followed by placement of grass seed, followed by the placement fertilizer and mulch blanket at all turf restoration locations, and at locations where concrete items are removed and turf is to be established. All restoration work and materials shall be in accordance with the Detailed Specifications "Clean-up & Restoration, Special".

### **MEASUREMENT AND PAYMENT**

Sidewalk ramp removal shall be measured and paid for as "Remove Concrete Sidewalk and Drive - Any Thickness".

Payment for saw cutting to create or modify Type M openings, and to allow for the partial removal of existing drives shall be included in the price of the item of work, "Remove Concrete Sidewalk & Drive - Any Thickness", and will not be paid for separately.

All saw-cutting required for removals shall be included in the appropriate item of work, and will not be paid for separately.

Restoration work, including backfilling, compacting, HMA patching adjacent to concrete items, topsoiling and seeding will not be paid for separately, but shall be included in the appropriate associated items of work.

Concrete removal items shall be field measured and paid for at the Contract Unit Prices for their respective Contract (Pay) Items as follows:

<b><u>PAY ITEM</u></b>	<b><u>PAY UNIT</u></b>
Remove Concrete Curb or Curb and Gutter - Any Type	Foot
Remove Concrete Sidewalk and Drive - Any Thickness	Square Feet

The unit prices for these items of work shall include all labor, material, and equipment costs to perform all the work specified in the Standard Specifications and as modified by this Detailed Specification.

**DETAILED SPECIFICATION  
FOR  
ITEM #212 COLD MILLING HMA SURFACE**

**DESCRIPTION**

This work consists of providing and placing permanent pavement markings in accordance with the Michigan Department of Transportation (MDOT) 2012 Standard Specifications for Construction, City of Ann Arbor Special Details, and as specified herein.

**MATERIALS**

Cold Milling will be the property of the Contractor, and shall be disposed of in accordance with subsection 104.07.D and subsection 204.03 of the Michigan Department of Transportation (MDOT) 2012 Standard Specifications for Construction.

**CONSTRUCTION METHODS**

The construction methods shall conform to section 501 of the MDOT 2012 Standard Specifications, the Plans, and as specified herein.

**MEASUREMENT AND PAYMENT**

Completed work, as described, will be measured and paid for at Contract Unit Prices for the following Contract (Pay) Items:

**PAY ITEMS**

**PAY UNIT**

Cold Milling HMA Surface

Syd

The unit prices for these items of work shall include all labor, material, and equipment costs to perform all the work specified in subsection 501.04.D of the MDOT 2012 Standard Specifications for Construction and as modified by this Detailed Specification.

## **DETAILED SPECIFICATION FOR ITEM #213 – HMA SURFACE REMOVE**

### **DESCRIPTION**

This work shall consist of removing asphalt drive openings and drives as shown on the Plans, as detailed in the Specifications, and as directed by the Engineer, in accordance with Section 501 of the 2012 edition of the MDOT Standard Specifications for Construction, except as specified herein, and as directed by the Engineer.

### **CONSTRUCTION METHOD**

**The Contractor shall remove asphalt drive openings and drives, all regardless of the thickness, and all as shown on the Plans, as detailed in the Specifications, and as directed by the Engineer.**

Prior to the start of removals, the Engineer and Contractor together shall field measure all removals.

The Contractor shall perform full-depth saw cutting at removal limits, as shown on the Plans, as directed by the Engineer, and as marked for removal.

At various times throughout the work, the Engineer may direct the Contractor to use smaller and/or lighter equipment, and to defer certain work tasks, in order to protect the grade and/or adjacent areas. The Contractor shall not be entitled to any additional compensation for the use of smaller equipment, lighter equipment, or work task deferral.

The Contractor shall re-shape, re-grade, and re-compact the existing driveway base materials to the cross-section(s) as indicated on the Plans, as detailed in the Specifications, and as directed by the Engineer. The Contractor shall use blade graders, maintainers, vibratory rollers, and/or other equipment as necessary, and as directed by the Engineer. The use of each specific piece of equipment is subject to the approval of the Engineer.

The Engineer may direct aggregate base materials to be either removed from or added to the job-site, to properly complete the work. Where the Engineer directs the addition of such materials, they shall be paid for as either the Item of Work: "21AA Limestone - C.I.P.", "Aggregate Base Course, 21AA - C.I.P." or "Sand Subbase Course, CL II - C.I.P.". Where the Engineer directs such materials to be removed, they will not be paid for separately, but shall be included in this item.

Excavated/removal areas shall be adequately protected with barricades or fencing at all times.

Removed or excavated materials which are not incorporated into the work shall become the property of the Contractor and shall be immediately removed and properly disposed of off-site. Removed or excavated materials may not be stockpiled overnight on, or adjacent to, the site.

Subbase or subgrade removed without authorization by the Engineer shall be replaced and compacted by the Contractor at the Contractor's expense, with materials specified by the Engineer.

The Contractor shall restore all disturbed areas to better than or equal to their original condition. This includes the placement and compaction of 4 inches of topsoil, followed by placement of grass seed, followed by the placement fertilizer and mulch blanket at all turf restoration locations. All restoration work and materials shall be in accordance with the Detailed Specifications "Clean-up & Restoration, Special".

### **MEASUREMENT AND PAYMENT**

All saw-cutting to establish a neat line required for removals shall be included in the appropriate item of work, and will not be paid for separately.

Restoration work, including backfilling, compacting, topsoiling and seeding will not be paid for separately, but shall be included in the appropriate associated items of work.

HMA Surface Remove items shall be field measured and paid for at the Contract Unit Prices for their respective Contract (Pay) Items as follows:

**PAY ITEM**

**PAY UNIT**

HMA Surface Remove

Square Feet

The unit prices for this item of work shall include all labor, material, and equipment costs to perform all the work specified in the Standard Specifications and as modified by this Detailed Specification and disposal of the HMA material.

**DETAILED SPECIFICATION FOR  
ITEM #214 – SIDEWALK GRADING  
ITEM #215 – SIDEWALK RAMP GRADING**

**DESCRIPTION**

Remove miscellaneous structures and materials and complete all earthwork required to construct the proposed cross sections within the limits shown on the plans or stated in this special provision. All lines and grades will be as shown on the plans and as directed by the Engineer. Complete this work according to the MDOT 2012 Standard Specifications for Construction and this special provision.

**MATERIALS**

Furnish and place required subbase and embankment material conforming to the MDOT 2012 Standard Specifications for Construction as necessary to achieve the required typical cross sections. Excavated material, if suitable, may be used as embankment material as approved by the Engineer.

**CONSTRUCTION METHOD**

Complete this work according to applicable sections of the Standard Specifications for Construction. Sidewalk Grading includes, but is not limited to, the following work:

1. Strip and stockpile topsoil for use in turf establishment.
2. Furnish, place and compact additional material.
3. Clearing, including trees less than 8 inches in diameter.
4. Remove rocks or boulders less than 0.5 cubic yards in volume.
5. Remove and relocate mailbox posts and mailboxes.
6. Sawcut existing pavement.
7. Match drive and approach grades to new pavement grades.
8. Remove miscellaneous structures and materials.
9. Dispose of excess and unsuitable material according to Section 205.
10. Place embankment and reshape to proposed grades.
11. Excavate material to a depth necessary for construction.
12. Place embankment to a thickness necessary for construction.
13. Excavate for subbase material.

**MEASUREMENT AND PAYMENT**

The completed work, as described, will be measured and paid for at the contract unit price using the following pay item:

<b>Pay Item</b>	<b>Pay Unit</b>
Sidewalk Grading .....	Station
Sidewalk Ramp Grading .....	Each

**Sidewalk Grading** includes all labor, equipment and materials necessary to complete the work as described and will be measured by length in stations along the road centerline.

**Sidewalk Ramp Grading** will apply separately to each quadrant of an intersection where sidewalk is to be removed and/or graded for construction. The limits are specified on the plans or as directed by the Engineer.

**DETAILED SPECIFICATION  
FOR  
ITEM #216 – SEWER, ANY SIZE OR DEPTH, REMOVE  
ITEM #217 – DRAINAGE STRUCTURE, ANY SIZE OR DEPTH, REMOVE**

**DESCRIPTION**

This work shall include abandoning existing sewers and drainage structures of various size and depth as required by the Plans. All work shall be done in accordance with Section 203 of the 2012 Michigan Department of Transportation Standard Specifications for Construction, as directed by the Engineer, and as described herein.

**MATERIALS**

Granular Material Class II.....Section 902

**METHODS OF CONSTRUCTION**

Sewers, manholes, and drainage structures shall be removed and disposed of off-site, in such a manner as not to damage any new work, or work or material which is to remain in-place. The hole or trench resulting from the removal of the manhole, sewer, or drainage structure shall be backfilled with Granular Material, Cl II, in maximum lifts of 12 inches, and be compacted to 95% of its maximum unit weight, if located within the public rights-of-way, railroad rights-of-way, or within the influence paved surfaces or structures. Otherwise, backfill shall be Engineer approved native material, compacted to 90% of its maximum unit weight, in lifts of 12 inches or less, unless otherwise noted on the plans. The resulting hole left in a structure from a sewer to be removed shall be bulkheaded with bricks and mortar to provide a watertight seal and constructed such that the remaining flow in the manhole is not impeded.

As directed by the Engineer and within two days of their removal, the Contractor shall deliver the existing structure covers to the City of Ann Arbor Field Services Unit located at the W.R. Wheeler Service Center at 4251 Stone School Road, Ann Arbor, MI 48108.

**MEASUREMENT AND PAYMENT**

The completed work shall be paid for at the Contract Unit Price for the following Contract Items:

<b><u>PAY ITEM</u></b>	<b><u>PAY UNIT</u></b>
Sewer, Any Size or Depth, Remove	Foot
Drainage Structure, Any Size or Depth, Remove	Each

Payment for the above items shall include all labor, material, and equipment to complete the work.

**DETAILED SPECIFICATION  
FOR  
ITEM #218 – ADDITIONAL DEPTH STRUCTURE ADJUST/REPAIR**

**DESCRIPTION**

This work shall consist of removing and disposing of portions of existing brick or block masonry drainage structures, and rebuilding drainage structures of concrete block masonry in conformance with Section 403 of the Michigan Department of Transportation 2012 Standard Specifications for Construction except as specified herein. Water main gate wells and gate box covers shall be considered to be included in this item of work.

This shall also cover the repair of manholes and structures where less than the substantial rebuilding of the structure, as determined by the Engineer, is required.

**MATERIALS**

The materials shall meet the requirements as specified in Section 403.02 of the Michigan Department of Transportation 2012 Standard Specifications except as specified herein.

Concrete masonry units shall conform to the requirements for concrete masonry units for catch basins and manholes, ASTM C 139.

Concrete brick shall conform to the requirements for concrete building brick, ASTM C 55, Grade N-1

**CONSTRUCTION METHODS**

The Construction Methods shall meet the requirements of Section 403.03, except that the provisions of Section 403.03.D shall not apply to the work covered by this special provision.

The Contractor shall furnish and install pre-cast manhole tops (flat-tops) for the structures where needed. The flat-tops shall be included in this item of work and will be paid for separately.

**MEASUREMENT AND PAYMENT**

The completed work as measured for "Structure, Additional Depth Adjust/Repair" shall be paid for at the contract unit price for the following contract item (pay item):

<b><u>PAY ITEM</u></b>	<b><u>PAY UNIT</u></b>
Additional Depth Structure Adjust/Repair	Foot

"Additional Depth Structure Adjust/Repair" will be measured by depth in feet from a point 15 inches below finish grade of the structure down to the grade of the remaining structure, and will be paid for at the contract unit price per foot, which price shall be payment in full for all labor, equipment and materials needed to accomplish this work.



**DETAILED SPECIFICATION  
FOR  
ITEM #219 GUARDRAIL, REM**

**DESCRIPTION**

All work must be completed in accordance with section 204 of the Michigan Department of Transportation (MDOT) 2012 Standard Specifications for Construction, MDOT Standard Plans, City of Ann Arbor Special Details, and as specified herein, noted elsewhere on the plans, and as directed by the Engineer.

The work includes removal of the existing guardrail, beam elements, posts, anchorages, including concrete blocks and sleeves, wooden blocks, hardware and other items.

**MATERIALS**

Provide materials in accordance with the following section 204 of the 2012 MDOT Standard Specifications for Construction, City of Ann Arbor Special Details, and as specified herein, noted elsewhere on the plans, and as directed by the Engineer.

**CONSTRUCTION**

The construction shall conform to Section 204 of the 2012 MDOT Standard Specifications for Construction, the City of Ann Arbor Standard Specifications, and the plans.

**MEASUREMENT AND PAYMENT**

The completed work as described will be measured and paid for using the following pay item.

<b>PAY ITEM</b>	<b>PAY UNIT</b>
Guardrail, Rem	Foot

All work indicated herein shall be included in the unit prices for the above pay items and shall include all labor, materials and equipment required to complete the work. The Engineer will measure Guardrail, Rem along the face of the existing guardrail installation.

**DETAILED SPECIFICATION  
FOR  
ITEM #220 - REMOVE SANITARY SEWER LEAD**

**DESCRIPTION**

This work shall consist of removing and replacing existing sanitary lead pipe in new utility trenches as directed by engineer when conflicts with new utilities are identified or when the condition of the existing pipe prevents proper utility protection. Work includes cutting lead, carefully removing, replacing with SDR 35 PVC pipe and fittings along with Fernco connections. All materials need to accomplish this work is included in this pay item. All work shall be done in accordance with the City of Ann Arbor Public Services Department Standard Specifications, and as directed by the Engineer.

**CONSTRUCTION METHODS**

The Construction Methods shall meet all requirements of the City of Ann Arbor Standard Specifications.

Sewer leads are private and no official City records are kept. Approximate locations of leads have been placed on plans per survey data when available. Contractor to carefully excavate leads, not dig through lead but to saw cut out of way. Lead to be kept clean, have positive fall, and replaced as soon as possible. Contractor to coordinate with homeowner as needed to complete work. Trench must be carefully backfilled to prevent damage. Prior to placement of HMA contractor will have entire lead televised to verify condition of repaired sections and to verify sufficient slope has been provided. Any defects in the repaired sections shall be exposed and repaired at contractor's expense.

**MEASUREMENT AND PAYMENT**

The unit price for the pay item "Remove Sanitary Sewer Lead" includes all labor, material and equipment costs associated with the complete installation of the sewer lead, as specified herein, including but not limited to, excavation MDOT CL II backfill, compaction.

Payment shall include all labor, equipment, and materials necessary to remove and store the existing sewer lead as directed by the Engineer.

The unit prices for this item of work shall include all labor, material, and equipment costs to perform all the work specified in the Standard Specifications and as modified by this Detailed Specification.

**PAY ITEM**

Remove Sanitary Sewer Lead

**PAY UNIT**

Foot

**DETAILED SPECIFICATION  
FOR  
ITEM #221 – WATER MAIN PIPE ABANDONMENT, MODIFIED  
ITEM #222 – FIRE HYDRANT ASSEMBLY ABANDONMENT**

**DESCRIPTION**

This work shall include abandoning existing water mains, valves, valve wells, valve boxes, and fire hydrant assemblies of various sizes as required by the Plans. All work shall be done in accordance with the City of Ann Arbor Public Services Department Standard Specifications, and as directed by the Engineer.

**MATERIALS**

All materials shall meet the requirements specified in Division 7 and 9 of the MDOT 2003 Standard Specifications for Construction as follows:

Mortar Type II Section 702

MDOT Class II Sand Section 902

Masonry Units Section 913

Push-on joint plugs, caps, air relief assemblies (for grouting purposes), and thrust blocks shall conform to the City of Ann Arbor Standard Specifications.

**METHODS OF CONSTRUCTION**

The Construction Methods shall meet all requirements of the City of Ann Arbor Standard Specifications.

In locations as shown on the Plans or where abandoned water main, valves or valve wells are within 2.5 feet of the proposed subgrade, the pipe, valves or valve wells shall be removed completely. The resulting hole or trench shall be backfilled with Class II Sand, in maximum lifts of 12 inches, and be compacted to 95% of its maximum unit weight, if located within the influence paved surfaces or structures. Otherwise, backfill shall be Engineer approved native material, compacted to 90% of its maximum unit weight, in lifts of 12 inches or less, unless otherwise noted on the plans. Caps or plugs shall be installed in accordance with plans or as specified by Engineer.

Abandoned (salvaged) valve operating nuts, fire hydrant assemblies and structure covers shall be delivered to the City of Ann Arbor Field Services Unit located at the W.R. Wheeler Service Center at 4251 Stone School Road, Ann Arbor, MI 48108 within two days of their removal. Valve boxes should be disposed of at the contractor's sole expense.

**MEASUREMENT AND PAYMENT**

The unit price for the pay "Water Main Pipe Abandonment, Modified" shall be paid for on a lump sum (LS) basis and includes all labor, material and equipment costs necessary to abandon or remove the pipe including, but not limited to, excavation, cutting of pipe, push-on joint plugs, caps and thrust blocks, brick and mortar bulkheads, the furnishing, placement, and compaction of approved granular backfill material, as required, and the removal and proper disposal off-site of excess materials. In addition, this pay item includes the removal and salvage of valves, valve boxes, and manhole rings and covers, the removal of the

top 4 feet of valve wells, and breaking out the valve well base.

The unit price for the pay item "Fire Hydrant Assembly Abandonment," includes all labor, material and equipment costs associated with the complete removal of the existing fire hydrant assembly, as specified herein, including but not limited to, excavation MDOT CL II Backfill and compaction; pipe cutting; thrust block removal; pipe plug; thrust block; salvaging of fire hydrant, valve and valve box and delivery of fire hydrant, valve and valve box to the City of Ann Arbor Field Services Unit located at the W.R. Wheeler Service Center at 4251 Stone School Road, Ann Arbor, MI 48108.

**PAY ITEM**

**PAY UNIT**

Water Main Pipe Abandonment, Modified

Lump Sum

Fire Hydrant Assembly Abandonment

Each

The Item of work "Water Main Pipe Abandonment, Modified" will be paid for on a pro rata basis at the time of each progress payment. Measurement will be based on the ratio between work completed during the payment period and the total contract amount. When all of the work of this Contract has been completed, the measurement of this item shall be 1.0 Lump Sum, minus any deductions incurred for inadequate performance as described herein. This amount will not be increased for any reason, including extensions of time, extras, and/or additional work.

**DETAILED SPECIFICATION  
FOR  
ITEM #223 – TEMPORARY WATER MAIN LINE STOP, ADDITIONAL RENTAL DAY  
ITEM #224 - TEMPORARY WATER MAIN LINE STOP, LESS THAN 8 INCH  
ITEM #225 - TEMPORARY 8 INCH OR 12 INCH WATER MAIN LINE STOP**

**DESCRIPTION**

This work shall include all excavations, line stop contractor labor, materials, and backfill required to install a line stop on an existing water main. All work shall be done in accordance with the City of Ann Arbor Public Services Department Standard Specifications, and as directed by the Engineer.

**CONSTRUCTION METHODS**

Construction shall meet all requirements of the City of Ann Arbor Standard Specifications. All excavation shall be of sufficient size that work can be performed safely. Line stop work shall be coordinated with proposed water main shut down. The line stop Contractor must be on site at all times during the line stop operation.

**MEASUREMENT AND PAYMENT**

The unit prices for this item of work shall include all labor, material, and equipment costs to perform all the work specified in the Standard Specifications and as modified by this Detailed Specification. “Temporary Water Main Line stop, Additional Rental Day” will be paid for each day after the first installation and use day of a temporary water main line stop, regardless of size, until the line stop is no longer needed.

**PAY ITEM**

**PAY UNIT**

Temporary Water Main Line Stop, Additional Rental Day	Each
Temporary Water Main Line Stop, Less than 8 inch	Each
Temporary 8 inch or 12 inch Water Main Line Stop	Each

Backfill items associated with patching the excavation created by installing the line stop, such as Aggregate Base Course, 21AA- C.I.P. and Handpatching or HMA Pavement Leveling/Top - LVSP, will be paid for separately.

**DETAILED SPECIFICATION  
FOR  
ITEM #230 – MACHINE GRADING, MODIFIED**

**DESCRIPTION**

This work shall consist of constructing earth grades by excavating, cutting, filling, trimming, and grading; general restoration, and sign removals in accordance with the Detailed Specifications elsewhere herein; and maintaining the work in a finished condition until such time that it is accepted by the Engineer. This work shall be done as shown on the Plans, as detailed in the Specifications, and as directed by the Engineer, and in accordance with Section 205 of the 2012 edition of the MDOT Standard Specification for Construction, except as specified herein.

**CONSTRUCTION METHOD**

The Contractor shall construct earth grades as required to develop the typical and/or detailed cross-section(s) as shown on the Plans, as detailed in the Specifications, and as directed by the Engineer. This shall include, but not be limited to, the excavation of concrete and HMA pavement, soil, rocks of any size, stumps, trees less than 8 inches, logs, and bricks; the removal and proper disposal off-site of surplus excavated material; the scarifying, plowing, disking, moving and shaping of earth; the trimming, grading, compaction and proof-rolling of the prepared subgrade; the importing, furnishing, placement and compaction of embankment and/or fill materials; the full depth saw-cutting of pavement at the removal limits; the grading of sideslopes; general restoration in accordance with the Detailed Specifications elsewhere herein and the general items of the work as specified herein. Road subbase and base materials shall be paid for separately.

The Contractor shall remove, add to, re-shape, re-grade, and re-compact the existing roadbed materials, and shall construct the roadway to the cross-section(s) as indicated on the Plans, as detailed in the Specifications, and as directed by the Engineer. The Contractor shall use blade graders, maintainers, vibratory rollers, and/or other equipment as necessary, and as detailed in the Specifications and as directed by the Engineer, for this work. Use of each specific piece of equipment is subject to the approval of the Engineer.

The Contractor shall remove, salvage, deliver to any location within the City limits, and neatly stack/stockpile all bricks, if present, as directed by the Engineer.

The Contractor shall remove other surface features, including signs, located within the grading limits and not otherwise identified, as directed by the Engineer. Signs shall be salvaged and provided to City as directed by the Engineer.

The Contractor shall move excavated and/or imported materials longitudinally and/or transversely where necessary, and as directed by Engineer.

The Contractor shall keep the work well graded and drained at all times.

The Contractor shall not use rubber-tired equipment on the subgrade, when its use causes or may cause, in the opinion of the Engineer, damage to the subgrade. The Contractor shall conduct its operation(s), and provide all necessary equipment, to insure the satisfactory completion of the work without damaging the subgrade. This includes the transporting, stockpiling, rehandling, and movement of materials over

additional distances, in lieu of driving on an unprotected, or partially unprotected, subgrade.

The Contractor is solely responsible for the maintenance and protection of the subgrade. Further, any damage to the subgrade which, in the opinion of the Engineer, is caused as a result of the Contractor's operation(s), or its subcontractors' or suppliers' operation(s), shall be repaired by the Contractor at the Contractor's expense. This includes any additional earthwork and/or maintenance materials as directed by the Engineer, for the purposes of the Contractor's maintenance and protection of the subgrade. The Contractor shall not be entitled to any additional compensation for the implementation of these procedures.

The Contractor shall perform all rough and/or finish grading and compaction to the grades shown on the Plans, as detailed in the Specifications, and as directed by the Engineer.

The Contractor shall proofroll all graded and compacted surfaces in the presence of the Engineer as detailed in the Specifications. The Engineer will monitor the proofrolling operation to locate deleterious and/or uncompacted materials, and will direct undercuts as necessary.

At various times throughout the work, the Engineer may direct the Contractor to use smaller and/or lighter equipment, and to defer certain work tasks, in order to protect the grade and/or adjacent areas. The Contractor shall not be entitled to any additional compensation for the use of smaller equipment, lighter equipment, or work task deferral.

The Contractor shall take any and all steps necessary to avoid interruption in the mail delivery, and solid waste, recycling, and compostable pick-up within the project limits. This shall include the temporary relocation of mailboxes, where required by the Engineer, as well as moving of all solid waste/recycling/compost containers to the nearest cross street.

The Contractor shall coordinate with the Urban Forestry and Natural Resources Planning Coordinator prior to the removal of any tree roots 2 inches or larger in size.

Butt joints are included in the pay item "Machine Grading, Modified".

Topsoil, seeding, fertilizer, and mulch shall be paid for as items "Fertilizer, Chemical Nutrient, Cl A", "Mulch Blanket, High Velocity", "Seeding, Mixture THM", and "Topsoil Surface, Furn, 4 inch."

### **MEASUREMENT AND PAYMENT**

Measurement for payment for the item "Machine Grading" shall be the computed in square yard quantity of excavated material (pavement, soil, rock, brick, etc.) from the top of existing grade down to the bottom of the excavation. Embankment, fill, subgrade protection/maintenance, drainage maintenance quantities will not be paid for separately, and are included in this item of work.

The completed work as measured for this item of work will be paid for at the Contract Unit Price for the following Contract (Pay) Item:

#### **PAY ITEM**

Machine Grading, Modified

#### **PAY UNIT**

Square Yard

The unit price for this item of work shall include all labor, material, and equipment costs to perform all the work specified in the Standard Specifications and as modified by this Detailed Specification.

**DETAILED SPECIFICATION  
FOR  
ITEM #231 - SUBGRADE UNDERCUTTING - TYPE II**

**DESCRIPTION**

This work includes removal of unsuitable granular base, subbase or clay material(s) to depths as specified by the Engineer.

**CONSTRUCTION METHOD**

After the pavement has been removed, and/or after rough/finish grading, and/or at the time of proofrolling, the Engineer may inspect the grade to determine the need for, and the limits of, undercuts. After undercut areas are excavated to the depths as directed by the Engineer, the areas shall be trimmed, shaped, evenly graded and recompact to not less than 95% of the soils maximum unit weight as determined by the AASHTO T-180 test. The Contractor shall properly dispose of all excess materials.

Subgrade Undercutting - Type II shall be backfilled with 21AA, as directed by the Engineer. The backfill material shall be compacted to not less than 98% of its maximum unit weight as determined by the AASHTO T-180 test. The fill material(s) for Subgrade Undercutting Type II shall be paid at the Contract unit price for the corresponding items of work as used which is "21AA Limestone - C.I.P."

The Contractor shall remove, salvage, deliver to W.R. Wheeler Service Center (4251 Stone School Road, Ann Arbor, MI 48108), and neatly stack/stockpile all bricks, if present, as directed by the Engineer.

The Contractor shall remove, add to, re-shape, re-grade, and re-compact the existing roadbed materials, and shall construct the roadway to the cross-section(s) as indicated on the Plans, as detailed in the Specifications, and as directed by the Engineer. The Contractor shall use blade graders, maintainers, vibratory rollers, and/or other equipment as necessary, and as directed by the Engineer, for this work. Use of each specific piece of equipment is subject to the approval of the Engineer.

At various times throughout the work, the Engineer may direct the Contractor to use smaller and/or lighter equipment, and to defer certain work tasks, in order to protect the grade and/or adjacent areas. The Contractor shall not be entitled to any additional compensation for the use of smaller equipment, lighter equipment, or work task deferral.

**MEASUREMENT AND PAYMENT**

These items of work shall be measured for payment by calculating the volume of the undercut excavation prior to the placement of backfill.

The completed work as measured for these items of work will be paid for at the Contract Unit Prices for the following Contract (Pay) Items:

**PAY ITEM**

Subgrade Undercutting - Type II

**PAY UNIT**

Cubic Yard

The unit prices for these items of work shall include all labor, material, and equipment costs to perform all the work specified in the Standard Specifications and as modified by this Detailed Specification.



**DETAILED SPECIFICATION  
FOR  
ITEM #232 –SAND SUBBASE COURSE, CLASS II – C.I.P.  
ITEM #233 – 21AA LIMESTONE – C.I.P.  
ITEM #234 – AGGREGATE BASE COURSE, 21AA – C.I.P.**

**DESCRIPTION**

This work shall consist of constructing an aggregate subbase or base course on an existing aggregate surface, or on a prepared subgrade in accordance with Sections 301, 302 and 307 of the 2012 edition of the MDOT Standard Specifications for Construction, except as specified herein.

**MATERIAL**

The materials used for this work shall be MDOT 21AA, and Class II granular material, as modified meeting the requirements of the City of Ann Arbor Standard Specifications.

**CONSTRUCTION METHOD**

Sand or aggregate courses shall not be placed if, in the opinion of the Engineer, there are any indications that they may become frozen before their specified densities are obtained.

Sand or aggregate courses shall not be placed on a frozen base, subbase or subgrade.

The Contractor shall not use rubber-tired equipment on the grade, when its use causes, or may cause, in the opinion of the Engineer, damage to the grade. The Contractor shall conduct his/her operation(s), and provide all necessary equipment, to insure the satisfactory completion of the work without damaging the grade. This includes the transporting, stockpiling, rehandling, and movement of materials over additional distances, in lieu of driving on an unprotected, or partially unprotected, grade.

The Contractor is solely responsible for the maintenance and protection of the grade. Further, any damage to the grade which, in the opinion of the Engineer, is caused as a result of the Contractor's operation(s), or his/her subcontractors' or suppliers' operation(s), shall be repaired by the Contractor at the Contractor's expense. This includes any additional earthwork and/or maintenance materials as directed by the Engineer, for the purposes of the Contractor's maintenance and protection of the grade.

The Contractor shall shape the base, subbase and subgrade to the elevations, crowns, and grades as specified on the Plans and as directed by the Engineer. This may include regrading the subbase to provide different crown grades than those existing prior to the construction.

The Contractor shall remove, add to, re-shape, re-grade, and re-compact the existing roadbed materials, and shall construct the roadway to the cross-section(s) as indicated on the Plans, as detailed in the Specifications, and as directed by the Engineer. The Contractor shall use blade graders, maintainers, vibratory rollers, and/or other equipment as necessary, and as directed by the Engineer, for this work. Use of each specific piece of equipment is subject to the approval of the Engineer.

The Contractor shall maintain the base, subbase and subgrade in a smooth, well drained condition at all times.

Sand and aggregate courses shall be placed in uniform layers such that when compacted, they have the thicknesses shown on the Plans, or as directed by the Engineer. The loose measure of any layer shall not be more than 9-inches or less than 4-inches.

Sand subbase shall be compacted to not less than 95% of their respective maximum unit weights, as determined by the AASHTO T-180 test.

Aggregate base courses shall be compacted to not less than 98% of their respective maximum unit weights, as determined by the AASHTO T-180 test.

All granular materials shall be deposited from trucks or through a spreader in a manner that will minimize segregation of material.

Manholes, valve boxes, inlet structures and curbs shall be protected from damage. Manholes & inlet structures shall be continuously cleaned of construction debris and properly covered at all times during the construction. Upon completion of each day's work, manholes, water valve boxes, inlets and catch basins shall be thoroughly cleaned of all extraneous material.

At various times throughout the work, the Engineer may direct the Contractor to use smaller and/or lighter equipment, and to defer certain work tasks, in order to protect the grade and/or adjacent areas. The Contractor shall not be entitled to any additional compensation for the use of smaller equipment, lighter equipment, or work task deferral.

### **MEASUREMENT AND PAYMENT**

Where granular materials are used as base, as subbase, or as fill for excavations in Machine Grading areas, items of work "Aggregate Base Course, 21AA -C.I.P." and "Sand Subbase Course, CL II - C.I.P." shall be measured and paid accordingly.

Where granular materials are used as fill for undercuts at locations other than Machine Grading areas, item of work "21AA Limestone - C.I.P." shall be measured and paid accordingly.

The completed work as measured for these items of work will be paid for at the Contract Unit Prices for the following Contract (Pay) Items:

<b><u>PAY ITEM</u></b>	<b><u>PAY UNIT</u></b>
Sand Subbase Course, Class II - C.I.P.	Cubic Yard
21AA Limestone - C.I.P.	Cubic Yard
Aggregate Base Course, 21AA - C.I.P.	Ton

The unit prices for these items of work shall include all labor, material, and equipment costs to perform all the work specified in the Standard Specifications and as modified by this Detailed Specification.

**DETAILED SPECIFICATION  
FOR  
ITEM #237 HMA PAVEMENT LEVELING/TOP - LVSP  
ITEM #238 HMA APPROACH  
ITEM #239 HANDPATCHING**

**DESCRIPTION**

This work shall consist of constructing HMA pavement leveling and top courses in accordance with Division 5 and Section 904 of the 2012 edition of the MDOT Standard Specifications, current supplemental MDOT specifications, and the City of Ann Arbor Standard Specifications, except as modified herein, and as directed by the Engineer.

**MATERIALS AND EQUIPMENT**

General

The HMA mixtures to be used for this work shall be as follows:

<u>WORK ITEM</u>	<u>MDOT HMA MIXTURE #</u>
HMA Pavement Leveling/Top	LVSP (Superpave)
HMA Approach	LVSP (Superpave)
Handpatching	LVSP (Superpave)

Binders for LVSP Superpave mixes shall be PG 58-28, or as directed by Engineer. These shall meet the requirements specified in Section 904 of the 2012 edition of the MDOT Standard Specifications, and any current supplemental MDOT specifications.

The Aggregate Wear Index (AWI) number for this project is 260 for LVSP. This AWI number applies to all aggregates used in all top course mixtures. Blending aggregates to achieve this AWI requirement is permitted in accordance with current MDOT Standards, and Supplemental Specifications.

Reclaimed Asphalt Pavement (RAP) in HMA Mixtures

The use of Reclaimed Asphalt Pavement (RAP) in HMA mixtures shall be in accordance with Section 501.02.A.2 of the 2012 edition of the MDOT Standard Specifications, and the City of Ann Arbor Standard Specifications.

**CONSTRUCTION METHODS**

All concrete work shall be completed prior to placing HMA mixtures.

The Contractor shall have a 10-foot long straight-edge, backhoe, air-compressor and jackhammer available during all paving operations.

Prior to placing the bond coat, the Contractor shall remove all vegetation (within the area to be paved), shall thoroughly clean all joints & cracks in the existing pavement (and any gutter to be overlaid) with compressed air and/or vacuum-type street cleaning equipment to remove all dirt and debris to a depth of at least 1-inch, and shall thoroughly clean the entire surface to be paved, with a Vac-All or similar vacuum-type street cleaning equipment.

MDOT SS-1h bond coat shall be applied at a uniform rate of 0.10 gallons/square yard, on all exposed, existing HMA and concrete surfaces which will come in contact with the new HMA material. The Contractor shall take extra care to avoid covering surfaces which are not to be paved. If work after October 15, 2020 is allowed by the Engineer, the SS-1h bond coat shall not be diluted by more than 25%.

The Contractor shall place HMA wedges using the leveling or base mixture specified herein, as directed by the

Engineer, prior to placing the top course. Such wedging shall be measured and paid for at the respective unit price of the appropriate HMA Pavement item.

Construction of butt joints, where directed by the Engineer, shall be measured and paid for as "HMA Surface Remove".

The Contractor shall schedule the paving operation to avoid longitudinal cold joints.

HMA Pavement Leveling/Top - LVSP top and leveling courses shall be placed in a 2-inch lifts.

HMA Approach top and leveling courses shall be placed in a 2-inch lifts.

Handpatching shall be placed in 0-inch to 4-inch lifts.

All specified HMA thickness dimensions are compacted-in-place.

The Contractor shall construct the pavement courses to provide the final cross-slopes (crowns) specified by the Engineer.

The Contractor shall construct feather joints, and shall feather the top course at structures, in drive approaches, and at intersection joints, as directed by the Engineer. Feather joints shall vary the thickness of the asphalt from 0.0-inches to the required full paving thickness (approximately 2 inches) over a 5-foot to 15-foot distance, or as directed by the Engineer. The Contractor shall rake all large aggregates out of the HMA mixture in feather joints, prior to compaction.

The Contractor shall provide a minimum of two rakers during the placement of all top courses. Further, the Contractor shall provide, when directed by the Engineer, a second "Break-Down" roller in order to achieve the specified asphalt densities.

The Contractor shall provide a minimum of 24-hour notice to the Engineer prior to paving, and shall obtain a "Permit To Pave" from the Engineer in advance of scheduling paving.

The Contractor and Engineer shall carefully observe the paving operation for signs of faulty mixtures. Points of weakness in the surface shall be removed or corrected by the Contractor, at his/her expense, prior to paving subsequent lifts of HMA material. Such corrective action may include the removal and replacement of thin or contaminated sections of pavement, including sections that are weak or unstable. Once the Contractor or his representative is notified by the Engineer that the material being placed is out of allowable tolerances, or there is a problem with the paving operation, the Contractor shall stop the paving operation at once, and shall not be permitted to continue placing HMA material until again authorized by the Engineer.

During the placement of all courses, the speed of the paving machine(s) shall not exceed 50-feet per minute.

The Contractor shall furnish and operate enough materials and equipment so as to keep the paving machine(s) moving continuously at all times. Failure to do so shall be cause for the suspension of the paving operation until the Contractor can demonstrate to the satisfaction of the Engineer, that sufficient resources have been dedicated to perform the work in accordance with the specifications.

Each layer of HMA mixture shall be compacted to between 92 to 96 percent (or as determined acceptable by the engineer) of the theoretical maximum density, as listed on the approved Job Mix Formula.

At various times throughout the work, the Engineer may direct the Contractor to use smaller and/or lighter equipment, and to defer certain work tasks, in order to protect the grade and/or adjacent areas. The Contractor shall not be entitled to any additional compensation for the use of smaller equipment, lighter equipment, or work task deferral.

**MEASUREMENT AND PAYMENT**

Measurement of this HMA paving item shall be by the ton, in place. Unused portions of material loads shall be returned to the plant and re-weighed, and the corrected weight slip shall be provided to the Engineer. All weight slips must include the type of mixture (codes are not acceptable), as well as vehicle number, gross weight, tare weight and net weight.

Corrective action shall be enforced as described in the “Acceptance of HMA Mixtures” Detailed Specification and will be based on the City's testing reports.

All costs for furnishing and operating vacuum-type street cleaning equipment, backhoes, jackhammers, and air compressors shall be included in the bid prices for these items of work or in the item of work “General Conditions, Max \$30,000.”

The completed work as measured for these items of work will be paid for at the Contract Unit Prices for the following Contract (Pay) Items:

<b><u>PAY ITEM</u></b>	<b><u>PAY UNIT</u></b>
HMA Pavement Leveling/Top – LVSP	Ton
HMA Approach	Ton
Handpatching	Ton

The unit price for this item of work shall include all labor, material, and equipment costs to perform all the work specified in the Standard Specifications and as modified by this Detailed Specification.

**DETAILED SPECIFICATION  
FOR  
ITEM #240 CONCRETE CURB OR CURB AND GUTTER - ALL TYPES  
ITEM #241 CONCRETE CURB OR CURB AND GUTTER - ALL TYPES (HIGH EARLY)  
ITEM #242 4 INCH CONCRETE SIDEWALK  
ITEM #243 6 INCH CONCRETE SIDEWALK OR SIDEWALK RAMP  
ITEM #244 6 INCH CONCRETE DRIVE - HIGH-EARLY**

**DESCRIPTION**

This work shall consist of constructing concrete items including curb, gutter, curb and gutter, sidewalks, drive approaches, City of Ann Arbor Type M drive openings, all of any type and/or dimensions, all of either regular, fibermesh reinforced, and/or high-early concrete, in accordance with Sections 601, 602, 603, 801, 802, and 803 of the 2012 edition of the MDOT Standard Specifications for Construction, except as specified herein, as shown on the Plans, as shown in this Detailed Specification, and as directed by the Engineer.

**The Contractor is responsible to construct all sidewalks, sidewalk ramps, curbs, and all other concrete items within ADAAG compliance.** All sidewalks and curb ramps must be constructed in accordance with MDOT Standard Detail R-28 Series (version in place at time of the bid letting).

**MATERIALS**

Concrete mixtures shall be as follows (or as directed by the Engineer), and concrete materials shall meet the requirements specified in the referenced sections of the MDOT Standard Specifications:

<u>Concrete Item</u>	<u>Concrete Mixture</u>	<u>MDOT Section</u>
Curb or Curb & Gutter	P1, 6-sack	601
Curb or Curb & Gutter, High-Early	HE, 8.4-sack	601
4" or 6" Sidewalk or Ramp	P1, 6-sack	601
6" Drive - High-Early	HE, 8.4-sack	601

**CONSTRUCTION METHODS**

General

Concrete items, including sidewalk, non-integral curb/gutter, drives, and structure adjustments shall be completed prior to the placement of pavement.

All subgrade work shall be completed prior to placing concrete items, unless directed or approved by the Engineer.

The subbase shall be trimmed to final elevation before placing curb. Curb shall not be placed on a pedestal or mound.

The Contractor shall excavate, cut, remove stumps, remove brush, remove pavement, grade, and trim as needed and as directed, and shall import, furnish, fill, place, grade, and compact Class II granular material and 21AA Aggregate material as needed to: construct new concrete items; to repair or replace existing concrete items; to relocate existing concrete items to their new specified/directed elevations/locations, including all necessary grading at elevation changes of curb and gutter, sidewalks and ramps; and at locations where existing concrete items are to be removed and turf is to be established in its place.

At locations where the constructed subbase becomes either disturbed, saturated or otherwise damaged, and where directed by the Engineer, the Contractor shall remove a minimum 6-inch thick layer of the subbase and replace it with "Sand Subbase Course, CL II - C.I.P.". If additional subgrade requires removal as directed by the Engineer refer to specification for "Subgrade Undercutting – Type II".

**The Contractor shall coordinate with the Urban Forestry and Natural Resources Planning Coordinator prior to the removal of any tree roots with diameters 2" or greater.**

The Contractor is responsible for any damage to concrete items, including but not limited to vandalism; vehicular,

pedestrian and/or miscellaneous structural damage; surface texture damage; and rain damage.

The Contractor shall maintain on-site at all times, a sufficient quantity of adequate materials to protect concrete items. The Engineer may suspend or defer concrete placement if rain protection is not available. The Contractor shall not be entitled to any additional compensation due to work suspension or deferral resulting from a lack of adequate rain protection.

The Contractor shall perform full-depth saw cutting at removal limits, including those necessary to construct 2-foot wide Type M drive openings, and including those necessary to provide for the partial removal of existing drive approaches, as shown on the Plans, as directed by the Engineer, and as marked for removal.

The subbase and adjacent concrete shall be sufficiently wet-down with water prior to placing concrete, to prevent water loss from the new concrete, and to form a better bond between old and new concrete. If a cold-joint becomes necessary, (the) existing concrete surface(s) shall be cleaned with compressed air to expose the aggregate in the concrete.

Where it is necessary to remove existing pavement to provide space for concrete formwork, a sufficient amount of the existing pavement shall be removed to allow for the use of a vibratory plate compactor in front of the curb.

Where concrete items are placed in areas adjacent to existing pavement that is beyond the general resurfacing (pavement removal and/or milling) limits, the adjacent pavement area shall be backfilled and permanently patched within 48-hours of the removal of concrete formwork. The backfill material shall be MDOT 21AA aggregate compacted in place to 95% of its maximum unit weight, up to the elevation of the proposed bottom of pavement. The pavement patching material(s) shall be as specified and as directed by the Engineer.

Where concrete items are placed adjacent to existing pavement that is within areas scheduled for subsequent pavement removal and/or milling, the adjacent pavement area shall, within 48-hours of the removal of concrete formwork, be backfilled with MDOT 21AA aggregate, as modified, compacted in place to 98% of its maximum unit weight, up to the elevation of the bottom of the adjacent pavement.

Prior to compacting backfill in front of curb and gutter, the back of curb shall be backfilled with approved material and compacted by mechanical means to 95% of the material's maximum unit weight.

At various times throughout the work, the Engineer may direct the Contractor to use smaller and/or lighter equipment, and to defer certain work tasks, in order to protect the grade and/or adjacent areas. The Contractor shall not be entitled to any additional compensation for the use of smaller equipment, lighter equipment, or work task deferral.

#### Contraction Joints in Sidewalk

Contraction joints shall be placed at 5-foot intervals and may be tooled or sawed. The method of forming joints and spacing shall be approved by the Engineer prior to construction.

#### Expansion Joints in Sidewalks

¾-inch wide expansion joints shall be placed through concrete sidewalks in line with the extension of all property lines, at all expansion joints in the abutting curb, gutter, and combination curb and gutter, and as directed by the Engineer. Transverse expansion joints shall be placed through the sidewalks at uniform intervals of not more than 300-feet.

½-inch wide expansion joints shall be placed between the sidewalk and back of abutting curb or gutter, at the juncture of two sidewalks, between the sidewalk and buildings and other rigid structures, and as directed by the Engineer.

#### Expansion Joints in Curb and Gutter

¾-inch wide expansion joints shall be placed at all street returns, at all expansion joints in an abutting pavement, at each side of all driveways (at radius points), elsewhere at 300-foot maximum intervals, and as directed by the Engineer.

Expansion joint material shall extend to the full depth of the joint. After installation, the top shall not be above the

concrete nor be more than ½-inch below it. No reinforcing steel shall extend through expansion joints.

**Plane of Weakness Joints in Curb and Gutter**

Intermediate plane of weakness joints shall be placed to divide the structure into uniform sections, normally 10-feet in length, with a minimum being 8-feet in length, and shall be placed opposite all plane of weakness joints in the abutting concrete base course.

Plane of weakness joints shall be formed by narrow divider plates, which shall extend 3-inches into the exposed surfaces of the curb or curb and gutter. Plates shall be notched, if necessary, to permit the steel reinforcement to be continuous through the joint.

**MEASUREMENT AND PAYMENT**

No additional compensation will be paid for the construction of concrete items adjacent to existing concrete curb, gutter, pavement, or any other pavement or surface feature(s) which requires modified construction to smoothly blend the proposed to existing.

The removal of existing subgrade, or the installation of subbase or base necessary to construct item per City of Ann Arbor standards will be paid as “Machine Grading, Modified”, “Sand Subbase Course, Class II – C.I.P”, and “Aggregate Base Course, 21AA – C.I.P”. Removal of a greater depth, as directed by the Engineer, shall be paid for as “Subgrade Undercutting – Type II”. Replacement with approved "21AA Limestone, C.I.P.” will be paid for separately. Removal of existing earth where new sidewalk is installed will be paid for as “Sidewalk Grading” or “Sidewalk Ramp Grading.”

A deduction in length for catch basins and inlet castings will be made to measurements of Curb and Gutter.

Curb, gutter, curb and gutter, and City of Ann Arbor type M openings, shall be paid as "Concrete Curb and Gutter – All Type".

Payment for saw cutting for Type M openings and for partial removal of existing drives shall be included in the price for the item of work, “Remove Concrete Sidewalk and Drives - Any Thickness”, and will not be paid for separately.

Payment for the removal of HMA pavement and aggregate base to provide space for concrete formwork and vibratory plate compactor shall be included in the price for the item of work, “Remove Concrete Curb or Curb and Gutter - Any Type”, and will not be paid for separately.

The Item, “Detectable Warning, Cast In Place” will be measured and paid for by the square foot of area stamped, typically 2' x 5'. This measurement/payment is in addition to the measurement/payment for the concrete ramp placement.

Completed work as measured for these items of work will be paid for at Contract Unit Price for the following Contract (Pay) Items:

<b><u>PAY ITEMS</u></b>	<b><u>PAY UNIT</u></b>
Concrete Curb or Curb and Gutter – All Types	Feet
Concrete Curb or Curb and Gutter – All Types (High Early)	Feet
4 Inch Concrete Sidewalk	Square Feet
6 Inch Concrete Sidewalk or Sidewalk Ramp	Square Feet
6 Inch Concrete Drive - High Early	Square Feet

The unit prices for these items of work shall include all labor, material, and equipment costs to perform all the work specified in the Standard Specifications and as modified by this Detailed Specification.



**DETAILED SPECIFICATION  
FOR  
ITEM #245 -DETECTABLE WARNING, CAST IN PLACE**

**DESCRIPTION**

This work shall consist of furnishing and installing cast in place detectable warning units in compliance to the Americans with Disability Act (ADA). All work shall be in accordance with MDOT Standard Detail R-28 Series (version in place at time of the bid letting).

**MATERIALS AND CONSTRUCTION METHODS**

The detectable warning tiles shall be ceramic cement or composite polymer concrete (CRC), colored as Federal Number 22144 (frequently referred to as "Colonial Red" or "Brick Red"). The detectable warning tiles shall meet the following dimensions and tolerances:

1. Dimensions: Cast In Place Detectable/tactile Warning Surface Tiles shall be held within the following dimensions and tolerances:
  - Length: 24"
  - Width: The full width of the approaching walk (60" for typical sidewalk)
  - Depth: 1.375" (1-3/8") (+/-) 5% max.
  - Face Thickness: 0.1875" (3/16") (+/-) 5% max. Warpage of Edge: 0.5% max.
  - Embedment Flange Spacing: shall be no greater than 3.1"
2. Water Absorption of Tile when tested by ASTM D 570-98 not to exceed 0.05%.
3. Slip Resistance of Tile when tested by ASTM C 1028-96 the combined Wet and Dry Static Co-Efficient of Friction not to be less than 0.80 on top of domes and field area.
4. Compressive Strength of Tile when tested by ASTM D 695-02a not to be less than 28,000 psi.
5. Tensile Strength of Tile when tested by ASTM D 638-03 not to be less than 19,000 psi.
6. Flexural Strength of Tile when tested by ASTM D 790-03 not to be less than 25,000 psi.
7. Chemical Stain Resistance of Tile when tested by ASTM D 543-95 (re approved 2001) to withstand without discoloration or staining - 10% hydrochloric acid, urine, saturated calcium chloride, black stamp pad ink, chewing gum, red aerosol paint, 10% ammonium hydroxide, 1% soap solution, turpentine, Urea 5%, diesel fuel and motor oil.
8. Abrasive Wear of Tile when tested by BYK - Gardner Tester ASTM D 2486-00 with reciprocating linear motion of  $37 \pm$  cycles per minute over a 10" travel. The abrasive medium, a 40 grit Norton Metallite sand paper, to be fixed and leveled to a holder. The combined mass of the sled, weight and wood block is to be 3.2 lb. Average wear depth shall not exceed 0.060 after 1000 abrasion cycles when measured on the top surface of the dome representing the average of three measurement locations per sample.
9. Resistance to Wear of Unglazed Ceramic Tile by Taber Abrasion per ASTM C501-84 (re approved 2002) shall not be less than 500.
10. Fire Resistance of Tile when tested to ASTM E 84-05 flame spread shall be less than 15.
11. Gardner Impact to Geometry "GE" of the standard when tested by ASTM D 5420-04 to have a mean failure energy expressed as a function of specimen thickness of not less than 550 in. Ibf/in. A failure is noted when a crack is visible on either surface or when any brittle splitting is observed on the

bottom plaque in the specimen.

12. Accelerated Weathering of Tile when tested by ASTM G 155-05a for 3000 hours shall exhibit the following result -  $\square E < 4.5$ , as well as no deterioration, fading or chalking of surface.
13. Accelerated Aging and Freeze Thaw Test of Tile and Adhesive System when tested to ASTM D 1037-99 shall show no evidence of cracking, delamination, warpage, checking, blistering, color change, loosening of tiles or other detrimental defects.
14. Salt and Spray Performance of Tile when tested to ASTM B 117-03 not to show any deterioration or other defects after 200 hours of exposure.
15. AASHTO HB-17 single wheel HS20-44 loading "Standard Specifications for Highways and Bridges". The Cast In Place Tile shall be mounted on a concrete platform with a 1/2" airspace at the underside of the tile top plate then subjected to the specified maximum load of 10,400 lbs., corresponding to an 8000 lb individual wheel load and a 30% impact factor. The tile shall exhibit no visible damage at the maximum load of 10,400 lbs.
16. Embedment flange spacing shall be no greater than 3.1" center to center spacing as illustrated on the product Cast In Place drawing.

### **CONSTRUCTION METHODS**

The contractor shall follow manufacturer specifications for installation, except where they conflict with MDOT Standard Detail R-28 Series (version in place at time of the bid letting).

### **MEASUREMENT AND PAYMENT**

The completed work as measured for this item of work will be paid for at the Contract Unit Prices for the following Contract (Pay) Item:

<b><u>PAY ITEM</u></b>	<b><u>PAY UNIT</u></b>
Detectable Warning, Cast In Place	Square Feet

The unit price for this item of work shall include all labor, material, and equipment costs to perform all the work specified in the Standard Specifications and as modified by this Detailed Specification.

**DETAILED SPECIFICATION  
FOR  
ITEM #246 – INTEGRAL SIDEWALK RETAINING WALL, UNDER 6 INCH  
ITEM #247 – INTEGRAL SIDEWALK RETAINING WALL, 6 INCH TO 18 INCH  
ITEM #248 – INTEGRAL SIDEWALK RETAINING WALL, 19 INCH TO 36 INCH**

**DESCRIPTION**

This work shall consist of constructing concrete retaining walls adjacent to sidewalks, in accordance with Section 802 of the 2012 edition of the MDOT Standard Specifications for Construction, except as specified herein, as described in this Detailed Specification, as shown in the typical section, and as directed by the Engineer.

**MATERIAL**

Concrete mixtures shall be Grade P1 or S2 concrete, or as directed by the Engineer, meeting the requirements specified in Section 803 of the MDOT Standard Specifications. Epoxy Coated Reinforcement Steel meeting the requirements specified in Section 905 of the MDOT Standard Specifications, Course Aggregate 6A and Open Graded Aggregate 2NS Sand meeting the requirements specified in Section 902 of the MDOT Standard Specifications, Geotextile Liner meeting the requirements specified in Section 910 of the MDOT Standard Specifications, and Conduit meeting the requirements specified in Section 918 of the MDOT Standard Specifications shall be included in “Integral Sidewalk Retaining Wall, 6 inch to 18 inch” and “Integral Sidewalk Retaining Wall, 19 inch to 36 inch” and not paid for separately.

**CONSTRUCTION METHOD**

The Contractor shall construct the Integral Sidewalk Retaining Walls as shown in accordance with the detail contained in the Contract Documents. Construction shall be in accordance with Section 802 of the 2012 MDOT Standard Specifications for Construction. The construction of the Keyway Construction Joint shall be included in “Integral Sidewalk Retaining Wall, 6 inch to 18 inch” and “Integral Sidewalk Retaining Wall, 19 inch to 36 inch” and not paid for separately.

**MEASUREMENT AND PAYMENT**

Payment shall be measured by the exposed face area of the retaining wall in square feet. The completed work, as described, will be measured and paid for at the contract unit price for the following pay item:

<b><u>PAY ITEM</u></b>	<b><u>PAY UNIT</u></b>
Integral Sidewalk Retaining Wall, under 6 inch	Square Feet
Integral Sidewalk Retaining Wall, 6 inch to 18 inch	Square Feet
Integral Sidewalk Retaining Wall, 19 inch to 36 inch	Square Feet

Payment for Integral Sidewalk and Retaining Wall for the respective height shall include all labor, equipment and materials to complete this work.

**DETAILED SPECIFICATION  
FOR  
ITEM #250 PAVT MRKG, OVLY COLD PLASTIC, 12 INCH, CROSSWALK  
ITEM #251 PAVT MRKG, OVLY COLD PLASTIC, 24 INCH, STOP BAR  
ITEM #252 PAVT MRKG, OVLY COLD PLASTIC, DIRECTION ARROW SYM, BIKE  
ITEM #253 PAVT MRKG, OVLY COLD PLASTIC, BIKE, SMALL SYM  
ITEM #254 PAVT MRKG, OVLY COLD PLASTIC, SHARROW SYMBOL  
ITEM #255 PAVT MRKG, POLYUREA, 4 INCH, WHITE  
ITEM #256 PAVT MRKG, POLYUREA, 4 INCH, YELLOW  
ITEM #257 PAVT MRKG, POLYUREA, 6 INCH, WHITE  
ITEM #258 RECESSING PAVT MRKG, LONGIT**

**DESCRIPTION**

This work consists of providing and placing permanent pavement markings in accordance with the Michigan Manual of Uniform Traffic Control Devices (MMTUTCD), lasted version published at time of advertisement. Provide pavement markings that conform to the Plans, the Michigan Department of Transportation (MDOT) 2012 Standard Specifications for Construction, MDOT Pavement Marking Standard Plans, City of Ann Arbor Special Details, and as specified herein.

**MATERIALS**

Provide materials in accordance with section 811 and 920 of the MDOT 2012 Standard Specifications for Construction. Provide the Material Safety Data Sheets to the Engineer for required materials and supplies. Dispose of unused material and containers in accordance with the Federal Resource Conservation Recovery Act (RCRA) of 1976 as amended, and 1994 PA 451, Part 111 Hazardous Waste Management. Provide samples of permanent marking materials upon request.

**CONSTRUCTION METHODS**

The preparation and placement of permanent markings shall conform to section 811 of the MDOT 2012 Standard Specifications, the Plans, and as specified herein.

**MEASUREMENT AND PAYMENT**

Completed work, as described, will be measured and paid for at Contract Unit Prices for the following Contract (Pay) Items:

<b><u>PAY ITEMS</u></b>	<b><u>PAY UNIT</u></b>
Pavt Mrkg, Ovly Cold Plastic, 12 inch, Crosswalk	Foot
Pavt Mrkg, Ovly Cold Plastic, 24 inch, Stop Bar	Foot
Pavt Mrkg, Ovly Cold Plastic, Direction Arrow Sym, Bike	Each
Pavt Mrkg, Ovly Cold Plastic, Bike, Small Sym	Each
Pavt Mrkg, Ovly Cold Plastic, Sharrow Symbol	Each
Pavt Mrkg, Polyurea, 4 inch, White	Foot
Pavt Mrkg, Polyurea, 4 inch, Yellow	Foot
Pavt Mrkg, Polyurea, 6 inch, White	Foot
Recessing Pavt Mrkg, Longit	Foot

The unit prices for these items of work shall include all labor, material, and equipment costs to perform all the work specified in the MDOT 2012 Standard Specifications for Construction and as modified by this Detailed Specification.

**DETAILED SPECIFICATION  
FOR  
ITEM #264 PAVT MRKG COVER, TYPE R, BLACK  
ITEM #265 PAVT MRKG, WET REFLECTIVE, TYPE R, TAPE, 4 INCH, WHITE, TEMP  
ITEM #266 PAVT MRKG, WET REFLECTIVE, TYPE R, TAPE, 4 INCH, YELLOW, TEMP  
ITEM #267 PAVT MRKG, WET REFLECTIVE, TYPE R, TAPE, 6 INCH CROSSWALK  
ITEM #268 PAVT MRKG, WET REFLECTIVE, TYPE R, TAPE, 24 INCH STOP BAR  
ITEM #269 – TEMPORARY CURB FOR BUMP-OUT  
ITEM #270 – SIGN, PORTABLE CHANGEABLE MESSAGE, FURNISH AND OPERATE  
ITEM #271 – PLASTIC DRUM – LIGHTED, FURNISH & OPERATE  
ITEM #272 – BARRICADE TYPE III – LIGHTED, FURNISH AND OPERATE  
ITEM #273 – TEMPORARY SIGN - TYPE B, FURNISH AND OPERATE  
ITEM #274 – CHANNELIZING DEVICE, 42 INCH, FURNISH AND OPERATE  
ITEM #275 – PEDESTRIAN TYPE II BARRICADE, TEMP  
ITEM #276 – SIGN COVER**

**DESCRIPTION**

This work shall consist of protecting and maintaining vehicular and pedestrian traffic, in accordance with Sections 812 and 922 of the 2012 MDOT Standard Specifications for Construction; Part 6 of the Michigan Manual of Uniform Traffic Control Devices, Latest Revised Edition (MMUTCD); and the City Standard Specifications, except as modified herein.

**MATERIALS, EQUIPMENT, AND CONSTRUCTION METHODS**

**General**

Materials and equipment shall meet the requirements specified in the above-designated sections of the MDOT Standard Specifications.

The Contractor shall maintain traffic such that no vehicle shall be required to drive into active work areas. Patch areas which extend more than halfway across the roadway shall always be removed and replaced to provide a minimum of half the pavement width for maintaining traffic.

The Contractor shall maintain pedestrian traffic at all times. For maintaining normal pedestrian traffic while performing sidewalk and driveway repair, **Pedestrian Type II Barricade, Temp** shall be placed by the Contractor, as directed by the Engineer. "Sidewalk Closed" and/or "Cross Here" signs shall be placed, by the Contractor, when directed by the Engineer.

All temporary traffic/pedestrian control devices furnished by the Contractor shall remain the property of the Contractor, EXCEPT Temporary Curb for Bump-out. The City shall not be responsible for stolen or damaged signs, barricades, barricade lights or other traffic maintenance items. The Contractor shall replace missing traffic control devices immediately, at no additional cost to the City.

All existing signs, and signs erected by the City of Ann Arbor on this project shall be preserved, protected, and maintained by the Contractor. Existing City owned signs which are damaged by the Contractor during the work will be repaired by the City at the Contractor's expense.

Parking violation citations issued to the Contractor, subcontractor and material suppliers, including their employees, shall be enforced under appropriate City Code.

The Contractor shall replace missing or damaged traffic control devices, as directed by the Engineer. When traffic control devices have been damaged by, or due to, the negligence of the Contractor, his subcontractors

or material suppliers, the traffic control devices shall be replaced at the Contractor's expense.

### **Temporary Curb for Bump-out**

The Contractor shall supply QWIK KURB curb, or equivalent. The curb color shall be white and have posts, bollards, or panels with white reflective face. Manufacturer details and product information shall be submitted two weeks prior to installation and be approved in writing by the Engineer.

The Contractor shall furnish and operate these items as directed by the Engineer.

Installation shall follow the manufacturer's installation requirements.

### **Plastic Drum –Lighted, Furnish and Operate; Barricade Type III – Lighted, Furnish and Operate; Temporary Sign, Type B, Furnish and Operate; Channelizing Device, 42 Inch, Furnish and Operate; Pedestrian Type II Barricade, Temp**

The Contractor shall furnish and operate these items as directed by the Engineer.

Type II pedestrian barricades and type III barricades shall have standard orange-and-white stripes on both sides of the barricade.

Enough signs shall be provided by the Contractor to insure the safety of the workers and the general public in accordance with the current MMUTCD.

"Construction Ahead" warning signs shall be placed, as indicated on the Plans, or as directed by the Engineer, prior to the start of work, regardless of the nature, magnitude or duration of the work.

## **MEASUREMENT AND PAYMENT**

### **General**

All temporary traffic/pedestrian control devices furnished by the Contractor shall remain the property of the Contractor. The City shall not be responsible for stolen or damaged signs, barricades, barricade lights or other traffic maintenance items. The Contractor shall replace missing traffic control devices immediately, at no additional cost to the City.

Costs for transporting barricades and other traffic control devices shall be included in the bid prices for the individual items of work.

### **Pavt Mrkg Cover, Type R, Black**

Payment for Type R Black Pavt Mrkg shall be for the maximum quantity used on each street.

### **Pavt Mrkg, Type R, Tape**

Payment for Type R Tape shall be for the maximum quantity used on each street.

### **Temporary Curb for Bump-out**

Payment for Temporary Curb shall be for the maximum quantity used on each street.

### **Plastic Drum – Lighted, Furnish and Operate**

There will be a one-time payment for each street for the maximum number of lighted drums in-place (operated) at any one time, as directed by the Engineer.

**Barricade Type III – Lighted, Furnish and Operate**

Payment for furnishing and operating lighted type III barricades shall be for the maximum quantity in-place at any one time during the work of the entire project (all streets).

**Temporary Sign - Type B, Furnish and Operate**

Payment for Type B signs shall be for the maximum quantity used on each street.

**Channelizing Device, 42 Inch, Furnish and Operate**

There will be a one-time payment for each street for the maximum number of channelizing devices in-place (operated) at any one time, as directed by the Engineer.

**Pedestrian Type II Barricade, Temp**

Payment for furnishing and operating type II pedestrian barricades shall be for the maximum quantity in-place at any one time during the work of the entire project (all streets).

**Sign, Portable Changeable Message, Furnish and Operate**

Measurement for furnishing and operating portable changeable message signs will be for the maximum quantity in-place at any one time during the work of the entire project (all streets).

**Sign Cover**

There will be a one-time payment for each street for the maximum number of sign covers in-place (operated) at any one time, as directed by the Engineer.

The completed work as measured for these items of work will be paid for at the Contract Unit Price for the following Contract (Pay) Items:

<b><u>PAY ITEM</u></b>	<b><u>PAY UNIT</u></b>
Pavt Mrkg Cover, Type R, Black	Foot
Pavt Mrkg, Wet Reflective, Type R, Tape, 4 inch, White, Temp	Foot
Pavt Mrkg, Wet Reflective, Type R, Tape, 4 inch, Yellow, Temp	Foot
Pavt Mrkg, Wet Reflective, Type R, Tape, 6 inch Crosswalk	Foot
Pavt Mrkg, Wet Reflective, Type R, Tape, 24 inch Stop Bar	Foot
Temporary Curb for Bump-out	Foot
Sign, Portable Changeable Message, Furnish and Operate	Each
Plastic Drum - Lighted - Furnish& Operate	Each
Barricade Type III - Lighted - Furnish and Operate	Each
Temporary Sign, Type B	Square Foot
Channelizing Device, 42 inch, Furnish and Operate	Each
Pedestrian Type II Barricade, Temp	Each
Sign Cover	Each

**DETAILED SPECIFICATION FOR  
ITEM #277 – TEMPORARY PEDESTRIAN RAMP  
ITEM #278 – TEMPORARY PEDESTRIAN MAT**

**DESCRIPTION**

This work consists of furnishing, installing, maintaining, relocating, and removing a temporary pedestrian ramp as identified in the proposal or on the plans. Use temporary pedestrian ramps to facilitate pedestrian travel on accessible facilities over curbs or other uneven terrain features with a vertical difference of 1/2 inch or greater. Damaged pedestrian ramps will be replaced as directed by the Engineer.

**MATERIALS**

**A. Temporary Pedestrian Ramp**

Provide materials to construct a temporary pedestrian ramp in accordance with the *Americans with Disabilities Act (ADA)*, the standard specifications, and the following:

1. Ensure the material used to construct the temporary pedestrian ramp is firm, stable, skid resistant, and forms a continuous hard surface. Ensure the surface does not warp, buckle or otherwise become uneven, and materials support the weight of pedestrians as well as motorized scooters and wheelchairs. Suitable materials to construct the surface of the ramp include asphalt materials, Oriented Strand Board (OSB) or plywood, dimensional lumber, certain reclaimed or other materials as approved by the Engineer. Compacted soils, aggregate and sand are prohibited.
2. Provide a handrail on both sides of the ramp if the ramp is not exposed to vehicle traffic and has a total rise greater than 6 inches, and a length greater than 72 inches. Ensure the handrail is between 1.25 and 1.5 inches wide and configured to be a “graspable” cross-section. See construction subsection 2.A for additional details. When the ramp is exposed to traffic, in lieu of handrails, use a protective edge 2.5 inches minimum height above the ramp surface or 1:10 flare on both sides of the ramp.
3. Ensure the surface of the ramp is free draining; in addition provide features that allow drainage to move past the ramp installation (i.e. along the gutter pan underneath the ramp if the ramp is installed on a curb).
4. Provide materials to construct detectable edging along open sides of the ramp if required.
5. If asphalt materials are not used to construct the surface of the ramp, provide an antiskid coating or surface treatment approved by the Engineer.

**B. Temporary Pedestrian Mat**

Provide materials for a temporary pedestrian mat in accordance with the *Americans with Disabilities Act (ADA)*, the standard specifications, and the following:

1. Ensure the material used for the temporary pedestrian mat is firm, stable, skid resistant, and forms a continuous hard surface. Ensure the surface does not warp, buckle or otherwise become



uneven, and materials support the weight of pedestrians as well as motorized scooters and wheelchairs. Suitable materials will be determined by the Engineer after shop drawings or products information is provided.

2. Mats shall be at least 60 inches wide and not have traversable edges more than ½ inch high.
3. Ensure the surface of the mat is free draining.

### **CONSTRUCTION METHOD**

Construct the temporary pedestrian ramp in accordance with the manufacturer's recommendations (if applicable), *ADA*, the plans, and the following:

1. Ensure the useable surface of the ramp is 48 inches wide and does not deflect due to pedestrian traffic. Ensure an anti-skid surface treatment is applied to the useable area of the ramp if it is not made from asphalt materials. The maximum cross slope of the ramp is 2 percent. Ensure both ends of the ramp smoothly transitions to the adjacent surface, with 1/4 inch or less vertical difference.

Construct the ramp to maintain a longitudinal slope from 1:10 to 1:12 where possible. Otherwise, a longitudinal slope from 1:8 to 1:10 may be used for a maximum rise of 3 inches. Temporary pedestrian ramps with longitudinal slopes greater than 1:8 are prohibited.

- A. Provide a handrail on both sides of the ramp if required as stated herein. Ensure the top of the handrail is between 34 and 38 inches above the surface of the ramp. Ensure a minimum width of 36 inches is maintained between the handrails, with a minimum clearance of 1.5 inches behind and 18 inches above.

Construct the handrail such that the bending stress applied by a bending moment created by a 250 pound force is less than the allowable stress for the materials and the construction of the handrail. Construct the handrail to withstand the shear stress induced by a 250 pound force. Ensure all fasteners, mounting devices and support structures are also able to withstand shear stress induced by a 250 pound force.

2. Construct a detectable edging anytime a handrail is required, and anytime the path changes direction. This includes a turn onto the ramp from the path. Detectable edging must begin a maximum of 2.5 inches above the ramp surface, and extend at least 6 inches above the ramp surface.

3. Ensure a clear space (minimum 48 inches by 48 inches) is provided above and below the ramp.

4. Avoid locating ramps in areas of drainage collection, ponding or running water, which can produce slippery or unsafe conditions. If the ramp is located over a gutter pan or other drainage structure, provide features to facilitate water movement around or under the ramp as approved by the Engineer.

5. Ensure all debris and construction material is cleared from the surface of the ramp throughout its use. Ensure snow and ice is removed; the use of an approved de-icing agent may be required. Repair or replace the ramp if it becomes uneven, unstable, or displaces due to weather events, construction activities, or other causes as directed by the Engineer.

**MEASUREMENT AND PAYMENT**

The completed work, as described, will be measured and paid for at the contract unit price using the following pay item:

<b>Pay Item</b>	<b>Pay Unit</b>
Temporary Pedestrian Ramp.....	Each
Temporary Pedestrian Mat.....	Each

**Temporary Pedestrian Ramp and Temporary Pedestrian Mat** includes all labor, equipment, and materials to furnish, install and remove a temporary pedestrian ramp at the locations shown on the plans, as well as all costs for maintaining, clearing debris, deicing, reconfiguring, and relocating the temporary pedestrian ramps and mats throughout the life of the contract.

# **DETAILED SPECIFICATION FOR ITEM #279 – AUDIBLE MESSAGE DEVICE**

## **DESCRIPTION**

This work shall consist of furnishing and installing temporary audible message devices to be used in Temporary Pedestrian Alternate Routes (TPAR) for pedestrians with visual impairments in compliance with the latest version of the Michigan Manual on Uniform Traffic Control Devices (MMUTCD) and the Public Right-of-Way Accessibility Guidelines (PROWAG), published in November 2005. All work shall be in accordance with the Special Provision for “Maintenance of Traffic” and as indicated on the plans, and as modified herein.

## **CATEGORIES**

Audible message devices (AMDs) will have two categories:

1. AMDs without a pushbutton
  - These devices will operate based on a proximity sensor; the audible message content will be given when the sensor is activated.
2. AMDs with a pushbutton and locator tone
  - These devices will have the capability of utilizing a locator tone for pedestrians with visual impairments to locate the pushbutton on the AMD. The pushbutton on the AMD will activate the audible message content. The AMD may continuously sound the locator tone, or the locator tone may be activated with a proximity sensor.

## **CRITERIA**

Following are the necessary criteria for all types of AMDs to be on the APL:

- Compliant with the latest version of the Michigan Manual on Uniform Traffic Control Devices (MMUTCD) and the Public Right-of-Way Accessibility Guidelines (PROWAG), published in November 2005.
- Be weatherproof and fully operational between -20° F to +130° F and in a humidity range of 0-100% non-condensing.
- Be able to be battery operated.
- Proximity sensor shall be able to detect pedestrians from 15 feet away.
- The ability to verbalize a custom voice messages for a minimum of 60 seconds.
- Volume requirements
  - Volume measured at 3 feet from the AMD shall be 2 dB minimum and 5 dB maximum above ambient noise level in standard operations and shall be responsive to ambient noise level changes.
  - The ability to maximize volume at 100 dBA

Following are the additional necessary criteria for AMDs with pushbuttons and locator tones:

- The device shall be designed such that the pushbutton is within the Reach Ranges identified in PROWAG when the device is placed on level ground. In addition, the pushbutton shall be placed approximately at 42 inches (but no more than 48 inches) from the bottom of the device.
- Pushbuttons shall incorporate a locator tone at the pushbutton. Pushbutton locator tone volume

measured at 3.0 feet from the pushbutton shall be 2 dB minimum and 5 dB maximum above ambient noise level and shall be responsive to ambient noise level changes. The duration of the locator tone shall be 0.15 seconds maximum and shall repeat at intervals of one second. The locator tone may be activated by a proximity sensor.

## **MATERIALS**

Approved Temporary Audible Message Devices are as follows:

- Model 400ADA audible Device, manufactured by Empco-Lite, 1675 Shanahan Drive, South Elgin, IL USA 60177.
  - The 400ADA is an audible information device that can be mounted on various safety devices like the ADA Wall, 42" Cones, and the Safety Wall. Or it can just be a stand-alone device.
  - Easily program your message with built-in microphone and speaker.
  - Record up to a 60 second message.
  - Customize message for each location. See "Messages for Audible Information Devices" for message guidelines and helpful information.
  - When routes are blocked (especially mid-block closings), there are alternate crossings or alternate routes that are not continuous, these units provide positive guidance for the visually impaired by providing needed audible information. See 2009 MUTCD Section 6D.01 E, Section 6D.02, Section 6F.14, Section 6F.16 and notes on Figure 6H-28 and Figure 6H-29 (see PDF).
  - Unit can be mounted on a standard barricade light housing utilizing two 6V spring terminal batteries or can be a self contained unit operating on four D-Cell batteries.
  - Unit is triggered by motion detector when pedestrians get within 15 feet of the unit.
- SpeakMaster 500, manufactured by MDI Worldwide, 38271 W Twelve Mile Road, Farmington Hills, MI 48331.
  - The ADA SpeakMaster™ is an audible warning device that alerts pedestrians of a sidewalk closure ahead and provides navigation instructions Rugged design, simple to install and programmable through Bluetooth connectivity, the 9" DFB sign promotes safety where ever they're installed.
  - The all aluminum ADA SpeakMaster stands 5.5 feet high, is completely weather resistant, and ADA compliant. The two-sided frame at the top has snap-open side rails to easily change custom signs. The frame can rotate 360° to accommodate the different requirements of multiple urban areas. The unit is powered by an extended-life battery stored in a key-locked compartment in the base, and the base can be weighted for added stability and security. The electronics are housed in the upright, also in a key-locked compartment, and messages can be programmed on site, by cell phone, or computer. The base tilts and rolls on hidden wheels.
  - The ADA SpeakMaster is positioned approximately 100 feet before the actual sidewalk closure. As the pedestrian approaches, he hears a unique locator tone, which the visually impaired have been taught to recognize. The tone is either on continuously or is activated by an optional motion sensor and indicates that there is more information. The pedestrian locates the push button and activates the voice module to hear navigation instructions. He can then safely pass through the temporary pedestrian accessible route.

## **CONSTRUCTION METHOD**

Installer's Qualifications: Engage an experienced Installer who has successfully completed AMD installations similar in material, design, and extent to that indicated for this Project.

The contractor shall follow manufacturer specifications for installation, except where they conflict with MMUTCD or other project requirements.

**MEASUREMENT AND PAYMENT**

The completed work as measured for the following pay items will be paid for at the contract unit prices for the following contract items (pay items):

<b><u>PAY ITEM</u></b>	<b><u>PAY UNIT</u></b>
Audible Message Device	Each

The unit prices for this item of work shall include all labor, material, and equipment costs required to complete the work.

**DETAILED SPECIFICATION  
FOR  
ITEM #280 – FERTILIZER, CHEMICAL NUTRIENT, CL A  
ITEM #281 – MULCH BLANKET, HIGH VELOCITY  
ITEM #282 – SEEDING, MIXTURE THM  
ITEM #283 – TOPSOIL SURFACE, FURN, 4 INCH**

**DESCRIPTION**

This work shall consist of furnishing and installing turf restoration items to reestablish and permanently stabilize disturbed areas within the project as shown on the plans, including all labor, equipment, and material required.

This work shall be completed in accordance with the drawings and detailed specifications of this contract, the MDOT 2012 Standard Specifications for Construction, and as herein specified, including any detailed specifications

**MATERIALS**

The materials shall meet the requirements specified in the MDOT 2012 Standard Specifications as designated, as specified herein, and as approved by the Engineer:

- Seed shall be THM (Turf Loamy to Heavy) seed mixture as described in MDOT Table 816-1.
- Fertilizers shall be a Class A. The percentages by weight shall be 12- 12- 12, or as approved by the Engineer.
- Water used shall be obtained from fresh water sources and shall be free from injurious chemicals and other toxic substances.
- Mulch blankets shall be High Velocity Straw Mulch Blankets as specified in MDOT section 917.
- Topsoil shall be 4 inches furnished as specified in MDOT section 917

**CONSTRUCTION METHODS**

These items shall be constructed as required in the MDOT 2012 Standard Specifications for Construction. Mulch Blankets must be secured with materials that are biodegradable.

**MAINTENANCE AND ACCEPTANCE**

It is the responsibility of the Contractor to establish a dense lawn of permanent grasses, free from mounds and depressions prior to final acceptance and payment of this project. Any portion of a seeded area that fails to show a uniform germination shall be reseeded. Such reseeding shall be at the Contractor's expense and shall continue until a dense lawn is established. The Contractor is responsible for restoring all areas disturbed by his construction.

The Contractor shall maintain all lawn areas until they have been accepted by the Engineer. Lawn maintenance shall begin immediately after the grass seed is in place and continue until final acceptance with the following requirements:

Lawns shall be protected and maintained by watering, mowing, and reseeding as necessary, until the period of time when the final acceptance and payment is made by the Engineer for the project, to establish a uniform, weed-free, stand of the specified grasses. Maintenance includes furnishing and installing

additional topsoil, and reseeded all as may be required to correct all settlement and erosion until the date of final acceptance.

Damage to seeded areas resulting from erosion shall be repaired by the Contractor at the Contractor's expense. Scattered bare spots in seeded areas will not be allowed over three (3) percent of the area nor greater than 6"x 6" in size.

When the above requirements have been fulfilled, the Engineer will accept the lawn.

Restoration must be performed upon the completion of each stage of work, to prevent erosion, and not as one single operation at the completion of the entire project. Restoration work must be performed within one week of the placement of the wearing course for each street.

The Contractor shall restore all disturbed areas to better than or equal to their original condition.

### **MEASUREMENT AND PAYMENT**

The completed work as measured shall be paid for at the contract unit price for the following contract item (pay item):

<b><u>PAY ITEM</u></b>	<b><u>PAY UNIT</u></b>
Fertilizer, Chemical Nutrient, Cl A	Lbs
Mulch Blanket, High Velocity	Syd
Seeding, Mixture THM	Lbs
Topsoil Surface, Furn, 4 inch	Syd

All work indicated herein shall be included in the unit prices for the above pay items and shall include all labor, materials and equipment required to complete the work.

**DETAILED SPECIFICATION  
FOR  
ITEM #284 – FIRE HYDRANT ASSEMBLY**

**DESCRIPTION**

This Detailed Specification is intended to supplement the current City of Ann Arbor Standard Specifications for Construction with regard to Fire Hydrant Assembly.

**MATERIALS**

Fire hydrants shall be either the East Jordan Model Watermaster 5BR250 with traffic flange, or the Waterous Pacer Model WB67-250 with traffic flange. All fire hydrants shall have the following features: a 6 inch push-on tyton joint connection, ANSI/AWWA C111/A21.11; one 5 inch storz connection; one 3-3/8 inch threaded Ann Arbor Standard pumper connection with 7-1/2 threads per inch and 4.05 in. O.D.; 1-3/8 inch pentagon operating and cap nuts (1-3/8 in. point-to-flat at top; 1-7/16 in. point-to-flat at base); open left; breakable flange construction; no barrel drain; and a painted red finish. Depth of bury (bottom of pipe to ground surface) is generally 6 feet but may vary depending on specific site conditions. The pumper nozzles must be 21 in. ± 3 in. above finished grade, and the breakable traffic flange must be between finished grade and 8 in. above finished grade. Fire hydrant extensions for Waterous hydrants shall be Waterous Part # K562. Extensions for East Jordan hydrants shall be hydrant model 5BR250 extension kits. All fire hydrants must be certified by Underwriters Laboratory (UL) or the National Sanitation Foundation (NSF) for use in a potable water system.

**MEASUREMENT AND PAYMENT**

The unit price for this item of work shall include all labor, material, and equipment costs to perform all the work specified in the Standard Specifications and as modified by this Detailed Specification.

**PAY ITEM**

**PAY UNIT**

Fire Hydrant Assembly

Each

Fire hydrant assemblies shall be measured per unit constructed and paid for on the basis of unit price each. The unit price for fire hydrant assemblies shall include a 6-inch gate valve in box, 3 lineal feet of 6 inch pipe, an approved hydrant with traffic flange, and a thrust block. Any required extension will be paid for separately, on a per each installed basis.



**DETAILED SPECIFICATION FOR  
ITEM #285 – UNDERGROUND SPRINKLING SYSTEMS, RESTORE**

**DESCRIPTION**

Restore existing privately owned underground sprinkling systems within the project site as described herein. This work shall be paid with an allowance for the actual work required to restore and modify existing privately owned underground sprinkling systems. The Contractor shall take care to avoid disturbance of existing underground sprinkling systems within the project site. These typically will be encountered in the parkway adjacent to the roadway.

**MATERIALS**

Materials used to restore or modify existing underground sprinkling systems shall be of the same brand, model and specifications as the removed or damaged portion(s) of the sprinkling system and shall be compatible with the rest of the system.

**CONSTRUCTION METHOD**

The Contractor shall take precautions to prevent or minimize damage and disruption to private lawn sprinkling systems, including, but not limited to, completing visual inspections of the project site to determine areas in which lawn sprinkling equipment exists. This work of inspection shall be considered incidental to the disturbing work in the project area.

The Contractor shall repair or replace all lawn sprinkling systems disturbed by his/her operations and shall contact and coordinate any necessary work with the appropriate owners of such sprinkling systems. The Contractor shall obtain written permission from property owners prior to completing any work outside the R.O.W. on private property and shall provide copies of these documents to the Engineer for the project file.

The Contractor shall employ an underground sprinkling specialist to make necessary repairs or modifications to the affected underground sprinkling systems. During construction activities, the disturbed portions of the system shall be isolated and/or removed in such a way that the undisturbed portions of the system remain operational until the entire system is completely restored. The existing underground sprinkling systems shall be restored or modified so that spray from the sprinkler heads does not spray over sidewalks or into driving lanes of the road.

**MEASUREMENT AND PAYMENT**

The completed work shall be paid for at the contract unit price for the following contract item (pay item) which shall include all materials, equipment and labor required to complete this work.

<b>Pay Item</b>	<b>Pay Unit</b>
Underground Sprinkling Systems, Restore .....	Dollar

Payment for Underground Sprinkling Systems, Restore will be paid for as an allowance after all disturbed sprinkling systems have been repaired and/or replaced, whichever occurs later. The Contractor shall supply the Engineer with actual invoices from the underground sprinkling specialist for this work effort and may add up to 5% markup.

The Contractor waives all claim for damages or delay which he/she may suffer by reason of the presence of lawn sprinkling equipment within the project site and understands that no extra compensation will be paid to him/her due to any lawn sprinkling equipment encountered.

**DETAILED SPECIFICATION  
FOR  
ITEM #290 – CERTIFIED PAYROLL COMPLIANCE AND REPORTING**

**DESCRIPTION**

This specification covers all administrative requirements, payroll reporting procedures to be followed by Contractors performing work on City-sponsored public improvements projects, and all other miscellaneous and incidental costs associated with complying with the applicable sections of the City of Ann Arbor Code of Ordinances with regard to payment of prevailing wages and its Prevailing Wage Compliance policy.

This specification is not intended to include the actual labor costs associated with the payment of prevailing wages as required. Those costs should be properly incorporated in all other items of work bid.

**GENERAL**

The Contractor is expected to comply with all applicable sections of Federal and State prevailing wage laws, duly promulgated regulations, the City of Ann Arbor Code of Ordinances, and its Prevailing Wage Compliance Policy as defined within the contract documents. The Contractor shall provide the required certified payrolls, city-required declarations, and reports requested elsewhere in the contract documents within the timeline(s) stipulated therein.

The Contractor shall also provide corrected copies of any submitted documents that are found to contain errors, omissions, inconsistencies, or other defects that render the report invalid. The corrected copies shall be provided when requested by the Supervising Professional.

The Contractor shall also attend any required meetings as needed to fully discuss and ensure compliance with the contract requirements regarding prevailing wage compliance. The Contractor shall require all employees engaged in on-site work to participate in, provide the requested information to the extent practicable, and cooperate in the interview process. The City of Ann Arbor will provide the needed language interpreters in order to perform wage rate interviews or other field investigations as needed.

Certified Payrolls may be submitted on City-provided forms or forms used by the Contractor, as long as the Contractor's forms contain all required payroll information. If the Contractor elects to provide their own forms, the forms shall be approved by the Supervising Professional prior to the beginning of on-site work.

**UNBALANCED BIDDING**

The City of Ann Arbor will examine the submitted cost for this item of work prior to contract award. If the City determines, in its sole discretion, that the costs bid by the Contractor for complying with the contract requirements are not reasonable, accurately reported, or may contain discrepancies, the City reserves the right to request additional documentation that fully supports and justifies the price as bid. Should the submitted information not be determined to be reasonable or justify the costs, the City reserves the right to pursue award of the contract to the second low bidder without penalty or prejudice to any other remedies that it may have or may elect to exercise with respect to the original low-bidder.

The Contract Completion date will not be extended as a result of the City's investigation of the as-bid amount for this item of work, even if the anticipated contract award date must be adjusted. The only exception will be if the Contractor adequately demonstrates that their costs were appropriate and justifiable. If so, the City will adjust the contract completion date by the number of calendar days commensurate with the length of the investigation, if the published Notice to Proceed date of the work cannot be met. The

contract unit prices for all other items of work will not be adjusted regardless of an adjustment of the contract completion date being made.

**MEASUREMENT AND PAYMENT**

The completed work as measured for this item of work will be paid for at the Contract Unit Price for the following Contract (Pay) Item:

**PAY ITEM**

Certified Payroll Compliance and Reporting

**PAY UNIT**

Lump Sum

The unit price for this item of work shall include all supervisory, accounting, administrative, and equipment costs needed to monitor and perform all work related to maintaining compliance with the tasks specified in this Detailed Specification, the City of Ann Arbor Code of Ordinances, its Prevailing Wage Compliance policy and the applicable Federal and State laws.

Payment for this work will be made with each progress payment, on a pro-rata basis, based on the percentage of construction completed. When all of the work of this contract has been completed, the measurement of this item shall be 1.0 times the Lump Sum bid amount. This amount will not be increased for any reason, including extensions of time, extra work, and/or adjustments to existing items of work.

**DETAILED SPECIFICATION  
FOR  
ITEM #295 - 6-INCH WRAPPED EDGE DRAIN**

**DESCRIPTION**

This work shall consist of furnishing and installing 6-inch diameter geotextile-wrapped, perforated or slotted underdrain pipe, using MDOT 2NS, as directed by the Engineer, for all backfill material.

**MATERIALS**

The materials shall meet the requirements referenced in Section 404 of the 2012 edition of the MDOT Standard Specifications, except as specified herein.

The Geotextile Filter Fabric for encasing the underdrain pipe shall be an approved material such as nylon, polypropylene, fiberglass, or polyester, and shall be either woven, heat bonded, knitted, or of continuous fibers. The geotextile shall completely cover and be secured to the pipe. In an un-stretched condition, knitted polyester fabrics shall weigh at least 3.0 ounces per square yard, and all other geotextiles shall weigh at least 3.5 ounces per square yard. The fabric shall be strong and tough and have a porosity such that the fabric will retain soil particles larger than 0.106 mm (no. 140 sieve) and shall pass aggregate particles finer than 0.025 mm. Geotextiles shall be stored and handled carefully and in accordance with the both the manufacturer's recommendations and the Engineer's direction, and shall not be exposed to heat or direct sunlight. Torn or punctured geotextiles shall not be used.

**CONSTRUCTION METHODS**

Geotextile wrapped underdrain shall be installed as shown on the Plans or as directed by the Engineer and in accordance with Section 404 of the 2012 edition of the MDOT Standard Specifications, except as specified herein.

The installation of underdrain shall precede all other construction activities including but not limited to pavement milling, pavement pulverization, pavement removal, pavement patching, and curb repair.

The Contractor shall excavate, cut, remove stumps, remove brush, remove pavement, grade, and trim as needed and as directed, and shall import, furnish, fill, place, grade, and compact MDOT 2NS fine aggregate to construct underdrain as specified on the Plans, and as directed by the Engineer.

The trench shall be constructed to have a minimum width of 18-inches, and shall be typically excavated to the depth specified in the Plans or directed by the Engineer.

The underdrain shall be installed at the line, grade, and depth specified on the Plans or as directed by the Engineer. The minimum percent grade shall be 0.5%, and the minimum cover from top-of-pipe to finished top-of-curb grade shall be 4-feet. The Contractor shall maintain line and grade by means of a laser. The Engineer will not provide line, grade or staking.

Upgrade ends of the pipe shall be closed with suitable plugs to prevent entrance of trench backfill material. All couplings, tees, plugs, and other fittings shall be manufactured and installed so as to prevent any infiltration of trench backfill material.

The Contractor shall tap at least one end of the underdrain into a storm sewer structure, as directed by the Engineer.

During the construction of underdrain runs, the Engineer may direct the Contractor to terminate or modify underdrain construction due to conflicts with buried obstructions or if the minimum 4-foot cover cannot be maintained. There will be no adjustment to the Contract Unit Price due to changes in quantity.

The first lift (bedding) of backfill shall be MDOT 2NS material to a maximum thickness of 3-inches. Subsequent lifts shall be MDOT 2NS material to a maximum thickness of 12 inches.

Removed or excavated materials which are not incorporated into the work shall become the property of the Contractor and shall be immediately removed and properly disposed of off-site. Removed or excavated materials may not be stockpiled overnight on, or adjacent to, the site.

All structures, inlets and manholes shall be maintained free of accumulations of silt, debris, and other foreign matter throughout construction, until the time of final acceptance.

**MEASUREMENT AND PAYMENT**

Connecting (tapping) underdrain(s) into drainage structure(s) will not be paid for separately, but shall be included in the bid price for this item of work.

Underdrain will be measured in-place by length in lineal feet.

The completed work as measured for this item of work will be paid for at the Contract Unit Price for the following Contract (Pay) Item:

**PAY ITEM**

6-Inch Wrapped Underdrain

**PAY UNIT**

Foot

The unit price for this item of work shall include all labor, material, and equipment costs to perform all the work specified in the Standard Specifications and as modified by this Detailed Specification.

# APPENDIX

## **SOIL BORINGS**

- Report
- Barton Soil Boring

## **STANDARD CASTING SCHEDULE SD-GU-5**

- Sanitary Manhole Cover
- Storm Manhole Cover
- Water Manhole Cover

## TABLE OF CONTENTS

<b>1.0 INTRODUCTION</b> .....	<b>4</b>
1.1 General.....	4
1.2 Purpose and Scope.....	4
<b>2.0 SITE AND PROJECT CHARACTERISTICS</b> .....	<b>5</b>
2.1 Project Description.....	5
<b>3.0 INVESTIGATION PROCEDURES</b> .....	<b>6</b>
3.1 Field Investigation .....	6
3.2 Laboratory Testing .....	6
<b>4.0 GENERAL SUBSURFACE CONDITIONS</b> .....	<b>7</b>
4.1 Soil and Groundwater Conditions.....	8
4.1.1 Summary .....	8
4.2 Groundwater Conditions .....	9
<b>5.0 ANALYSIS AND DESIGN RECOMMENDATIONS</b> .....	<b>10</b>
5.1 Site Preparation .....	10
5.2 Fill Materials and Compaction .....	11
5.3 Support of Pavement .....	12
<b>6.0 GENERAL CONSTRUCTION PROCEDURES AND RECOMMENDATIONS</b> .....	<b>13</b>
6.1 General.....	13
6.2 Utility Excavations.....	13
6.3 Groundwater Control.....	14

### Appendix

- ❖ Boring Location Maps
- ❖ Soil Boring Logs
- ❖ General Notes for Soil Classification



## 1.0 INTRODUCTION

### 1.1 GENERAL

This report presents the results of the geotechnical investigation performed by CTI and Associates, Inc. (CTI) as part of the 2019 Miscellaneous Geotechnical Services Contract. A total of 35 soil borings and 23 pavement cores were completed through City of Ann Arbor (City) streets. The number, depth, and locations of the soil borings were selected by the City. This report presents the results of CTI's findings and an engineering interpretation of these findings with respect to the soil related phases of the project including estimates of resilient moduli to be used for pavement design.

In general, soils encountered at several locations will require preparation as outlined in Section 5 of this report to be able to support new pavement. The soils encountered at some of these locations were found to have deficiencies and it is advisable that they be undercut and replaced as discussed in this report. Recommendations for the construction observation and preparation of the encountered subgrade soils to improve their suitability for pavement construction are included in the report sections that follow. Table 2 of the report identifies borings where conditions requiring special attention, such as very loose, soft, or very wet soils were encountered.

CTI's evaluation was performed in general accordance with the scope of services outlined in CTI Proposal No. 116PR02040-137 dated January 17, 2017 and the Professional Services Agreement between the City of Ann Arbor and CTI dated March 6, 2017.

### 1.2 PURPOSE AND SCOPE

The purpose of this study was to determine the general subsurface conditions beneath each street by drilling test borings and to evaluate the encountered soils for suitability with respect to pavement support, drainage, and utility support. Specifically, the report presents our evaluations and recommendations regarding the following items:

- A. General subsurface (soil and groundwater) conditions at the site.
- B. Design recommendations, specifically pavement design parameters including estimates of resilient moduli of encountered soils.
- C. Construction recommendations including include site preparation and earthwork operations, groundwater conditions and controls, potential construction problems and recommendations regarding quality control during construction.

The evaluations and recommendations discussed in this report are based on the soil conditions encountered in the test borings performed at the specific boring locations, and on the date indicated on the boring logs. The soil conditions may vary at locations other than the actual soil boring locations. These variations may not become evident until the time of construction.

If variations in the reported soil conditions are encountered, CTI should be contacted immediately. In such a case, it may be necessary for CTI to reevaluate the recommendations of this report. Such a reevaluation may be possible from on-site observations or may require additional investigations. If any such variations are revealed, they may result in increased construction costs. A contingency should be provided in the project budget to accommodate such variations.

CTI's authorized scope of services included a geotechnical study of the subject site and did not include an environmental assessment for determining the presence or absence of hazardous or toxic materials in the soil or groundwater at, below or around the site. The presence or absence of contaminated material is

not implied, inferred, or suggested by this report or the results of this study. Any statement contained within this report or presented on the soil boring logs regarding odors, colors, or unusual items are strictly for informational purposes only. If any recognized environmental concerns are identified for this site, the evaluations and/or recommendations presented in this report may require amendment.

## 2.0 SITE AND PROJECT CHARACTERISTICS

### 2.1 PROJECT DESCRIPTION

CTI was awarded the 2019 Miscellaneous Geotechnical Services bundle on May 30, 2019. The bundle included a total of 49 boring locations and 23 pavement cores on 6 different streets within the City. The proposed boring locations were marked in the field by City personnel prior to field activities. Following the boring location marking by the City, CTI requested the Miss Dig service to locate the existing underground utility locations at each boring location. Several borings were offset from the marked locations due to conflicts with underground utilities, overhead obstructions (trees and overhead electric lines), and/or to maintain traffic flow. Four locations on Plymouth road were not drilled due to underground utility conflicts. Pavement cores were performed at these locations instead. Table 1 presents the specific breakdown of the number of requested borings per street, the boring depths, and the limits of exploration. All the completed soil borings were located within the streets.

**Table 1.** Summary of requested soil borings

Street	Cross Streets	No. of Borings	No. of Pavement Cores	Depth (ft)	Abbreviation*
Barton Drive	M14 Entrance Ramp to Brede Place	6		20	BAR
Barton Drive	Brede Place to Pontiac Trail	4		5	BAR
Plymouth Road	Upland Drive to Nixon Road	13**	12**	5	PLY
S. Industrial Highway	E. Stadium Blvd. to E. Eisenhower Parkway	6	11	10	IND
Hollywood Drive	Alison Drive to N. Maple Road	2		25	HOL
Hollywood Drive	Alison Drive to N. Maple Road	2		5	HOL
First Street	Kingsley Street to Liberty Street	5		10	FIR
First Street	Liberty Street to Madison Street	3		5	FIR
Ashley Street	Kingsley Street to Washington Street	4		10	ASH
Ashley Street	Washington Street to Madison Street	4		5	ASH
<b>Total</b>		<b>49</b>	<b>23</b>		

\*Note: this abbreviation is used throughout the report and appendices to aid the reader in correlating the results of the field and laboratory tests and observations.

\*\*Note: Four boring locations on Plymouth road were not completed due to utility conflicts. Pavement cores were performed at these locations instead.

The recommendations presented in this report are based on the provided and/or assumed project information and the results of our geotechnical exploration. If any of the above noted project information is considered incorrect or is changed, CTI should be informed in writing so that a review can be performed and any necessary revisions to our recommendations can be made.

## 3.0 INVESTIGATION PROCEDURES

### 3.1 FIELD INVESTIGATION

CTI's field investigation consisted of drilling 45 soil borings and 27 pavement cores through 6 different streets within Ann Arbor City limits. The approximate as-drilled locations of the borings are listed on the boring location maps, included in the appendix of this report. As requested, the borings were extended to different depths below the top of pavement as shown in Table 1.

Several boring locations were in conflict with overhead and underground utilities and were relocated as a result. Borings were relocated in a way that maintained proper coverage (i.e., boring spacing) of the investigated area to the extent possible.

The borings were located in the field by City personnel prior to the drilling activities. The drilling operations were performed under direction of CTI personnel between July 22 and August 7, 2019. Prior to drilling the soil borings, the pavement structure was explored with a core drill equipped with six-inch nominal diameter core barrels. After extraction of the cores at each location, when possible, the core samples were measured and labeled. The soil borings were then drilled with a truck-mounted drill rig using hollow stem augers. Soil samples were obtained at 2.5-foot-intervals by the Standard Penetration Test Method (ASTM D1586), whereby a 2-inch outside diameter split-barrel sampler is driven into the soil with a 140-pound weight falling freely through a distance of 30 inches. The sampler is generally driven three successive 6-inch increments, with the number of blows for each increment being recorded. The number of blows required to advance the sampler from 6 to 18 inches is termed the Standard Penetration Resistance, N.

The soil samples obtained with the split-barrel sampler were sealed in glass jar containers and transported to our laboratory along with the retrieved pavement core samples for further classification and testing. After completion of the drilling operations, the boreholes were backfilled with excavated soil (i.e., auger cuttings) and disturbed pavement patched with a cold asphalt patching mix.

Soil and groundwater conditions observed in the test borings have been evaluated and are presented on the boring logs included in the Appendix. To aid in understanding the data presented on the boring logs, "General Notes for Soil Classification," describing nomenclature used in soil descriptions, are also included in the Appendix. It should be noted that the soil descriptions reported on the test boring logs are based upon field logs prepared by experienced drillers with modifications made based on the results of laboratory testing and engineering review.

### 3.2 LABORATORY TESTING

The laboratory testing program was directed towards determining the general soil classification and physical properties of the soil pertinent for pavement design and site preparation. All laboratory testing was performed in general accordance with applicable ASTM test method standards. The laboratory testing consisted of visual soil classification of every sample and natural moisture content testing of cohesive soil samples. The unconfined compressive strength of selected cohesive samples was also estimated based on the resistance to a calibrated spring-loaded hand penetrometer. At the time of the preparation of this report, no further lab testing was requested by the City.

The soil samples were visually classified in general accordance with the Unified Soil Classification System (USCS). The estimated USCS group symbol is shown in parentheses following the written description of the various strata on the boring logs. The results of all laboratory tests are indicated on the boring logs at the depths the samples were obtained and/or on the "Summary of Laboratory Test Results" included in the Appendix.

## 4.0 GENERAL SUBSURFACE CONDITIONS

The following paragraphs present generalized soil and groundwater conditions encountered at the subject site based on the available test borings.

**Ashley Street:** The pavement encountered on Ashley street consisted of approximately 3 ½ to 6 inches of asphalt. At 2 locations, a layer of concrete ranging in thickness from 7 to 7 ¾ inches was encountered. The subgrade material mostly consisted of very loose and loose sands which will require improvement as outlined in Section 5 of this report.

**First Street:** The pavement encountered on Ashley street consisted of approximately 2 ½ to 6 ¾ inches of asphalt. At 4 locations, a layer of concrete ranging in thickness from 6 to 7 ½ inches was encountered. The subgrade material mostly consisted of sands except at FIR-02 and FIR-08 where it consisted of clay. The subgrade materials encountered south of Liberty street were mostly classified as loose, indicating that they will require improvement as outlined in Section 5 of this report.

**Barton Drive:** The pavement encountered on Barton drive consisted of approximately 4 to 6 inches of asphalt. Medium dense Sand was mostly encountered below the pavement surface which may not require additional special preparation to support new pavement. At the locations of BAR-09 and BAR-10, medium stiff clay and sandy clay were encountered below the pavement which may increase the risk of decreased pavement life and serviceability if not addressed using the preparation methods presented in Section 5.

**Hollywood Drive:** Hollywood drive is an unpaved road consisting of 6 inches to approximately 2 feet of sandy road material. The underlying material mostly consisted of clay and silty clay. At HOL-04, soft to stiff clays were encountered starting at 3 ½ feet below ground surface which would require improvement as outlined in Section 5 of this report.

**S. Industrial Highway:** The pavement thickness on Industrial highway ranged from approximately 8 inches to 11 inches of concrete. The pavement at IND-05 and IND-06 consisted of approximately 4 inches of asphalt. Sand was encountered under the pavement in most locations and was generally in a medium dense condition suggesting they may not require special improvement to be able to support new pavement. At IND-01, very loose sands were encountered at a depth of 2 ½ feet.

**Plymouth Road:** The pavement on Plymouth consisted of approximately 4 to 9 ½ inches of asphalt. At all locations in the two eastbound lanes (east of PLY-C-5), concrete was encountered under the asphalt. The thickness of the concrete ranged from 7 ¾ inches to 10 inches. The subgrade material was mostly clay and silty clay and was mostly found to have soft to medium stiff consistencies east of Traverwood Dr which will require preparation as outlined in Section 5 of this report.

Table 2 below identifies areas where conditions requiring special attention were encountered. For a more detailed description of the subsurface conditions encountered at the site, please refer to the individual soil boring logs and the Boring Location Plan provided in the appendix.

**Table 2. Areas requiring special attention**

Boring Number	Notes
ASH-10	Soft clays encountered near surface
ASH-13	Very loose sands encountered near surface
ASH-14	Soft clays encountered near surface
ASH-15	Soft clays encountered near surface
ASH-16	Very loose sands encountered near surface
FIR-02	Soft clays encountered near surface
FIR-07	Very soft clays encountered at 3.5 feet depth
IND-01	Very loose sands encountered at 2.5 feet depth
PLY-09	Soft clays encountered near surface

#### 4.1 SOIL AND GROUNDWATER CONDITIONS

##### 4.1.1 Summary

The above subsurface description is of a generalized nature and is intended to highlight the major stratification features and material characteristics. The individual test boring logs should be reviewed for specific information. The stratification depths shown on the test boring logs represent the soil conditions at the actual boring locations only. Variations may occur between and/or beyond the boring locations. The nature and extent of any variations may not become evident until the time of construction. If significant variations in the soil conditions are discovered during construction, it should be immediately brought to the attention of CTI, before removal.

Table 3 below presents a summary of the encountered subgrade conditions in addition to an estimate of the resilient modulus of the subgrade materials, located under the existing road base at each location. These estimates are based on the assumption that the base material will be removed, and the subgrade will be prepared according to the recommendations presented in Section 5. If the City decides to reuse part or all of the existing base material, leaving the subgrade in its current condition, CTI should be informed of the proposed design to determine if it will be necessary to revise the values given below.

**Table 3.** Summary of subgrade conditions at explored locations

Street	No. of Borings	Depth (ft)	Asphalt Pavement Thickness (in)	Concrete Pavement Thickness* (in)	Base Thickness (in)	Base Type	Subgrade Soil Description	Estimated Resilient Modulus, Mr (ksi)**
Barton Drive	10	5-20	4-6	N/A	4-6	Sand with gravel / crushed asphalt	Fine to coarse sand with amounts of clay	11
Plymouth Road	13	5	4-9.5	7.75-10	3-12	Sand / gravel	Clay and silty clay	6
S. Industrial Highway	6	10	3.75-4	8-11	6-12	Sand with gravel	Sand and silty sand with varying small amounts of clay and gravel	10
Hollywood Drive	4	5-25	N/A	N/A	N/A	Sand with gravel	Clay and silty clay with small amounts of sand	5
First Street	8	5-10	2.5-6.75	6-7.5	5-6	gravel / sand	Fine to coarse sand Clay in 2 locations	11
Ashley Street	8	5-10	3.5-6	7-7.75	0-18	Sand with gravel	Fine to coarse sand with amounts of clay	10

\*Note that concrete was not found in all boring locations

\*\*Note: The resilient modulus values were conservatively estimated based on the classification of the subgrade material using correlations presented in the Federal Highway Administration Geotechnical Aspects of Pavements Reference Manual

#### 4.2 GROUNDWATER CONDITIONS

The drillers looked for indications of groundwater seepage both during and upon completion of the drilling operations. Groundwater seepage was not observed within any of the test borings either during or after drilling. During drilling, water was encountered at relatively shallow depths (less than 5 feet) in one boring on Barton drive (BAR-4), one boring on Plymouth road (PLY-12), and two borings on Industrial Highway (IND-02 and IND-04). After drilling, water was observed in 9 borings at depths ranging from 3.7 to 7.8 feet below the top of pavement.

The short-term groundwater level observations from the borings are not necessarily indicative of the static, long-term groundwater conditions. The groundwater conditions discussed herein and indicated on the soil boring logs represent those encountered at the time of the field investigation. The groundwater levels, including perched groundwater accumulations, should be expected to fluctuate seasonally, based on variations in precipitation, evaporation, surface run-off and other factors not evident at the time of our investigation. Typically, groundwater levels and volumes are expected to be higher in the winter and spring seasons compared to the summer and fall months. The actual groundwater levels at the time of construction may vary from those provided herein.

The above soil and groundwater conditions represent a generalized summary of the subsurface conditions and material characteristics. The individual Test Boring Logs should be reviewed for specific information and details relating to specific areas of the site.

## 5.0 ANALYSIS AND DESIGN RECOMMENDATIONS

At the time this report was prepared, the overall project was in the planning and design stage. The following recommendations have been developed based on the previously assumed/described project characteristics and subsurface conditions. If there is any significant change in the project characteristics from those presented earlier, a review should be made by CTI to determine if any modifications in the evaluations and recommendations included in this report will be required.

In general, soils encountered near the surface (shallower than 5 feet) in the several of the locations will require preparation as outlined in this section in order to be able to support new pavement. For the purpose of this report, these soils were identified for improvement using the following criteria:

- Are granular and classified as having loose or very loose relative density ( $N < 11$ )
- Are cohesive and exhibit an unconfined compressive strength less than 4000 psf when tested with a pocket penetrometer
- Contain organic material

Based on the above criteria, soils on Ashley Street, First Street (south of Liberty Street), Hollywood Drive, and Plymouth Road (east of Traverwood) will require improvement as discussed in the following sections. Regardless if improvement is needed or not, general site preparation methods presented in the following sections should be applied to develop a suitable subgrade for the placement of pavement materials. CTI assumes that the full existing pavement section including the base material will be removed to allow the preparation of the subgrade. If the owner is willing to assume the risks related to decreased pavement life/serviceability, some of this material could be left in place. However, CTI must be notified to determine if any modifications in the estimated resilient modulus value is necessary. It is advisable that the inadequate soils encountered at locations described in Table 2 above be undercut and replaced as discussed in Section 5.1 as the soils at these locations were found to be very loose or soft.

### 5.1 SITE PREPARATION

At the start of earthwork operations, all existing pavement and any deleterious material should be removed in their entirety from the new pavement areas. The thickness of the existing pavement, aggregate base and near surface fill layer (where present) should be expected to vary across the site. The depth of unsuitable soil to be removed should be determined by CTI at the time of stripping and rough grading. A CTI representative should also be on-site during the subgrade preparation operations to determine the suitability of the subgrade for pavement support.

The subgrade soils should be evaluated and prepared during construction as follows. After rough grade has been achieved in cut areas and prior to fill placement in fill areas, the exposed subgrade should be thoroughly proofrolled. Proofrolling should be performed with a heavily loaded front-end loader, tandem-axle dump truck or other suitable rubber-tired vehicles. The purpose of the proofrolling operations is to locate localized areas of excessively loose, soft or weak subgrade soils which may be present at the time of construction. Soils that are observed to rut or deflect excessively during proofrolling should be removed or stabilized by conventional methods such as disking, drying, and re-compacting. The loose sands encountered in the majority of the boring locations can be improved using these methods. Note that these conditions may exist elsewhere between borings.

If it is not feasible to dry and re-compact the unsuitable subgrade soils due to unfavorable weather conditions, scheduling, etc., it may be necessary to remove such soils and replace them with engineered fill. The thickness of the undercut will depend on the severity of the unstable soils encountered at specific locations. If significant subgrade instability is observed, a layer of crushed aggregate may be necessary to

stabilize the subgrade before placement of the selected engineered fill material. The use of a woven geotextile below the crushed aggregate layer could also be considered to provide additional subgrade stability.

It should be noted that the actual locations and depths of any undercutting and/or stabilization should be established in the field at the time of construction. The extent to which yielding subgrades may be a problem is difficult to predict beforehand since it is dependent upon several factors including seasonal conditions, precipitation, construction practices, etc.

Once the site has been evaluated, proofrolled, and/or stabilized, the inspected area should not be allowed to remain exposed more than one day or to appreciable precipitation or other wet conditions. It should also not be subjected to construction traffic, otherwise a re-evaluation should be made. The site earthwork operations should be carried out during a period of dry weather, if possible. This should minimize potential subgrade problems, although they may not be eliminated. The severity of subgrade instability will depend to a high degree on the weather conditions prevailing during construction.

## 5.2 FILL MATERIALS AND COMPACTION

After subgrade preparation and observation have been completed, engineered fill placement may begin. Any fill placed below the proposed pavement area should be an approved material that is free of topsoil, organics, frozen soil or any other unsuitable material.

If clay soils or granular soils containing greater than 12 percent clay are used as fill, close moisture content control will be required to achieve the recommended degree of compaction. Cohesive fill materials should be low to medium in plasticity, with a liquid limit less than 40 and plasticity index less than 20. Wet cohesive soils are difficult to compact and the specified compaction may not be achieved. Wet cohesive soils may require drying or mixing with dry soil to facilitate compaction. If water must be added to dry soil, it should be uniformly applied and thoroughly mixed into the soil by disking or scarifying.

The engineered fill should be placed in uniform horizontal layers not exceeding 8 to 12 inches in loose thickness for clean granular soils and 4 to 6 inches in loose thickness for clay soils (or clayey granular soils exhibiting cohesive characteristics), depending on the type and size of compaction equipment used. The lift thickness for sands that have an appreciable amount of fines (i.e., silt or clay) should be decreased accordingly. The engineered fill should be compacted to achieve a density of not less than 95 percent of the maximum dry density as determined by the Modified Proctor Compaction Test (ASTM D1557). Also, the upper 12 inches of the subgrade soils should be compacted, prior to any fill placement, to achieve a density of not less than 95 percent of the maximum dry density as determined by the Modified Proctor test. The as-compacted moisture content of the engineered fill should be within 2 to 3 percent of the optimum moisture content for the soil. The placement and testing of engineered fill should be observed and properly documented in the field by CTI.

We recommend that the contract specifications include provisions for moisture conditioning of any on-site soils that are to be used as engineered fill. Some of the native soils may require moisture conditioning to allow for proper compaction. The success of aeration and drying of clay soils will be dependent on the time of year, the prevailing weather conditions and the contractor's effort. During cold and/or wet periods of the year, the saturated or disturbed clay soils will be more difficult to dry. In this case, the contractor may have to use drier on-site soils or imported sand.

If site grading or other construction activity is planned during cold weather, it is recommended that proper winter construction practices are followed. All snow and ice should be removed from cut and fill areas prior to grading. Frozen materials should not be used as engineered fill and no fill, footings, slabs or pavement should be placed on soils that are frozen or contain frozen material.



### 5.3 SUPPORT OF PAVEMENT

The subgrade soils should be prepared in accordance with the methods presented in Section 5.1 of this report for support of the pavement sections. Special attention should be paid to the areas of concern mentioned in Section 5.0 and Table 2. As discussed previously, we recommend the subgrade be subjected to a comprehensive proofrolling and evaluation program to determine the overall suitability at the time of construction. The areas requiring subgrade improvement should be determined in the field by CTI through proper inspection and evaluation at the time of construction. Provisions should be established in the construction documents for this purpose.

The long-term performance of the pavement will typically be a function of the quality of the subgrade soil at the time of construction along with the quality, thickness and strength of the overall pavement section. The most critical portion of the subgrade is the 3-4 feet immediately beneath the pavement section, which provides the primary strength needed for pavement section support. Beyond that, the impact of poor soils then starts to diminish with depth. Soils in a saturated condition, uncontrolled fill and/or organic materials present within the upper 2 to 3 feet of the pavement subgrade can be detrimental if the design does not account for this substandard soil condition, especially during the spring freeze-thaw cycles.

The pavement system should be properly drained to reduce the potential for weakening the subgrade. Provisions should be made to prevent surface run-off water from accumulating within the aggregate base course of the pavement. The pavement and underlying subgrade should be suitably crowned or sloped to promote effective surface drainage and prevent water ponding.

We anticipate that the pavement surface will drain via storm sewers (where present) and via run-off methods where storm sewers are not available. Where the reconstruction project includes the installation of a storm sewer system in clay soils, finger drains should be installed at all catch basin locations to provide drainage for surface water that may become trapped in the pavement aggregate base course. At a minimum, a system of finger drains or stub drains should be placed around all catch basins within the pavement areas to minimize the accumulation of water in the frost susceptible subgrade soils. These under drains should be installed below the aggregate base course layer of the pavement system and be properly protected with free-draining coarse aggregate material and filter fabric.

All pavements require regular maintenance and occasional repairs to keep them in a serviceable condition. Of particular value is timely sealing of joints and cracks, which if left un-repaired, can serve to permit water to enter the pavement section and cause rapid deterioration of the pavement during freeze-thaw cycles. The need for such routine maintenance and repair is not necessarily indicative of premature pavement failure. However, if appropriate maintenance and repairs are not performed on a timely basis, the serviceable life of the pavement can be reduced significantly.

Actual pavement section thickness should be provided by the design civil engineer based on design traffic loads and volume and the owner's design life requirements. All pavement materials and procedures should conform to standard MDOT and City of Ann Arbor requirements.

Based on the results of the soil borings performed, Resilient Modulus values ( $M_r$ ) for the encountered soils have been estimated and are presented in Table 3, along with a summary of the encountered pavement and subgrade conditions. The resilient modulus values were conservatively estimated based on the classification of the subgrade material using correlations presented in the Federal Highway Administration Geotechnical Aspects of Pavements Reference Manual

## 6.0 GENERAL CONSTRUCTION PROCEDURES AND RECOMMENDATIONS

### 6.1 GENERAL

Experience indicates that variations in soil conditions are encountered during construction. In order to permit correlation between the soil boring data and the actual soil conditions encountered during construction, it is recommended that a continuous inspection and review of the soil related phases of construction work be carried out. We recommend the site preparation activities, engineered fill placement and foundation construction be observed by a qualified engineering technician. The technician should perform the appropriate type and number of field tests needed to verify compliance with construction specifications and that the pavement subgrade soils are suitable.

The existing clayey soils found in various boring locations noted above could be potentially troublesome for some earthwork operations, depending on the prevailing moisture content. These soils have relatively poor drainage characteristics and are susceptible to ponding, subsequent softening and pumping due to construction traffic. During a wet season or periods of heavy precipitation, the silty and clayey subgrade soils may become unstable and provide limited support for some rubber-tired construction equipment. If pumping of the subgrade occurs due to construction traffic, an evaluation of the site and construction procedures should be made by a geotechnical engineer.

### 6.2 UTILITY EXCAVATIONS

In general, all excavations should be safely sheeted, shored, sloped or braced in accordance with OSHA guidelines. Construction traffic, stockpiles of soil and construction materials should be kept away from the edges of the excavations a lateral distance at least 1.5 times the depth of the excavation.

Utility excavations are generally expected to consist of open-cut methods. In this regard, the utility trench sidewalls should be adequately braced or sloped back to prevent sloughing and caving. In any case, appropriate measures will be required to maintain the stability of excavation sidewalls. The required measures will depend on the depth and width of excavations and groundwater conditions at specific locations. The excavation support system for utilities could consist of internally braced sheeting, trench boxes or sliding trench shields. If material is stored or equipment is operated near an excavation, stronger shoring must be used to resist the extra pressure due to the superimposed loads.

The angle of the excavation side slopes should be decided based on the soil type and unconfined compressive strength of the excavated soil per MIOSHA requirements. For excavations greater than 5 feet and less than 20 feet in depth, MIOSHA has different sloping requirements for a variety of soil types. The table presented below provides a summary of the requirements for informational purposes only. Prior to designing or constructing a stable and safe excavation, the contractor must refer to MIOSHA standards.

**Table 4. Maximum Allowable Angle of Repose for the Side of an Excavation**

Soil Type	Maximum Allowable Excavation Side Slope		Maximum Angle of Repose (Degrees)
	Horizontal	Vertical	
Clay with minimum unconfined compressive strength of 2.5 tsf	1	2	63
Clay with minimum unconfined compressive strength of 1.5 tsf	2	3	56
Clay with minimum unconfined compressive strength of 1.0 tsf; Dry granular soils; Dry sand and clay mixtures	1	1	45
Granular soil with wet clay or silt seams; Clay with a minimum unconfined compressive strength of 1.0 tsf that contains running sand seams	1½	1	34
Saturated granular soil; Clay with an unconfined compressive strength less than 1.0 tsf	2	1	26
Running/sloughing soil (sand or clay)	3	1	18

Soils exposed in the bases of all satisfactory excavations should be protected against any detrimental change in conditions such as disturbances from rain and freezing. Surface run-off water should be drained away from the excavations and not allowed to pond. If possible, all utilities should be placed the same day the excavation is made. If this is not possible, the footing excavations should be adequately protected.

### 6.3 GROUNDWATER CONTROL

Based on the observed groundwater conditions in the test borings, no significant groundwater related problems are anticipated during pavement construction. However, the conditions encountered at the majority of the boring locations are conducive to the development of perched water accumulations within the granular soils. If perched accumulations occur, some groundwater seepage could be encountered.

Proper groundwater control measures should be maintained during all earthwork activities in order to limit the disturbance of the subgrade soils. These measures should include a provision of temporary drainage ditches to discharge any perched water outside the construction area. For relatively shallow excavations, it appears that minor perched groundwater accumulations, if encountered, should be controllable by conventional pumping methods from standard sump pits extending into the natural clay soils.

Any groundwater related problems should be evaluated in the field by a qualified geotechnical engineer so that the best remedial measures can be determined.



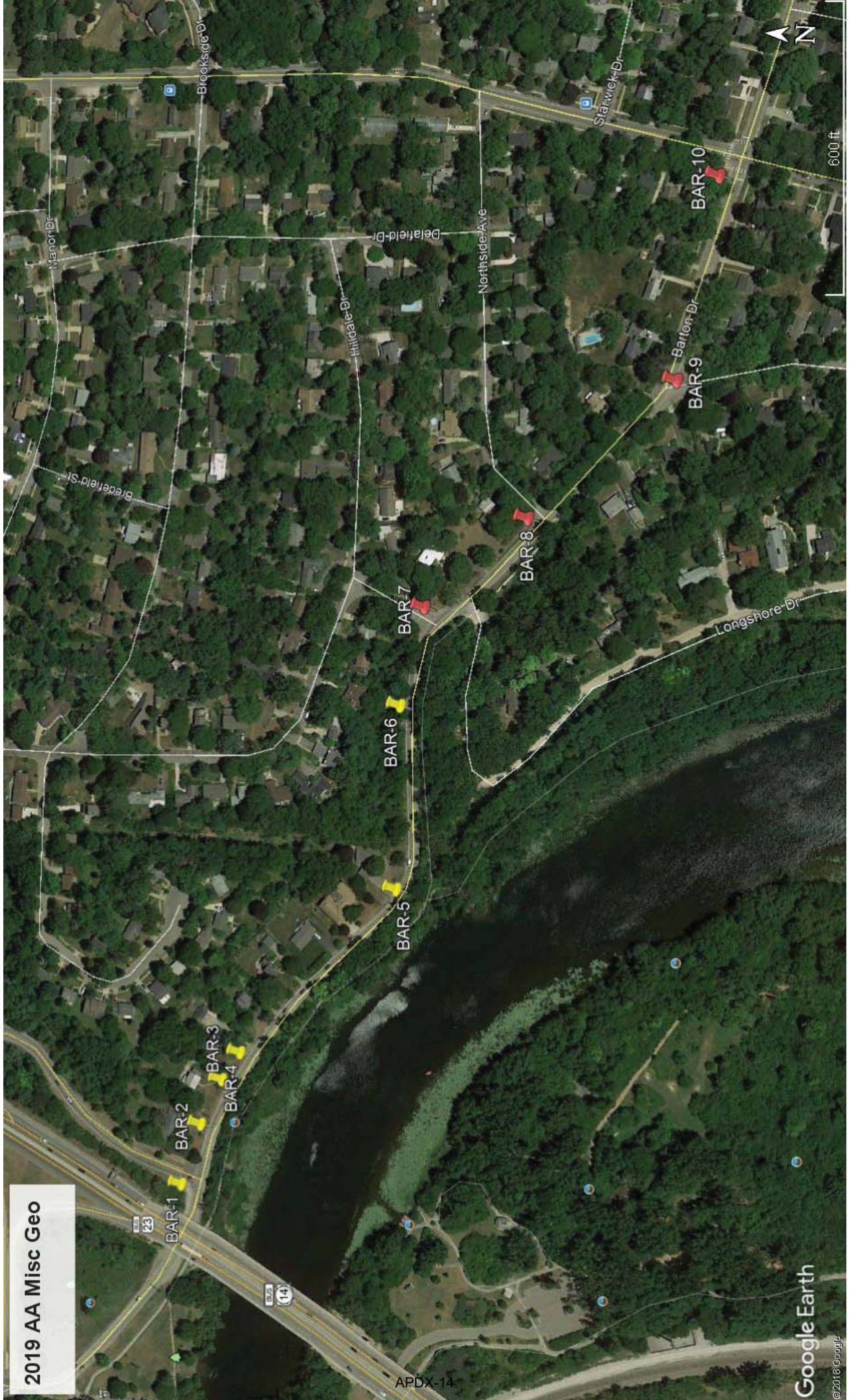





Project Number: 1198070026  
 Project Name: City of Ann Arbor  
 Misc Geotechnical Services  
 Project Location: Ann Arbor, MI  
 Client Name: City of Ann Arbor  
 Date Started: 7/31/19 Completed: 7/31/19  
 Time Started: Completed:  
 Logged By: Al Guzdial Checked By: K. Matsuda

Boring No: BAR-01  
 Longitude: Latitude:  
 Surface Elevation (ft):  
 Drilling Firm: BRAX Drilling  
 Driller Name: Al Guzdial  
 Drilling Method: HSA  
 Drill Rig Model:  
 Auger Size: 3.25"  
 Weather:

DEPTH (ft)	DESCRIPTION OF STRATA	LEGEND	SAMPLE	RECOVERY (in)	BLOW COUNTS (N VALUE)	UCS (tsf)	Soil Properties		
							PL	MC	LL
0	6 inches of ASPHALT pavement	[Solid Black]							
	4 inches of CRUSHED ASPHALT base	[Cross-hatch]							
	SAND (SP) - brown, fine to coarse, with gravel, trace clay, loose, moist	[Dotted]	SS-1		8-11-7 (18)				
5			SS-2		5-3-3 (6)				
	SAND (SP) - brown, fine to medium, with gravel, trace silt, medium dense, wet	[Dotted]	SS-3		14-10-7 (17)				
10			SS-4		13-15-18 (33)				
15	SILTY CLAY (CL) - brown, trace gravel, hard, moist	[Diagonal Lines]	SS-5		13-18-14 (32)	4.5 +			

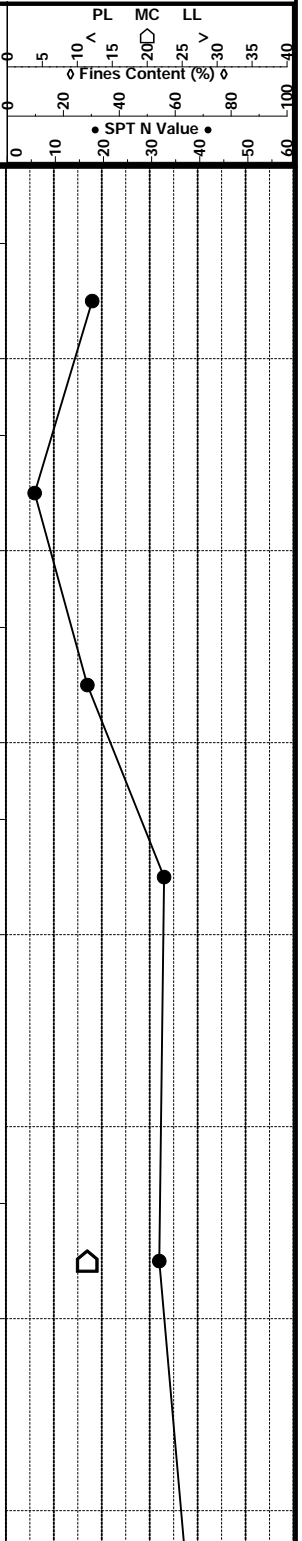

**Groundwater During Drilling: NONE** Notes:  
**Groundwater After Drilling: NONE**  
**End of Boring: 20'**



Project Number: 1198070026  
 Project Name: City of Ann Arbor  
 Misc Geotechnical Services  
 Project Location: Ann Arbor, MI  
 Client Name: City of Ann Arbor  
 Date Started: 7/31/19 Completed: 7/31/19  
 Time Started: Completed:  
 Logged By: Al Guzdial Checked By: K. Matsuda

Boring No: BAR-01  
 Longitude: Latitude:  
 Surface Elevation (ft):  
 Drilling Firm: BRAX Drilling  
 Driller Name: Al Guzdial  
 Drilling Method: HSA  
 Drill Rig Model:  
 Auger Size: 3.25"  
 Weather:

DEPTH (ft)	DESCRIPTION OF STRATA	LEGEND	SAMPLE	RECOVERY (in)	BLOW COUNTS (N VALUE)	UCS (tsf)	Soil Properties		
							PL	MC	LL
20	SILT (ML) - gray, trace gravel, hard, wet		SS-6		13-17-22 (39)	4.5 +			
End of Borehole = 20.0'. Borehole backfilled upon completion.									

**Groundwater During Drilling:** NONE **Notes:**  
**Groundwater After Drilling:** NONE  
**End of Boring:** 20'



Project Number: 1198070026  
 Project Name: City of Ann Arbor  
 Misc Geotechnical Services  
 Project Location: Ann Arbor, MI  
 Client Name: City of Ann Arbor  
 Date Started: 7/31/19 Completed: 7/31/19  
 Time Started: Completed:  
 Logged By: Al Guzdial Checked By: K. Matsuda

Boring No: BAR-02  
 Longitude: Latitude:  
 Surface Elevation (ft):  
 Drilling Firm: BRAX Drilling  
 Driller Name: Al Guzdial  
 Drilling Method: HSA  
 Drill Rig Model:  
 Auger Size: 3.25"  
 Weather:

DEPTH (ft)	DESCRIPTION OF STRATA	LEGEND	SAMPLE	RECOVERY (in)	BLOW COUNTS (N VALUE)	UCS (tsf)	PL MC LL		
							Fines Content (%)	SPT N Value	
0	6 inches of ASPHALT pavement	[Pattern]							
	4 inches of CRUSHED ASPHALT base	[Pattern]							
	SAND (SP) - brown, fine to coarse, with gravel, medium dense, moist	[Pattern]	SS-1		7-8-14 (22)				
5			SS-2		11-13-18 (31)				
	SAND (SP) - gray, fine to coarse, with gravel, dense, wet	[Pattern]	SS-3		9-13-15 (28)				
10			SS-4		19-23-17 (40)				
15	SILT (ML) - gray, with clay, trace gravel, hard, moist	[Pattern]	SS-5		11-14-15 (29)	4.5 +			

Groundwater During Drilling: NONE Notes:  
 Groundwater After Drilling: NONE  
 End of Boring: 20'



Project Number: 1198070026  
 Project Name: City of Ann Arbor  
 Misc Geotechnical Services  
 Project Location: Ann Arbor, MI  
 Client Name: City of Ann Arbor  
 Date Started: 7/31/19 Completed: 7/31/19  
 Time Started: Completed:  
 Logged By: Al Guzdial Checked By: K. Matsuda

Boring No: BAR-02  
 Longitude: Latitude:  
 Surface Elevation (ft):  
 Drilling Firm: BRAX Drilling  
 Driller Name: Al Guzdial  
 Drilling Method: HSA  
 Drill Rig Model:  
 Auger Size: 3.25"  
 Weather:

DEPTH (ft)	DESCRIPTION OF STRATA	LEGEND	SAMPLE	RECOVERY (in)	BLOW COUNTS (N VALUE)	UCS (tsf)	Soil Properties		
							PL	MC	LL
20	SILT (ML) - gray, with clay, soft, moist		SS-6		15-11-14 (25)	0.5			

End of Borehole = 20.0'. Borehole backfilled upon completion.

**Groundwater During Drilling:** NONE **Notes:**  
**Groundwater After Drilling:** NONE  
**End of Boring:** 20'





Project Number: 1198070026  
 Project Name: City of Ann Arbor  
 Misc Geotechnical Services  
 Project Location: Ann Arbor, MI  
 Client Name: City of Ann Arbor  
 Date Started: 8/1/19 Completed: 8/1/19  
 Time Started: Completed:  
 Logged By: Al Guzdial Checked By: K. Matsuda

Boring No: BAR-03  
 Longitude: Latitude:  
 Surface Elevation (ft):  
 Drilling Firm: BRAX Drilling  
 Driller Name: Al Guzdial  
 Drilling Method: HSA  
 Drill Rig Model:  
 Auger Size: 3.25"  
 Weather:

DEPTH (ft)	DESCRIPTION OF STRATA	LEGEND	SAMPLE	RECOVERY (in)	BLOW COUNTS (N VALUE)	UCS (tsf)	PL MC LL		
							Fines Content (%)		
0	5.5 inches of ASPHALT Pavement								
	4 inches of CRUSHED ASPHALT base								
	SAND (SP) - brown, fine to coarse, with gravel, medium dense to very dense, moist (wet @ 13.5')		SS-1		14-9-10 (19)				
			SS-2		7-8-22 (30)				
			SS-3		43-26-27 (53)				
			SS-4		5-7-16 (23)				
			SS-5		17-14-19 (33)	4.5 +			
	SILTY CLAY (CL) - brown, hard, moist								

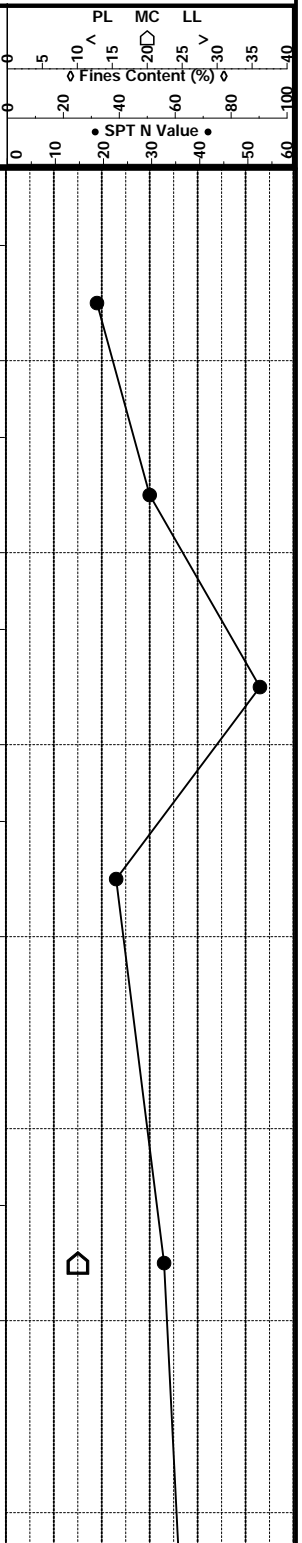

Groundwater During Drilling: 7.5' Notes:  
 Groundwater After Drilling: 4.7'  
 End of Boring: 20'



Project Number: 1198070026  
 Project Name: City of Ann Arbor  
 Misc Geotechnical Services  
 Project Location: Ann Arbor, MI  
 Client Name: City of Ann Arbor  
 Date Started: 8/1/19 Completed: 8/1/19  
 Time Started: Completed:  
 Logged By: Al Guzdial Checked By: K. Matsuda

Boring No: BAR-03  
 Longitude: Latitude:  
 Surface Elevation (ft):  
 Drilling Firm: BRAX Drilling  
 Driller Name: Al Guzdial  
 Drilling Method: HSA  
 Drill Rig Model:  
 Auger Size: 3.25"  
 Weather:

DEPTH (ft)	DESCRIPTION OF STRATA	LEGEND	SAMPLE	RECOVERY (in)	BLOW COUNTS (N VALUE)	UCS (tsf)	Soil Properties		
							PL	MC	LL
20	CLAYEY SILT (ML) - brown, hard moist		SS-6		13-17-20 (37)	4.5 +			

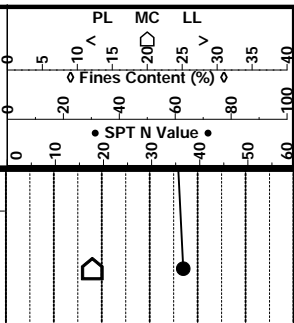

End of Borehole = 20.0'. Borehole backfilled upon completion.

**Groundwater During Drilling: 7.5'**    **Notes:**  
**Groundwater After Drilling: 4.7'**  
**End of Boring: 20'**



Project Number: 1198070026  
 Project Name: City of Ann Arbor  
 Misc Geotechnical Services  
 Project Location: Ann Arbor, MI  
 Client Name: City of Ann Arbor  
 Date Started: 7/31/19 Completed: 7/31/19  
 Time Started: Completed:  
 Logged By: Al Guzdial Checked By: K. Matsuda

Boring No: BAR-04  
 Longitude: Latitude:  
 Surface Elevation (ft):  
 Drilling Firm: BRAX Drilling  
 Driller Name: Al Guzdial  
 Drilling Method: HSA  
 Drill Rig Model:  
 Auger Size: 3.25"  
 Weather:

DEPTH (ft)	DESCRIPTION OF STRATA	LEGEND	SAMPLE	RECOVERY (in)	BLOW COUNTS (N VALUE)	UCS (tsf)	PL MC LL		
							Fines Content (%)	SPT N Value	
0	6 inches of ASPHALT pavement								
	6 inches of SAND and GRAVEL base								
	SAND (SP) - brown, fine to coarse, with gravel, trace clay, dense, wet		SS-1		13-14-17 (31)				
5			SS-2		27-50/3"- (50+)				
	SAND (SP) - brown, fine to coarse, with gravel, medium dense, wet		SS-3		9-14-15 (29)				
10			SS-4		7-9-12 (21)				
15	SILTY CLAY (CL) - brown, some sand and gravel, hard, moist		SS-5		11-17-18 (35)	4.5 +			

Groundwater During Drilling: 1'  
 Groundwater After Drilling: 7.5'  
 End of Boring: 20'

Notes:



Project Number: 1198070026  
 Project Name: City of Ann Arbor  
 Misc Geotechnical Services  
 Project Location: Ann Arbor, MI  
 Client Name: City of Ann Arbor  
 Date Started: 7/31/19 Completed: 7/31/19  
 Time Started: Completed:  
 Logged By: Al Guzdial Checked By: K. Matsuda

Boring No: BAR-04  
 Longitude: Latitude:  
 Surface Elevation (ft):  
 Drilling Firm: BRAX Drilling  
 Driller Name: Al Guzdial  
 Drilling Method: HSA  
 Drill Rig Model:  
 Auger Size: 3.25"  
 Weather:

DEPTH (ft)	DESCRIPTION OF STRATA	LEGEND	SAMPLE	RECOVERY (in)	BLOW COUNTS (N VALUE)	UCS (tsf)	PL MC LL Fines Content (%) SPT N Value
20			SS-6		9-13-17 (30)		

End of Borehole = 20.0'. Borehole backfilled upon completion.

Groundwater During Drilling: 1'  
 Groundwater After Drilling: 7.5'  
 End of Boring: 20'

Notes:



Project Number: 1198070026  
 Project Name: City of Ann Arbor  
 Misc Geotechnical Services  
 Project Location: Ann Arbor, MI  
 Client Name: City of Ann Arbor  
 Date Started: 7/31/19 Completed: 7/31/19  
 Time Started: Completed:  
 Logged By: Al Guzdial Checked By: K. Matsuda

Boring No: BAR-05  
 Longitude: Latitude:  
 Surface Elevation (ft):  
 Drilling Firm: BRAX Drilling  
 Driller Name: Al Guzdial  
 Drilling Method: HSA  
 Drill Rig Model:  
 Auger Size: 3.25"  
 Weather:

DEPTH (ft)	DESCRIPTION OF STRATA	LEGEND	SAMPLE	RECOVERY (in)	BLOW COUNTS (N VALUE)	UCS (tsf)	PL MC LL		
							Fines Content (%)	SPT N Value	
0	5" Asphalt.								
	Sand (SP) - brown, fine to coarse, with gravel, travel clay and silt, medium dense, dry.		SS-1		5-7-12 (19)				
			SS-2		4-9-11 (20)				
5			SS-3		3-4-5 (9)	0.5			
	Clay (CL) - gray, some sand and silt, trace gravel, soft, moist.		SS-4		5-7-7 (14)	0.5			
10			SS-5		11-9-13 (22)				
	Silty clay (CL) - gray, trace sand, soft, moist.								
	Silty sand (SP) - gray, fine, medium dense, moist.								
15									

**Groundwater During Drilling:** NONE **Notes:** Offset to north side of road due to utilities and to east due  
**Groundwater After Drilling:** NONE to power lines.  
**End of Boring:** 20'



Project Number: 1198070026  
 Project Name: City of Ann Arbor  
 Misc Geotechnical Services  
 Project Location: Ann Arbor, MI  
 Client Name: City of Ann Arbor  
 Date Started: 7/31/19 Completed: 7/31/19  
 Time Started: Completed:  
 Logged By: Al Guzdial Checked By: K. Matsuda

Boring No: BAR-05  
 Longitude: Latitude:  
 Surface Elevation (ft):  
 Drilling Firm: BRAX Drilling  
 Driller Name: Al Guzdial  
 Drilling Method: HSA  
 Drill Rig Model:  
 Auger Size: 3.25"  
 Weather:

DEPTH (ft)	DESCRIPTION OF STRATA	LEGEND	SAMPLE	RECOVERY (in)	BLOW COUNTS (N VALUE)	UCS (tsf)	PL MC LL Fines Content (%) SPT N Value
20	Silt (ML) - gray, some sand and clay, medium stiff, moist.		SS-6		12-14-15 (29)	1	

End of Borehole = 20.0'. Borehole backfilled upon completion.

**Groundwater During Drilling:** NONE **Notes:** Offset to north side of road due to utilities and to east due  
**Groundwater After Drilling:** NONE to power lines.  
**End of Boring:** 20'



Project Number: 1198070026  
 Project Name: City of Ann Arbor  
 Misc Geotechnical Services  
 Project Location: Ann Arbor, MI  
 Client Name: City of Ann Arbor  
 Date Started: 7/31/19 Completed: 7/31/19  
 Time Started: Completed:  
 Logged By: Al Guzdial Checked By: K. Matsuda

Boring No: BAR-06  
 Longitude: Latitude:  
 Surface Elevation (ft):  
 Drilling Firm: BRAX Drilling  
 Driller Name: Al Guzdial  
 Drilling Method: HSA  
 Drill Rig Model:  
 Auger Size: 3.25"  
 Weather:

DEPTH (ft)	DESCRIPTION OF STRATA	LEGEND	SAMPLE	RECOVERY (in)	BLOW COUNTS (N VALUE)	UCS (tsf)	PL MC LL		
							Fines Content (%)	SPT N Value	
0	5" Asphalt.								
	Block of broken-up asphalt.								
	Sand (SP) - brown, fine to coarse, some gravel and silt, medium dense, moist.		SS-1		11-13-14 (27)				
	Clay (CL) - brown, some sand and gravel, medium stiff, moist.		SS-2		4-6-5 (11)	1			
	Clay (CL) - brown, some sand and gravel, soft, moist.		SS-3		3-3-3 (6)	0.5			
			SS-4		4-8-5 (13)	0.5			
	Silty sand (SP) - gray, fine, dense, moist.		SS-5		8-10-28 (38)				

Groundwater During Drilling: NONE Notes:  
 Groundwater After Drilling: 13'  
 End of Boring: 20'



Project Number: 1198070026  
 Project Name: City of Ann Arbor  
 Misc Geotechnical Services  
 Project Location: Ann Arbor, MI  
 Client Name: City of Ann Arbor  
 Date Started: 7/31/19 Completed: 7/31/19  
 Time Started: Completed:  
 Logged By: Al Guzdial Checked By: K. Matsuda

Boring No: BAR-06  
 Longitude: Latitude:  
 Surface Elevation (ft):  
 Drilling Firm: BRAX Drilling  
 Driller Name: Al Guzdial  
 Drilling Method: HSA  
 Drill Rig Model:  
 Auger Size: 3.25"  
 Weather:

DEPTH (ft)	DESCRIPTION OF STRATA	LEGEND	SAMPLE	RECOVERY (in)	BLOW COUNTS (N VALUE)	UCS (tsf)	PL MC LL Fines Content (%) SPT N Value
20	Silty clay (CL) - gray, trace sand and gravel, hard, moist.		SS-6		10-12-14 (26)	4.5 +	

End of Borehole = 20.0'. Borehole backfilled upon completion.

**Groundwater During Drilling:** NONE **Notes:**  
**Groundwater After Drilling:** 13'  
**End of Boring:** 20'





Project Number: 1198070026  
 Project Name: City of Ann Arbor  
 Misc Geotechnical Services  
 Project Location: Ann Arbor, MI  
 Client Name: City of Ann Arbor  
 Date Started: 7/30/19 Completed: 7/30/19  
 Time Started: Completed:  
 Logged By: Al Guzdial Checked By: K. Matsuda

Boring No: BAR-07  
 Longitude: Latitude:  
 Surface Elevation (ft):  
 Drilling Firm: BRAX Drilling  
 Driller Name: Al Guzdial  
 Drilling Method: HSA  
 Drill Rig Model:  
 Auger Size: 3.25"  
 Weather:

DEPTH (ft)	DESCRIPTION OF STRATA	LEGEND	SAMPLE	RECOVERY (in)	BLOW COUNTS (N VALUE)	UCS (tsf)	Soil Properties		
							PL	MC	LL
0	4" Asphalt.								
	Sand (SP) - gray, fine to coarse, with gravel, medium dense, moist.		SS-1		9-7-4 (11)				
			SS-2		5-6-5 (11)				
5	Sand (SP) - gray, fine to coarse, some gravel, medium dense, moist. End of Borehole = 5.0'. Borehole backfilled upon completion.								

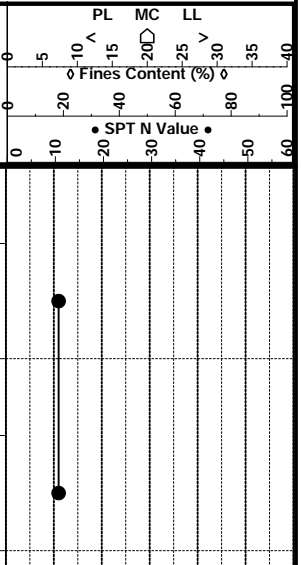

**Groundwater During Drilling:** NONE **Notes:** Offset to west side of Bridge.  
**Groundwater After Drilling:** NONE  
**End of Boring:** 5'



Project Number: 1198070026  
 Project Name: City of Ann Arbor  
 Misc Geotechnical Services  
 Project Location: Ann Arbor, MI  
 Client Name: City of Ann Arbor  
 Date Started: 7/30/19 Completed: 7/30/19  
 Time Started: Completed:  
 Logged By: Al Guzdial Checked By: K. Matsuda

Boring No: BAR-08  
 Longitude: Latitude:  
 Surface Elevation (ft):  
 Drilling Firm: BRAX Drilling  
 Driller Name: Al Guzdial  
 Drilling Method: HSA  
 Drill Rig Model:  
 Auger Size: 3.25"  
 Weather:

DEPTH (ft)	DESCRIPTION OF STRATA	LEGEND	SAMPLE	RECOVERY (in)	BLOW COUNTS (N VALUE)	UCS (tsf)	Soil Properties		
							PL	MC	LL
0	4.5" Asphalt.								
	Fill.								
	Fill Sand (SP) - brown, fine to coarse, trace clay and silt, loose, moist.		SS-1		6-5-4 (9)				
	Sand (SP) - gray, fine to coarse, with gravel, some clay and silt, medium dense, moist.		SS-2		6-4-10 (14)				
5	End of Borehole = 5.0'. Borehole backfilled upon completion.								

**Groundwater During Drilling:** NONE **Notes:** Offset 10' west due to utilities.  
**Groundwater After Drilling:** NONE  
**End of Boring:** 5'



Project Number: 1198070026  
 Project Name: City of Ann Arbor  
 Misc Geotechnical Services  
 Project Location: Ann Arbor, MI  
 Client Name: City of Ann Arbor  
 Date Started: 7/30/19 Completed: 7/30/19  
 Time Started: Completed:  
 Logged By: Al Guzdial Checked By: K. Matsuda

Boring No: BAR-09  
 Longitude: Latitude:  
 Surface Elevation (ft):  
 Drilling Firm: BRAX Drilling  
 Driller Name: Al Guzdial  
 Drilling Method: HSA  
 Drill Rig Model:  
 Auger Size: 3.25"  
 Weather:

DEPTH (ft)	DESCRIPTION OF STRATA	LEGEND	SAMPLE	RECOVERY (in)	BLOW COUNTS (N VALUE)	UCS (tsf)	Soil Properties		
							PL	MC	LL
0	4.5" Asphalt.								
	Fill.								
	Sandy clay (CL) - brown, some gravel, trace organics, medium stiff, moist.		SS-1		'13-14-5 (19)	1			
	Sandy clay (CL) - brown, trace gravel, soft, moist.		SS-2		5-6-5 (11)	0.5			
5	End of Borehole = 5.0'. Borehole backfilled upon completion.								

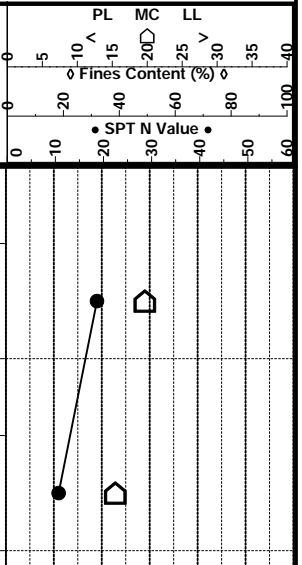

**Groundwater During Drilling:** NONE **Notes:**  
**Groundwater After Drilling:** NONE  
**End of Boring:** 5'



Project Number: 1198070026  
 Project Name: City of Ann Arbor  
 Misc Geotechnical Services  
 Project Location: Ann Arbor, MI  
 Client Name: City of Ann Arbor  
 Date Started: 7/30/19 Completed: 7/30/19  
 Time Started: Completed:  
 Logged By: Al Guzdial Checked By: K. Matsuda

Boring No: BAR-10  
 Longitude: Latitude:  
 Surface Elevation (ft):  
 Drilling Firm: BRAX Drilling  
 Driller Name: Al Guzdial  
 Drilling Method: HSA  
 Drill Rig Model:  
 Auger Size: 3.25"  
 Weather:

DEPTH (ft)	DESCRIPTION OF STRATA	LEGEND	SAMPLE	RECOVERY (in)	BLOW COUNTS (N VALUE)	UCS (tsf)	Soil Properties		
							PL	MC	LL
0	5" Asphalt.								
	4" Fill.								
	Clay (CL) - brown, with sand, trace gravel, medium stiff, moist.		SS-1		7-4-5 (9)	1			
	Clay (CL) - brown, with sand, trace gravel, soft, moist.		SS-2		3-3-4 (7)	0.5			
5	End of Borehole = 5.0'. Borehole backfilled upon completion.								

Groundwater During Drilling: NONE Notes:  
 Groundwater After Drilling: NONE  
 End of Boring: 5'



TYPE OF CASTING	NEEHAH FOUNDRY	EAST JORDAN IRON WORKS
BARRIER CURB INLET	R-3013B, TYPES GRATE (500 POUNDS)	7045, TYPE M1 GRATE (490 POUNDS)
BARRIER CURB DOUBLE INLET	R- 3249F, TYPE S GRATE (410 POUNDS)	N/A
MOUNTABLE CURB INLET	R-3034B, TYPE S GRATE (500 POUNDS)	7065, TYPE M1 GRATE (470 POUNDS)
GUTTER INLET	R-3448C, TYPE S GRATE (285 POUNDS)	5080, TYPE M2 GRATE (490 POUNDS)
GUTTER DOUBLE INLET	R-3448B, TYPE S GRATE (265 POUNDS)	5000, TYPE M2 GRATE (490 POUNDS)
YARD DRAIN	R-2560-E1 (285 POUNDS)	1040, TYPE O2 GRATE (355 POUNDS)
YARD DRAIN IN CITY PARK	N/A	1040, TYPE M1 GRATE (400 POUNDS)
*MANHOLE FRAME & COVER (WATER & STORM)		1040, TYPE A COVER (400 POUNDS)
**WATERTIGHT MANHOLE FRAME & COVER (SANITARY)		1040, TYPE AGS COVER (400 POUNDS)
MONUMENT BOX	N/A	8360 (100 POUNDS)

**NOTES:**

\*FRAMES AND COVERS MUST HAVE MACHINED BEARING SURFACES.

\*\*MANHOLE COVERS SHALL BE LABELED WITH "CITY OF ANN ARBOR" AND "WATER", "STORM" OR "SANITARY", WHICHEVER IS APPLICABLE. ALL COVERS SHALL INCLUDE THE CITY'S CUSTOM LOGO IN USE AT THE TIME OF THE PROJECT.

\*\*\*SANITARY MANHOLE COVERS SHALL BE 1040AGS WITH A 1/4" NEOPRENE GASKET TO SEAL AGAINST THE FRAME.

## STANDARD CASTING SCHEDULE SD-GU-5

REVISED  
1-24-19



**CITY OF ANN ARBOR  
PUBLIC SERVICE**  
301 EAST HURON STREET  
P.O. BOX 8647  
ANN ARBOR, MI 48107-8647  
734-794-6410  
www.a2gov.org

REV. NO.	DATE	DRAWN BY	CHECKED BY
<b>STANDARD CASTING SCHEDULE</b>			
DR. ARG	CH. CEC	DRAWING NO.	
SCALE N.T.S.	DATE 1/24/19	<b>SD-GU-5</b>	

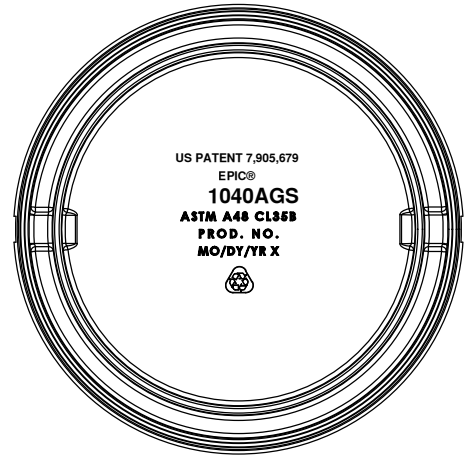
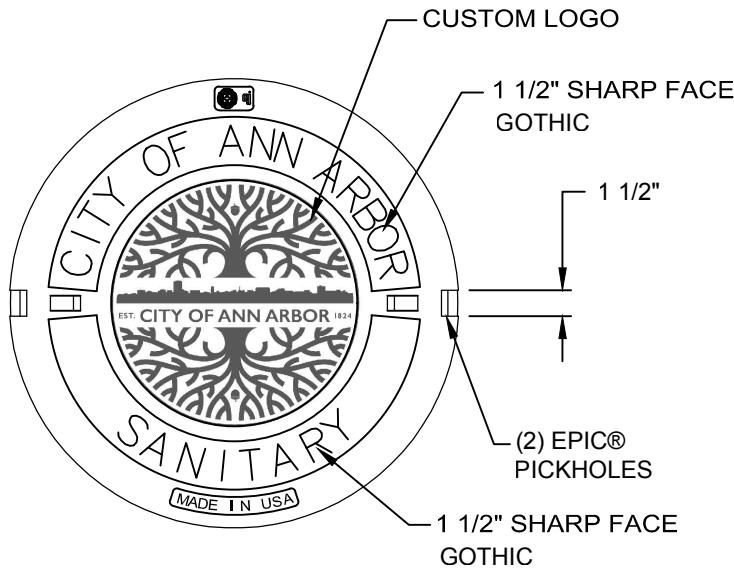

BOTTOM VIEW

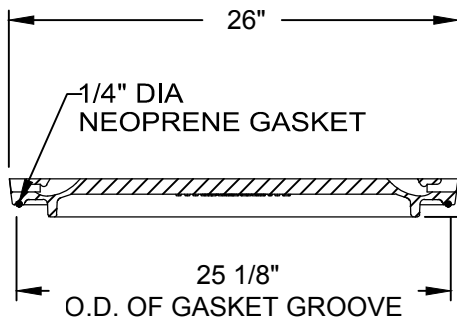

SECTION

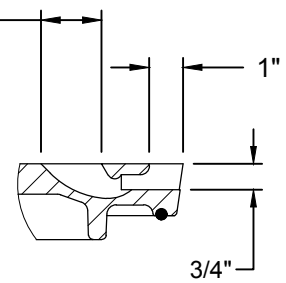
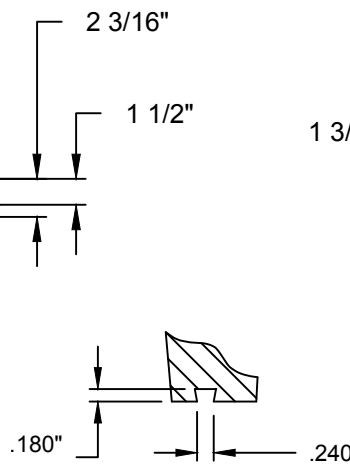

EPIC ® DETAIL

**REVISED**  
1-24-19

EJ PRODUCT #001040326



**CITY OF ANN ARBOR  
PUBLIC SERVICES**  
301 EAST HURON STREET  
P.O. BOX 8647  
ANN ARBOR, MI 48107-8647  
734-794-6410  
www.a2gov.org

REV. NO.	DATE	DRAWN BY	CHECKED BY
<b>SANITARY MANHOLE COVER 1040A</b>			
DR. ARG	CH. CEC	DRAWING NO.	
SCALE N.T.S.	DATE 1/24/19	<b>SAN-MH</b>	

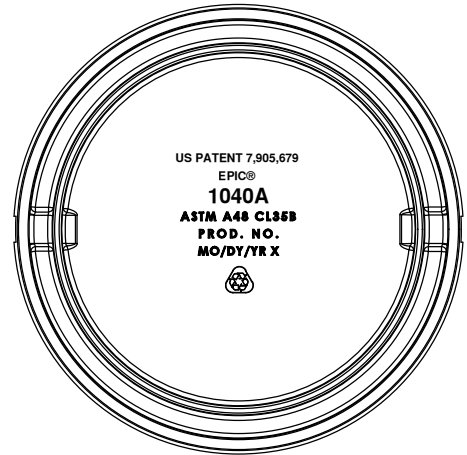
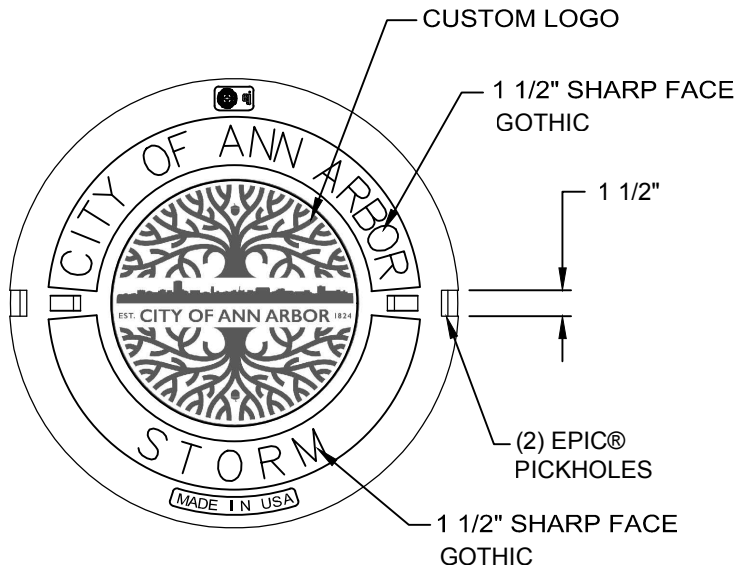

BOTTOM VIEW

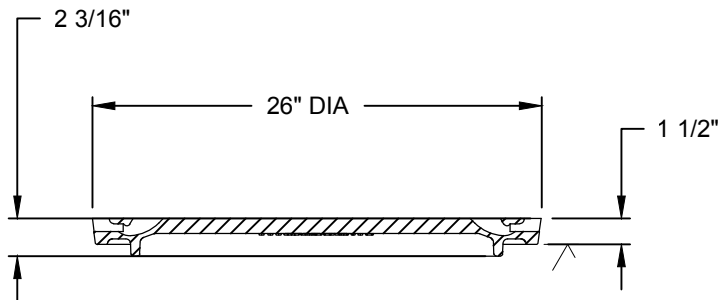

SECTION

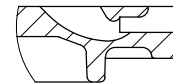

EPIC® DETAIL

**REVISED**  
1-24-19

EJ PRODUCT #001040325



**CITY OF ANN ARBOR  
PUBLIC SERVICES**  
301 EAST HURON STREET  
P.O. BOX 8647  
ANN ARBOR, MI 48107-8647  
734-794-6410  
www.a2gov.org

REV. NO.	DATE	DRAWN BY	CHECKED BY
<b>STORM MANHOLE COVER 1040A</b>			
DR. ARG	CH. CEC	DRAWING NO.	
SCALE N.T.S.	DATE 1/24/19	<b>STM-MH</b>	



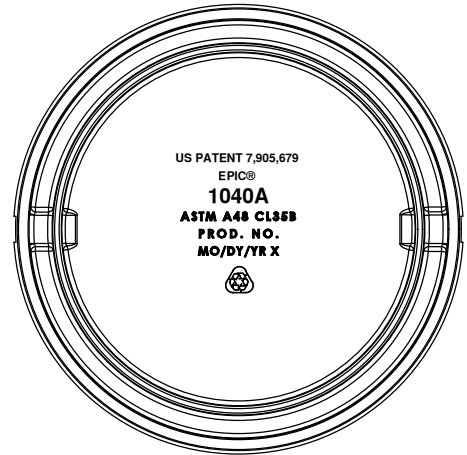
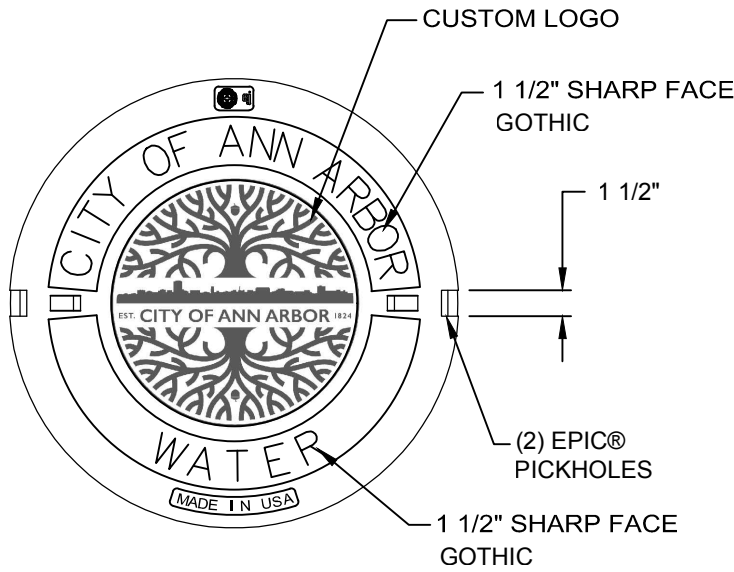

BOTTOM VIEW

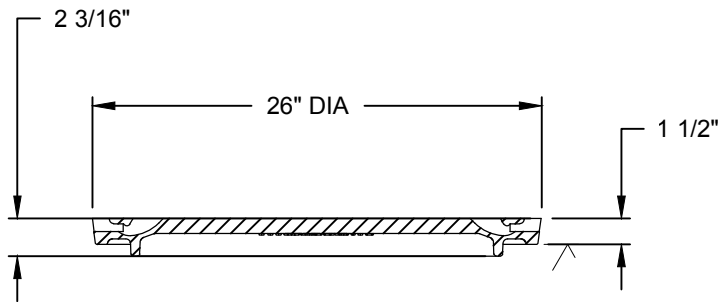

SECTION

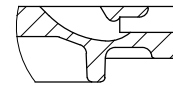

EPIC® DETAIL

**REVISED**  
1-24-19

EJ PRODUCT #001040324



**CITY OF ANN ARBOR  
PUBLIC SERVICES**  
301 EAST HURON STREET  
P.O. BOX 8647  
ANN ARBOR, MI 48107-8647  
734-794-6410  
www.a2gov.org

REV. NO.	DATE	DRAWN BY	CHECKED BY
<b>WATER MANHOLE COVER 1040A</b>			
DR. ARG	CH. CEC	DRAWING NO.	
SCALE N.T.S.	DATE 1/24/19	<b>W-MH</b>	



**CITY OF ANN ARBOR**  
**LIVING WAGE ORDINANCE DECLARATION OF COMPLIANCE**

The Ann Arbor Living Wage Ordinance (Section 1:811-1:821 of Chapter 23 of Title I of the Code) requires that an employer who is (a) a contractor providing services to or for the City for a value greater than \$10,000 for any twelve-month contract term, or (b) a recipient of federal, state, or local grant funding administered by the City for a value greater than \$10,000, or (c) a recipient of financial assistance awarded by the City for a value greater than \$10,000, shall pay its employees a prescribed minimum level of compensation (i.e., Living Wage) for the time those employees perform work on the contract or in connection with the grant or financial assistance. The Living Wage must be paid to these employees for the length of the contract/program.

*Companies employing fewer than 5 persons and non-profits employing fewer than 10 persons are exempt from compliance with the Living Wage Ordinance. If this exemption applies to your company/non-profit agency please check here  No. of employees\_\_*

The Contractor or Grantee agrees:

- (a) To pay each of its employees whose wage level is not required to comply with federal, state or local prevailing wage law, for work covered or funded by a contract with or grant from the City, no less than the Living Wage. The current Living Wage is defined as \$13.61/hour for those employers that provide employee health care (as defined in the Ordinance at Section 1:815 Sec. 1 (a)), or no less than \$15.18/hour for those employers that do not provide health care. The Contractor or Grantor understands that the Living Wage is adjusted and established annually on April 30 in accordance with the Ordinance and covered employers shall be required to pay the adjusted amount thereafter to be in compliance with Section 1:815(3).

**Check the applicable box below which applies to your workforce**

Employees who are assigned to any covered City contract/grant will be paid at or above the applicable living wage without health benefits

Employees who are assigned to any covered City contract/grant will be paid at or above the applicable living wage with health benefits

- (b) To post a notice approved by the City regarding the applicability of the Living Wage Ordinance in every work place or other location in which employees or other persons contracting for employment are working.
- (c) To provide to the City payroll records or other documentation within ten (10) business days from the receipt of a request by the City.
- (d) To permit access to work sites to City representatives for the purposes of monitoring compliance, and investigating complaints or non-compliance.
- (e) To take no action that would reduce the compensation, wages, fringe benefits, or leave available to any employee covered by the Living Wage Ordinance or any person contracted for employment and covered by the Living Wage Ordinance in order to pay the living wage required by the Living Wage Ordinance.

The undersigned states that he/she has the requisite authority to act on behalf of his/her employer in these matters and has offered to provide the services or agrees to accept financial assistance in accordance with the terms of the Living Wage Ordinance. The undersigned certifies that he/she has read and is familiar with the terms of the Living Wage Ordinance, obligates the Employer/Grantee to those terms and acknowledges that if his/her employer is found to be in violation of Ordinance it may be subject to civil penalties and termination of the awarded contract or grant of financial assistance.

\_\_\_\_\_  
Company Name

\_\_\_\_\_  
Street Address

\_\_\_\_\_  
Signature of Authorized Representative

\_\_\_\_\_  
Date

\_\_\_\_\_  
City, State, Zip

\_\_\_\_\_  
Print Name and Title

\_\_\_\_\_  
Phone/Email address

# CITY OF ANN ARBOR LIVING WAGE ORDINANCE

**RATE EFFECTIVE APRIL 30, 2019 - ENDING APRIL 29, 2020**

**\$13.61** per hour

If the employer provides health care benefits\*

**\$15.18** per hour

If the employer does **NOT** provide health care benefits\*

Employers providing services to or for the City of Ann Arbor or recipients of grants or financial assistance from the City of Ann Arbor for a value of more than \$10,000 in a twelve-month period of time must pay those employees performing work on a City of Ann Arbor contract or grant, the above living wage.

## **ENFORCEMENT**

The City of Ann Arbor may recover back wages either administratively or through court action for the employees that have been underpaid in violation of the law. Persons denied payment of the living wage have the right to bring a civil action for damages in addition to any action taken by the City.

Violation of this Ordinance is punishable by fines of not more than \$500/violation plus costs, with each day being considered a separate violation. Additionally, the City of Ann Arbor has the right to modify, terminate, cancel or suspend a contract in the event of a violation of the Ordinance.

\* Health Care benefits include those paid for by the employer or making an employer contribution toward the purchase of health care. The employee contribution must not exceed \$.50 an hour for an average work week; and the employer cost or contribution must equal no less than \$1/hr for the average work week.

**The Law Requires Employers to Display This Poster Where Employees Can Readily See It.**

**For Additional Information or to File a Complaint contact  
Colin Spencer at 734/794-6500 or [cspencer@a2gov.org](mailto:cspencer@a2gov.org)**



<b>Vendor Conflict of Interest Disclosure Form</b>
--

All vendors interested in conducting business with the City of Ann Arbor must complete and return the Vendor Conflict of Interest Disclosure Form in order to be eligible to be awarded a contract. Please note that all vendors are subject to comply with the City of Ann Arbor’s conflict of interest policies as stated within the certification section below.

If a vendor has a relationship with a City of Ann Arbor official or employee, an immediate family member of a City of Ann Arbor official or employee, the vendor shall disclose the information required below.

1. No City official or employee or City employee’s immediate family member has an ownership interest in vendor’s company or is deriving personal financial gain from this contract.
2. No retired or separated City official or employee who has been retired or separated from the City for less than one (1) year has an ownership interest in vendor’s Company.
3. No City employee is contemporaneously employed or prospectively to be employed with the vendor.
4. Vendor hereby declares it has not and will not provide gifts or hospitality of any dollar value or any other gratuities to any City employee or elected official to obtain or maintain a contract.
5. Please note any exceptions below:

<b>Conflict of Interest Disclosure*</b>	
Name of City of Ann Arbor employees, elected officials or immediate family members with whom there may be a potential conflict of interest.	<input type="checkbox"/> Relationship to employee <hr style="border: 0; border-top: 1px solid black;"/> <input type="checkbox"/> Interest in vendor’s company <input type="checkbox"/> Other (please describe in box below)

\*Disclosing a potential conflict of interest does not disqualify vendors. In the event vendors do not disclose potential conflicts of interest and they are detected by the City, vendor will be exempt from doing business with the City.

<b>I certify that this Conflict of Interest Disclosure has been examined by me and that its contents are true and correct to my knowledge and belief and I have the authority to so certify on behalf of the Vendor by my signature below:</b>		
<b>Vendor Name</b>	<b>Vendor Phone Number</b>	
<b>Signature of Vendor Authorized Representative</b>	<b>Date</b>	<b>Printed Name of Vendor Authorized Representative</b>

Questions about this form? Contact Procurement Office City of Ann Arbor Phone: 734/794-6500, procurement@a2gov.org



# CITY OF ANN ARBOR NON-DISCRIMINATION ORDINANCE

Relevant provisions of Chapter 112, Nondiscrimination, of the Ann Arbor City Code are included below.  
You can review the entire ordinance at [www.a2gov.org/humanrights](http://www.a2gov.org/humanrights).

**Intent:** It is the intent of the city that no individual be denied equal protection of the laws; nor shall any individual be denied the enjoyment of his or her civil or political rights or be discriminated against because of actual or perceived age, arrest record, color, disability, educational association, familial status, family responsibilities, gender expression, gender identity, genetic information, height, HIV status, marital status, national origin, political beliefs, race, religion, sex, sexual orientation, source of income, veteran status, victim of domestic violence or stalking, or weight.

**Discriminatory Employment Practices:** No person shall discriminate in the hire, employment, compensation, work classifications, conditions or terms, promotion or demotion, or termination of employment of any individual. No person shall discriminate in limiting membership, conditions of membership or termination of membership in any labor union or apprenticeship program.

**Discriminatory Effects:** No person shall adopt, enforce or employ any policy or requirement which has the effect of creating unequal opportunities according to actual or perceived age, arrest record, color, disability, educational association, familial status, family responsibilities, gender expression, gender identity, genetic information, height, HIV status, marital status, national origin, political beliefs, race, religion, sex, sexual orientation, source of income, veteran status, victim of domestic violence or stalking, or weight for an individual to obtain housing, employment or public accommodation, except for a bona fide business necessity. Such a necessity does not arise due to a mere inconvenience or because of suspected objection to such a person by neighbors, customers or other persons.

**Nondiscrimination by City Contractors:** All contractors proposing to do business with the City of Ann Arbor shall satisfy the contract compliance administrative policy adopted by the City Administrator in accordance with the guidelines of this section. All city contractors shall ensure that applicants are employed and that employees are treated during employment in a manner which provides equal employment opportunity and tends to eliminate inequality based upon any classification protected by this chapter. All contractors shall agree not to discriminate against an employee or applicant for employment with respect to hire, tenure, terms, conditions, or privileges of employment, or a matter directly or indirectly related to employment, because of any applicable protected classification. All contractors shall be required to post a copy of Ann Arbor's Non-Discrimination Ordinance at all work locations where its employees provide services under a contract with the city.

**Complaint Procedure:** If any individual believes there has been a violation of this chapter, he/she may file a complaint with the City's Human Rights Commission. The complaint must be filed within 180 calendar days from the date of the individual's knowledge of the allegedly discriminatory action or 180 calendar days from the date when the individual should have known of the allegedly discriminatory action. A complaint that is not filed within this timeframe cannot be considered by the Human Rights Commission. To file a complaint, first complete the complaint form, which is available at [www.a2gov.org/humanrights](http://www.a2gov.org/humanrights). Then submit it to the Human Rights Commission by e-mail ([hrc@a2gov.org](mailto:hrc@a2gov.org)), by mail (Ann Arbor Human Rights Commission, PO Box 8647, Ann Arbor, MI 48107), or in person (City Clerk's Office). For further information, please call the commission at 734-794-6141 or e-mail the commission at [hrc@a2gov.org](mailto:hrc@a2gov.org).

**Private Actions For Damages or Injunctive Relief:** To the extent allowed by law, an individual who is the victim of discriminatory action in violation of this chapter may bring a civil action for appropriate injunctive relief or damages or both against the person(s) who acted in violation of this chapter.

THIS IS AN OFFICIAL GOVERNMENT NOTICE AND  
MUST BE DISPLAYED WHERE EMPLOYEES CAN READILY SEE IT.

## MICHIGAN DEPARTMENT OF TRANSPORTATION CERTIFIED PAYROLL

COMPLETION OF CERTIFIED PAYROLL FORM FULFILLS THE MINIMUM MDOT PREVAILING WAGE REQUIREMENTS

(1) NAME OF CONTRACTOR / SUBCONTRACTOR (CIRCLE ONE) (2) ADDRESS

(3) PAYROLL NO. (4) FOR WEEK ENDING (5) PROJECT AND LOCATION (6) CONTRACT ID

(a)	(b)	(c)	(d) DAY AND DATE							(e)	(f)	(g)	(h)	(i)	(j) DEDUCTIONS						(k)		
			HOURS WORKED ON PROJECT												TOTAL HOURS ON PROJECT	PROJECT RATE OF PAY	PROJECT RATE OF FRINGE PAY	GROSS PROJECT EARNED	GROSS WEEKLY EARNED	TOTAL WEEKLY HOURS WORKED ALL JOBS		FICA	FEDERAL
EMPLOYEE INFORMATION	WORK CLASSIFICATION	Hour Type								0			\$0.00									\$0.00	\$0.00
NAME:										0			\$0.00									\$0.00	\$0.00
ETH#GEN: ID #:	GROUP/CLASS #:	S								0			\$0.00									\$0.00	\$0.00
NAME:										0			\$0.00									\$0.00	\$0.00
ETH#GEN: ID #:	GROUP/CLASS #:	S								0			\$0.00									\$0.00	\$0.00
NAME:										0			\$0.00									\$0.00	\$0.00
ETH#GEN: ID #:	GROUP/CLASS #:	S								0			\$0.00									\$0.00	\$0.00
NAME:										0			\$0.00									\$0.00	\$0.00
ETH#GEN: ID #:	GROUP/CLASS #:	S								0			\$0.00									\$0.00	\$0.00
NAME:										0			\$0.00									\$0.00	\$0.00
ETH#GEN: ID #:	GROUP/CLASS #:	S								0			\$0.00									\$0.00	\$0.00
NAME:										0			\$0.00									\$0.00	\$0.00
ETH#GEN: ID #:	GROUP/CLASS #:	S								0			\$0.00									\$0.00	\$0.00
NAME:										0			\$0.00									\$0.00	\$0.00



Date \_\_\_\_\_

I, \_\_\_\_\_  
 (Name of Signatory Party) (Title)

do hereby state:

(1) That I pay or supervise the payment of the persons employed by

\_\_\_\_\_ on the  
 (Contractor or Subcontractor)  
 \_\_\_\_\_; that during the payroll period commencing on the  
 (Building or Work)  
 \_\_\_\_\_ day of \_\_\_\_\_, \_\_\_\_\_, and ending the \_\_\_\_\_ day of \_\_\_\_\_, \_\_\_\_\_,  
 all persons employed on said project have been paid the full weekly wages earned, that no rebates have  
 been or will be made either directly or indirectly to or on behalf of said

\_\_\_\_\_ from the full  
 (Contractor or Subcontractor)

weekly wages earned by any person and that no deductions have been made either directly or indirectly  
 from the full wages earned by any person, other than permissible deductions as defined in Regulations, Part  
 3 (29 C.F.R. Subtitle A), issued by the Secretary of Labor under the Copeland Act, as amended (48 Stat. 948,  
 63 Stat. 108, 72 Stat. 967; 76 Stat. 357; 40 U.S.C. § 3145), and described below:

\_\_\_\_\_  
 \_\_\_\_\_  
 \_\_\_\_\_  
 \_\_\_\_\_

(2) That any payrolls otherwise under this contract required to be submitted for the above period are  
 correct and complete; that the wage rates for laborers or mechanics contained therein are not less than the  
 applicable wage rates contained in any wage determination incorporated into the contract; that the  
 classifications set forth therein for each laborer or mechanic conform with the work he performed.

(3) That any apprentices employed in the above period are duly registered in a bona fide  
 apprenticeship program registered with a State apprenticeship agency recognized by the Bureau of  
 Apprenticeship and Training, United States Department of Labor, or if no such recognized agency exists in a  
 State, are registered with the Bureau of Apprenticeship and Training, United States Department of Labor.

(4) That:

(a) WHERE FRINGE BENEFITS ARE PAID TO APPROVED PLANS, FUNDS, OR PROGRAMS

- in addition to the basic hourly wage rates paid to each laborer or mechanic listed in  
 the above referenced payroll, payments of fringe benefits as listed in the contract  
 have been or will be made to appropriate programs for the benefit of such  
 employees, except as noted in section 4(c) below.

(b) WHERE FRINGE BENEFITS ARE PAID IN CASH

- Each laborer or mechanic listed in the above referenced payroll has been paid,  
 as indicated on the payroll, an amount not less than the sum of the applicable  
 basic hourly wage rate plus the amount of the required fringe benefits as listed  
 in the contract, except as noted in section 4(c) below.

(c) EXCEPTIONS

EXCEPTION (CRAFT)	EXPLANATION

REMARKS:  
 \_\_\_\_\_  
 \_\_\_\_\_  
 \_\_\_\_\_  
 \_\_\_\_\_  
 \_\_\_\_\_  
 \_\_\_\_\_  
 \_\_\_\_\_  
 \_\_\_\_\_  
 \_\_\_\_\_  
 \_\_\_\_\_

NAME AND TITLE	SIGNATURE

THE WILLFUL FALSIFICATION OF ANY OF THE ABOVE STATEMENTS MAY SUBJECT THE CONTRACTOR OR  
 SUBCONTRACTOR TO CIVIL OR CRIMINAL PROSECUTION. SEE SECTION 1001 OF TITLE 18 AND SECTION 231 OF TITLE  
 31 OF THE UNITED STATES CODE.