



CITY OF ANN ARBOR, MICHIGAN

Planning & Development Services

INFORMATION SHEET 11

Issued February 26, 2007

DRAWING REQUIREMENTS

ONE AND TWO FAMILY HOMES

NEW HOMES OR ADDITION / REMODELING OF EXISTING

This Information Sheet serves as a guideline to help customers understand the required drawings that must be submitted to obtain a residential building permit. It contains an example of the drawings required along with a checklist of the information that should be included on each drawing.

Drawings should be no larger than 24 inches by 36 inches, and no smaller than 8 ½ inches by 11 inches. All pages should be the same size. No original pen or pencil drawings and reproductions on substantial paper are required—no tracing paper.

Drawings should be competently drawn, clear with legible writing. An architect is not required but drawings should be clear as to what work is being done. Hand drawn rough sketches are not acceptable.

Submit two sets of drawings.

Drawings must be stapled into sets, in order with each page numbered consecutively.

Please note that one-and two-family dwellings 3,500 square feet or greater require drawings prepared, **SIGNED AND SEALED** by a registered design professional.

Please review the following information prior to submittal. **Failure to include all required items will result in the application being rejected or Plan Review held up until all requirements are met.**

TYPICAL FLOOR PLAN

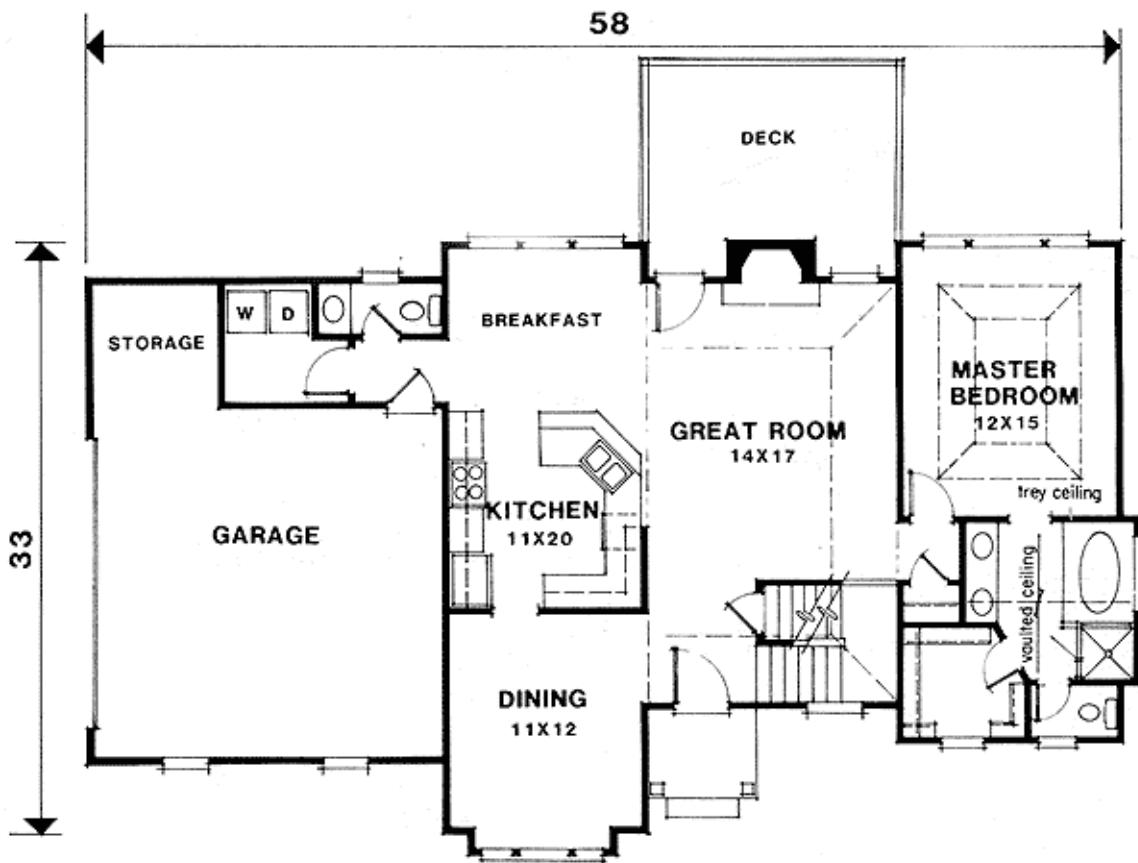

Provide a floor plan for each level of the house that you are remodeling / building.

Floor plan(s) should show the following information as a minimum:

- Name of project and its address.
- Scale of drawing (minimum 1/8" equals 1 foot)
- Date indicating when drawing was prepared.
- Name of person responsible for preparing the document.
- North arrow.
- General layout of the plan(s) (foundation, first floor, second floor and/or third floor)
- Placement of walls, doors, stairs, porches, columns posts, cabinetry bathroom fixtures, and any built-in elements, etc.
- Name of room(s) labeled (for example: Living Room, Bathroom, Bedroom, etc.)
- Dimensions (interior and exterior) indicating the relationship of building elements to one another as well as thickness of walls.
- Size and spacing of floor joists and rafters/trusses, as well as their orientation (direction of span)

TYPICAL EXTERIOR ELEVATION

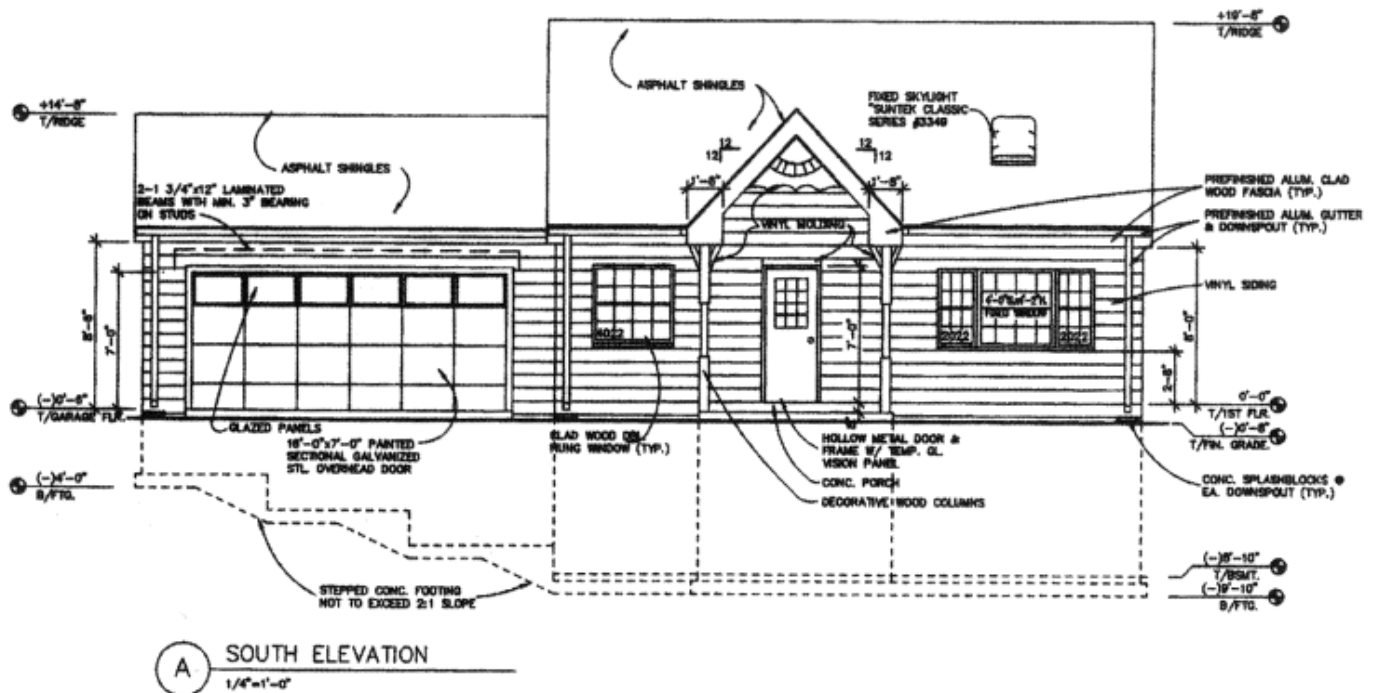

Exterior Building Elevation(s) should show the following information as a minimum:

- Name of project and its address.
- Scale of drawing.
- Date indicating when drawing was prepared.
- Name of person responsible for preparing document.
- Show all views of exterior of proposed building and/or addition in two-dimensional form indicating north, east, south and west views. Indicate all views affected by any proposed addition/renovation project.
- Indicate the type of finish materials visible on each elevation.
- Indicate roof slopes on all roofs.
- Indicate and label all window types with designation.
- Indicate, with a dimension, all roof overhangs at eave (gutter and rake (gable end) that differ from those indicated on the wall section(s).
- Show footing depths below the finished grade.
- Ridge vents (if chosen to vent the roof) should extend the full length of the ridge.

TYPICAL WALL SECTION

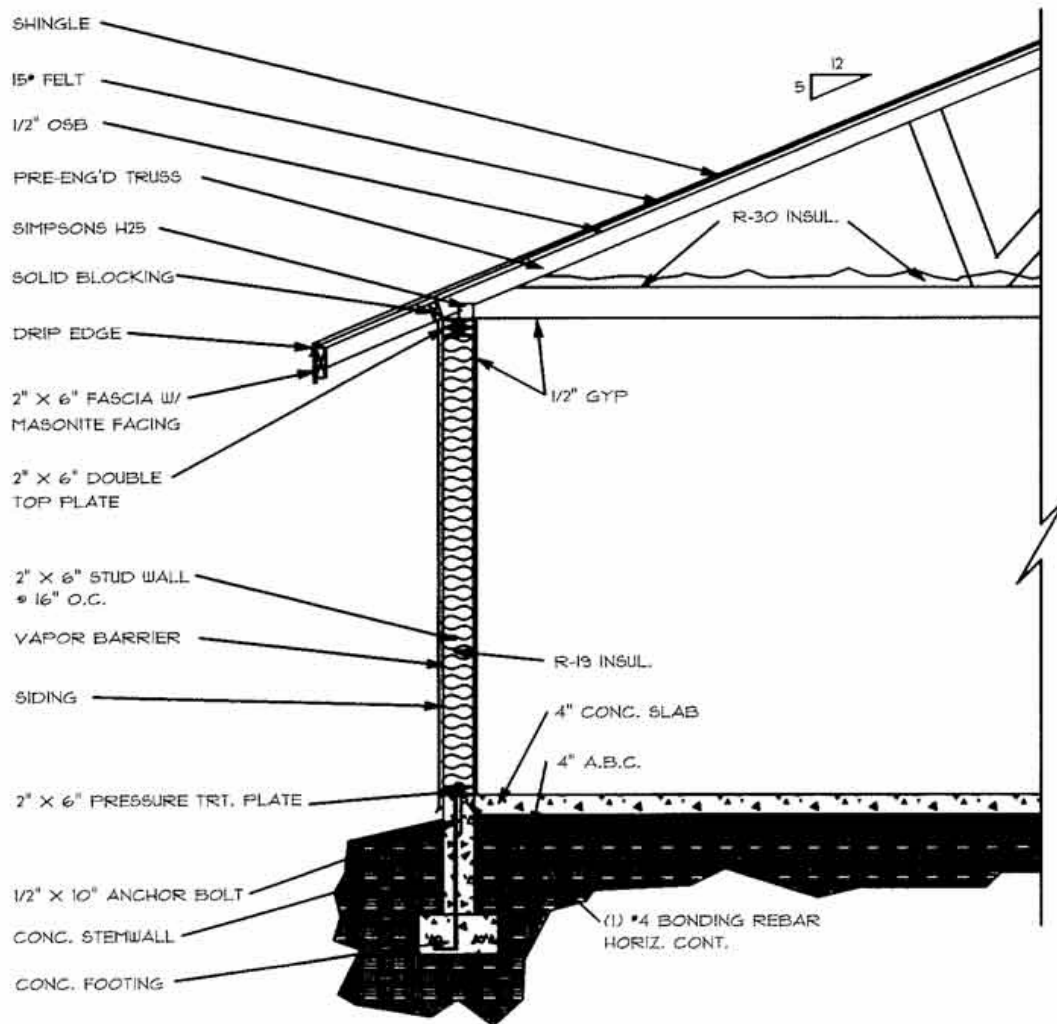

2" X 6" WALL SECTION

Wall section(s) should show the following information as a minimum:

- Name of project and its address.
- Scale of drawing.
- Date indicating when drawing was prepared.
- Name of person responsible for preparing document.

Roofing System

- Roofing (material, weight, etc.)
- Roll roofing or roofing felt.
- Sheathing (material and thickness indicated)
- Structural element(s) (rafters, trusses and/or ceiling joists with material, size and spacing indicated.
- Insulation and R-value indicated.
- Interior finish (material and thickness indicated)
- Soffit (material and type indicated)

Wall System (above ground)

- Exterior finish (material and thickness indicated.
- Wall wrap (material indicated)
- Sheathing (material and thickness indicated)
- Structural element (material, size and spacing indicated)
- Insulation (type and R- value rating indicated.
- Interior finish (material and thickness indicated)

Floor System(s)

- Sub-floor (material and thickness indicated)
- Underlayment (material and size indicated if required by floor finish selected)
- Joists (material, size and spacing indicated)
- Show how system connects to wall or roof systems.
- Insulation and R-value rating indicated at the rim joists.
- Ceiling on underside if applicable (material and thickness indicated)

Foundation System

- Footing drainage system.
- Footing (material and size indicated)
- Foundation wall (material and size indicated)
- Damproofing and/or waterproofing (material indicated)
- Anchor bolts (size and spacing indicated.
- Sill plate
- Basement slab (material, size and thickness indicated)
- Vapor barrier below slab (material and thickness indicated)
- Compacted fill below slabs (material and thickness indicated)
- Crawl space information (where applicable)