



CITY OF ANN ARBOR, MICHIGAN

Planning & Development Services

Revised November 18, 2009

SMOKE ALARMS

Michigan law requires smoke detectors in every home. Smoke alarms must be UL listed. They need to be installed in accordance with the provisions of the Michigan Residential Code, manufacturer's installation instructions, and the household fire warning equipment provisions of the National Fire Protection Act (NFPA) 72.

Since 1974, the code has required smoke detection and notification to alert occupants of potential problems. When asleep, the occupants of residential buildings will usually be unaware of a fire, and the fire will have an opportunity to spread before being detected. A majority of fire deaths occurring in residential buildings have occurred because of the delay in detection. It is for this reason that the code requires smoke alarms. The detection and notification system provides early warning to occupants of the building in the event of a fire, thereby providing a greater opportunity for everyone to evacuate.

Location

Smoke alarms shall be installed in the following locations:

- In each sleeping room.
- Outside each separate sleeping area in the immediate vicinity of the bedrooms.
- On each additional story of the dwelling, including basements but not including crawl spaces and uninhabitable attics. In dwellings or dwelling units with split levels and without an intervening door between the adjacent levels, a smoke alarm installed on the upper level shall suffice for the adjacent lower level provided that the lower level is less than one full story below the upper level.

When more than one smoke alarm is required to be installed within an individual dwelling unit, the alarm devices shall be interconnected in such a manner that the actuation of one alarm will activate all of the alarms in the individual unit. The interconnection is required so that no matter where the smoke first develops or is detected, occupants throughout the house will be made aware of the situation. The code requires that the alarm signal be "clearly audible" in the bedroom area. In new construction, the smoke detectors shall be hard wired to the buildings electrical system, and when this power is interrupted, shall receive power from a battery. Wiring shall be permanent and without a disconnecting switch other than those required for overcurrent protection.

Alterations, Repairs and Additions

When alterations, repairs or additions requiring a permit occur, or when one or more sleeping rooms are added or created in existing house, the individual dwelling unit shall be equipped with smoke alarms located as required for new houses; the smoke alarms shall be interconnected and hard wired.

There are two exceptions to these requirements:

1. Interconnection and hard-wiring of smoke alarms in existing areas shall not be required where the alterations or repairs do not result in the removal of interior wall or ceiling finishes exposing the structure, unless there is an attic, crawl space or basement available which could provide easy access for hard wiring and interconnection without the removal of interior finishes. In these cases, we will accept a wireless interconnected system. These systems require that one of the alarms be hard wired and the wireless signal is sent to the other alarms properly installed throughout the house. This system must be installed per manufacturer's instructions. If the wires can be fished through the walls with minimal disruption, we strongly suggest that the hard wired interconnected system be installed. We will, however, accept the wireless system if the installation of the hard-wired system presents a undue hardship. We suggest that you meet with the inspector on site at the beginning of the project to discuss any smoke alarm questions. Any further questions concerning which system should be used should be directed to the Building Official.
2. Work involving the exterior surfaces of dwellings, such as the replacement of roofing or siding, or the addition or replacement of windows or doors, or the addition of a porch or deck, are exempt from the requirements of this section. Work also involving the remodeling of kitchens or bathrooms without modifying the walls of the room is also exempt from the requirements of this section.

Smoke Alarm Locations in Existing Buildings Constructed before November 6, 1974

State of Michigan Public Act 64 of 2004 is designed to set a minimum standard for structures built prior to November 6, 1974, to protect the health, safety and welfare of the citizens of the state. These rules pertain to buildings constructed PRIOR to November 6, 1974. Construction of new structures or alteration of existing structures built after this date must follow the codes set forth for new construction.

Within each dwelling unit or sleeping unit constructed before November 7, 1974, a single-station smoke alarm shall be installed in the following locations:

- In each sleeping room or each area directly outside the sleeping room.
- On each floor level including the basement level.

For sleeping units with split levels and without an intervening door between the adjacent levels, a smoke alarm installed on the upper level shall suffice for the adjacent lower level provided that the lower level is less than 1 full story below the upper level.

Equipment Requirements

The required equipment for smoke alarms shall consist of the following:

1. Installation. Smoke alarm devices shall be listed and installed in accordance with the manufacturer's installation requirements, the provisions of the code and the provisions of NFPA 72.
2. Power Source: The equipment shall be hard wired and interconnected, operable power from the building wiring provided that such wiring is served from a commercial source and is equipped with a battery backup. Wiring shall be permanent and without a disconnecting switch other than as required for overcurrent protection.

A wireless, interconnected system is allowable in some alteration, repair and addition projects. It is required that the wireless system be powered by a non-rechargeable battery that is capable of operating the smoke alarm in a normal condition for a life of 5 years. We have found that the Kidde Model RF-SM-ACDC will accept a 5 year Lithium type battery which will meet these requirements and would suggest you use this model or its equivalent.

3. Audible Alarm Notification. The activation of the alarm signal shall produce a sound that is audible in all occupiable dwelling areas.
4. Testing and Maintenance. The owner of a dwelling unit, in which required or optional fire detection or fire protection systems equipment is installed, shall be responsible for the proper operation, testing, and maintenance of the equipment in accordance with the manufacturer's instructions included with the equipment. The occupant of rental dwelling units shall be responsible for the periodic operational testing and periodic cleaning of the installed equipment within the rental unit in accordance with the testing instructions provided in the manufacturer's instructions for the equipment. If the system fails, breaks, or is out of service, it shall be repaired and functional within 30 days. Smoke detectors should be checked monthly. Batteries should be replaced once a year. Alarms over 10 years old should be removed and replaced with new alarms.

Michigan Law Requires Smoke Detectors in Every Home!

- On every level
- In each sleeping room *
- Outside of each sleeping area
- Check your smoke detectors monthly
- Replace detectors over 10 years old

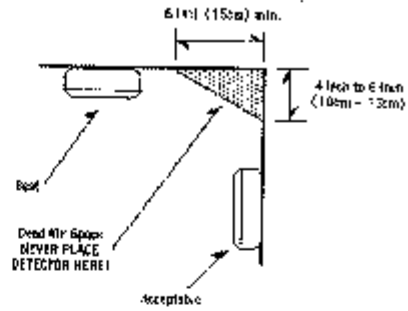

*bedroom detectors required for homes constructed after November 6, 1974

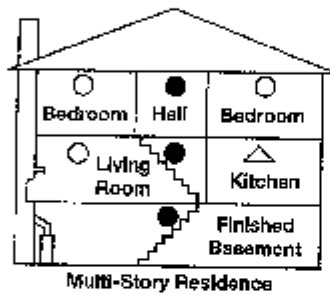

In Existing Homes

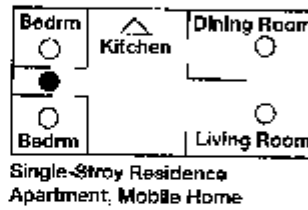

In New Construction or Major Remodeling

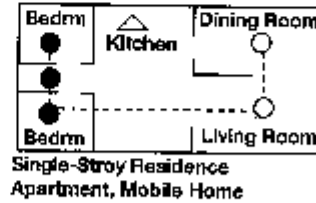

- Required locations ○ Recommended additional locations ▲ Photoelectric smoke detector only! (Optional)

--- Interconnection (wireless interconnection is a new technology for existing homes)

For more information visit the United States Fire Administration at:

http://www.usfa.dhs.gov/citizens/all_citizens/home_fire_pvc/alarms/